



Built in larder instruction manual

RiL1795



Contact Caple on 0117 938 7420 or for spare parts www.caple.co.uk





CONTENTS

Warnings	3
Safety warnings	6
Environmental protection	7
Old and out of order fridges	8
Installing and operation	8
Before using the fridge	9
Electrical connection	10
The parts of the appliance	11
Control panel	12
Settings	12
Temperature adjustment	14
Humidity controlled draw	15
Easy adjustable door balcony	15
Caple fresh (maxi fresh preserver)	16
Arranging food	16
Cleaning and maintenance	17
Defrosting	18
Replacing the LED strip	18
Transportation	19
Troubleshooting	20
Energy saving tips	21
Ventilation requirements	22
Technical product fiche	23
Caple contact details	24

Please keep this instruction manual for future reference





WARNING:

- Keep ventilation openings, in the appliance enclosure or in the built-in structure, clear of obstruction.
- Do not use mechanical devices or other means to accelerate the defrosting process, other than those recommended by the manufacturer.
- Do not use electrical appliances inside the food storage compartments of the appliance, unless they are of the type recommended by the manufacturer.
- Do not damage the refrigerant circuit.
- To avoid a hazard due to the instability of the appliance, it must be fixed in accordance with the instructions.

WARNING:

- If your appliance uses R600a as a refrigerant – you can learn this information from the rating label on the cooler- you should be careful during transport to prevent your appliance's cooler elements from being damaged. Although R600a is an environmental friendly and natural gas, as it is explosive, in case of a leakage to be occurred due to a damage in the cooler elements move your fridge from open flames or heat sources and ventilate the room where the appliance is located for a few minutes.

Please keep this instruction manual for future reference



- While carrying and positioning the fridge, do not damage the cooler gas circuit.
- Do not store explosive substances such as aerosol cans with a flammable propellant in this appliance.
- This product is not designed for commercial use, it is a household appliance only. It is not intended to be used in:
 - Staff kitchen areas in shops, offices and other working environments.
 - Bed and breakfast type environments.
 - By clients in hotels, motels and other residential type environments.
- If the socket does not match the refrigerator plug, it must be replaced by a Caple approved engineer or similar qualified persons in order to avoid a hazard.
- This appliance is not intended for use by persons (including children) with reduced physical, sensory or mental capabilities, or lack of experience and knowledge, unless they have been given supervision or instruction concerning use of the appliance by a person responsible for their safety. Children should be supervised to ensure that they do not play with the appliance.
- A specially grounded plug has been connected to the power cable of your refrigerator. This plug should be used with a specially grounded socket of 13 amperes. If there

Please keep this instruction manual for future reference





is no such socket in your house, please have it installed by an authorised electrician.

- This appliance can be used by children aged from 8 years and above and persons with reduced physical, sensory or mental capabilities or lack of experience and knowledge if they have been given supervision or instruction concerning use of the appliance in a safe way and understand the hazard involved.
- Children shall not play with the appliance.
- Cleaning and user maintenance, shall not be made by children without supervision.
- If the supply cord is damaged, it must be replaced by a Caple approved engineer or similar qualified persons in order to avoid a hazard.
- This appliance is not intended for use at altitudes exceeding 2000m
- When positioning the appliance, ensure the supply cord is not trapped or damaged.
- Do not locate multiple portable socket-outlets or portable power supplies at the rear of the appliance.
- Do not use plug adapter.



Symbol ISO 7010 W021

Warning; Risk of fire / flammable materials

Please keep this instruction manual for future reference

Instruction manual RiL1795 5





SAFETY WARNINGS

- Do not use multiple sockets or an extension cord.
- Do not plug in damaged, torn or old plugs.
- Do not pull, bend or damage the cord.
- In case your supply cord is damaged, it should be replaced by Cable service in order to avoid any danger.
- This appliance is designed for use by adults, do not allow children to play with the appliance or let them hang on the door.
- Do not break or scrape ice with sharp objects like a knife or similar.
- Do not plug-in or pull out the plug from the receptacle with wet hands to prevent electrocution!
- Do not place explosive or flammable material in your fridge for your safety. Place drinks with higher alcohol amount vertically and by closing their necks tightly in the fridge department.
- Fix the accessories in the fridge during transportation to prevent damage to accessories

Please keep this instruction manual for future reference





ENVIRONMENTAL PROTECTION

Waste electrical products should not be disposed of with household waste. Please recycle where facilities exist. Check with your Local Authority or retailer for recycling advice. This appliance is marked according to the European directive 2002/96/EC on Waste Electrical and Electronic Equipment (WEEE).

By ensuring this product is disposed of correctly, you will help prevent potential negative consequences for the environment and human health, which could otherwise be caused by inappropriate waste handling of this product. The symbol on the product indicates that this product may not be treated as household waste. Instead it shall be handed over to the applicable collection point for the recycling of electrical and electronic equipment. Disposal must be carried out in accordance with local environmental regulations for waste disposal.

For more detailed information about treatment, recovery and recycling of this product, please contact your local council, your household waste disposal service or the retailer where you purchased the product.

CE DECLARATIONS OF CONFORMITY **CE**

This appliance has been manufactured to the strictest standards and complies with all applicable legislation, Low Voltage Directive (LVD) and Electromagnetic Compatibility (EMC).

Please keep this instruction manual for future reference

Instruction manual RiL1795 7



OLD AND OUT-OF-ORDER FRIDGES

- If your old fridge has a lock, break or remove the lock before discarding it, because children may get trapped inside it and may cause an accident.
- Old fridges and freezers contain insulation material and refrigerant with CFC. Therefore, take care not to harm the environment when you are discarding your old fridges.

NOTE:

- Please read the instruction manual carefully before installing and using your appliance. Caple cannot be held responsible for damage occurred due to misuse.
- Follow all instructions on your appliance and instruction manual, and keep this manual in a safe place to resolve the problems that may occur in the future.
- This appliance is produced for domestic use only and it can only be used in house and for the specified purposes. It is not suitable for commercial or common use. Such use will cause the guarantee of the appliance to be canceled and Caple will not be responsible for the losses to be occurred.

INSTALLING AND OPERATING YOUR FRIDGE

Before starting to use your fridge, you should pay attention to the following points:

- Operating voltage for your fridge is 220-240V at 50Hz.
- We do not take the responsibility of the damages that occur due to ungrounded usage.
- Place your fridge in a place where it would not be exposed to direct sunlight.
- Your appliance should be at least 50cm away from hobs, Gas ovens and heater cores, and should be at least 5cm away from electrical ovens.
- Your fridge should never be used outdoors or left under the rain.
- When your fridge is placed next to a deep freezer, there should be at least 2 cm between them to prevent humidity on the outer surface.
- Do not place heavy items on the appliance.
- Do not place anything on your fridge, and install your fridge in a suitable place so that at least 15cm is available on the upper side.

Please keep this instruction manual for future reference



- The adjustable front legs should be stabilized at an appropriate height to allow your fridge to operate in a stable and proper way. You can adjust the legs by turning them clockwise (or in the opposite direction). This should be done before placing food in the fridge.
- Before using your fridge, wipe all parts with warm water added with a tea spoonful of sodium bicarbonate, and then rinse with clean water and dry. Replace all parts after cleaning.
- Install the distance adjustment plastic (the part with black vanes at the rear) by turning it 90° as shown in the figure to prevent the condenser from touching the wall.
- The refrigerator should be placed against a wall with a free distance not exceeding 75mm.

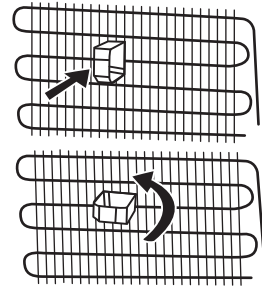

BEFORE USING YOUR FRIDGE

- When it is operated for the first time or after transportation, keep your fridge in the upright position for 12 hours before plugging in to allow efficient operation. Otherwise, you may damage the compressor.
- Your fridge may have a smell when it is operated for the first time; the smell will fade away when your fridge starts to cool.

Please keep this instruction manual for future reference



ELECTRICAL CONNECTION

For your safety please read the following information

WARNING: THIS APPLIANCE MUST BE EARTHED.

This appliance operates from 220-240 volts and should be protected by a 13 amp fuse in the plug.

The appliance is supplied with a standard 13 amp 3-pin mains plug fitted with a 13-amp fuse. Should the fuse require replacement, it must be replaced with a fuse rated at 13 amp and approved to BS1362.

If the mains plug which is fitted is unsuitable for the socket outlet in your home or is removed for any other reason, please follow the instructions below on how to wire a 13 amp 3 pin plug.

HOW TO WIRE A 13 AMP PLUG.

IMPORTANT

The wires in the mains lead on this appliance are coloured in accordance with the following code:

Green and Yellow - Earth

Blue – Neutral

Brown – Live

As the colours may not correspond with the markings identifying the terminals in your plug proceed as follows.

The green and yellow wire must be connected to the terminal in the plug which is marked with the letter E or with the earth symbol  or coloured green and yellow.

The blue wire must be connected to the terminal marked N.

The brown wire must be connected to the terminal marked L.

You must make sure the lead is firmly secured under the cord clamp.

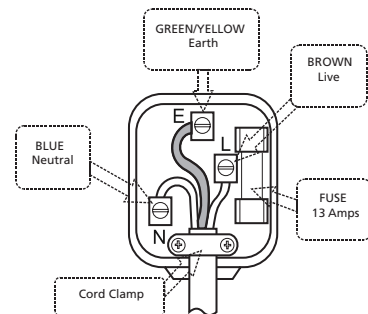

Please keep this instruction manual for future reference





THE PARTS OF THE APPLIANCE AND THE COMPARTMENTS

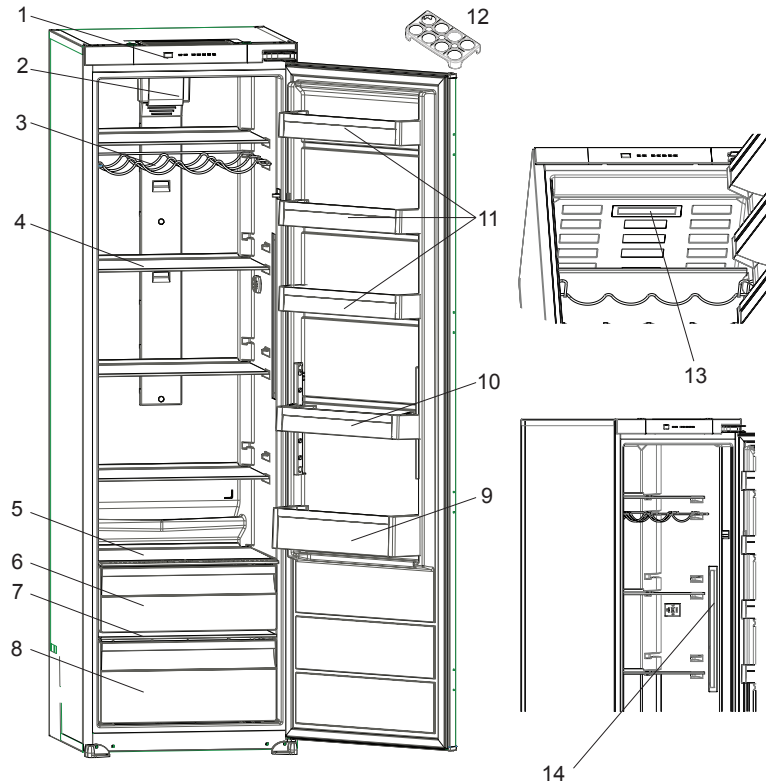

- | | | |
|---------------------|---------------------------------------|---------------------------------|
| 1. Control panel | 6. Humidity controlled vegetable draw | 11. Door balcony |
| 2. Turbo fan | 7. Bottom draw cover | 12. Egg holder |
| 3. Wine rack | 8. Bottom draw | 13. Upper side LED strip |
| 4. Fridge shelves | 9. Bottle shelf | 14. Left / Right side LED strip |
| 5. Upper draw cover | 10. Easy adjustable door balcony | |

This presentation is only for information about the parts of the appliance. Parts may vary according to the appliance model.

Please keep this instruction manual for future reference





CONTROL PANEL

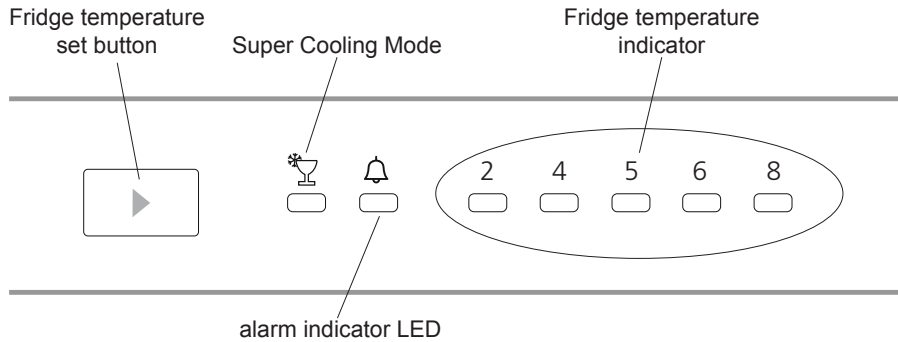

FRIDGE TEMPERATURE SETTING BUTTON

This button allows you to change and set the temperature of the fridge. In order to set the temperature values of the fridge, press this button. Use this button also to activate Super Cooling mode.

ALARM LIGHT

In case of a problem within the fridge or the door is left open the alarm LED will illuminate red.

SUPER COOLING MODE

When would it be used?

- To cool huge quantities of food.
- To cool fresh food.
- To cool food quickly.
- To store seasonal food for a long time.

Please keep this instruction manual for future reference



How to use?

- Press the temperature set button until super cooling light comes on.
- Super cooling LED will light during this mode.
- For optimal appliance performance in maximum cooling capacity, set the appliance to active Super Cooling mode 6 hours before you put the fresh food into the fridge.

During this mode:

If you press temperature set button, the mode will be cancelled and the setting will be restored from 2°C.

NOTE:

“Super cooling” mode will be automatically cancelled after 6 hours or when cooling sensor temperature drops beneath 2 °C.

FRIDGE TEMPERATURE SETTINGS

- The initial temperature of the Setting Display is 5°C.
- Press fridge setting button once.
- Every time you press the button, the setting temperature will increase. (2°C, 4°C, 5°C, 6°C, 8°C, super cooling)
- If you press the fridge setting button until super cooling symbol is displayed and you do not press any button within the following 3 seconds, Super cooling LED will blink and then be set.
- If you keep on pressing, it will restart from last value..

Please keep this instruction manual for future reference

Instruction manual RiL1795 13



WARNINGS ABOUT TEMPERATURE ADJUSTMENTS

- Your temperature adjustments will not be deleted when an energy breakdown occurs.
- Temperature adjustments should be made according to the frequency of door openings, the quantity of food kept inside the fridge and ambient temperature of the place of your fridge.
- Your fridge should be operated up to 24 hours according to the ambient temperature without interruption after being plugged in to be completely cooled.
- Do not open doors of your fridge frequently and do not place much food inside it during this period.
- A 5 minute delaying function is applied to prevent damage to the compressor of your fridge, when you take the plug off and then plug it on again to operate it or when an energy breakdown occurs. Your fridge will start to operate normally after 5 minutes.
- Your fridge is designed to operate in the ambient temperature intervals stated in the standards, according to the climate class stated in the information label. We do not recommend operating your fridge out of stated temperatures value limits in terms of cooling effectiveness.
- This appliance is designed for use at an ambient temperature within the 10°C - 38°C range.

CLIMATE CLASS	AMBIENT TEMPERATURE °C
T	Between 16 and 43 (°C)
ST	Between 16 and 38 (°C)
N	Between 16 and 32 (°C)
SN	Between 10 and 32 (°C)

Please keep this instruction manual for future reference





HUMIDITY CONTROLLED DRAW

When the humidity controller is in the closed position, it allows fresh fruit and vegetables to be stored longer.

When the draw is totally full, the humidity controller should be opened. By means of this the air in the draw and humidity rate will be controlled and endurance life will be increased. If you see any condensation on the glass shelf above, the humidity control should be moved into the open position..

NOTE:

These draws are specifically designed to store fruit & vegetables only. We do not recommend storing meats and/or fish in these draws.

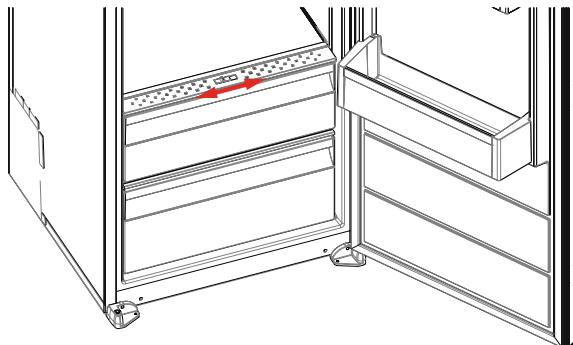

EASY ADJUSTABLE DOOR BALCONY

Your fridge comes included with 1 adjustable door balcony (along with the other normal door balconies). To adjust this door balcony to the appropriate height, hold the bottom of the balcony and pull on the button on each end to unlock as shown in Fig.1. Whilst pulled down move the door balcony to the appropriate height (there are 6 height positions). Once set at the correct height, release the buttons to lock it into position.

NOTE:

Please ensure the balcony is empty before adjusting.

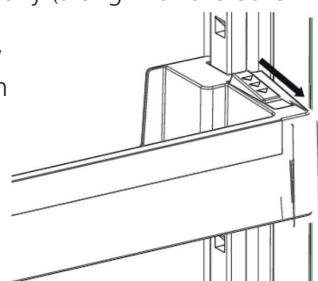

Please keep this instruction manual for future reference





CAPLE FRESH (MAXI-FRESH PRESERVER)

Caple Fresh technology eliminates the ethylene gas (a by product of fresh foods) inside the vegetable draw. By this method, it maximizes the fresh foods shelf life, especially green vegetables. Caple Fresh also blocks the bad smells produced in the refrigerator.

- The Caple Fresh filter must be cleaned once a year. It can be cleaned by leaving in sunlight for one day.
- When you want to clean the filter, remove the back side in the direction of the arrow.
- Don't wet this part with water or detergent.

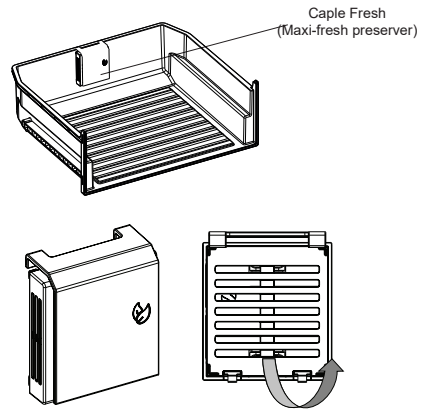

ARRANGING FOOD IN THE APPLIANCE

- To reduce humidity and consequent increase of frost never place liquids in unsealed containers in the refrigerator. Frost tends to concentrate in the coldest parts of the evaporator and in time will require more frequent defrosting.
- Never place warm food in the refrigerator. Warm food should be allowed to cool at room temperature and should be arranged to ensure adequate air circulation in the refrigerator.
- Nothing should touch the back wall as it will cause frost and the packages can stick on the back wall.
- Do not open the refrigerator door too frequently.
- Arrange the meat and fish (wrapped in packages or sheets of plastic) which will be used within 1-2 days, towards the bottom section of the refrigerator (that is above the crisper) as this is the coldest section and will ensure the best storing conditions.
- **NOTE:** Do not store Meat or fish in the lower draws as this could spoil them quickly. These draws are specifically designed for fruit and vegetables only.
- You can put the fruits and vegetables into the lower draws without packing.

Please keep this instruction manual for future reference





CLEANING AND MAINTENANCE

Make sure to unplug the fridge before starting to clean it.

- Do not clean the appliance by pouring water onto it.
- Make sure that no water enters the lamp housing and other electrical components.
- The refrigerator should be cleaned periodically using a solution of bicarbonate of soda and lukewarm water.
- Clean the accessories separately with soap and water.
Do not clean them in the dishwasher.
- Do not use abrasive products, detergents or soaps. After washing, rinse with clean water and dry carefully. When you have finished cleaning, reconnect the plug to the mains supply with dry hands.
- Clean the condenser with a broom at least twice a year. This will help you to save on energy costs and increase productivity

THE POWER SUPPLY MUST BE DISCONNECTED

Please keep this instruction manual for future reference

Instruction manual RiL1795 17



DEFROSTING

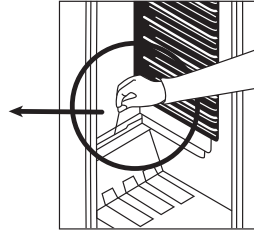
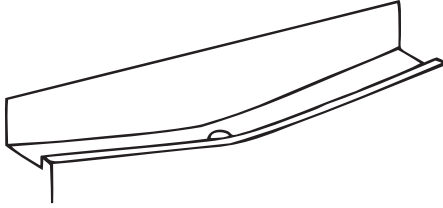

- Defrosting occurs automatically in the refrigerator compartment during operation; the water is collected by the evaporation tray and evaporates automatically.
- The evaporation tray and the water drain hole should be cleaned periodically with the defrost drain plug to prevent the water from collecting at the bottom of the refrigerator instead of flowing out.
- You can also clean the drain hole by pouring ½ glass of water down it

REPLACING THE LED STRIP

LED lights should be changed by authorised personnel only. please contact an electrician, or Caple service for assistance - 0117 938 7420.

TRANSPORTATION AND REPOSITIONING

- The original packages and foamed polystyrene (PS) can be retained if required.
- During transportation, the appliance should be secured with a wide string or a strong rope. The instructions written on the corrugated box must be followed while transporting.
- Before transporting or changing the installation position, all the moving objects (ie, shelves, draws...) should be taken out or fixed with bands in order to prevent them from getting damaged.
- Carry your fridge in the upright position.

Please keep this instruction manual for future reference





TROUBLESHOOTING

ALARM INDICATOR LED IS TURNING ON	ERROR TYPE	WHY	WHAT TO DO
	"Failure Warning"	There is/are some part(s) Out of order or there is a failure in cooling process	Check if the door is open or not. If the door is not open, call Caple service for assistance as soon as possible

If your fridge is not working properly, it may be a minor problem, therefore check the following, before calling an electrician to save time and money.

WHAT TO DO IF YOUR APPLIANCE DOES NOT OPERATE;

Check that;

- There is no power.
- The general switch in your home is disconnected.
- The socket is not sufficient. To check this, plug in another appliance that you know which is working into the same socket.

WHAT TO DO IF YOUR APPLIANCE PERFORMS POORLY;

Check that;

- You have not overloaded the appliance.
- The fridge temperature is set to 2C.
- The door is closed perfectly.
- There is no dust on the condenser.
- There is enough space at the rear and side walls.

IF YOUR FRIDGE IS OPERATING TOO LOUDLY;

Normal Noises

Cracking (Ice cracking) Noise:

- During automatic defrosting.
- When the appliance is cooled or warmed (due to expansion of appliance material).

Short cracking: Heard when the thermostat switches the compressor on/ off.

Please keep this instruction manual for future reference



Compressor noise: Normal motor noise. This noise means that the compressor is operating normally. The compressor may cause more noise for a short time when it is activated.

Bubbling noise: This noise is caused by the flow of the refrigerant in the tubes of the system.

Water flow noise: Normal flow noise of water flowing to the evaporation container during defrosting. This noise can be heard during defrosting.

Air blowing / Fan noise: Normal fan noise. This noise can be heard during normal operation of the system due to the circulation of air.

If the edges of fridge cabinet that the door joint contact are warm; Especially in summer (hot weather), the surfaces that the joint contact may get warmer during the operation of the compressor, this is normal.

If humidity builds up inside the fridge;

- Are all food packed properly? Are the containers dried before placing them in the fridge?
- Is the fridge door opened frequently? Humidity of the room gets in the fridge when the doors are opened. Humidity build up will be faster when you open the doors more frequently, especially if the humidity of the room is high.

If the door is not opened and closed properly;

- Do the food packages prevent closing of the door?
- Are the door compartments, shelves and drawers placed properly?
- Are door seals / joints broken or torn?
- Is your fridge on a level surface?

Recommendations

To stop the appliance completely, unplug from main socket (for cleaning and when the door is left open)

Please keep this instruction manual for future reference





ENERGY SAVING TIPS

1. Install the appliance in a cool, well ventilated room, but not in direct sunlight and not near a heat source (radiator, cooker.. etc). Otherwise use an insulating plate.
2. Allow warm food and drinks to cool down outside the appliance.
3. Cover drinks or other liquids when placing them in the appliance otherwise humidity increases in the appliance. Therefore, the working time gets longer. Also covering drinks and other liquids helps to preserve smell and taste.
4. Try to avoid keeping the doors open for long periods or opening the doors too frequently as warm air will enter the cabinet and cause the compressor to switch on unnecessarily often.
5. Keep the covers of the different temperature compartments (crisper, chiller ...etc) closed.
6. Door gasket must be clean and pliable. Replace gaskets if worn.

Please keep this instruction manual for future reference

Instruction manual RiL1795 21





VENTILATION REQUIREMENTS

The main consideration when installing a refrigeration product into a cabinet is ventilation. The heat removed from the appliance needs to be dissipated into the room. Failure to correctly ventilate the product can result in increased running costs and premature failure. It will also invalidate the guarantee provided with the appliance.

An air intake in the plinth is required to allow for the correct air flow (recommended 500mm x 75mm). If preferred a decorative stainless steel plinth grille is available, product code: GRILL/SENSE600. This can be purchased from your retailer or www.caple.co.uk.

To ensure the correct operation of the appliance it is important the top of the housing is not blocked off. The top of the cabinet needs to be vented into the room, the recommended minimum size of the vent opening is 500x75mm.

There should also be space at the rear of the cabinet to allow the cool air to be drawn over the condenser. This should also be at least 500mm x 75mm. The more air available to circulate the product, the more efficiently it will operate

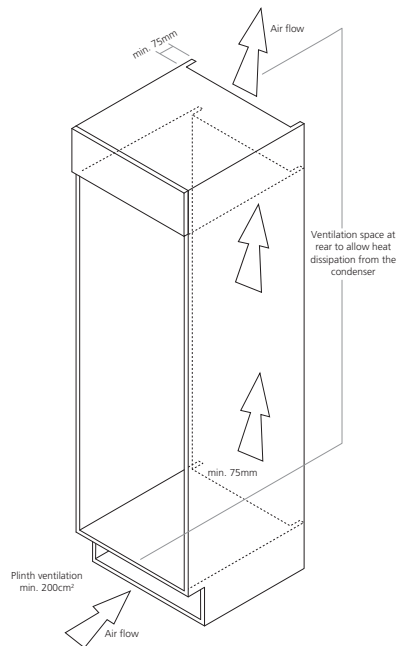

Please keep this instruction manual for future reference





TECHNICAL FICHE

PRODUCT FICHE	
Brand	CAPLE
Model	RIL1795
Product category	1 (Refrigerator)
Energy class	A++
Annual energy consumption*	111 kWh
Total gross	303 l
Total net volume	300 l
Refrigerator gross volume	303 l
Refrigerator net volume	300 l
Chiller compartment net volume	
Freezer gross volume	
Freezer net volume	
Star rating	
Refrigeration system	Static
Temperature rise time (-18°C/-9°C)	
Freezing capacity	
Climate class **	ST/SN (10°C - 38°C)
Noise emission	40 dB(A)

* Energy consumption of 111 kWh per year, calculated on the basis of results obtained in 24 hours under normalised test conditions. Real energy consumption depends on the conditions in which the equipment is used as well as where it is placed.

**This appliance is designed for use at an ambient temperature within the 10°C - 38°C range.

Please keep this instruction manual for future reference

Instruction manual RiL1795 23





Caple Service
Fourth Way
Avonmouth
Bristol
BS11 8DW

t: 0117 938 7420
e: service@caple.co.uk
www.caple.co.uk

Please keep this instruction manual for future reference

