



# Built in freezer instruction manual

## RiF1795



Contact Caple on 0117 938 7420 or for spare parts [www.caple.co.uk](http://www.caple.co.uk)





## CONTENTS

Warnings	3
Safety warnings	6
Environmental protection	7
Old and out of order freezers	8
Installing and operation	8
Before using the freezer	9
Frost free technology	10
The parts of the appliance	11
Control panel	12
Settings	12
Temperature adjustment	14
Arranging food	16
Cleaning and maintenance	18
Defrosting	18
Replacing the LED strip	18
Transportation	19
Troubleshooting	20
Energy saving tips	22
Ventilation requirements	23
Technical product fiche	24
Caple contact details	28

Please keep this instruction manual for future reference





## **WARNING:**

- Keep ventilation openings, in the appliance enclosure or in the built-in structure, clear of obstruction.
- Do not use mechanical devices or other means to accelerate the defrosting process, other than those recommended by the manufacturer.
- Do not use electrical appliances inside the food storage compartments of the appliance, unless they are of the type recommended by the manufacturer.
- Do not damage the refrigerant circuit.
- To avoid a hazard due to the instability of the appliance, it must be fixed in accordance with the instructions.

## **WARNING:**

- If your appliance uses R600a as a refrigerant – you can learn this information from the rating label on the cooler- you should be careful during transport to prevent your appliance's cooler elements from being damaged. Although R600a is an environmental friendly and natural gas, as it is explosive, in case of a leakage to be occurred due to a damage in the cooler elements move your freezer from open flames or heat sources and ventilate the room where the appliance is located for a few minutes.

Please keep this instruction manual for future reference



- While carrying and positioning the freezer, do not damage the cooler gas circuit.
- Do not store explosive substances such as aerosol cans with a flammable propellant in this appliance.
- This product is not designed for commercial use, it is a household appliance only. It is not intended to be used in:
  - Staff kitchen areas in shops, offices and other working environments.
  - Bed and breakfast type environments.
  - By clients in hotels, motels and other residential type environments.
- If the socket does not match the freezer plug, it must be replaced by a Caple approved engineer or similar qualified persons in order to avoid a hazard.
- This appliance is not intended for use by persons (including children) with reduced physical, sensory or mental capabilities, or lack of experience and knowledge, unless they have been given supervision or instruction concerning use of the appliance by a person responsible for their safety. Children should be supervised to ensure that they do not play with the appliance.
- A specially grounded plug has been connected to the power cable of your freezer. This plug should be used with a specially grounded socket of 13 amperes. If there

Please keep this instruction manual for future reference





is no such socket in your house, please have it installed by an authorised electrician.

- This appliance can be used by children aged from 8 years and above and persons with reduced physical, sensory or mental capabilities or lack of experience and knowledge if they have been given supervision or instruction concerning use of the appliance in a safe way and understand the hazard involved.
- Children shall not play with the appliance.
- Cleaning and user maintenance, shall not be made by children without supervision.
- If the supply cord is damaged, it must be replaced by a Caple approved engineer or similar qualified persons in order to avoid a hazard.
- This appliance is not intended for use at altitudes exceeding 2000m
- When positioning the appliance, ensure the supply cord is not trapped or damaged.
- Do not locate multiple portable socket-outlets or portable power supplies at the rear of the appliance.
- Do not use plug adapter.



Symbol ISO 7010 W021

Warning; Risk of fire / flammable materials

Please keep this instruction manual for future reference

Instruction manual RiF1795 5





## SAFETY WARNINGS

- Do not use multiple sockets or an extension cord.
- Do not plug in damaged, torn or old plugs.
- Do not pull, bend or damage the cord.
- This appliance is designed for use by adults, do not allow children to play with the appliance or hang on the door.
- Do not plug-in or pull out the plug from the socket with wet hands to prevent electrocution!
- Do not place glass bottles or beverage cans in the freezer. Bottles or cans may explode.
- Do not place explosive or flammable material in your freezer for your safety.
- When taking out ice made in the freezer, do not touch it with bare hands. Ice may cause ice burns and/or cuts.
- Do not touch frozen goods with wet hands! Do not eat ice-cream and ice cubes immediately after you have taken them out of the freezer!
- Do not re-freeze frozen goods after they have melted. This may cause health issues like food poisoning.
- Do not cover the body or top of freezer with lace. This affects the performance of your freezer.
- Fix the accessories in the freezer during transportation to prevent damage to accessories.

Please keep this instruction manual for future reference



## ENVIRONMENTAL PROTECTION

Waste electrical products should not be disposed of with household waste. Please recycle where facilities exist. Check with your Local Authority or retailer for recycling advice. This appliance is marked according to the European directive on Waste Electrical and Electronic Equipment (WEEE).

By ensuring this product is disposed of correctly, you will help prevent potential negative consequences for the environment and human health, which could otherwise be caused by inappropriate waste handling of this product. The symbol on the product indicates that this product may not be treated as household waste. Instead it shall be handed over to the applicable collection point for the recycling of electrical and electronic equipment. Disposal must be carried out in accordance with local environmental regulations for waste disposal.

For more detailed information about treatment, recovery and recycling of this product, please contact your local council, your household waste disposal service or the retailer where you purchased the product.

## CE DECLARATIONS OF CONFORMITY **CE**

This appliance has been manufactured to the strictest standards and complies with all applicable legislation, Low Voltage Directive (LVD) and Electromagnetic Compatibility (EMC).

Please keep this instruction manual for future reference

Instruction manual RiF1795 7



## OLD AND OUT-OF-ORDER FREEZERS

- If your old fridge/freezer has a lock, break or remove the lock before discarding it, because children may get trapped inside it and may cause an accident.
- Old fridges and freezers contain insulation material and refrigerant with CFC. Therefore, take care not to harm the environment when you are discarding your old fridge/freezer.

### NOTE:

- Please read the instruction manual carefully before installing and using your appliance. Caple cannot be held responsible for damage occurred due to misuse.
- Follow all instructions on your appliance and instruction manual, and keep this manual in a safe place to resolve the problems that may occur in the future.
- This appliance is produced for domestic use only and it can only be used in house and for the specified purposes. It is not suitable for commercial or common use. Such use will cause the guarantee of the appliance to be canceled and Caple will not be responsible for the losses to be occurred.

## INSTALLING AND OPERATING YOUR FREEZER

Before starting to use your freezer, you should pay attention to the following points:

- The operating voltage for your freezer is 220-240 V at 50Hz.
- The plug must be accessible after installation.
- Your freezer may have a smell when it is operated for the first time. This is normal and the smell will fade away when your freezer starts to cool.
- Before connecting your freezer, ensure that the information on the Rating label (voltage and connected load) matches that of the mains electricity supply. If in doubt, consult a qualified electrician.
- Insert the plug into a socket with an efficient ground connection. If the socket has no ground contact or the plug does not match, we recommend that you consult a qualified electrician for assistance.
- The appliance must be connected with a properly installed fused socket. Power supply (AC) and voltage at the operating point must match with the details on the Rating label of the appliance (Rating label is located on the inside left of the appliance).

Please keep this instruction manual for future reference



- We do not accept responsibility for any damages that occur due to ungrounded usage.
- Place your freezer where it will not be exposed to direct sunlight.
- Your freezer should never be used outdoors or exposed to rain.
- Your appliance should be at least 50 cm away from gas hobs, ovens and heater cores, and at least 5 cm away from electrical ovens.
- When your freezer is placed next to a deep freezer, there should be at least 2 cm between them to prevent humidity forming on the outer surface.
- Do not place heavy items on the appliance.
- Clean the appliance thoroughly, especially the interior, before use (see Cleaning and Maintenance).
- The installation procedure into the kitchen unit is given in the Installation Manual. This product is intended to be used in proper kitchen units only.
- Use the adjustable front legs to make sure your appliance is level and stable. You can adjust the legs by turning them in either direction. This should be done before placing food in the freezer.
- Before using your freezer, wipe all parts with a solution of warm water and a teaspoon of sodium bicarbonate, then rinse with clean water and dry. Place all parts in the freezer after cleaning.
- Install the plastic distance guide (the part with black vanes at the rear) by turning it 90° (as shown in the figure) to prevent the condenser from touching the wall.
- The freezer should be placed against a wall with a free space not exceeding 75 mm.

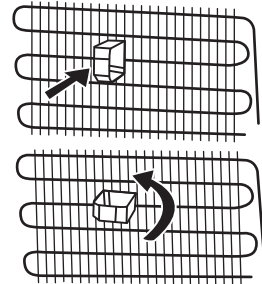

## BEFORE USING YOUR FREEZER

- When using your freezer for the first time, or after transportation, keep it in an upright position for at least 12 hours before plugging into the mains. This allows efficient operation and prevents damage to the compressor.
- Your freezer may have a smell when it is operated for the first time. This is normal and the smell will fade away when your freezer starts to cool.

Please keep this instruction manual for future reference





## INFORMATION ON FROST FREE TECHNOLOGY

Frost free freezers differ from other static freezers in their operating principle.

In normal freezers, the humidity entering the freezer due to opening the door and the humidity inherent in the food causes freezing in the freezer compartment. To defrost the frost and ice in the freezer compartment, you are periodically required to turn off the freezer, place the food that needs to be kept frozen in a separately cooled container and remove the ice gathered in the freezer compartment manually.

The situation is completely different in frost free freezers. Dry and cold air is blown into the fridge and freezer compartments homogeneously and evenly from several points via a blower fan. Cold air dispersed homogeneously and evenly between the shelves cools all of your food equally and uniformly, thus preventing humidity and freezing.

Therefore your frost free freezer allows you ease of use, in addition to its huge capacity and stylish appearance.

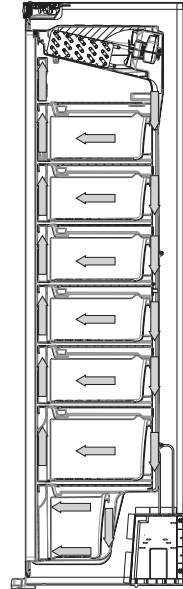

Please keep this instruction manual for future reference



## THE PARTS OF THE APPLIANCE AND THE COMPARTMENTS USAGE INFORMATION

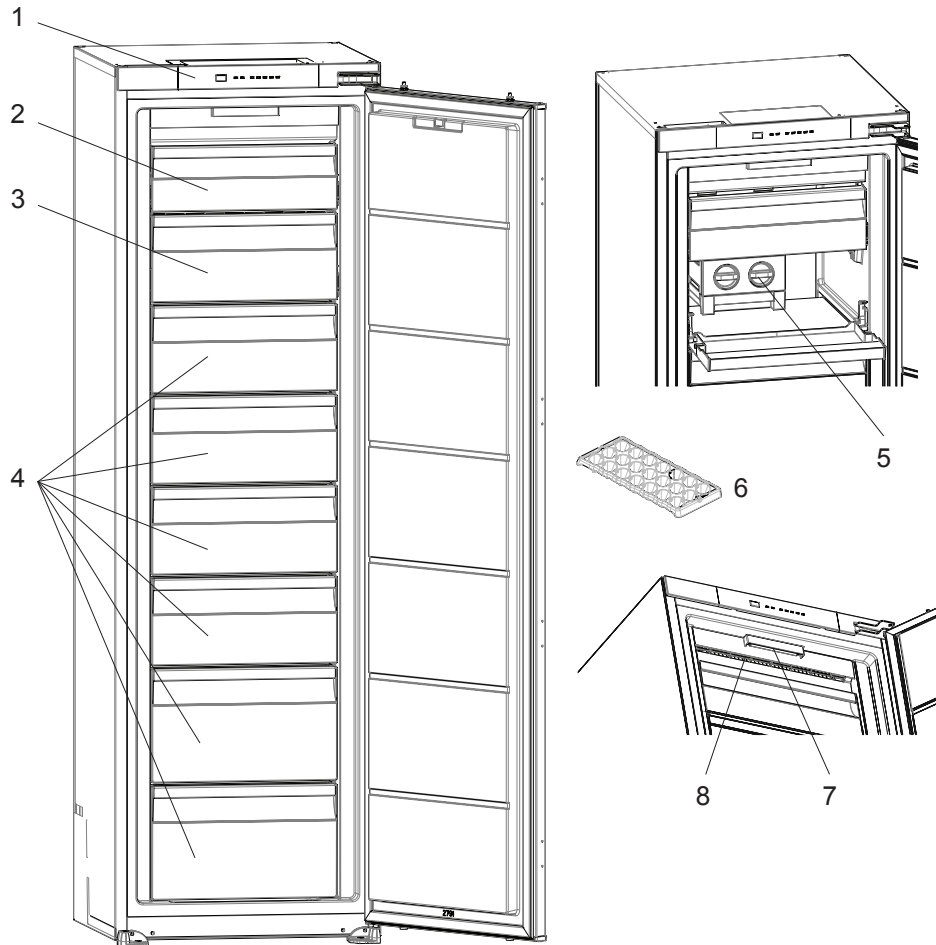

- |   |                                      |
|---|--------------------------------------|
| 1. Control panel                                    | 5. Ice maker                         |
| 2. Freezer upper room cover                         | 6. Ice tray                          |
| 3. Freezer compartment drawers / freezer room cover | 7. Freezer LED strip                 |
| 4. Freezer compartment drawers                      | 8. Frost free air circulation system |

Please keep this instruction manual for future reference





## CONTROL PANEL

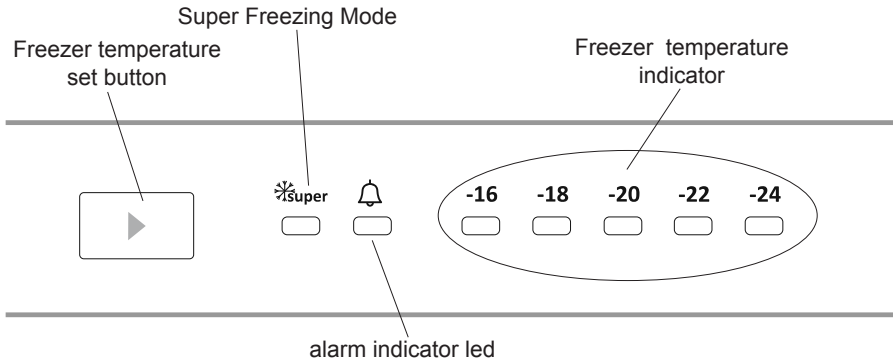

### FREEZER TEMPERATURE SETTING BUTTON

This button allows setting temperature of the freezer. In order to set values for freezer partition, press this button. Use this button also to activate SF mode.

### ALARM LIGHT

In case of a problem within the freezer or the door is left open, the alarm LED will illuminate red.

### SUPER FREEZER MODE

When would it be used?

- To freeze huge quantities of food.
- To freeze food quickly.
- To freeze fresh food.
- To store seasonal food for a long time.

Please keep this instruction manual for future reference





## How to use?

- Press temperature set button until super freezing light comes on.
- Super freezing LED will light during this mode.
- Maximum amount of fresh food (in kilograms) to be frozen within 24 hours is 15kg.
- For optimal appliance performance in maximum freezer capacity, set the appliance to active SF mode 24 hours before you put the fresh food into the freezer.

## During this mode:

If you press temperature set button, the mode will be cancelled and the setting will be restored from -16.

### NOTE:

“Super Freezer” mode will be automatically cancelled after 24 hours or when freezer sensor temperature drops beneath -32 °C.

## FREEZER TEMPERATURE SETTINGS

- The initial temperature of the Setting Display is -18°C.
- Press freezer setting button once.
- Every time you press the button, the setting temperature will decrease. (-16°C, -18°C, -20°C, super freezing)
- If you press the freezer setting button until the super freezer symbol is displayed, and you do not press any button within the following 3 seconds, the Super Freezing symbol will blink and now be set.
- If you keep on pressing, it will restart from last value.

Please keep this instruction manual for future reference



## WARNINGS ABOUT TEMPERATURE ADJUSTMENTS

- Your temperature adjustments will not be deleted when an energy breakdown occurs.
- Temperature adjustments should be made according to the frequency of door openings, the quantity of food kept inside the freezer and ambient temperature of the place of your freezer.
- Your freezer should be operated up to 24 hours according to the ambient temperature without interruption after being plugged in to be completely cooled.
- Do not open doors of your freezer frequently and do not place much food inside it during this period.
- A 5 minute delaying function is applied to prevent damage to the compressor of your freezer, when you take the plug off and then plug it on again to operate it or when an energy breakdown occurs. Your freezer will start to operate normally after 5 minutes.
- Your freezer is designed to operate in the ambient temperature intervals stated in the standards, according to the climate class stated on the rating label. We do not recommend operating your freezer out of stated temperatures value limits in terms of cooling effectiveness.
- This appliance is designed for use at an ambient temperature within the 10°C - 43°C range.

CLIMATE CLASS	AMBIENT TEMPERATURE °C
T	Between 16 and 43 (°C)
ST	Between 16 and 38 (°C)
N	Between 16 and 32 (°C)
SN	Between 10 and 32 (°C)

Please keep this instruction manual for future reference





## ICE MACHINE

- Take out the ice making tray
- Fill the water to the line.
- Place the ice making tray in its original position
- When ice cubes are formed, twist the lever to drop ice cubes into the icebox.

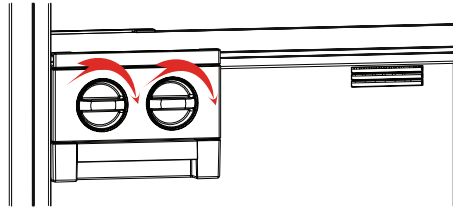

### NOTE:

- Do not fill the icebox with water to make ice. This may damage it.
- The movement of the ice maker may be difficult while the freezer is running. In such a case it should be cleaned by removing the glass shelves.

## REMOVING THE ICE MAKER

- Remove the freezer glass shelves
- Remove the icemaker by pulling left or right on the shelf.

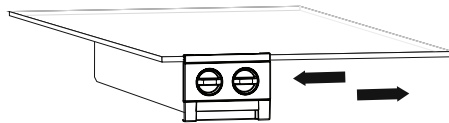

You can remove the icemaker to increase the available volume in the freezer compartment.

Please keep this instruction manual for future reference

Instruction manual RiF1795 15



## ARRANGING FOOD IN THE APPLIANCE

- Use your freezer to keep frozen food for a long time and to produce ice.
- Do not place food you want to freeze next to frozen food.
- You should freeze your food (meat, minced meat, fish etc) in portions that allow consuming in a time.
- Do not put fresh and warm food with frozen food side by side as it can thaw the frozen food.
- While freezing fresh food (i.e. meat, fish and mincemeat) divide them in parts in order to use in one time.
- For storing the frozen food; the instructions shown on frozen food packages should always be followed carefully and if no information is provided, food should not be stored for more than 3 months from the purchased date.
- Maximum load; if you want to load large quantities and use the maximum net capacity, you can remove the drawers (Except the bottom one). You can store bulky items directly on the shelves.
- When buying frozen food ensure that these have been frozen at suitable temperatures and that the packing is intact.
- Frozen food should be transported in appropriate containers to maintain the quality of the food and should be returned to the freezing surfaces of the unit in the shortest possible time.
- If a package of frozen food shows signs of humidity and abnormal swelling it is probable that it has been previously stored at an unsuitable temperature and that the contents have deteriorated.
- The storage life of frozen food depends on the room temperature, thermostat setting, how often the door is opened, the type of food and the length of time required to transport the product from the shop to your home. Always follow the instructions printed on the package and never exceed the maximum storage life indicated.

Please keep this instruction manual for future reference



**- If you would use maximum freezing capacity of your freezer:**

Move the frozen food in the upper baskets to other baskets and activate "Fast Freezing" mode. "Fast Freezing" mode will be deactivated automatically after 24 hours. Place the foods you want to freeze in the upper basket of the freezer without exceeding the freezing capacity of your freezer. (Your freezer has the capacity to freeze 15 kg at 25°C and 14 kg at 32°C) Then reactivate the "Fast Freezing" mode. You can put your food next to other frozen food after they are frozen (minimum 24 hours after "Fast Freezing" mode is activated for the 2nd time).

**- If you would freeze about 3 kg food in your freezer:**

Place your fresh foods without touching other frozen food and activate "Fast Freezing" mode. You can put your fresh foods next to other frozen food after they have frozen (after minimum 24 hours).

- Do not re-freeze the frozen goods after defrosting. This may cause health issues like food poisoning.
- Do not place hot foods in the freezer before cooling them. This may cause already frozen foods to spoil in the freezer.
- When you are buying frozen food, make sure they have been frozen in proper conditions and the package is undamaged.
- Follow the instructions for storing conditions on the package of the frozen food while storing them. If there is no explanation, food must be consumed in a short time.
- If the package of frozen food is humid and smells bad, it may be stored under inappropriate conditions and spoiled. Do not buy this kind of food!
- Storing time for frozen food may differ according to the ambient temperature, frequency of door openings, thermostat adjustments, type of food and the time between the buying of the food and placing of the food in the freezer. Always follow instructions on the package and do not exceed the specified storing period.

Please keep this instruction manual for future reference



## CLEANING AND MAINTENANCE

**Make sure to unplug the freezer before starting to clean it.**

- Do not clean the appliance by pouring water on to it.
- Make sure that no water enters the light fixing and other electrical components.
- The freezer should be cleaned periodically using a solution of bicarbonate of soda and lukewarm water.
- Clean the accessories separately with soap and water. Do not clean them in the dishwasher.
- Do not use abrasive products, detergents or soaps. After washing, rinse with clean water and dry carefully. When you have finished cleaning, reconnect the plug to the mains supply with dry hands.
- Clean the condenser with a broom at least twice a year. This will help you to save on energy costs and increase productivity.

### THE POWER SUPPLY MUST BE DISCONNECTED

## DEFROSTING

Your freezer defrosts automatically. Water produced by defrosting flows into the evaporating container passing through water collecting grooves, and vaporizes here by itself

## REPLACING THE LED STRIP

LED lights should be changed by authorised personnel only. please contact an electrician, or Caple service for assistance - 0117 938 7420.

Please keep this instruction manual for future reference





## TRANSPORTATION AND REPOSITIONING

- The original packages and foamed polystyrene (PS) can be retained if required.
- During transportation, the appliance should be secured with a wide string or a strong rope. The instructions written on the corrugated box must be followed while transporting.
- Before transporting or changing the installation position, all the moving objects (ie, drawer, Ice maker...) should be taken out or fixed with bands in order to prevent them from getting damaged.
- Carry your freezer in the upright position.

Please keep this instruction manual for future reference

Instruction manual RiF1795 19





## TROUBLESHOOTING

ALARM INDICATOR LED IS TURNING ON	ERROR TYPE	WHY	WHAT TO DO
	"Failure Warning"	There is/are some part(s) Out of order or there is a failure in cooling process	Check if the door is open or not. If the door is not open, call Caple service for assistance as soon as possible

If your freezer is not working properly, it may be a minor problem, therefore check the following, before calling an electrician to save time and money.

### WHAT TO DO IF YOUR APPLIANCE DOES NOT OPERATE;

**Check that;**

- There is no power,
- The general switch in your home is disconnected ,
- The socket is not sufficient. To check this, plug in another appliance that you know which is working into the same socket.

### WHAT TO DO IF YOUR APPLIANCE PERFORMS POORLY;

**Check that;**

- You have not overloaded the appliance ,
- The freezer temperature is set to -16.
- The doors are closed perfectly ,
- There is no dust on the condenser ,
- There is enough space at the rear and side walls.

### IF YOUR FREEZER IS OPERATING TOO LOUDLY;

**Normal Noises**

**Cracking (Ice cracking) Noise:**

- During automatic defrosting.
- When the appliance is cooled or warmed (due to expansion of appliance material).

**Short cracking:** Heard when the thermostat switches the compressor on/ off.

Please keep this instruction manual for future reference





**Compressor noise: Normal motor noise.** This noise means that the compressor is operating normally. The compressor may cause more noise for a short time when it is activated.

**Bubbling noise:** This noise is caused by the flow of the refrigerant in the tubes of the system.

**Water flow noise:** Normal flow noise of water flowing to the evaporation container during defrosting. This noise can be heard during defrosting.

**Air blowing / Fan noise:** Normal fan noise. This noise can be heard during normal operation of the system due to the circulation of air.

**If the edges of freezer cabinet that the door joint contact are warm;** Especially in summer (hot weather), the surfaces that the joint contact may get warmer during the operation of the compressor, this is normal.

**If humidity builds up inside the freezer;**

- Are all food packed properly? Are the containers dried before placing them in the freezer?
- Is the freezers door opened frequently? Humidity of the room gets in the freezer when the doors are opened. Humidity build up will be faster when you open the doors more frequently, especially if the humidity of the room is high.

**If the door is not opened and closed properly;**

- Do the food packages prevent closing of the door?
- Are the drawers placed properly?
- Are door seals / joints broken or torn?
- Is your freezer on a level surface?

**Recommendations**

To stop the appliance completely, unplug from main socket (for cleaning and when the door is left open)

Please keep this instruction manual for future reference



## ENERGY SAVING TIPS

1. Install the appliance in a cool, well ventilated room, but not in direct sunlight and not near a heat source (radiator, cooker.. etc). Otherwise use an insulating plate.
2. Allow warm food and drinks to cool down outside the appliance.
3. Cover drinks or other liquids when placing them in the appliance otherwise humidity increases in the appliance. Therefore, the working time gets longer. Also covering drinks and other liquids helps to preserve smell and taste.
4. Try to avoid keeping the doors open for long periods or opening the doors too frequently as warm air will enter the cabinet and cause the compressor to switch on unnecessarily often.
5. Keep the covers of the different temperature compartments (crisper, chiller ...etc) closed.
6. Door gasket must be clean and pliable. Replace gaskets if worn.

Please keep this instruction manual for future reference





## VENTILATION REQUIREMENTS

The main consideration when installing a refrigeration product into a cabinet is ventilation. The heat removed from the appliance needs to be dissipated into the room. Failure to correctly ventilate the product can result in increased running costs and premature failure. It will also invalidate the guarantee provided with the appliance.

An air intake in the plinth is required to allow for the correct air flow (recommended 500mm x 75mm). If preferred a decorative stainless steel plinth grille is available, product code: GRILL/SENSE600. This can be purchased from your retailer or [www.caple.co.uk](http://www.caple.co.uk).

To ensure the correct operation of the appliance it is important the top of the housing is not blocked off. The top of the cabinet needs to be vented into the room, the recommended minimum size of the vent opening is 500x75mm.

There should also be space at the rear of the cabinet to allow the cool air to be drawn over the condenser. This should also be at least 500mm x 75mm. The more air available to circulate the product, the more efficiently it will operate

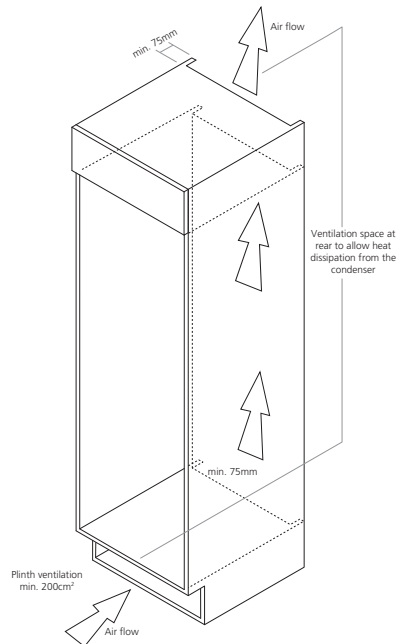

Please keep this instruction manual for future reference

Instruction manual RiF1795 23



## TECHNICAL FICHE

PRODUCT FICHE	
Brand	CAPLE
Model	RIF1795
Product category	8 (Freezer)
Energy class	A+
Annual energy consumption*	297 kWh
Total gross	221 l
Total net volume	197 l
Refrigerator gross volume	
Refrigerator net volume	
Chiller compartment net volume	
Freezer gross volume	221 l
Freezer net volume	197 l
Star rating	4
Refrigeration system	FROST FREE
Temperature rise time (-18°C/-9°C)	9 Hours
Freezing capacity	15 Kg / 24 h
Climate class **	T/SN (10°C - 43°C)
Noise emission	41 dB(A)

\* Energy consumption of 297 kWh per year, calculated on the basis of results obtained in 24 hours under normalised test conditions. Real energy consumption depends on the conditions in which the equipment is used as well as where it is placed.

\*\*This appliance is designed for use at an ambient temperature within the 10°C - 43°C range.

Please keep this instruction manual for future reference



Please keep this instruction manual for future reference

Instruction manual RiF1795 25





Please keep this instruction manual for future reference





Please keep this instruction manual for future reference

Instruction manual RiF1795 27





Caple Service  
Fourth Way  
Avonmouth  
Bristol  
BS11 8DW

t: 0117 938 7420  
e: [service@caple.co.uk](mailto:service@caple.co.uk)  
[www.caple.co.uk](http://www.caple.co.uk)

Version 2

Please keep this instruction manual for future reference

