

# Built-under larder fridge instruction manual

## RBL4



# CONTENTS

Warnings	3
Installation warnings	6
Before using your fridge	10
How to operate	10
Food storage	11
Cleaning and maintenance	11
Defrosting the fridge	12
Replacing the LED light	12
Transportation and repositioning	13
Troubleshooting	13
Energy saving tips	15
Parts of the appliance	16
Installation instructions	17
Electrical connection	25
Technical product fiche	26
Caple contact details	28

## **WARNING:**

- Keep ventilation openings, in the appliance enclosure or in the built-in structure, clear of obstruction.
- Do not use mechanical devices or other means to accelerate the defrosting process, other than those recommended by the manufacturer.
- Do not use electrical appliances inside the food storage compartments of the appliance, unless they are of the type recommended by the manufacturer.
- Do not damage the refrigerant circuit.
- To avoid a hazard due to the instability of the appliance, it must be fixed in accordance with the instructions.

## **WARNING:**

- This appliance uses R600a as a refrigerant. You should be careful during shipment and installation to prevent your appliance's cooler elements from being damaged. R600a is an environmentally friendly and natural gas however it is explosive. In the event of a leak caused by damage to the cooler elements, move your fridge from open flames or heat sources and ventilate the room where the appliance is located for a few minutes.
- Whilst carrying and positioning the fridge, take care not to damage the cooler gas circuit.

## **WARNING:**

- Do not store explosive substances such as aerosol cans with a flammable propellant in this appliance.
- This product is not designed for commercial use, it is a household appliance only. It is not intended to be used in:
  - Staff kitchen areas in shops, offices and other working environments.
  - Bed and breakfast type environments.
  - By clients in hotels, motels and other residential type environments.
- If the socket does not match the refrigerator plug, it must be replaced by a Caple approved engineer or similar qualified persons in order to avoid a hazard.
- This appliance is not intended for use by persons (including children) with reduced physical, sensory or mental capabilities, or lack of experience and knowledge, unless they have been given supervision or instruction concerning use of the appliance by a person responsible for their safety. Children should be supervised to ensure that they do not play with the appliance.
- A specially grounded plug has been connected to the power cable of your refrigerator. This plug should be used with a specially grounded socket of 13 amps. If there is no such socket in your house, please have it installed by an authorized electrician.

- This appliance can be used by children aged from 8 years and above and persons with reduced physical, sensory or mental capabilities or lack of experience and knowledge if they have been given supervision or instruction concerning use of the appliance in a safe way and understand the hazard involved.
- Children should not play with the appliance.
- Cleaning and user maintenance should not be made by children without supervision.
- If the supply cord is damaged, it must be replaced by a Caple approved engineer or similar qualified persons in order to avoid a hazard.

## **NOTE:**

- Please read the instruction manual carefully before installing and using your appliance. Caple can not be held responsible for damage incurred due to misuse.
- Follow all instructions on your appliance and instruction manual, and keep this manual in a safe place to resolve problems that may occur in the future.
- This appliance is produced for domestic use only. It is not suitable for commercial use. Such use will cause the guarantee of the appliance to be invalid and Caple will not be responsible for losses incurred.

## SAFETY WARNINGS

- Do not use multiple sockets or extension cords.
- Do not plug in damaged, torn or old plugs.
- Do not pull, bend or damage the cord.
- This appliance is designed for use by adults, do not allow children to play with the appliance or hang on the door.
- Do not plug-in or un-plug from the socket with wet hands to prevent electrocution!
- Do not place explosive or flammable material in your fridge for your safety. Place drinks with higher alcohol amount vertically and by closing their necks tightly in the fridge.
- Do not cover the body or top of fridge with lace. This affects the performance of your fridge.
- Fix the accessories in the fridge during transportation to prevent damage to accessories.

## INSTALLATION WARNINGS

Before starting to use your fridge, you should pay attention to the following points:

- Operating voltage for your fridge is 220-240 V at 50Hz.
- The plug must be accessible after installation.

- There may be an odour when you first switch on the appliance. It will disappear after the appliance starts to cool.
- Before making the connection to the power supply, ensure that the voltage on the rating plate corresponds to the voltage of electrical system in your home.
- Insert the plug into a socket with an efficient ground connection. If the socket has no ground contact or the plug does not match, we suggest you call an authorised electrician for assistance.
- The appliance must be connected with a properly installed fused socket. Power supply (AC) and voltage at the operating point must correspond with the details on the rating plate of the appliance rating.
- We do not take responsibility for damages that occur due to ungrounded usage.
- Place your fridge in a place where it won't be exposed to direct sunlight.
- Your fridge should never be used outdoors or left in the rain.
- Your appliance should be at least 50 cm away from hobs, gas ovens and heater cores, and should be at least 5 cm away from electrical ovens.
- When your fridge is placed next to a deep freezer, there should be at least 2 cm between them to prevent humidity on the outer surface.

- Do not place heavy items on the appliance.
- Clean the appliance thoroughly, especially in the interior, before use (See Cleaning and Maintenance).
- Installation procedure is given in the Installation Manual. This product is intended to be used in proper kitchen units only.
- The adjustable front legs should be adjusted to an appropriate height to allow your freezer to operate in a stable and proper way. You can adjust the legs by turning them clockwise (or in the opposite direction). This should be done before placing food in the freezer.
- Before using your fridge, wipe all parts with warm water added with a tea spoonful of sodium bicarbonate, and then rinse with clean water and dry.
- When positioning the appliance, ensure the supply cord is not trapped or damaged.
- Do not locate multiple portable socket-outlets or portable power supplies at the rear of the appliance.
- Do not use plug adapter.



Symbol ISO 7010 W021

Warning; Risk of fire / flammable materials



## ENVIRONMENTAL PROTECTION

Waste electrical products should not be disposed of with household waste. Please recycle where facilities exist. Check with your Local Authority or retailer for recycling advice. This appliance is marked according to the European directive 2002/96/EC on Waste Electrical and Electronic Equipment (WEEE).

By ensuring this product is disposed of correctly, you will help prevent potential negative consequences for the environment and human health, which could otherwise be caused by inappropriate waste handling of this product. The symbol on the product indicates that this product may not be treated as household waste. Instead it shall be handed over to the applicable collection point for the recycling of electrical and electronic equipment. Disposal must be carried out in accordance with local environmental regulations for waste disposal.

For more detailed information about treatment, recovery and recycling of this product, please contact your local council, your household waste disposal service or the retailer where you purchased the product.

## CE DECLARATIONS OF CONFORMITY **CE**

This appliance has been manufactured to the strictest standards and complies with all applicable legislation, Low Voltage Directive (LVD) and Electromagnetic Compatibility (EMC).

## BEFORE USING YOUR FRIDGE

- When the appliance is situated for the first time or after transportation, keep your fridge in the upright position for 12 hours before connecting to the mains electricity. Otherwise, you may damage the compressor.
- Your fridge may have a smell when it is operated for the first time; the smell will fade away when your fridge starts to cool.

## HOW TO OPERATE THE APPLIANCE

### Thermostat setting

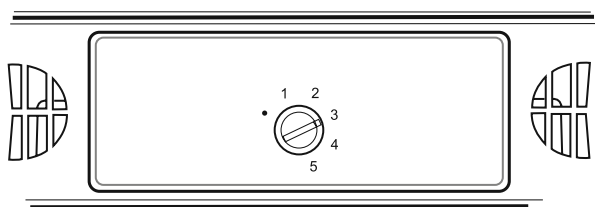

The thermostat automatically regulates the inside temperature of the refrigerator. By rotating the knob from position 1 to 5, colder temperatures can be obtained.

### IMPORTANT NOTE:

Do not try to rotate knob beyond 1 position it will stop your appliance.

- For short-term storage of food in the fridge, you can set the knob between minimum and medium position (1-3).
- For long-term storage of food in the fridge, you can set knob medium position (3-4).
- Note that; the ambient temperature, temperature of the freshly stored food and how often the door is opened, affects the temperature in the fridge. If required, change the temperature setting.
- When you first switch on the appliance, you should ideally try to run it without any food in for 24 hours and not open the door. If you need to use it straight away, try not to put much food inside.
- If the unit is switched off or unplugged, you must allow at least 5 minutes before restarting in order not to damage the compressor.
- Larders (coolers) do not have a freezer compartment but can cool up to 4 - 6 °C.

## FOOD STORAGE

The fridge is used for storing fresh foods.

- Do not place food in direct contact with the rear wall of the refrigerator. Leave some space around food to allow circulation of air.
- Do not place hot food or evaporating liquid in the refrigerator.
- Always store food in closed containers or wrapped.
- To reduce humidity and avoid formation of frost, never place liquids in unsealed containers in the refrigerator.
- Meat of all types, wrapped in packages, is recommended to be placed on the glass shelf just above the vegetable bin, where the air is colder.
- You can put fruits and vegetables into the crisper without packing.
- To avoid the cold air escaping, try not to open the door too often, and not leave the door open for a long time.

## CLEANING AND MAINTENANCE

- Disconnect the appliance from the power supply before cleaning.
- Do not wash your fridge by pouring water on it.
- The refrigerator should be cleaned periodically using a solution of bicarbonate of soda and lukewarm water.
- You can wipe the inner and outer sides with a soft cloth or a sponge using warm and soapy water.
- Clean the accessories separately with soap and water. Do not put them in the dishwasher.
- Do not use abrasive products, detergents or soaps. After washing, rinse with clean water and dry carefully. When the cleaning operations have been completed, reconnect the plug with dry hands..



Please keep this instruction manual for future reference

## DEFROSTING THE REFRIGERATOR

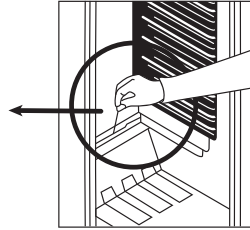
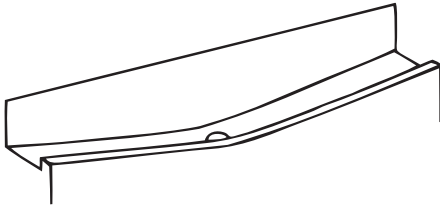

- Defrosting occurs automatically in refrigerator during operation; the defrost water is collected by the evaporating compartment and evaporates automatically.
- The defrost water drain hole should be cleaned periodically with the defrost drain plug removed to prevent the water from collecting in the bottom of the refrigerator instead of flowing out.
- You can also pour ½ glass of water into the drain hole to clean inside.

## REPLACING THE LED LIGHT

The LED light must be replaced by an authorised engineer or similar only. For more information please contact Caple service – 0117 938 7420 or [service@caple.co.uk](mailto:service@caple.co.uk)

## TRANSPORTATION AND REPOSITIONING

Transportation and changing of installation position.

- Original packaging and foam may be kept for re-transportation (optionally).
- You should fasten your fridge with thick packaging, bands or strong cords and follow the instructions for transportation on the packaging for re-transportation.
- Remove movable parts (shelves, accessories, vegetable bins etc.) or fix them into the fridge using bands or tape.

## TROUBLESHOOTING

If your refrigerator is not working properly, it may be a minor problem, therefore check the following, before calling for after sales service.

### **The appliance does not operate, Check if;**

- There is a power failure.
- The mains plug is not properly plugged in, or is loose.
- The thermostat setting is on position "•".
- The socket is defective. To check this, plug in another appliance that you know is working into the same socket.

### **The appliance performs poorly; Check if;**

- You have overloaded the appliance.
- The door is not closed perfectly.
- There are not enough ventilation ducts in the kitchen unit as mentioned in the installation manual.

### **If there is noise;**

The cooling gas which circulates in the refrigerator circuit may make a slight noise (bubbling sound) even when the compressor is not running. Do not worry, this is quite normal. If these sounds are different check if;

- The appliance is installed firmly as described in the installation manual.
- Objects in the appliance are vibrating.

**If there is water in the lower part of the refrigerator;****Check if;**

The drain hole for defrost water is clogged (use defrost drain plug to clean the drain hole).

**If your fridge is not cooling enough;**

Your fridge is designed to operate in the ambient temperature intervals stated in the standards, according to the climate class stated in the information label. We do not recommend operating your fridge out of stated temperatures value limits in terms of cooling effectiveness.

CLIMATE CLASS	AMBIENT TEMPERATURE °C
T	Between 16 and 43 (°C)
ST	Between 16 and 38 (°C)
N	Between 16 and 32 (°C)
SN	Between 10 and 32 (°C)

This appliance is designed for use at an ambient temperature within the 10°C - 32°C range.

## RECOMMENDATIONS

- When there is no power, to prevent any compressor problem you should unplug the refrigerator. You should delay plugging back in 5 – 10 minutes.
- If you unplug the refrigerator for any reason you should wait at least 5 min to replug. It is important for avoiding damage to the refrigerator's components.
- The cooling unit of your refrigerator is hidden in the rear wall. Therefore, water droplets or icing may occur on the rear surface of your fridge due to the operation of the compressor in specified intervals. This is normal. There is no need to perform a defrosting operation unless the icing is excessive.
- If you will not use your fridge for a long time (e.g. in summer holidays), put the thermostat to «●» position. After defrosting, clean your fridge and leave the door open to prevent humidity and smell.
- If the problem persists after you have followed all the instructions above, please contact Caple service 0117 938 1900 option: 2.
- The appliance you have purchased is designed for domestic use and can be used only at home for the stated purposes. It is not suitable for commercial or common use. If the consumer uses the appliance in a way that does not comply with these features, we emphasise that the manufacturer and the retailer shall not be responsible for any repair and failure within the guarantee period.

## ENERGY SAVING TIPS

1. Install the appliance in a cool, well ventilated room, but not in direct sunlight and not near heat source (radiator, cooker... etc). Otherwise use an insulating plate.
2. Allow warm food and drinks to cool down outside the appliance.
3. When placing, drinks and liquids they must be covered. Otherwise humidity increases in the appliance, therefore the working time gets longer. Also covering drinks and liquids helps to save smell and taste.
4. When placing food and drinks in the refrigerator, open the appliance door as briefly as possible.
5. Keep the covers closed of any different temperature compartment in the appliance (crisper, chiller... etc).
6. The door gasket must be clean and pliable. Replace gaskets if worn.

Please keep this instruction manual for future reference

## PARTS OF THE APPLIANCE

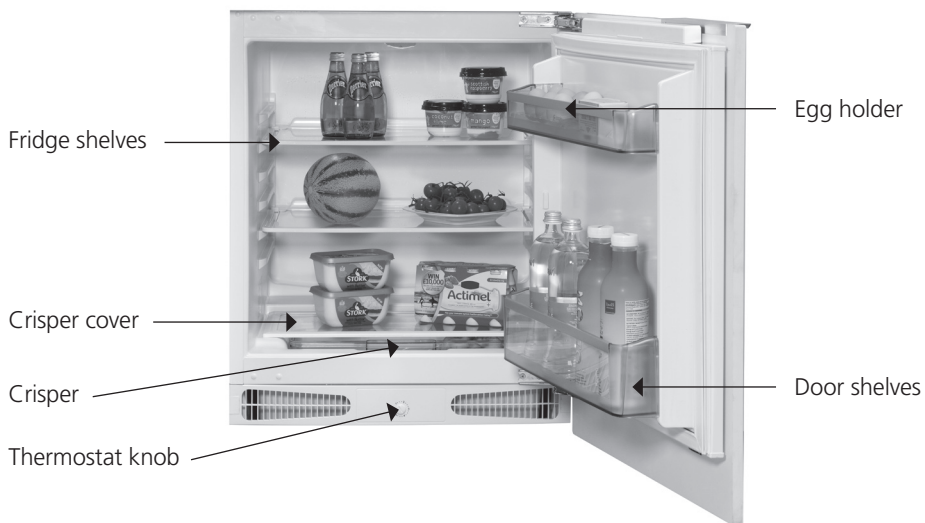

The purpose of this presentation is informing you about the parts of your appliance. The parts may vary depending on the model of the appliance.

# INSTALLATION INSTRUCTIONS

## Installation Kit Contents



1. Wood screw x 17

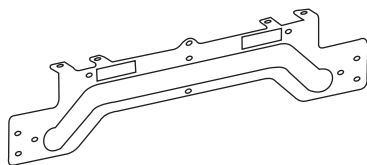

2. Door hanger

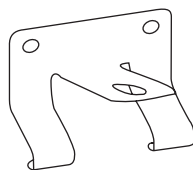

3. Door Bottom Fixings x2

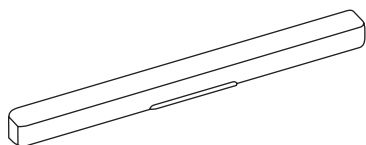

4. Hanger cover

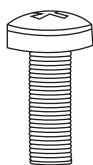

5. Screw



6. Top bracket

## Tools Required

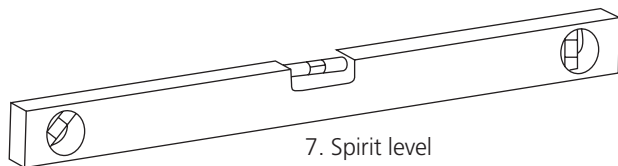

7. Spirit level

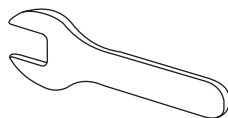

8. Wrench

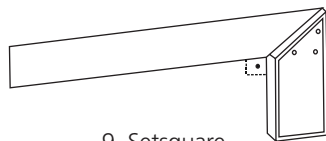

9. Setsquare

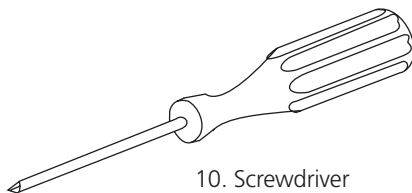

10. Screwdriver

Please keep this instruction manual for future reference

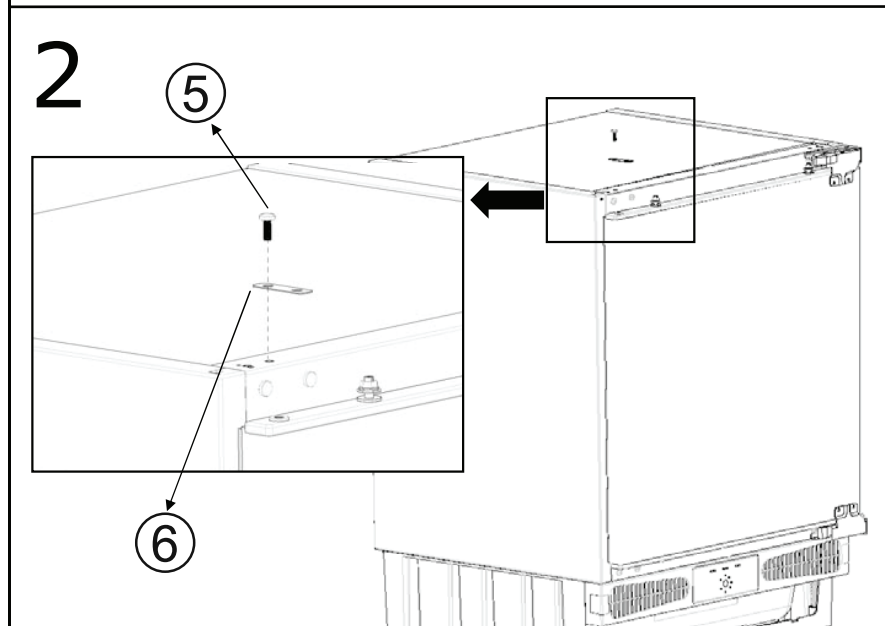
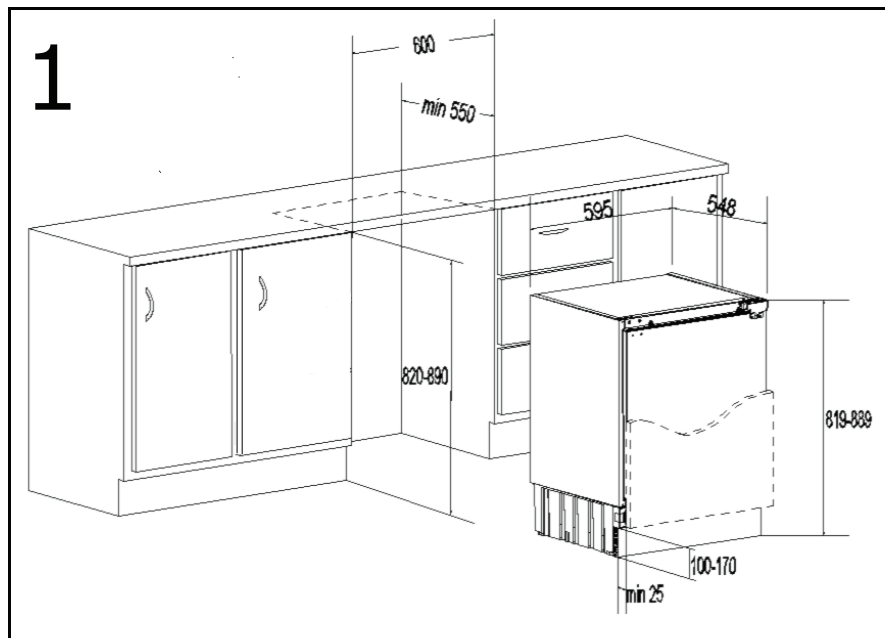

Please keep this instruction manual for future reference

# 3

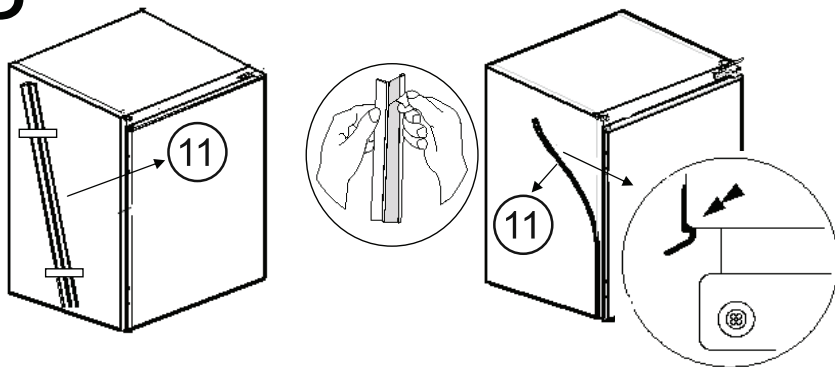

# 4

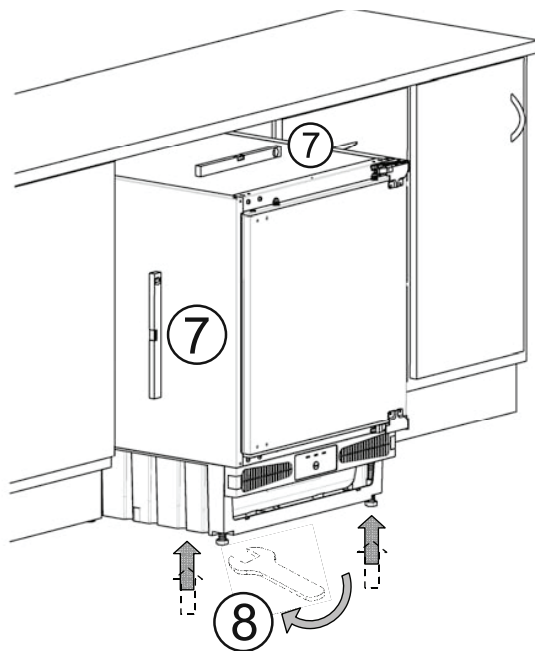

Please keep this instruction manual for future reference

5

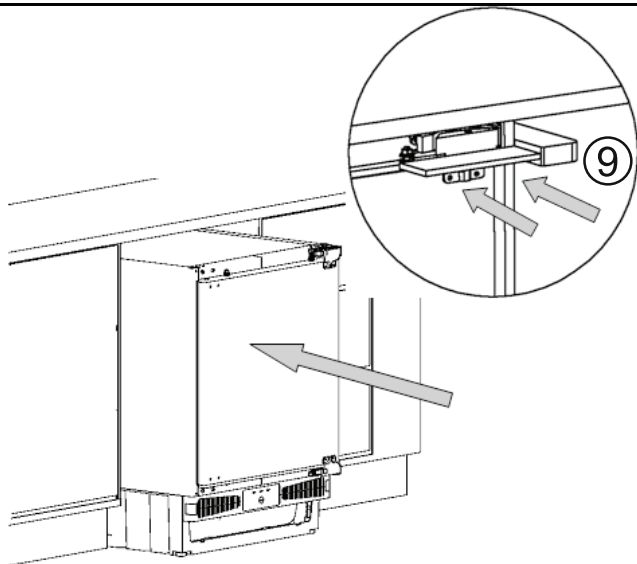

6

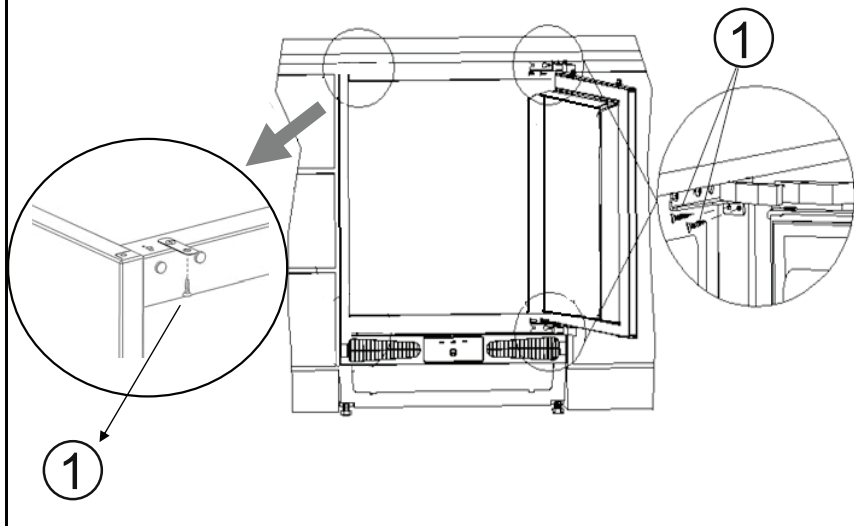

Please keep this instruction manual for future reference

# 7

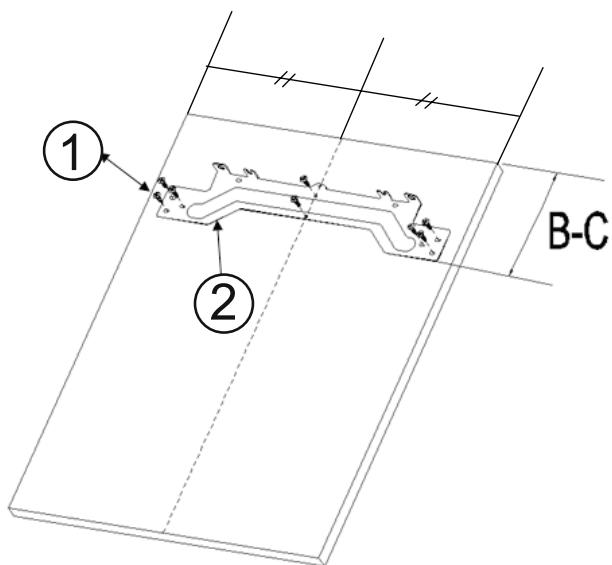
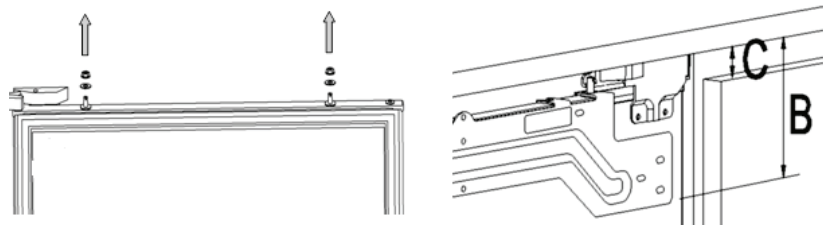

# 8

Please keep this instruction manual for future reference

9

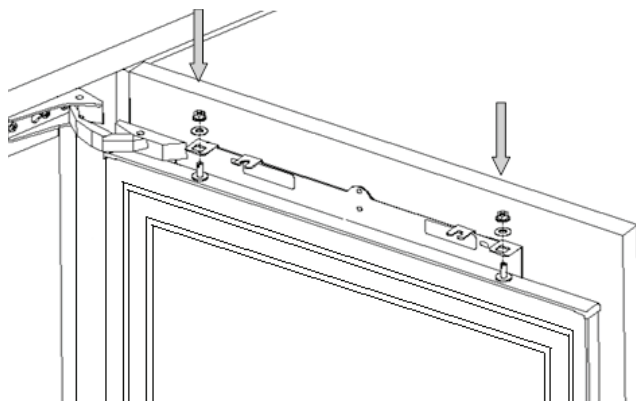

10

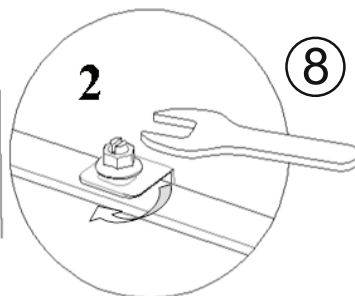
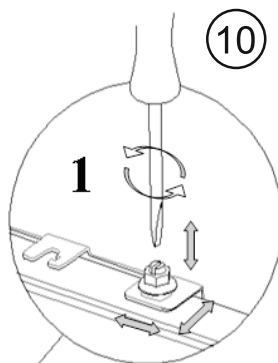
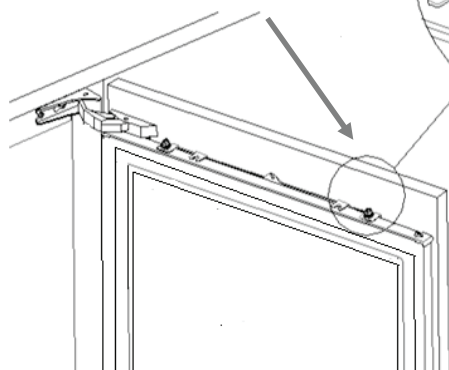
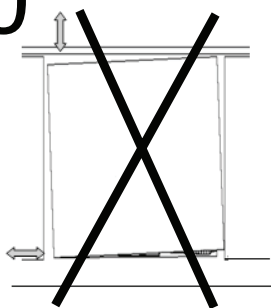

Please keep this instruction manual for future reference

# 11

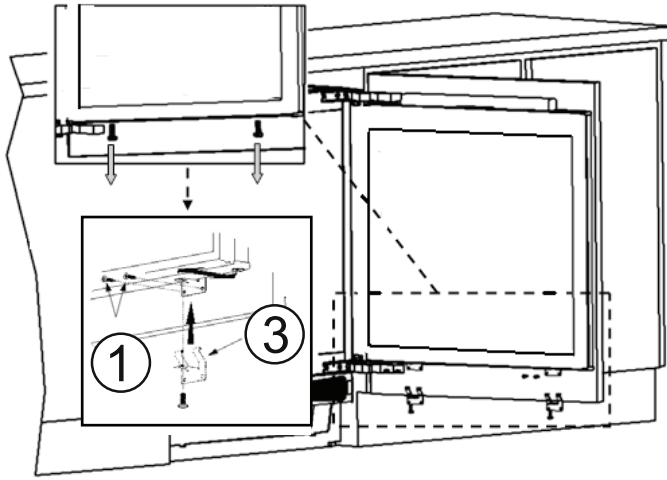

# 12

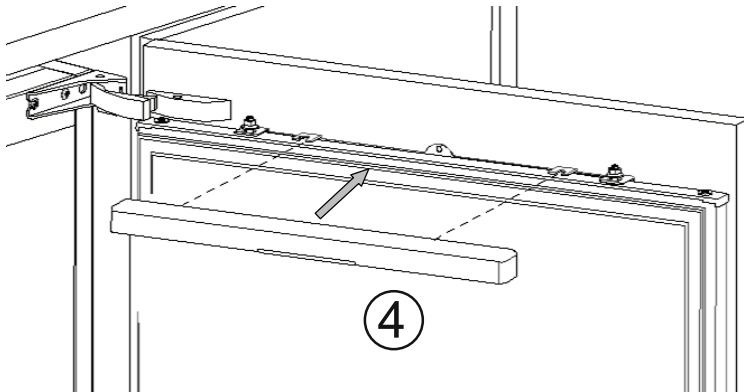

Please keep this instruction manual for future reference

# 13

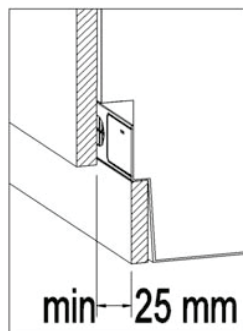
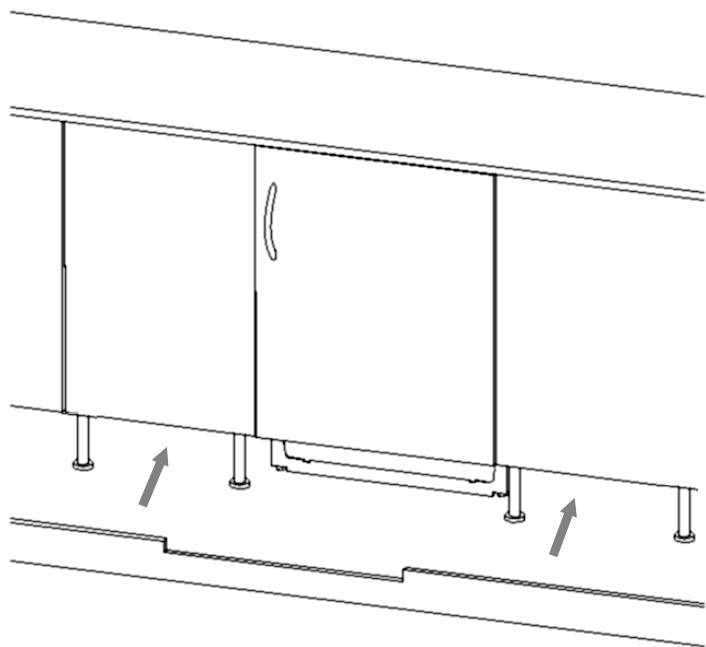

Please keep this instruction manual for future reference

# ELECTRICAL CONNECTION

For your safety please read the following information

## **WARNING: THIS APPLIANCE MUST BE EARTHED.**

This appliance operates from 220-240 volts and should be protected by a 13 amp fuse in the plug.

The appliance is supplied with a standard 13 amp 3-pin mains plug fitted with a 13-amp fuse. Should the fuse require replacement, it must be replaced with a fuse rated at 13 amp and approved to BS1362.

If the mains plug which is fitted is unsuitable for the socket outlet in your home or is removed for any other reason, please follow the instructions below on how to wire a 13 amp 3 pin plug.

## **HOW TO WIRE A 13 AMP PLUG.**

### **IMPORTANT**

The wires in the mains lead on this appliance are coloured in accordance with the following code:

Green and Yellow - Earth

Blue – Neutral

Brown – Live

As the colours may not correspond with the markings identifying the terminals in your plug proceed as follows.

The green and yellow wire must be connected to the terminal in the plug which is marked with the letter E or with the earth symbol or coloured green and yellow.

The blue wire must be connected to the terminal marked N.

The brown wire must be connected to the terminal marked L.

You must make sure the lead is firmly secured under the cord clamp.

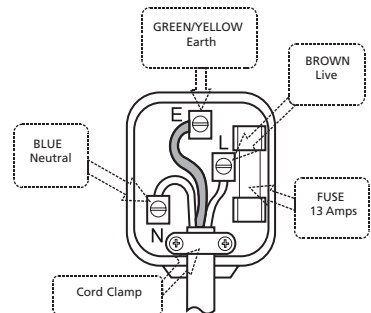

Please keep this instruction manual for future reference

PRODUCT FICHE	RBL4
Product category	1
Energy class	A+
Annual energy consumption*	115 kWh
Total gross volume	136 l
Total net volume	133 l
Refrigerator gross volume	–
Refrigerator net volume	–
Freezer gross volume	–
Freezer net volume	–
Star rating	–
Refrigeration system	Static
Temperature rise time (-18°C/-9°C)	–
Freezing capacity	–
Climate class **	SN (10°C - 32°C)
Noise emission	39 dB (A)

\*Energy consumption of 115 kWh per year, calculated on the basis of results obtained in 24 hours under normal test conditions.

Real energy consumption depends on the conditions in which the equipment is used as well as where it is placed.

\*\*This equipment is designed for use at an ambient temperature within the 10°C - 32°C range.

---

Please keep this instruction manual for future reference

Caple Service  
Fourth Way  
Avonmouth  
Bristol  
BS11 8DW

t: 0117 938 7420  
e: [service@caple.co.uk](mailto:service@caple.co.uk)  
[www.caple.co.uk](http://www.caple.co.uk)

Please keep this instruction manual for future reference