

# Built-under larder freezer instruction manual

## RBF4



# CONTENTS

Warnings	3
Installation warnings	7
Before using your freezer	11
How to operate	11
Food storage	12
Cleaning and maintenance	13
Defrosting the freezer	14
Troubleshooting	15
Energy saving tips	16
Parts of the appliance	17
Installation instructions	18
Electrical connection	26
Technical product fiche	27
Caple contact details	28

## **WARNING:**

- Keep ventilation openings, in the appliance enclosure or in the built-in structure, clear of obstruction.
- Do not use mechanical devices or other means to accelerate the defrosting process, other than those recommended by the manufacturer.
- Do not use electrical appliances inside the food storage compartments of the appliance, unless they are of the type recommended by the manufacturer.
- Do not damage the refrigerant circuit.
- To avoid a hazard due to the instability of the appliance, it must be fixed in accordance with the instructions.

## **WARNING:**

- This appliance uses R600a as a refrigerant. You should be careful during shipment and installation to prevent your appliance's cooler elements from being damaged. R600a is an environmentally friendly and natural gas however it is explosive. In the event of a leak caused by damage to the cooler elements, move your fridge from open flames or heat sources and ventilate the room where the appliance is located for a few minutes.
- Whilst carrying and positioning the fridge, take care not to damage the cooler gas circuit.

- Do not store explosive substances such as aerosol cans with a flammable propellant in this appliance.
- This product is not designed for commercial use, it is a household appliance only. It is not intended to be used in:
  - Staff kitchen areas in shops, offices and other working environments.
  - Bed and breakfast type environments.
  - By clients in hotels, motels and other residential type environments.
- If the socket does not match the refrigerator plug, it must be replaced by a Caple approved engineer or similar qualified persons in order to avoid a hazard.
- This appliance is not intended for use by persons (including children) with reduced physical, sensory or mental capabilities, or lack of experience and knowledge, unless they have been given supervision or instruction concerning use of the appliance by a person responsible for their safety. Children should be supervised to ensure that they do not play with the appliance.
- A specially grounded plug has been connected to the power cable of your refrigerator. This plug should be used with a specially grounded socket of 13 amps. If there is no such socket in your house, please have it installed by an authorized electrician.
- This appliance can be used by children aged from 8

Please keep this instruction manual for future reference

years and above and persons with reduced physical, sensory or mental capabilities or lack of experience and knowledge if they have been given supervision or instruction concerning use of the appliance in a safe way and understand the hazard involved.

- Children should not play with the appliance.
- Cleaning and user maintenance should not be made by children without supervision.
- If the supply cord is damaged, it must be replaced by a Caple approved engineer or similar qualified persons in order to avoid a hazard.

## **NOTE:**

- Please read the instruction manual carefully before installing and using your appliance.
- Caple can not be held responsible for damage incurred due to misuse.
- Follow all instructions on your appliance and instruction manual, and keep this manual in a safe place to resolve problems that may occur in the future.
- This appliance is produced to be used in only a domestic environment and for the specified purposes. It is not suitable for commercial or common use. Such use will cause the guarantee of the appliance to be invalid and Caple will not be responsible for losses incurred.

## SAFETY WARNINGS

- Do not use multiple sockets or an extension cord.
- Do not plug in damaged, torn or old plugs.
- Do not pull, bend or damage the cord.
- This appliance is designed for use by adults, do not allow children to play with the appliance or hang on the door.
- Do not plug-in or pull out the plug from the socket with wet hands to prevent electrocution!
- Do not place glass bottles or beverage cans in the freezer. Bottles or cans may explode.
- Do not place explosive or flammable material in your freezer for your safety. Place drinks with higher alcohol amount vertically and by closing their necks tightly in the freezer.
- When taking out ice made in the freezer, do not touch it with bare hands. Ice may cause ice burns and/or cuts.
- Do not touch frozen goods with wet hands! Do not eat ice-cream and ice cubes immediately after you have taken them out of the freezer!
- Do not re-freeze frozen goods after they have melted. This may cause health issues like food poisoning.
- Do not cover the body or top of freezer with lace. This affects the performance of your freezer.
- Fix the accessories in the freezer during transportation to prevent damage to accessories.

Please keep this instruction manual for future reference

## INSTALLATION WARNINGS

Before starting to use your freezer, you should pay attention to the following points:

- Operating voltage for your freezer is 220-240 V at 50Hz.
- The plug must be accessible after installation.
- There may be an odour when you first switch on the appliance. It will disappear after the appliance starts to cool.
- Before making the connection to the power supply, ensure that the voltage on the rating plate corresponds to the voltage of electrical system in your home.
- Insert the plug into a socket with an efficient ground connection. If the socket has no ground contact or the plug does not match, we suggest you call an authorised electrician for assistance.
- The appliance must be connected with a properly installed fused socket. Power supply (AC) and voltage at the operating point must match with the details on the rating plate of the appliance.
- We do not take responsibility for damages that occur due to ungrounded usage.
- Place your freezer in a place where it won't be exposed to direct sunlight.
- Your freezer should never be used outdoors or left in the rain.

- Your appliance should be at least 50cm away from hobs, Gas ovens and heater cores, and should be at least 5cm away from electrical ovens.
- When your freezer is placed next to a deep freezer, there should be at least 2cm between them to prevent humidity on the outer surface.
- Do not place heavy items on the appliance.
- Clean the appliance thoroughly, especially in the interior, before use (See Cleaning and Maintenance).
- Installation procedure into the kitchen unit is given in the installation manual. This product is intended to be used in proper kitchen units only.
- The adjustable front legs should be adjusted to make sure your appliance is level and stable. You can adjust the legs by turning them clockwise (or in the opposite direction). This should be done before placing food in the fridge.
- Before using your freezer, wipe all parts back with warm water added with a tea spoonful of sodium bicarbonate, and then rinse with clean water and dry. Replace all parts after cleaning.
- The freezer should be placed against a wall with a free distance not exceeding 75 mm.
- When positioning the appliance, ensure the supply cord is not trapped or damaged.

- Do not locate multiple portable socket-outlets or portable power supplies at the rear of the appliance.
- Do not use plug adapter.



Symbol ISO 7010 W021

Warning; Risk of fire / flammable materials



## - ENVIRONMENTAL PROTECTION

Waste electrical products should not be disposed of with household waste. Please recycle where facilities exist. Check with your Local Authority or retailer for recycling advice. This appliance is marked according to the European directive 2002/96/EC on Waste Electrical and Electronic Equipment (WEEE).

By ensuring this product is disposed of correctly, you will help prevent potential negative consequences for the environment and human health, which could otherwise be caused by inappropriate waste handling of this product. The symbol on the product indicates that this product may not be treated as household waste. Instead it shall be handed over to the applicable collection point for the recycling of electrical and electronic equipment. Disposal must be carried out in accordance with local environmental regulations for waste disposal.

For more detailed information about treatment, recovery and recycling of this product, please contact your local council, your household waste disposal service or the retailer where you purchased the product.

## CE DECLARATIONS OF CONFORMITY

This appliance has been manufactured to the strictest standards and complies with all applicable legislation, Low Voltage Directive (LVD) and Electromagnetic Compatibility (EMC).

## BEFORE USING YOUR FREEZER

- When the appliance is situated for the first time or after transportation, keep your fridge in the upright position for 12 hours before connecting to the mains electricity. Otherwise, you may damage the compressor.
- Your fridge may have a smell when it is operated for the first time; the smell will fade away when your fridge starts to cool.

## HOW TO OPERATE THE APPLIANCE

### Thermostat setting

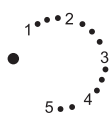
- 
- The freezer thermostat automatically regulates the inside temperature of the compartments. By rotating the knob from position 1 to 5, colder temperatures can be obtained. “●” position shows thermostat is closed and no cooling will be available.

### IMPORTANT NOTE:

Do not try to rotate knob beyond 1 position it will stop your appliance.

### Freezer thermostat setting;

- 1 - 2 :** For short-term storage of food in the freezer compartment, you can set the knob between minimum and medium position.
- 3 - 4 :** For long-term storage of food in the freezer compartment, you can set knob to medium position.
- 5 :** For freezing fresh foods. The appliance will run for colder temperatures.

### NOTE:

The ambient temperature, temperature of the freshly stored food and how often the door is opened, affects the temperature in the freezer compartments. If required, change the temperature setting.

## FOOD STORAGE

- This freezer is used for freezing fresh foods and for storing frozen foods for the period of time indicated on packaging, and for making ice cubes.
- For freezing fresh food; wrap and seal fresh food properly, that is the packaging should be air tight and shouldn't leak. Special freezer bags, aluminium foil (heavy grade), polythene bags and plastic containers are ideal. While freezing food; The maximum amount of fresh food (in kg) that can be frozen in 24 hours is indicated on the appliance label.
- For optimum appliance performance to reach maximum freezing capacity , turn knob to 5 position when placing fresh food in the freezer.
- After placing fresh food in the freezer, 24 hours position 5 is generally sufficient, after 24 hours, reset the thermostat to the desired position.
- **Attention:** In order to save energy, when freezing small amounts of food, reset the thermostat to the desired position. (Recommendation).
- Do not allow the fresh food to be frozen to come into contact with the already frozen food.
- Always mark the date and the content on the pack and do not exceed the stated storage time.
- In case of a power failure or malfunction, the freezer compartment will maintain a sufficiently low temperature for food storage. However, avoid opening the freezer door to slow down the temperature rise within the freezer compartment.
- The maximum amount of fresh foods that can be loaded in the freezer within 24 hours is indicated on the rating label (see Freezing Capacity).
- Never place warm food in the freezer compartment.
- When purchasing and storing frozen food products; ensure that the packaging is not damaged.
- The storage time and the recommended temperature for storing frozen foods are indicated on the packaging. For storing and using, follow the manufacturer's instructions. If no information is provided, food should not be stored for more than 3 months.
- Place frozen food in the freezer compartment as soon as possible after buying it.
- Once the food is thawed, it must not be refrozen; you must cook it as quickly as possible in order to consume or to freeze once again.

Please keep this instruction manual for future reference

- When making ice cubes, fill the ice tray with water and place in freezer compartment. After the water has completely turned into ice, you can twist the tray as shown below to release the ice cubes.

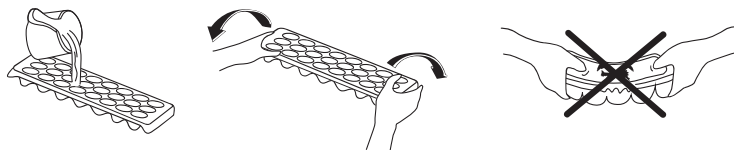

**Storage:** If you want to use the maximum net capacity, you can remove the drawers and store the items directly on the cooling tubes. This will enable you to make use of the entire volume of the compartment.

## CLEANING AND MAINTENANCE

- **Disconnect unit from the power supply before cleaning.**
- Do not clean the appliance by pouring water on it.
- The freezer compartment should be cleaned periodically using a solution of bicarbonate of soda and lukewarm water.
- Clean the accessories separately with soap and water. Do not clean them in the washing machine.
- Do not use abrasive products, detergents or soaps. After washing, rinse with clean water and dry carefully. When the cleaning operations have been completed reconnect the plug of the unit with dry hands.



## DEFROSTING THE FREEZER

Never use sharp metal tools, unless recommended by manufacturer, for this operation as they can damage the refrigeration circuit.

After a period of time, frost will build up in certain areas in the freezer. The frost, accumulated in the freezer, should be removed periodically (use the plastic scraper if available).

Complete defrosting will become necessary if the frost layer exceeds 3-5 mm to maintain the efficiency of the freezer.

- The day before you defrost, set the thermostat dial to position "5" to freeze the foods completely. (Recommendation).
- During defrosting, frozen foods should be wrapped in several layers of paper and kept in a cool place. The inevitable rise in temperature will shorten their storage life. Remember to use these foods within a relatively short period of time.
- Set the thermostat knob to position "•" and switch off the appliance.
- Leave the door open to accelerate defrosting. Remove the defrost water from the compartment.
- If there is defrost water on the freezer floor, you can clear it away by using a sponge.
- Clean the interior by hand with lukewarm water and a little detergent.  
**Never use abrasive products or aggressive cleaning agents.**
- Dry the inside of the unit, plug on the mains, and set the thermostat knob to position "5". After 24 hours, reset the thermostat to the desired position.

## TROUBLESHOOTING

If your freezer is not working properly, it may be a minor problem, therefore check the following, before calling for after sales service.

### **The appliance does not operate, Check if;**

- There is a power failure.
- The mains plug is not properly plugged in, or is loose.
- The thermostat setting is on position "•".
- The socket is defective. To check this, plug in another appliance that you know is working into the same socket.

### **The appliance performs poorly; Check if;**

- You have overloaded the appliance.
- The door is not closed perfectly.
- There are not enough ventilation ducts in the kitchen unit as mentioned in the installation manual.

### **If there is noise;**

The cooling gas which circulates in the freezer circuit may make a slight noise (bubbling sound) even when the compressor is not running. Do not worry, this is quite normal. If these sounds are different check if;

- The appliance is installed firmly as described in the installation manual.
- Objects in the appliance are vibrating.

### **If your fridge is not cooling enough;**

Your freezer is designed to operate in the ambient temperature intervals stated in the standards, according to the climate class stated in the information label. We do not recommend operating your freezer out of stated temperatures value limits in terms of cooling effectiveness.

CLIMATE CLASS	AMBIENT TEMPERATURE °C
T	Between 16 and 43 (°C)
ST	Between 16 and 38 (°C)
N	Between 16 and 32 (°C)
SN	Between 10 and 32 (°C)

This appliance is designed for use at an ambient temperature within the 16°C - 32°C range.

Please keep this instruction manual for future reference

## RECOMMENDATIONS:

- When power is off, to prevent any compressor problem you should un-plug the freezer. You should delay plugging in 5 – 10 minutes after you power supply. If you un-plug the freezer for a reason you should wait at least 5 min to plug it back in. It is important for avoiding damage to freezer's components.
- If you won't be using your freezer for a long time (such as on summer holidays), please disconnect the plug from the socket. Clean your freezer as per this document and leave the door open to prevent any humidification or odour formation.
- If there is still a problem with your freezer although you have followed the instructions in this book, please contact Cable service.

## ENERGY SAVING TIPS

1. Install the appliance in a cool, well ventilated room , but not in direct sunlight and not near a heat source (radiator, cooker.. etc). Otherwise use an insulating plate.
2. Allow warm food and drinks to cool down outside the appliance.
3. When placing drinks and left-overs on the freezer they must be covered. Otherwise humidity increases in the appliance, therefore the working time gets longer. Also covering drinks and left-overs helps to save smell and taste.
4. When placing food and drinks in to the freezer, open the door as briefly as possible.
5. The door gasket must be clean and pliable. Replace gaskets if worn.

## PARTS OF THE APPLIANCE

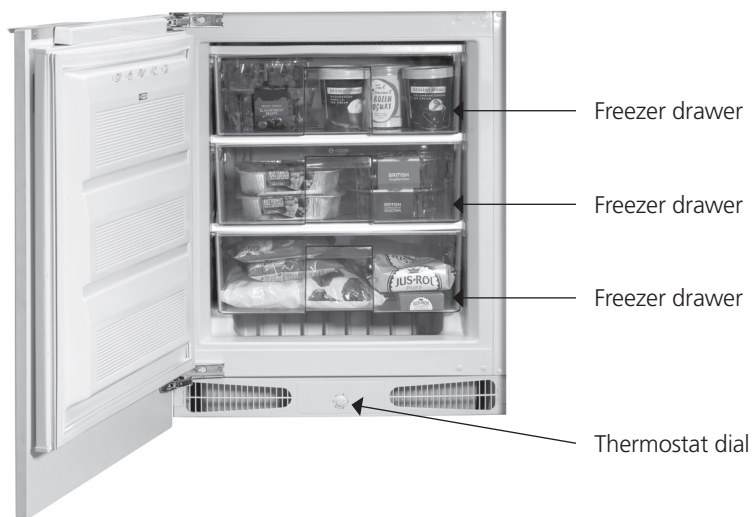

The purpose of this presentation is informing you about the parts of your appliance. The parts may vary depending on the model of the appliance.

Please keep this instruction manual for future reference

## INSTALLATION INSTRUCTIONS

### Installation Kit Contents

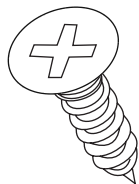

1. Wood screw x 17

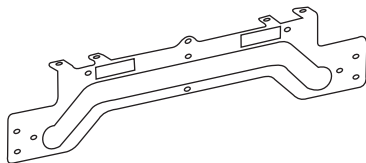

2. Door hanger

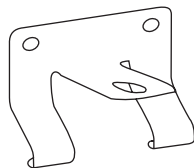

3. Door Bottom Fixings x2

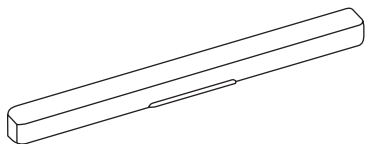

4. Hanger cover

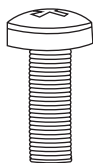

5. Screw



6. Top bracket

### Tools Required

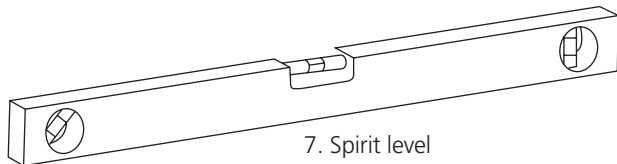

7. Spirit level

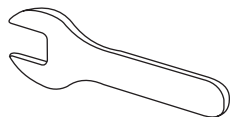

8. Wrench

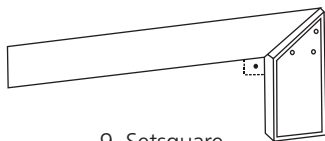

9. Setsquare

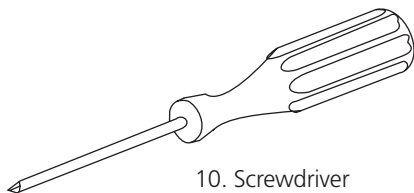

10. Screwdriver

Please keep this instruction manual for future reference

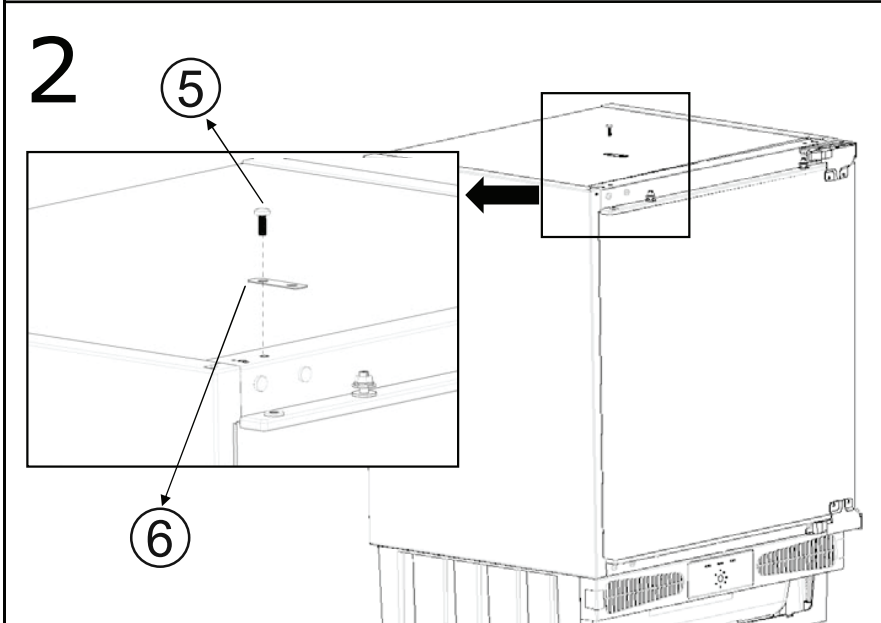
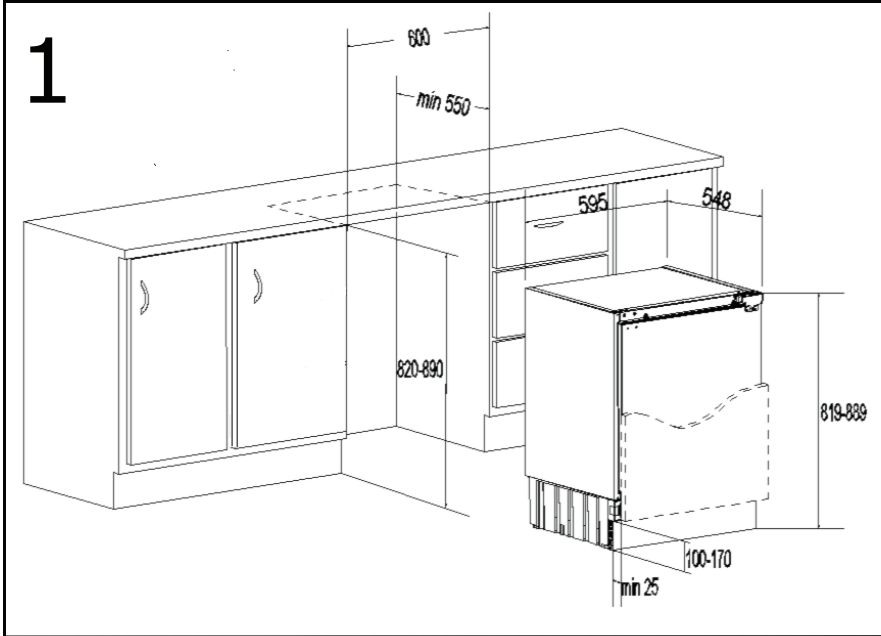

Please keep this instruction manual for future reference

**3**

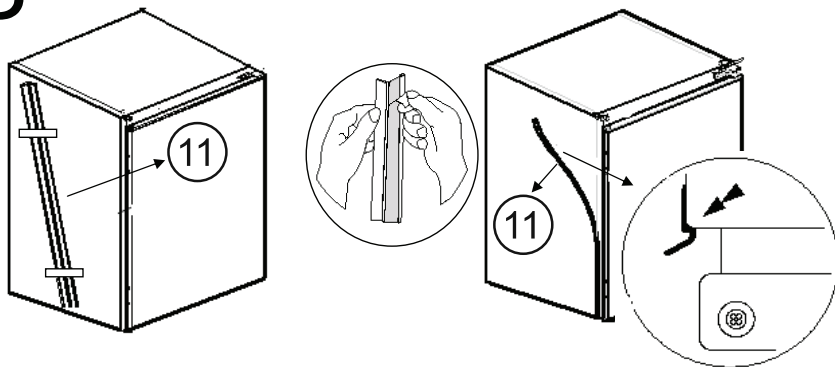

**4**

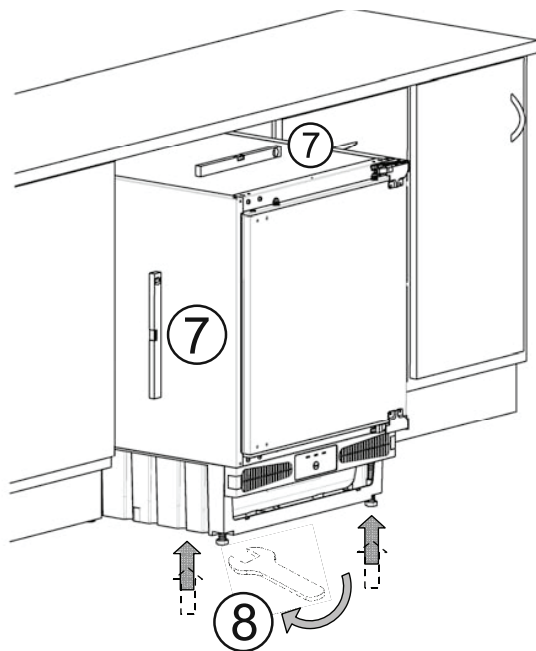

Please keep this instruction manual for future reference

# 5

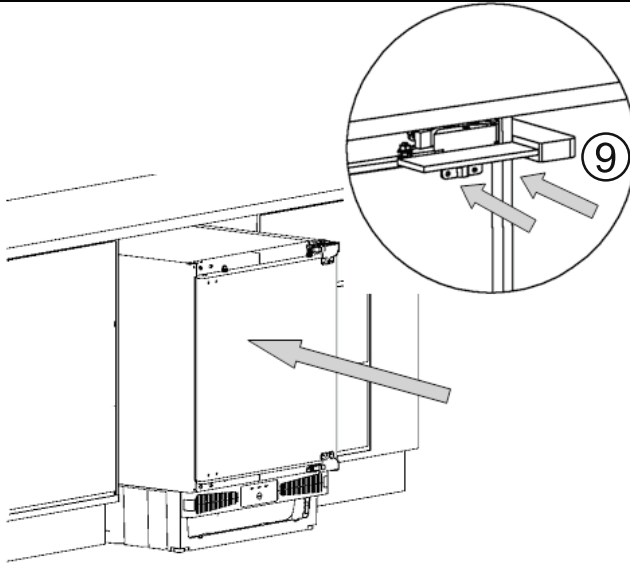

# 6

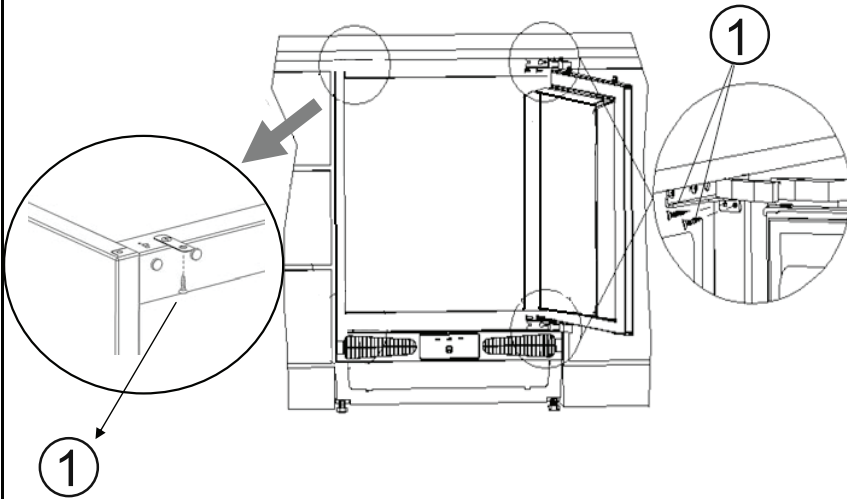

Please keep this instruction manual for future reference

7

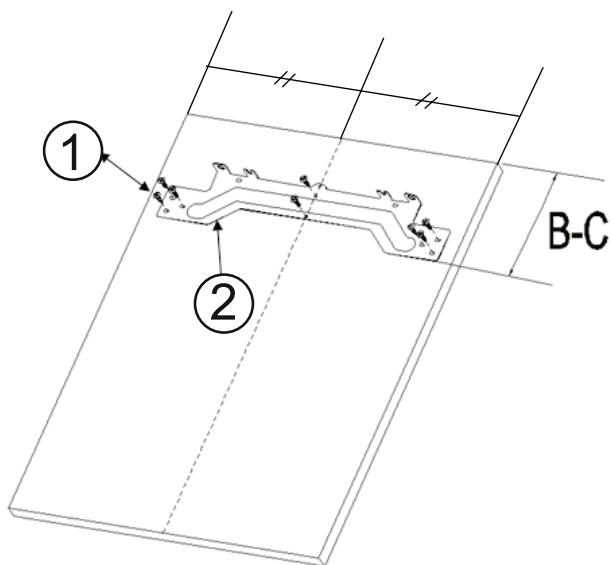
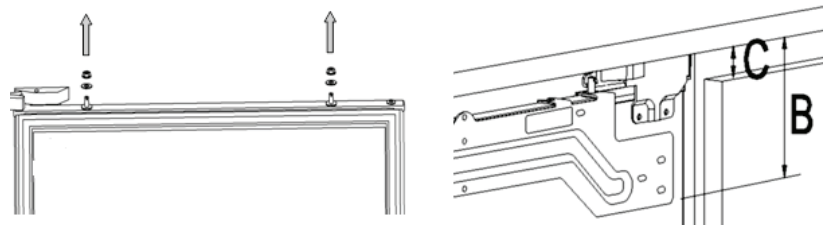

8

Please keep this instruction manual for future reference

9

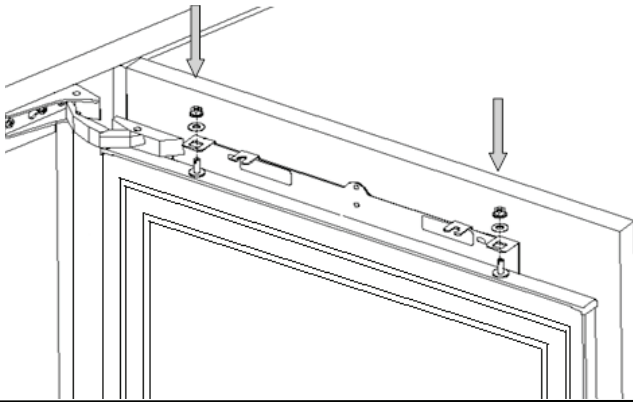

10

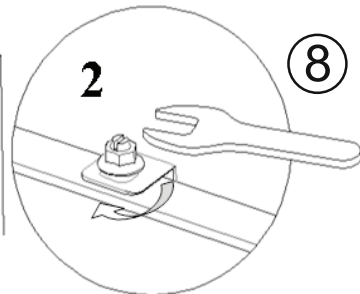
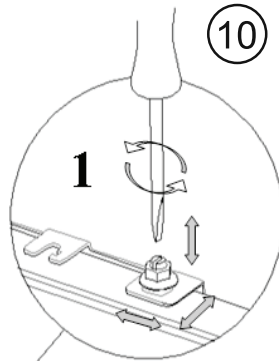
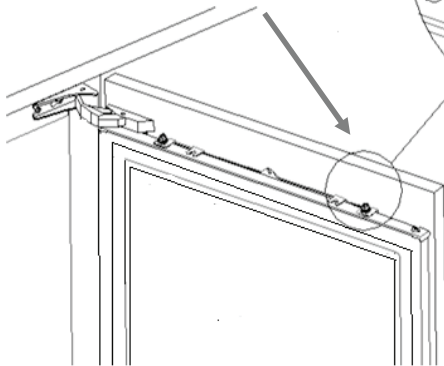
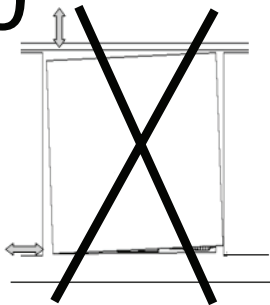

Please keep this instruction manual for future reference

# 11

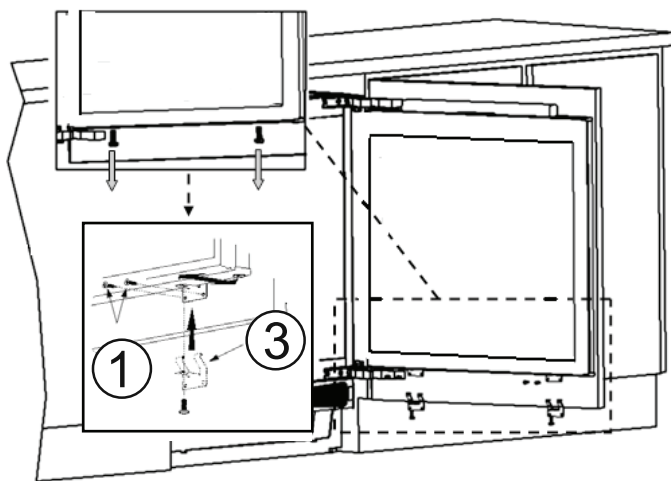

# 12

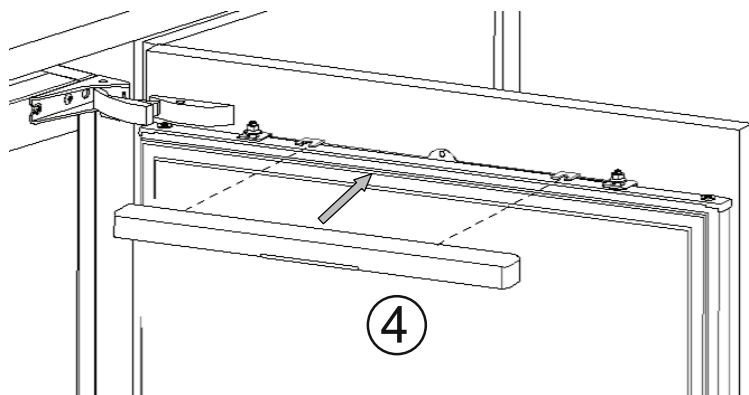

Please keep this instruction manual for future reference

# 13

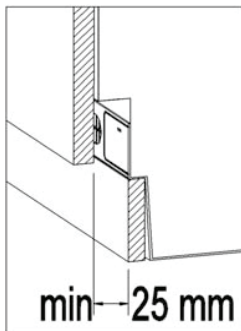
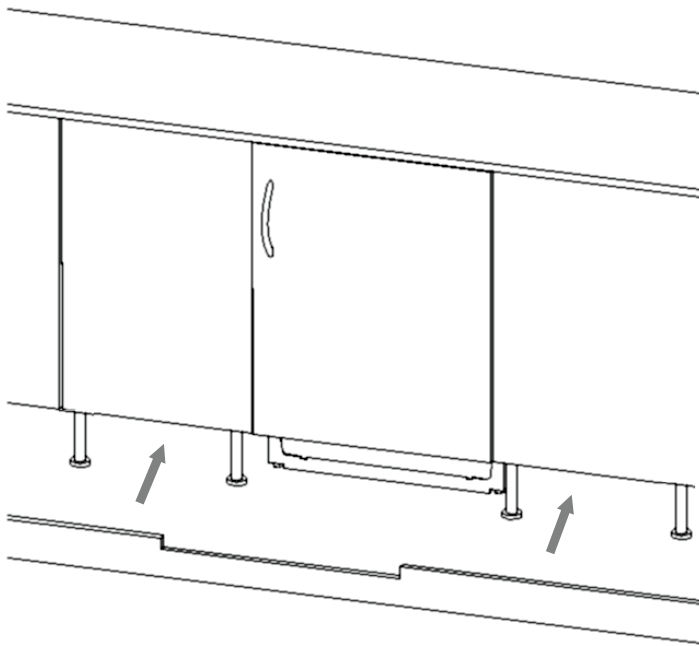

Please keep this instruction manual for future reference

## ELECTRICAL CONNECTION

For your safety please read the following information

### **WARNING: THIS APPLIANCE MUST BE EARTHED.**

This appliance operates from 220-240 volts and should be protected by a 13 amp fuse in the plug.

The appliance is supplied with a standard 13 amp 3-pin mains plug fitted with a 13-amp fuse. Should the fuse require replacement, it must be replaced with a fuse rated at 13 amp and approved to BS1362.

If the mains plug which is fitted is unsuitable for the socket outlet in your home or is removed for any other reason, please follow the instructions below on how to wire a 13 amp 3 pin plug.

### **HOW TO WIRE A 13 AMP PLUG.**

#### **IMPORTANT**

The wires in the mains lead on this appliance are coloured in accordance with the following code:

Green and Yellow - Earth

Blue – Neutral

Brown – Live

As the colours may not correspond with the markings identifying the terminals in your plug proceed as follows.

The green and yellow wire must be connected to the terminal in the plug which is marked with the letter E or with the earth symbol  $\perp$  or coloured green and yellow.

The blue wire must be connected to the terminal marked N.

The brown wire must be connected to the terminal marked L.

You must make sure the lead is firmly secured under the cord clamp.

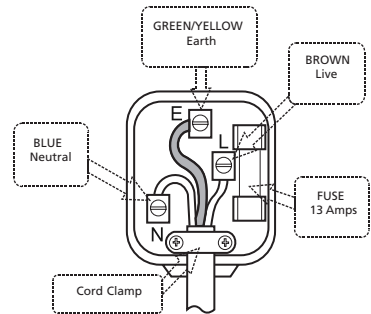

PRODUCT FICHE	RBF4
Product category	8 (Freezer)
Energy class	A+
Annual energy consumption*	177 kWh
Total gross volume	107 l
Total net volume	93 l
Refrigerator gross volume	–
Refrigerator net volume	–
Freezer gross volume	107 l
Freezer net volume	93 l
Star rating	****
Refrigeration system	Static
Temperature rise time (-18°C/-9°C)	1080 minutes
Freezing capacity	9 kg / 24 h
Climate class **	SN (10°C - 32°C)
Noise emission	41 dB (A)

\*Energy consumption of 177 kWh per year, calculated on the basis of results obtained in 24 238 under normalised test conditions. Real energy consumption depends on the conditions in which the equipment is used as well as where it is placed. Real energy consumption depends on the conditions in which the equipment is used as well as where it is placed.

\*\*This appliance is designed for use at an ambient temperature within the 10°C - 32°C range.

Caple Service  
Fourth Way  
Avonmouth  
Bristol  
BS11 8DW

t: 0117 938 7420  
e: [service@caple.co.uk](mailto:service@caple.co.uk)  
[www.caple.co.uk](http://www.caple.co.uk)

Please keep this instruction manual for future reference