



Instruction manual for electric single oven

Model code: C2228SS



Contact Cadle on 0844 800 3830 or for spare parts www.4cadle.co.uk
Read the Instruction manual before your operate the appliance!



Thank you for choosing a Caple oven. With minimal care, as outlined in this guide, your Caple oven is designed to provide you with years of reliable service. This guide will provide you with the information you need to become familiar with your oven's care and operation, and to get the best results.

If you have any questions or comments about this product, please contact your Caple retailer, call 0844 800 3830 , or email info@caple.co.uk. For more information about the complete selection of Caple products, please visit www.caple.co.uk.

▲ WARNING

To reduce the risk of fire, electrical shock, or injury when using your appliance, please follows these basic precautions.

Close up View

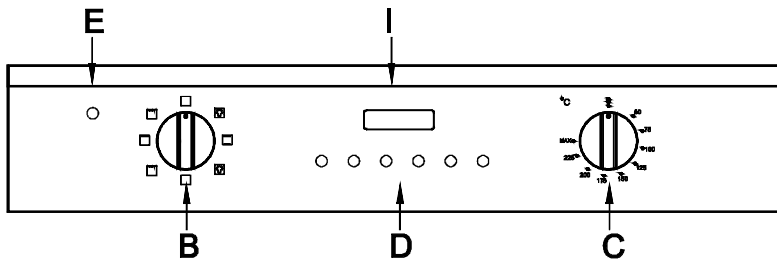
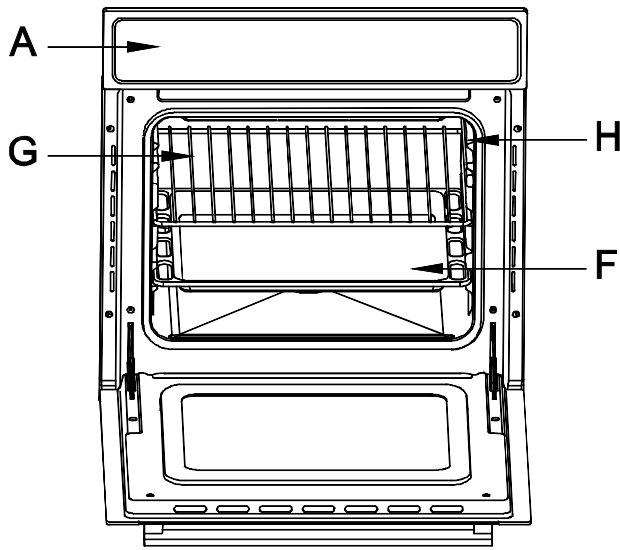

- A. Control panel
- B. Cooking mode selection knob
- C. Cooking temperature selection knob
- D. Push buttons
- E. Oven indicator light (when lit, it indicates the ovens is heating up to the temperature set.)
- F. Dripping pan or baking sheet
- G. Oven Rack
- H. Guides for sliding the racks or dripping pan in and out
- I. Display

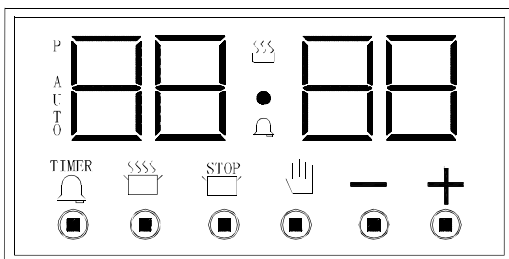





TIMER	minute counter key
SSSS	cooking time key
STOP	end of cooking key
Hand icon	manual operation key
-	minus key
+	plus key
Bell icon	bell symbol
SSSS	Auto work symbol
P	60Hz symbol
AUTO	fully Auto work symbol

Clock & cooking mode adjustment

When using the oven for the first time, or after a power failure, the display flashes regularly and indicates **0:00**. To stop flashing, press key  on the display. By pressing keys **-** or **+** each single press changes the time by 1 minute either up or down. Press one of the two keys until the right time appears.

Semiautomatic cooking



Use this setting for automatic oven switch-off at the end of cooking time. By pressing key  or , the display lights up with "AUTO" symbol, and 4 digits flash ; then, press keys **-** or **+** to set the cooking time.

Release key  or  to start the programmed cooking time count. The display will now show the right time together with symbols **•** and . "AUTO"

Automatic cooking

Use this setting to automatically start and stop the oven.

By pressing key , the display lights up with "AUTO" symbol and 4-digits flash ; then, press keys **-** or **+** to set the cooking time.

By pressing key  the sum of the right time + cooking time will appear; then, press keys **-** or **+** to regulate the end of cooking time, then the display will show the right time together with symbols **•** and . "AUTO"

Adjusting alarm volume

The acoustic alarm has three different settings. These can be operated, while the alarm is sounding, by pressing key **-**.

Switching off the alarm



The alarm switches off automatically after seven minutes. It can be manually turned off by pressing key .

Minute-counter

The programmer can also be used as a simple minute counter.

Warning: The use of the minute-counter will not interrupt oven operation at the end of the set time.



By pressing key , the display shows the bell symbol ; then press keys **-** or **+**. About 5 seconds, the

programmed count starts and the symbols  and  appear on the display.
Notice : After programming the minute-counter, the display will show the right time .



to display remaining time, press key 

Warning: Wrong settings are prevented logically (e.g., any conflict between end of cooking time and a longer cooking time will not be accepted by the programmer).

To cancel a program

Once the program has been set, press the key  or  of the function to be cancelled, and then press **-** or **+** until time **0:00** appeared .Time cancellation will be considered as end-of-cooking time by the programmer.

Changing the program

The cooking data entered can be changed at any time by pressing the function key  or  pressed ,and then adjusting the keys **-** or **+** to the desired time.

How to use your oven

This multi-function oven combines the advantages of traditional convection ovens with those of the more modern fan assisted models in a single appliance.

It is an extremely versatile appliance that allows you to choose easily and safely between 5 different cooking modes. The various features offered by the oven are selected by means of selector knob “B” and the thermostat “C” situated on the control panel.

Note:

This first time you use your appliance, we recommend that you set the thermostat to the highest setting and leave the oven on for about half an hour with nothing in it, with the oven door shut. Then, open the oven door and let the room air in. The odour that is often detected during this initial use is due to the evaporation of substances used to protect the oven during storage and until it is installed.

Note:

Place the dripping pan provided on the bottom shelf of the oven to prevent any sauce and/or grease from dripping onto the bottom of the oven only when grilling food or when using the rotisserie (only available on certain models). For all other types of cooking, never use the bottom shelf and never place anything on the bottom of the oven when it is in operation because this could damage the enamel. Always place your cookware (Dishes, aluminum foil, etc.) on the grid provided with the appliance inserted especially along the oven guides.

Defrost



The fan runs without heat to reduce the defrosting time of frozen foods. The time required to defrost the food will depend on the room temperature, the quantity and type of food.

Conventional mode



Position of the thermostat knob "C": between 50°C and Max. On this setting, the top and bottom heating elements come on. This is the classic, traditional type of oven which has been perfected, with exceptional heat distribution and reduced energy consumption. The convection oven is still unequalled when it comes to cooking dishes made up of several ingredients, e.g. cabbage with ribs, Spanish style cod, Ancona style stockfish, tender veal strips with rice, etc. Excellent results are achieved when preparing veal or beef-based dishes as well (braised meats, stew, goulash, wild game, ham etc.) which need to cook slowly and require basting or the addition of liquid. It nonetheless remains the best system for baking cakes as well as fruit and cooking using covered casserole dishes for oven baking. When cooking in convection mode, only use one dripping pan or cooking rack at a time, otherwise the heat distribution will be uneven. Using the different rack heights available, you can balance the amount of heat between the top and the bottom of the oven. Select from the various rack heights based on whether the dish needs more or less heat from the top.

Fan assisted mode



Position of the thermostat knob "C". Between 50°C and max. The heating elements, as well as the fan, will come on. Since the heat remains constant and uniform throughout the oven, the air cooks and browns food uniformly over its entire surface. With this mode, you can also cook various dishes at the same time, as long as their respective cooking temperatures are the same. A maximum of 2 racks can be used at the same time, following the instructions in the section entitled: "Cooking on More Than one Rack". This fan assisted mode is particularly recommended for dishes requiring a gratin finish or for those requiring considerably prolonged cooking times, such as for example: lasagna, pasta bakes, roast chicken and potatoes, etc...

Moreover, the excellent heat distribution makes it possible to use lower temperatures when cooking roast. This results in less loss of juices, meat which is tender and a decrease in the loss of weight for the roast. The fan assisted mode is especially suited for cooking fish, which can be prepared with a limited amount of condiments, thus maintaining the flavor and appearance.

Desserts: the fan assisted mode is also perfect for baking leavened cakes.

Moreover, this mode can also be used to thaw quickly white or red meat and bread by setting the temperature to 80°C. to thaw more delicate foods, set the thermostat to 60°C or using only the cold air circulation feature by setting the thermostat to 0°C.

"Top" oven



Position of the thermostat knob "C": between 50°C and Max. the top heating element comes on.

This mode can be used to brown food at the end of cooking.

Half Grill



Position of thermostat knob "C": Max.

The top central heating element comes on.

The extremely high and direct temperature of the grill makes it possible to brown the surface of meats and roasts while locking in the juices to keep them tender. The grill is also highly recommended for dishes that require a high temperature on the surface: beef steaks, veal, rib steak, filets, hamburgers etc...

Some grilling examples are included in the "practical cooking advice" paragraph.

Fan assisted Grill



Position of thermostat knob "C": between 50°C and 200°C.

The top central heating element and fan come on. This combination of features increases the effectiveness of the unidirectional thermal radiation of the heating elements through forced circulation of the air throughout the

oven. This helps prevent food from burning on the surface, allowing the heat to penetrate right into the food. Excellent results are achieved with kebabs made with meats and vegetables, sausages, ribs, lamp chops, chicken in a spicy sauce, quail, pork chops, etc.

This mode is also ideal for cooking fish steaks, like swordfish, tuna, grouper, stuffed cuttlefish etc.



Pizza function

Position of thermostat knob "C": between 50°C and max.

This method of cooking uses the lower and circular element while the heat is distributed by the fan reproducing the same conditions of traditional a clay wood-fire stove.



Circular element with fan

Position of thermostat knob "C": between 50°C and max

This method of cooking uses the circular element while the heat is distributed by the fan, resulting in a faster and more economical operation. To allow different kinds of food to be cooked simultaneously on different shelves, preventing the transmission of smells and tastes from one dish onto another.

Timer(D)

When you want to cook food, you have to turn the time clockwise to desired time after setting of cooking modes and temperature, otherwise, the machine will be not energized.

But pls note the timer will count back automatically until "0" position although the power off suddenly, So, you have to set the time again if the food is not cooked well.

°

The oven light



Set knob "B" to symbol  to turn it on. It lights the oven and stays on when any of the electrical heating elements in the oven come on.

Cooling ventilation

In order to cool down the exterior of the appliance, some models are equipped with a cooling fan which comes on automatically when the oven is hot.

When the fan is on, a normal flow of air can be heard existing between the oven door and the control panel.

Note: when cooking is done, the fan stays on until the oven cools down sufficiently. During the cooking period, don't cut off the power.

How to keep your oven in shape

Before cleaning your oven, or performing maintenance, disconnect it from the power supply.

To extend the life of your oven, it must be cleaned frequently, keeping in mind that:

- 1 Do not use steam equipment to clean the appliance.**
- 2 The inside of the oven and stainless steel parts should preferably be cleaned after use, when it is slowly cooled to room temperature, with damp a soft cloth containing soap; then the soap should be wiped away

and the interior dried thoroughly. Avoid using abrasive detergents (for example cleaning powders, etc..) and abrasive sponges for dishes or acids (such as limescale-remover, etc..) as these could damage the enamel and cause stainless steel to get stained. If the grease spots and dirt are particularly tough to remove, use a special product for oven cleaning, following the instructions provided on the packet.

- 3 If you use your oven for an extended period of time, condensation may form. Dry it using a soft cloth.
- 4 There is a rubber seal surrounding the oven opening which guarantees its perfect functioning. Check the condition of this seal on a regular basis. If necessary, clean it and avoid using abrasive products or objects to do so. Should it become damaged, please contact your nearest after-sales service centre. We recommend you avoid using the oven until it has been repaired.
- 5 Never line the oven bottom with aluminium foil, as the consequent accumulation of heat could compromise the cooking and even damage the enamel.
- 6 Clean the glass door using non-abrasive products or sponges and dry it with a soft cloth.
- 7 Do not use harsh abrasive cleaners or sharp metal scrapers to clean the oven door glass since they can scratch the surface, which may result in shattering of the glass.

How to remove the oven door

For a more thorough clean, you can remove the oven door, proceed as follows:

Open the door fully.;

Lift up and turn the small levers both sides on the hinges;

Release the door by pressing down the door catch (please see below for the door catch);

Grip the door on the two external sides; shut it slowly until the levers are against the oven;

Pull the door upward along to take off the door;

Reassemble the door by putting the door back into hinges until the door catch lock up and then lay down the levers in position.

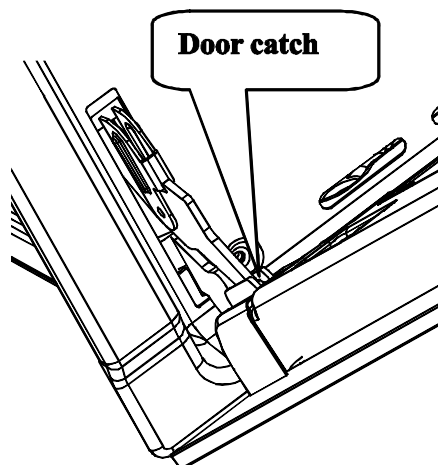
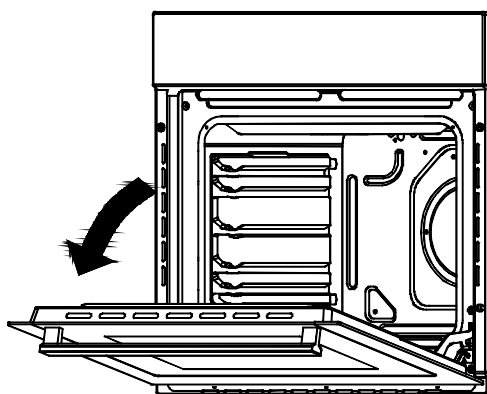

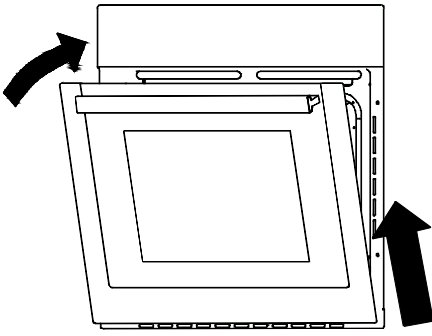

Replacing the oven lamp

- 1 Warning: Ensure that the appliance is switched off before replacing the lamp to avoid the possibility of electric shock
- 2 Remove the glass cover of the lamp-holder;
- 3 Remove the lamp and replace with a lamp resistant to high temperature (300 C) with the following characteristics:

--Voltage:220-240V

--Wattage 25W

--Type T25

--Lamp-holder type: E14

- 4 Screw the glass cover and reconnect the oven to the mains power supply

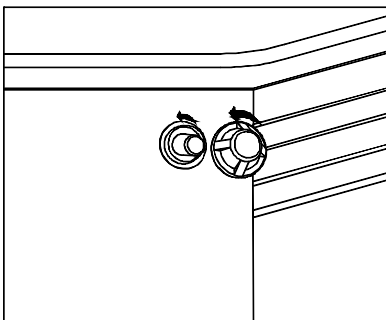

Practical cooking advice

The oven offers a wide range of Functions which allow you to cook any type of food in the best possible way. With time you will learn to make the best use of this versatile cooking appliance and the following directions are only a guideline which may be varied according to your own personal experience.

Preheating

If the oven must be preheated (this is generally the case when cooking leavened foods), the “fan assisted”



mode can be used to reach the desired temperature as quickly as possible in order to save on energy.

Once the food has been placed in the oven, the most appropriate cooking mode can then be selected.

Cooking on more than one rack



If you have to cook on more than on rack at the same time, use only the “fan assisted mode” which is the only one that is appropriate for this type of cooking.

- 1 the oven is fitted with 5 guides. During fan assisted cooking, use two of the three central racks; the lowest and highest racks receive the hot air directly and therefore delicate foodstuffs could be burnt on these racks.
- 2 As a general rule, use the 2nd and 4th rack from the bottom, placing the foodstuffs that require greater heat on the 2nd rack from the bottom. For example, when cooking meat roasts together with other food, place the roast on the 2nd rack from the bottom and the more delicate food on the 4th rack from the bottom.
- 3 When cooking foodstuffs that require different times and temperatures, set a temperature that is somewhere between the two temperature required, place the more delicate food on the 4th rack from the bottom and take the food requiring less time out of the oven first.
- 4 Use the dripping pan on the lower rack and the grid on the upper;

Using the grill

This multi-function oven offers you **2 different grilling modes only and exclusively with oven door shut.**



Use the “grill” mode, placing the food under the centre of the grill (situated on the 3rd or 4th rack from the bottom) because only the central part of the top heating element is turned on.

Use the bottom rack (1st from the bottom), placing the dripping pan provided to collect any sauce and/or grease and prevent the same from dripping onto the oven bottom.

When using this mode, we recommend you set the thermostat to the highest setting. However, this does not mean you can not use lower temperatures, simply by adjusting the thermostat knob to desired temperature.



Setting “fan assisted grill” is extremely useful for grilling foods rapidly, as the distribution of heat makes it possible not only to brown the surface, but also to cook the bottom part.

It can also be used for browning foods at the end of the cooking process, such as adding that gratin finish to pasta bakes, for example.

When using this mode, place the grid on the 2nd or 3rd oven rack from the bottom (see cooking table) then, to prevent fat and grease from dripping onto the bottom of the oven and thus smoke from forming, place a dripping pan on the 1st rack from the bottom.

Important: always use the grill with the oven door shut.

This will allow you both to obtain excellent results and to save on energy (approx 10%).

When using this mode, we advise you to set the thermostat to 200°C, as it is the most efficient way to use the grill, which is based on the use of infrared rays. However, this does not mean you can not use lower temperatures, simply by adjusting the thermostat knob to the desired temperature.

Therefore the best results when using the grill modes are obtained by placing the grid on the lower racks (see cooking table) then, to prevent fat and grease from dripping onto the bottom of the oven and smoke from forming, place a dripping-pan on the 1st oven rack from the bottom.

Baking cakes

When baking cakes, always place them in a preheated oven. Make sure you wait until the oven has been preheated thoroughly (the red light "E" will turn off). Do not open the oven door during baking to prevent the cake from dropping. In general:

Pastry is too dry
Increase the temperature by 10°C and reduce the cooking time

Pastry dropped
Use less liquid or lower the temperature by 10°C

Pastry is too dark on top
Place it on a lower rack, lower the temperature, and increase the cooking time.

Cooked well on the inside but sticky on the outside
Use less liquid, lower the temperature, and increase the cooking time.

The pastry sticks to the pan.
Grease the pan well and sprinkle it with a dusting of flour or use greaseproof paper.

I used more than one level (in the function "ventilated oven") and they are not all at the same cooking point.
Use a lower temperature setting. It is not necessary to remove the food from all the racks at the same time.

Cooking pizza



For best results when cooking pizza, use the "fan assisted" mode.

- 1 Preheat the oven for at least 10 minutes;
- 2 Recommend to Use a light aluminum pizza pan, placing it on the grid supplied with the oven. If the dripping pan is used, this will extend the cooking time, making it difficult to get a crispy crust.

- 3 Do not open the oven door frequently while the pizza is cooking.
- 4 If the pizza has a lot of toppings (three or four), we recommend you add the mozzarella cheese on top halfway through the cooking process.
- 5 When cooking pizza on two racks, use the 2nd and 4th with a temperature of 220°C and place the pizzas in the oven after having preheated it for at least 10 minutes.





Cooking fish and meat



When cooking white meat, fowl and fish, use temperature settings from 180°C to 220°C.

For red meat that should be well done on the outside while tender and juicy in the inside, it is a good idea to start with a high temperature setting (200°C-220°C) for a short time, then turn the oven down for the remaining time.

In general, the larger the roast, the lower the temperature setting, place the meat on the centre of the grid and place the dripping pan beneath it to catch the fat.

Make sure that the grid is inserted so that it is in the centre of the oven. If you would like to increase the amount of heat from below, use the low rack heights. For savory roast (especially duck and wild game), dress the meat with lard or bacon on the top.

Selector knob	Food to be cooked	Weight (in kg)	Cooking rack Position	Preheating time (m)	Thermostat knob setting	Cooking time (m)
1. traditional Convection 	Duck	1	3	15	200	65-75
	Roast veal or beef	1	3	15	200	70-75
	Pork roast	1	3	15	200	70-80
	Biscuits(short pastry)	-	3	15	180	15-20
	Tarts	1	3	15	180	30-35
2. Fan Assisted convection oven 	Pizza (on 2 racks)	1	2-4	15	220	15-20
	Lasagna	1	3	10	200	30-35
	Lamb	1	2	10	180	50-60
	Roast chicken +potatoes	1	2-4	10	180	60-75
	Mackerel	1	2	10	80	30-35
	Plum-cake Cream puffs (on 2 racks)	1	2	10	170	40-50
	Biscuits(on 2 racks)	0.5	2-4	10	180	10-15
	Sponge cake(on 1 rack)	0.5	2	10	170	15-20
	Sponge cake(on 2 racks)	1.0	2-4	10	170	20-25
Savory pies	1.5	3	15	20	25-30	
3. Top oven 	Browning food to perfect cooking	--	3/4	15	220	--
4. Pizza function 	Pizza	0.5	3	15	220	15-20
	Roast veal or beef	1	2	10	220	25-30
	Chicken	1	2 or 3	10	180	60-70
5. Circular element with fan	Tarts	0.5	3	15	180	20-30
	Fruitcakes	1	2 or 3	15	180	40-45
	Plum cake	0.7	3	15	180	40-50
	Sponge cake	0.5	3	15	160	25-30

	Stuffed pancakes (on 2 racks)	1.2	2 and 4	15	200	30-35
	Small cakes(on 2 racks)	0.6	2 and 4	15	190	20-25
	Cheese puffs (on 2 racks)	0.4	2 and 4	15	210	15-20
	cream puffs (on 2 racks)	0.7	1 and 3 and 5	15	180	20-25
	Biscuits (on 3 racks)	0.7	1 and 3 and 5	15	180	20-25
	Meringues (on 3 racks)	0.5	1 and 3 and 5	15	90	180
6. Grill 	Soles and cuttlefish Squid and prawn kebabs	1	4	5	Max	8-10
	Cod filet	1	4	5	Max	10
	Grilled vegetable	1	3/4	5	Max	10-15
	Veal steak	1	4	5	Max	15-20
	Cutlets	1	4	5	Max	15-20
	Hamburgers	1	4	5	Max	7-10
	Mackerels	1	4	5	Max	15-20
	Toasted sandwiches	0.4	4	5	Max	2-3
	With rotisseries(where present)					
	Veal on the spit	1.0	--	5	Max	80-90
	Chicken on the spit	1.5	--	5	Max	70-80
Lamb on the spit	1.0	--	58	Max	70-80	
7. Fan assisted grill 	Grilled chicken	1.5	3	5	200	55-60
	Cuttlefish	1.5	3	5	200	30-35
	With rotisserie(where present)					
	Veal on the spit	1.5	--	5	200	70-80
	Chicken on the spit	2.0	--	5	200	70-80
	Chicken(on the spit) + potatoes(roasted)	1.5	--	5	200	70-75
Lamb on the spit	--	2	5	200	70-75	
	1.5	--	5	200	70-80	

NB: Cooking times are approximate and may vary according to personal taste. When cooking using the grill or fan assisted grill, the dripping pan must always be placed on the 1st oven rack from the bottom.

To maintain the efficiency and safety of this appliance, we recommend that you do the following:

- 1 For any problem, use Caple service;
- 2 Always use original spare parts;
- 3 When handling the appliance, we recommend you always use the purpose provided handles recessed into the sides of the oven to prevent harm or damaging the appliance itself;
- 4 This appliance is designed for non-commercial, house-hold use and its functions must not be changed;
- 5 These instructions are only valid for the countries whose symbols appear on the manual and the serial number plate;
- 6 The electrical system of this appliance can only be used safely when it is correctly connected to an efficient earthing system in compliance with current safety standards;
- 7 This appliance is not intended for use by persons (including children) with reduced physical, sensory or mental capabilities, or lack of experience and knowledge, unless they have been given supervision or instruction concerning use of the appliance by a person responsible for their safety;
- 8 Children should be supervised to ensure that they do not play with the appliance;
- 9 During use the appliance becomes hot. Care should be taken to avoid touching heating elements inside the oven;
- 10 When the appliance is in use, the heating elements and some parts of the oven door become extremely hot. Make sure you don't touch them and keep children well away;

The following items are potentially dangerous, and therefore appropriate measures must be taken to prevent children and disabled from coming into contact with them:

- controls and the appliance in general;
- packaging (bags, polystyrene, nails, etc.);
- the appliance itself, immediately after use of the oven or grill due to the heat generated;
- the appliance itself, when no longer in use (potentially dangerous parts must be made safe).

Avoid the following:

- touching the appliance with wet parts of the body;
- using the appliance when barefoot;
- pulling on the appliance or the supply cable to unplug it from the electrical outlet;
- improper or dangerous operations;
- obstructing the ventilation or heat dissipation slot;
- allowing power supply cables of small appliances to come into contact with the hot parts of the appliance;
- exposing the appliance to atmospheric agents such as rain, or sunlight;
- using the oven for storage purposes;
- using flammable liquids near the appliance;
- using adapters, multiple sockets and/or extension leads;
- attempting to install or repair the appliance without the assistance of qualified personnel.

-WARNING: Accessible parts may become hot during use Young children or infirm persons should be kept away.

Qualified personnel must be contacted in the following cases:

- installation (following the manufacturer's instructions);
- when in doubt about operating the appliances;
- replacing the electrical socket when it is not compatible with the appliance plug.

Service Centres authorized by the manufacturer must be contacted in the following cases:

- If in doubt about the soundness of the appliance after removing it from its packaging;
- if the power supply cable has been damaged or needs to be replaced;
- if the appliance breaks down or functions poorly; ask for original spare parts.

It is a good idea to do the following:

- only use the appliance to cook food and nothing else;
- check the soundness of the appliance after it has been unpacked.
- disconnect the appliance from the electrical mains if it is not functioning properly and before cleaning or performing maintenance.
- when left unused, unplug the appliance from the electricity mains;
- use oven gloves to place cookware in the oven or when removing it.
- Always grip the oven door handle in the centre as the extremities of the same may be not due to any hot air leaks.
- make sure the knobs D and C are in the “●” position when the appliance is not in use.
- after disconnecting it from the mains when you decide not to use the appliance any longer.
- the manufacturer may not be held responsible for any damage due to: incorrect installation, improper, incorrect and irrational use.
- If the power cord is damaged, it must be replaced by the manufacturer or a qualified service engineer to avoid any risks to safety.
- The appliance is for indoor use only.

Installation

The appliance must be installed only by a qualified person in compliance with the instructions provided. The manufacturer declines all responsibility for improper installation which may harm persons and animals and damage property.

Important: the power supply to the appliance must be cut off before any adjustments or maintenance work is done on it.

Installation of built-in ovens

In order to ensure that the built-in appliance functions properly, the cabinet containing it must be appropriate. The figure below gives the dimensions of the cut-out for installation under the counter or in a wall cabinet unit.

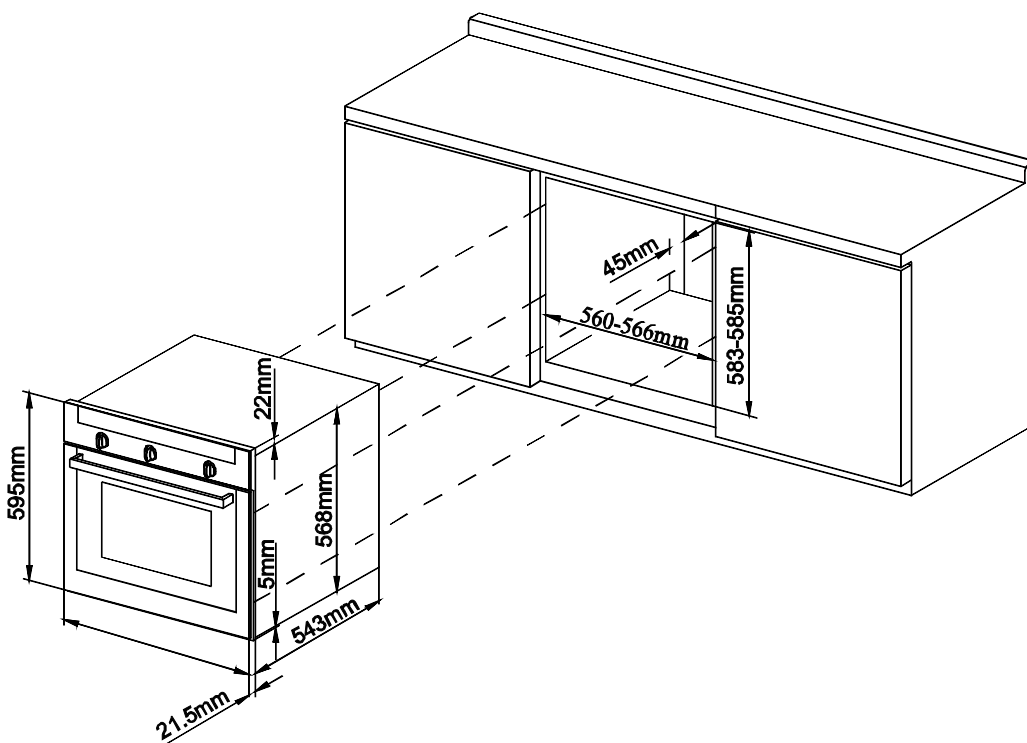

N.B.: Installation in compliance with the consumption declaration

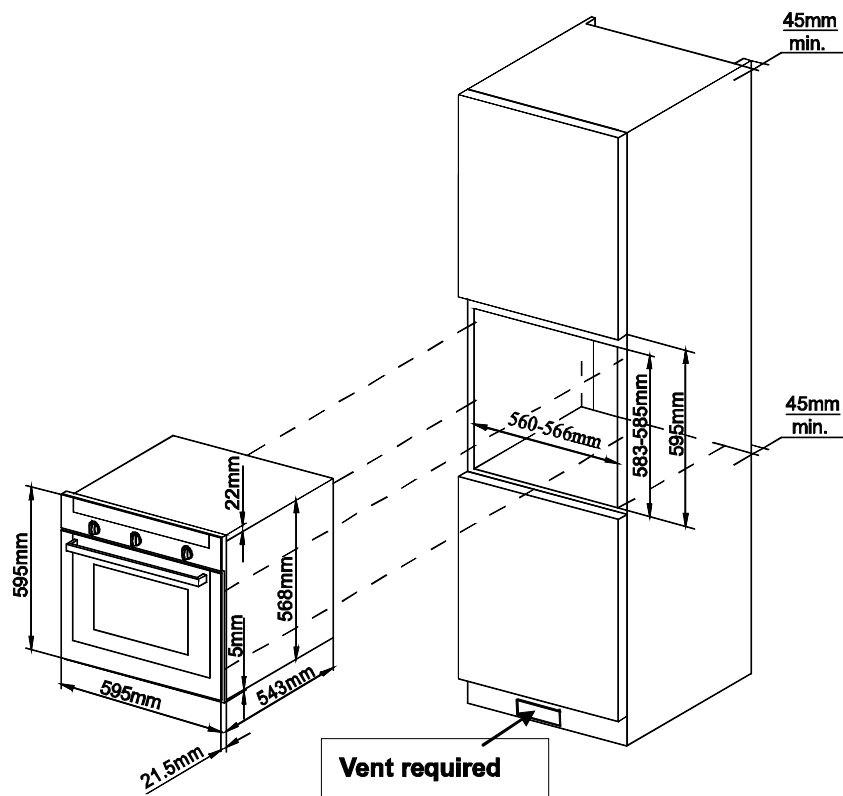

In order to ensure adequate ventilation, the back panel of the cabinet unit must be removed. Installing the oven so that it rests on two strips of wood is preferable. If the oven rests on a continuous, flat surface, there must be an aperture of at least 45x560mm.

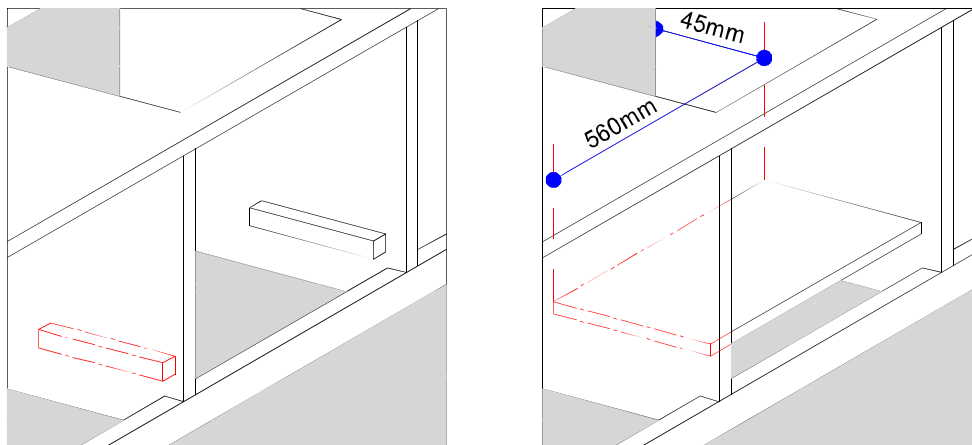

The panels of the adjacent cabinets must be made of heat resistant material. In particular, cabinets with a veneer exterior must be assembled with glues which can withstand temperature of up to 100°C

In compliance with current safety standards, contact with the electrical parts of the oven must not be possible once it has been installed.

All parts which ensure the safe operation of the appliance must be removable only with the aid of a tool.

For the correct centring of your appliance, position the 4 tabs on the sides of the oven in correspondence with 4 holes on the perimeter of the frame. In particular, if the cabinet side panel:

- 1 is 20mm thick: removable part of the tab must be removed (Fig A);

- 2 is 18mm thick: use the first groove, which is factory-set (Fig B)
- 3 is 16mm thick: use the second groove (Fig.C)



<Fig A>

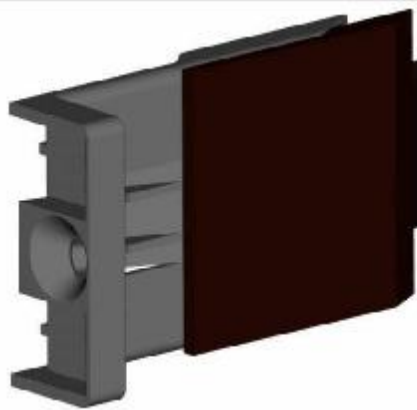

<Fig B>

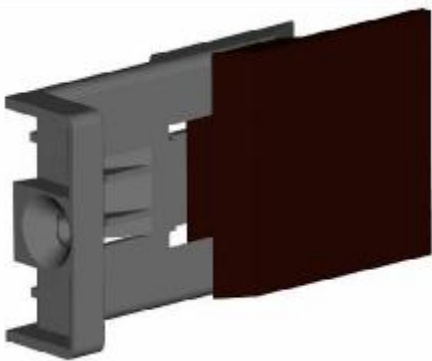

<Fig C>

To fasten the oven to the cabinet, open the door of the oven and attach it by inserting the 4 metal screws into the 4 holes located on the perimeter of the frame.

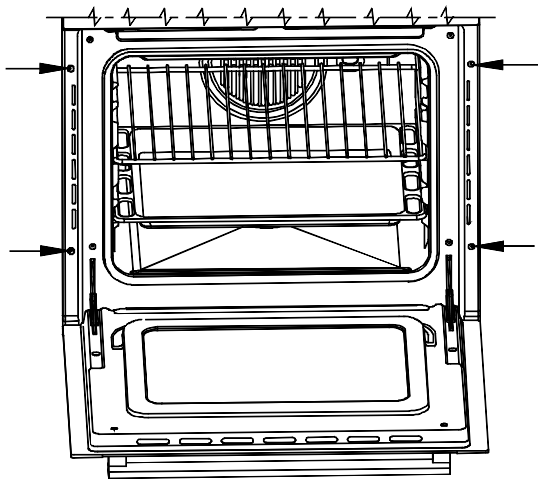

- Do not dispose of electrical appliances as unsorted municipal waste, use separate collection facilities.
- Contact your local government for information regarding the collection systems available.

If electrical appliances are disposed of in landfills or dumps, hazardous substances can leak into the groundwater and get into the food chain, damaging your health and well-being.



Technical specifications.

Inner dimensions of the oven:

Width 43.5cm

Depth 40cm

Height 32cm

Inner volum of the oven

56Liters

Voltage and frequency of power supply:

220-240V~ 50Hz 2250W

(see data plate)



This appliance conforms to the following European Economic Community directives:

-2006/95/EC (Low Voltage) and subsequent modifications;

-2004/108/EC (Electromagnetic Compatibility) and subsequent modifications.

This appliance is marked according to the European directive 2002/96/EC on Waste electrical and Electronic Equipment(WEEE). By ensuring this product is disposed of correctly, you will help prevent potential negative consequences for the environment and human health, which could otherwise be caused by inappropriate waste handling of this product.

The symbol  on the product, or on the documents accompanying the product, indicates that this appliance may not be treated as household waste. Instead it shall be handed over to the applicable collection point for the recycling of electrical and electronic equipment.

Disposal must be carried out in accordance with local environmental regulations for waste disposal.

For more details information about treatment, recovery and recycling of this product, please contact your local city office, your household waste disposal service or the shop where you purchased the product.

