



DD940BK

Caple Downdraft Induction Hob



Technical Manual



DD940BK

Cable Downdraft Induction Hob

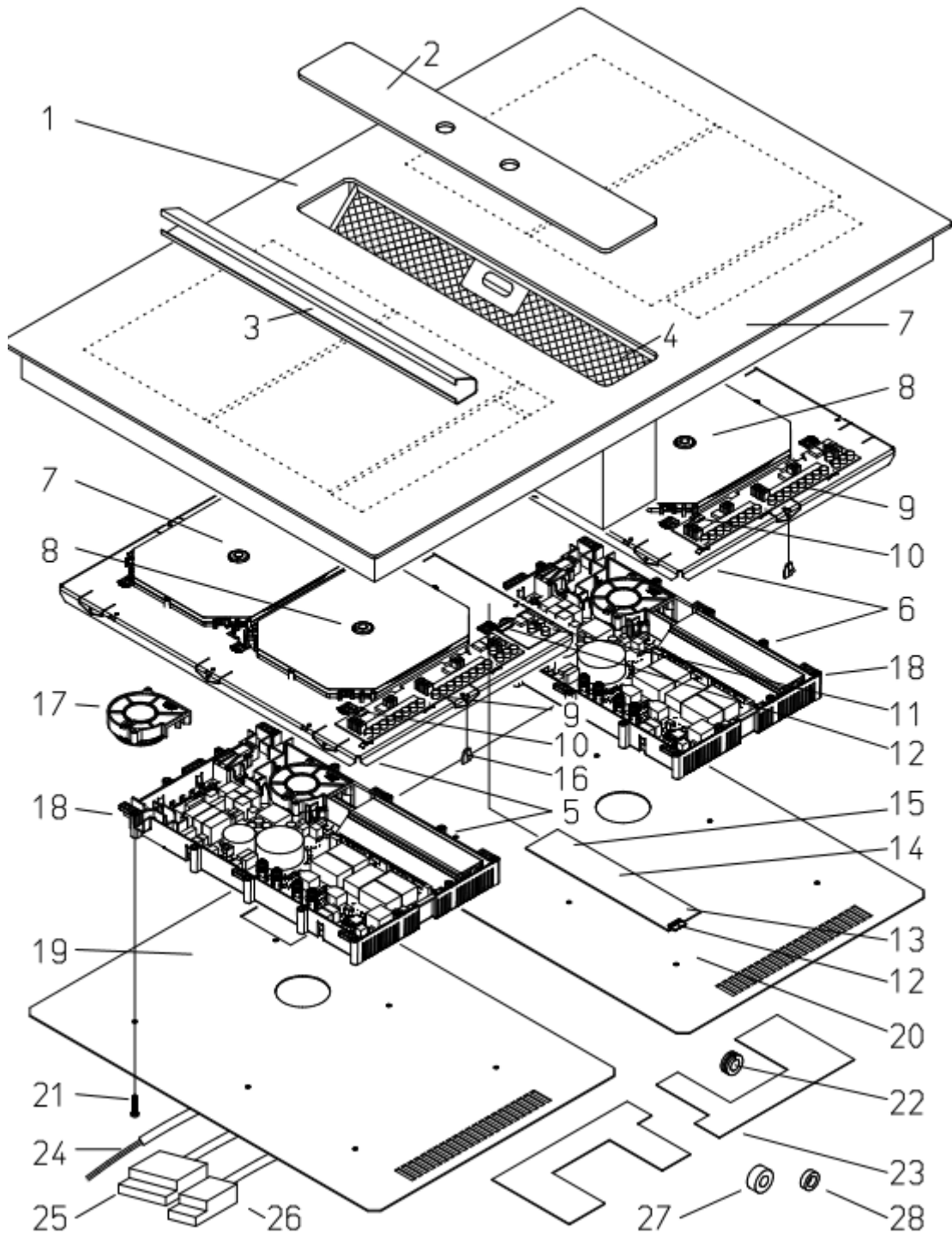



DD940BK

Caple Downdraft Induction Hob

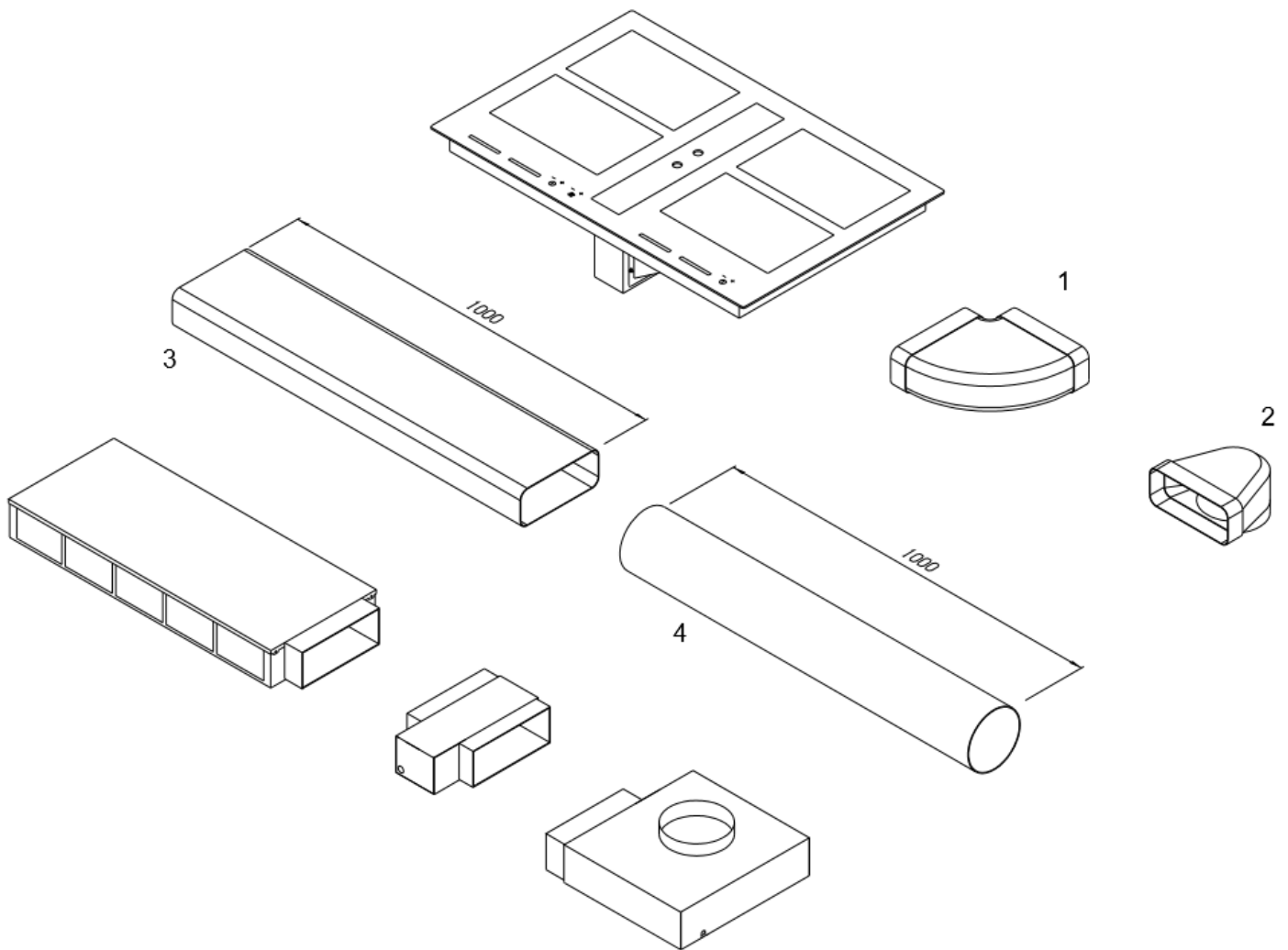



DD940BK

Caple Downdraft Induction Hob

Item	Part Number	Description	Quantity
1	8006216000	Glass	1
2	8006220000	Glass cover	1
3	9500000035	Air leading metal	1
4	9500000034	Filter	1
5	1305402000	Induction G5 IKT 90584 04 flex slider DS	1
6	1305403000	Induction G5 IKT 90584 04 flex slider	1
7	1715260000	Inductor octa (var.1/100mm)	2
8	1715270000	Inductor octa (var.2/100mm)	2
9	1715510000	Touch control flex slider	2
10	1715530000	Lin cable TC	2
11	1407100000	Touch control fan integral	1
12	1806051000	BUS cable 6-pols 150mm	1
13	1407002000	Relay PCB fan/filter integral	1
14	1806031000	Litz wire set IKT 90584 04	1
15	1806033000	Litz wire with plug for induction right side	1
16	1702150000	Grounding clip	2
17	1715030000	Fan	2
18	1715500000	Domino generator	2
19	1206100000	Cover left IKT 90584 04	1
20	1206110000	Cover right IKT 90584 04	1
21	2001450000	Metal plate screw 3,9X25	8
22	1701300000	Rubber sealing	3
23	1206140000	Metal sheet cover IKT 90584 04 two-part	1
24	1801783000	Power supply cord 7GX1,5	1
25	1801780000	Connection cable fan 7GX0,75	1
26	1801781100	Connection cable filter 4GX0,75	1
27	1705140000	Ferrit M-353-01	1
28	1705150000	Ferrit M-607-01	2
	1702300000	Sealing tape	8
Ducting			
1	404.3.003	90° Horizontal duct connection	1
2	404.3.002	90° Horizontal-vertical	1
3	404.3.001	Flat channel	1
4	404.3.010	90cm Round duct pipe	1
Motor			
	GE 225COMP-222	Motor	1

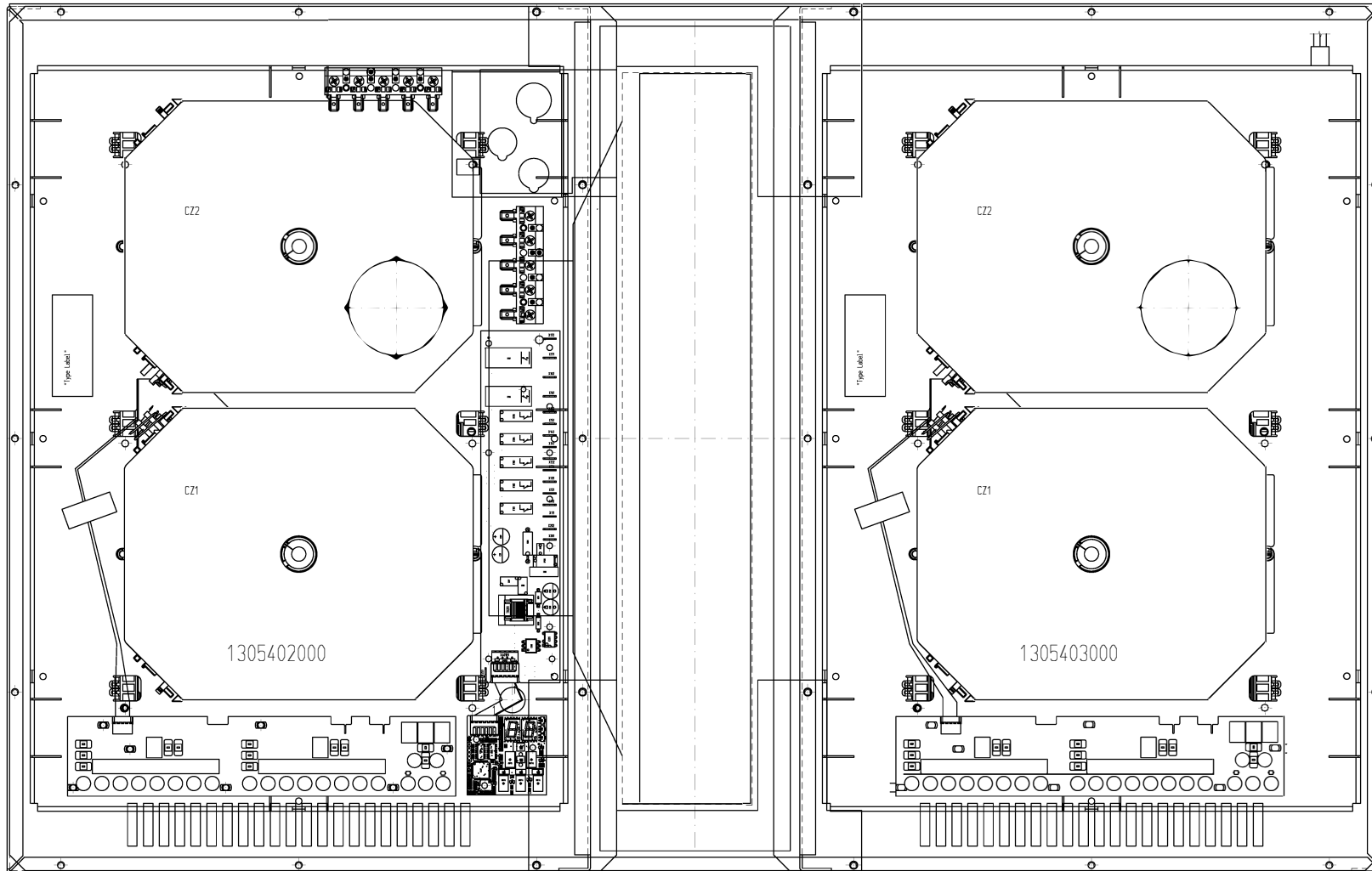

Technical Data one Inductionmodul

Nominal Voltage: 200 - 240 VAC
 Nominal Frequency: 50 / 60 Hz
 Nominal Current: 1 x 16 A

Nominal Wattage at 230 V AC
 Boosterwattage at 230 V AC

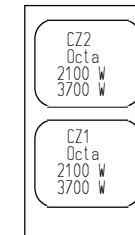

* Coil diameter

Ambient Temperature: 0 - 85 °C
 Approval: VDE

User interface / TC: 75.13106.414

CMOS circuit.
 Pay attention on ESD
 protection.



Mounting Advice

The induction module has to be pressed
 spring-suspended to the glass-ceramic. Full contact of
 the module to the glass-ceramic has to be guaranteed.

Connection

Identifer	Terminal	Connection
CZ1 PB 0/1	X26, X27 X29	Inductor Temp. - Sensor
CZ2 PB 0/0	X24, X25 X26	Inductor Temp. - Sensor
	X32, X33	Interface LIN Stocko MSL0 7230-004-000-960 or equivalent



Access to the Configuration and User Menu for Induction

1. TC Select	75.13X59.XXX and 75.13X60.XXX
2. TC Lite and TC Lite Slider	75.13X37.XXX and 75.13X96.XXX
3. Kit Front TC	75.13X69.XXX and 75.13X70.XXX
4. Kit Domino TC	75.13X68.XXX
5. Flex TC	75.13106.XXX
6. Multislider TC	75.13100.XXX
7. Knob-control (4-fold and 5-fold Ind.)	75.04003.XXX with 75.13X37.XXX
8. Knob-control (2-fold Ind.)	75.04004.XXX
9. Knob-control (Basic 1 Ind.)	75.13X37.XXX
10. Knob-control K6	75.04005.XXX

Access to the menus:

Pre-requirement: The control has to be switched off – possibly existing timer and child lock have to be deactivated.

In order to protect the service menu against unintended user access, the settings are only accessible 2 minutes after reset.

1. TC Select

75.13X59.XXX and 75.13X60.XXX

1.1 Access to User Menu

The special function key (key-lock / pause) has to be actuated and kept pressed. Next, all existing cooktop select keys beginning with the cooktop at the left front have to be actuated one after the other in clockwise direction. Each actuation of a cooktop select key in combination with pressed-down special function key is confirmed with a key sound. The next key has to be pressed within 1s after the last key pressed. When sequence or timing are not met, there is a short double-sound – the access is aborted and the control remains in off-mode.

1.2 Access to Service Menu

If the user menu is also integrated, the access to this menu has to be completed before. Neither a program item nor the respective value must be selected. Directly after access, the further keys for the activation of the service menu have to be pressed. The customer service settings are only accessible within 2 minutes after reset – whether either both menus or only the service menu are integrated in the software.

Plus and minus keys have to be actuated and kept pressed. Next, all existing cooktop select keys, beginning with the cooktop at the right front, have to be actuated one after the other in anti-clockwise direction (opposite to the access to the user menu). Within 1 s after the last key actuation the next key has to be pressed. When the sequence or timing is not followed, there is a short double-sound, the access is aborted and the control remains in off-mode.

1.3 The next step is the customer-specific configuration selection

On the rear left display „C0“ is flashing (configuration menu).

On the front left display you can select the right configuration (“1-9”) for corresponding Induction.

To save the selected configuration go to step 1.4 (save and leave Service menu).

1.4 Save Entries and Leave Service Menu

The service menu may be closed in 3 different ways, but changes are only saved as described in 1.):

1) By actuating the special function key for 2s, all value changes until then are saved and the user menu is closed. The TC signalizes the successful saving with a signal sound and is then in off-mode.

2) Leaving the user menu by pressing the on/off key. Possible changes are not saved, the user menu is closed, the control remains off.

3) The user menu is automatically closed, if there are no entries within 30s. (As from v0.48 within 60s !)
! Changes are not saved. Control is now in off mode. This is acoustically confirmed with a double-sound.

2. TC Lite and TC Lite-Slider

75.13X37.XXX and 75.13X96.XXX

2.1 Access to Configuration Menu

The special function key (key-lock / booster / pause) has to be actuated and kept pressed. Next, all existing cooktop key, beginning with the cooktop at the right front, have to be actuated one after the other in anti-clockwise direction. Each actuation of a cooktop key in combination with pressed special function key is confirmed with a key sound. Within 1s after the last key actuation the next key has to be pressed. When the sequence or timing is not followed, there is a short double-sound, the access is aborted and the control remains in off-mode.

2.2 The next step is the customer-specific configuration selection.

In the TC display for rear left cooking zone “CO” is flashing continuous (Configuration menue).

In the display for front left cooking zone, the selection for the appropriate configuration 1.....9 is possible.

The selection 1....9 has to be done according producers instruction.

The storage of the selected configuration data is specified according to (see 2.3).

2.3 Save Entries and Leave Configuration Menu

The menu may be closed in 3 different ways, but changes are only saved as described in 1):

1) By actuating the on/off key for 2s, all value changes are saved and the configuration menu is closed. The TC signalizes the successful saving with a signal sound; the selected configuration of the induction is transmitted again and realized. Next, the control initiates a reset and is then in off-mode.

2) Leaving the service menu by actuating the special function key. Possible changes are not saved, the menu is closed, the control remains off.

3) The service menu is automatically closed, if there are no entries within 30s. Changes are not saved. Control is then in off-mode.

3. Kit – Front TC

75.13X37.XXX and 75.13X96.XXX

Access to Service Menu

The social function key (key-lock) has to be actuated and kept pressed. For this purpose, three different plus keys of all existing cooktops have to be actuated from right to left. Each actuation of a key in combination with pressed special function key is confirmed with a key sound. Within 1s after the last key actuation, the next key has to be pressed. When the sequence or timing is not followed, there is a short double-sound, the access is aborted and the control remains in off-mode.

The next step is the customer-specific configuration selection.

Save Entries and Leave Service Menu

The menu may be closed in 3 different ways, but changes are only saved as described in 1):

1) By actuating the special function key for 2s, all value changes until then are saved and the service menu is closed. The TC signalizes the successful saving with a signal sound, the selected configuration of the program step 1 of the induction or the multi-circuits is transmitted again and realized. Next, the control initiates a reset and is then in off-mode.

2) Closing the service menu by actuating the on/off key. Possible changes are **not** saved, the menu is closed, the control remains off.

3) The service menu is automatically closed, if there is no entry within 30s. (As from v0.25 within 60s !)
Changes are **not** saved. Control is then in off-mode. This is acoustically signalized with a double-sound.

Access to User Menu

The access to the user menu is similar to the access to the service menu: here, also the special function key (key lock) has to be actuated and kept pressed. For this purpose, three different minus keys of the existing cooktops have to be actuated one after the other from left to right. The access to the menu is independent from the service menu (one menu does not require reaching the other menu), also only in off-mode, without timer set, independent from error messages. However, the user menu is not limited to 2 minutes after reset, the access is possible anytime.



4. Kit – Domino TC

75.13X68.XXX

Access to Service Menu

The special function key (key-lock / pause) has to be actuated and kept pressed. For this purpose, the first three keys of the control have to be actuated from left to right. Usually, these are the keys assigned on the left of the cooktop – special function, minus and plus. If the cooktop on the left is not

existing, the keys of the cooktop on the right are used for access. Each actuation of a key in combination with pressed special function key is confirmed with a key sound. Within 1s after the last key actuation, the next key has to be pressed. When the sequence or timing is not followed, there is a short double-sound, the access is interrupted and the control remains in off-mode.

The next step is the customer-specific configuration selection.

Save Entries and Leave Service Menu

The menu may be closed in 3 different ways, but changes are only saved as described in 1):

1) By actuating the special function keys for 2s, all value changes until then are confirmed and the service menu is closed. The TC signalizes the successful saving with a signal sound, the selected configuration of program step 1 of the induction or the multi-circuits is transmitted again and realized. Next, the control initiates a reset and is then in off-mode.

2) Closing the service menu by actuating the on/off mode: Possible changes are **not** saved, the menu is closed, the control remains off.

3) The service menu is automatically closed, if there are no entries within 60s. Changes are **not** saved. Control is in off-mode. This is acoustically confirmed with a double-sound.

5. Flex TC

75.13106.XXX

Access to Service Menu

In the first step, the two special function keys have to be actuated and kept pressed for 4s. In the second step, the two sliders on the master TC have to be actuated and kept pressed for 4s.

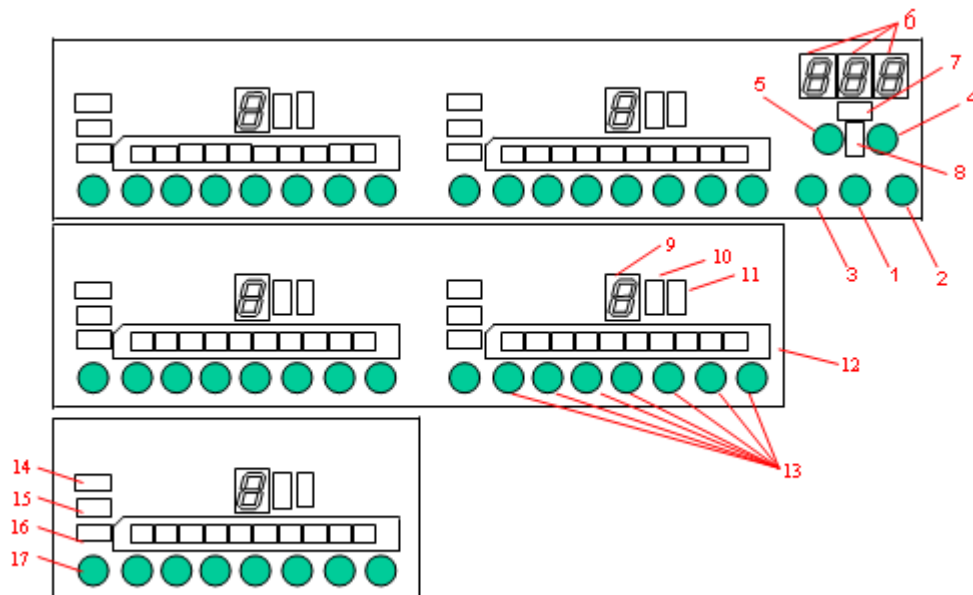

- 1) Power key with assigned LED (optional)
- 2) Special function key 1 with LED
- 3) Special function key 2 with LED
- 4) Timer key 2
- 5) Timer key 1
- 6) 3 digit timerdisplay
- 7) Timer luminous cap 1
- 8) Timer luminous cap 2
- 9) Multi-functional display per cooking zone
- 10) cooking zone related luminous cap 1 (i.e. booster, timer, outer coil)
- 11) cooking zone related luminous cap 2 (i.e. booster, timer, outer coil)
- 12) cooking zone related bargraph
- 13) cooking zone related Sliderinterface
- 14 – 16) cooking zone related special function (i.e. automatic mode)
- 17) cooking zone related select key for special functions

The next step is the customer-specific configuration selection.

Save Entries and Leave Service Menu

In order to take over the settings on all TCs, the two special function keys have to be actuated both for 1 s. This is followed by a reset and a re-configuration of the connected induction modules.

In order to close the menu without taking over the changed settings and without re-configuration, the main switch key has to be actuated.

6.Multislider TC

75.13100.XXX

Access to Service Menu

The special function key has to be actuated and kept pressed. For this purpose, three different sliders (position not important) of all existing cooktops have to be actuated from right to left. Each actuation of a key in combination with pressed special function key 1 is confirmed with a key sound. 1s after the last key actuation the next key has to be pressed. When the sequence or timing is not followed, there is a short double-sound, the access is aborted and the control remains in off-mode.

The next step is the customer-specific configuration selection.

Save Entries and Leave Service Menu

The menu may be closed in 3 different ways, but changes are only saved as described in 1):

1) The actuation of the special function key for 2s saves all value changes until then and the service menu is closed. The TC signalizes the successful saving with a signal sound – the selected configuration in program step 1 of the induction or the multi-circuits is transmitted again and realized. Next, the control initiates a reset and is then in off-mode.

2) Leaving the service menu by actuating the on/off key. Possible changes are **not** saved, the menu is closed, the control remains off.

3) The service menu is automatically closed, if there are no entries within 60s. Possible changes are **not** saved. Control is then in off-mode. This is acoustically conformed with a double-sound.

Access to User Menu

The access to the user menu is similar to the access to the service menu: here, also the special function key 1 has to be actuated and kept pressed. For this purpose, three different sliders (position not important) of the existing cooktops have to be actuated from left to right one after the other. The access to the menu is independent from the service menu (one menu does not require reaching the other menu), also only in off-mode, without set timers, independent from error messages. However, the user menu is not limited to 2 minutes after reset, the access is possible any time.

7. Knob-control (Ind. G4 4-fold and 5-fold Ind.)

75.04003.XXX and 75.13X37.XXX

The service menu allows the selection of various configurations or starting the configuration download manually.

In order to get to the service menu, knob #1 is overwound to the left ('A') and, at the same time, knob #2 is overwound three times to the right ('P'). Five seconds are provided for this without breaking off the intro. One can only get to the service menu 2 minutes after resetting the control unit e.g. after feeding mains voltage into the induction cavity.

The display alternates flashing between 'C' and '0'. After overwinding to the right, knob #2 is in max. position. Knob #1 may now serve to select the desired configuration (0..7). This is indicated via alternating flashing the 'C'. Once the correct configuration is selected, knob # 2 is turned back to 0. Now the configuration may no longer be altered via knob #1.

If a download of the configuration to the induction is really wanted, knob #1 first needs to be set into 'A' to be followed by knob #2. To be able to cancel the service menu without any new configuration, knob #2 may be set into "A" on its own any time. After this, the control unit carries out a reset.

8. Knob-control (Ind. G4 2-fold)

75.04004.XXX

ATTENTION!

This sequence has to be operated within 5 seconds without interruption. The service menu is only accessible for the first 2 minutes after reset of the control system (that is after connection to the power supply for the first time).

1. To enter the service menu overwind the right knob (X1) during 5 sec. 4 times into the left direction, at the fifth time hold it until "C" and "1-9" at the display appears.
2. To delete the actual configuration overwind the right knob (X1) clockwise and turn it back to "0" -> display shows "C0".
3. Then turn knob (X1) to the right, till the required configuration ("C1-C9") is shown at display and turn the knob back to "0".
4. To save the configuration overwind the knob (X1) to the left and hold it for 5 sec.

Remark:

If child lock "L" at the display appears -> overwind both knobs to the left until "L" disappears.

9. Knob-control (Basic 1 Ind.)

ATTENTION!

This sequence has to be operated within 5 seconds without interruption. The service menu is only accessible for the first 2 minutes after reset of the control system (that is after connection to the power supply for the first time).

1. To activate the service menu knob-L (X1) needs to be turned into the left overwind position and hold it in this position until the end of the 2nd step. (display shows "A")
2. Then overwind knob-R (X4) three time into right direction.
3. By successful enter the display shows "C"
4. Unhand both knobs.
5. Turn knob-R (X4) to "0"
6. Turn knob-L (X1) to "9" -> deletion of IHE configs.
7. Turn knob-L (X1) back to "0" -> display shows "C1"
8. Put an induction qualified cooktop to the front left cooking zone till "C2" at display appears.
9. Put an induction qualified cooktop to the rear left cooking zone till "C3" at display appears.
10. Put an induction qualified cooktop to the rear right cooking zone till "C4" at display appears.
11. Put an induction qualified cooktop to the front right cooking zone till "C4" at display disappears.
12. After successful configuration of all cooking zones the configurations menu will end automatically

10. Knob-control "K6"

75.04005.XXX

The service menu allows the selection of various configurations or starting the configuration download manually!

„Knob-L“ is always the knob connected to the position X3 (rear right) of the splitter board and „knob-R“ is the knob connected to the position X4 (front right) of the splitter board.

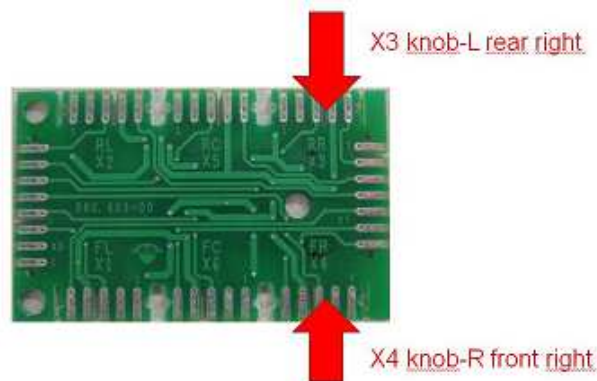

ATTENTION!

This sequence has to be operated within 5 seconds without interruption. The service menu is only accessible for the first 2 minutes after reset of the control system (that is after connection to the power supply for the first time).

To activate the service menu knob-L needs to be turned into the left overwind position the display shows „A“.

While holding the knob-L in this position turn knob-R into overwind right position display shows „P“ and hold for 1 sec until display „P“ disappear, then let the knob turn back to maximum level (typically display „9“) repeat this 3 times and during the third repeat let both knobs turn back (knob-R to maximum level typically display „9“ and knob-L to position „0“).

If the service menu gets activated the display unit will toggle between showing „C“ and „0“. Knob-R has come back to the maximum power level after overwinding to the right. Turning knob-L clockwise the required configuration (0..9) can be selected. The actual configuration is displayed on the display unit alternating with „C“. If the correct configuration is selected turn knob-R back to the zero position. Now the configuration can not be changed anymore turning knob-L back to the zero position.

To activate the download of the selected configuration now turn knob-L and knob-R into the left overwind position and hold both for 1 second.

To quit the service menu without changing the configuration turn the knob-R on the left overwind position („A“) at any time. The control unit then does a reset.

Error Report TC – Display for Ind G5

Legend:



visual check



Decisions have to be realized step by step.





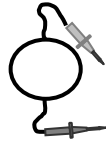



no measurement required or not worthwhile realizable





Measurement with multimeter



The following step only has to be Executed, if the previous one was not successful.

Error code	Description	Possible reason for failure	Measure	Decision
 Er03	Cont. key activation, Control switches off after 10s.	Liquid or cookware on glass above control		⇒ clean glass ceramics
U400	Wrong connection	Input voltage >300V		⇒ inspection mains connection ⇒ replace filter (incl. internal wiring) ⇒ replace power unit
Er20	Flash error Data not plausible Flash Rom check sum wrong Programming options wrong	Component part error Touch control Transmission of wrong configuration data Configuration data not plausible		⇒ replace touch control ⇒ programming of the correct configuration data (see customer service menu)

Error code	Description	Possible reason for failure	Measure	Decision
Er22	Key evaluation defect Touch control switches off after 3.5-7.5s.	Short circuit or interruption near the key evaluation	✕	⇒ replace touch control
Er31	Configuration data wrong TC assignment to induction series wrong No or partial functions	Automatic configuration of filter boards caused by wrong TC type Component part error on TC or filter board		⇒ check, if correct TC type was used ⇒ activate configuration of TC with service menu and start download ⇒ replace TC cable ⇒ replace power unit.
Er47	Communication error between TC und induction	Configuration error One induction generator without voltage (hobs with multiple generators) TC defect TC cable not correctly plugged on or defect Power unit defect		⇒ activate configuration of TC with service menu and start download ⇒ check mains voltage ⇒ check TC cable reg. tight seat ⇒ replace TC and TC cable ⇒ replace power unit ⇒ replace filter

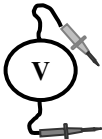
Error code	Description	Possible reason for failure	Measure	Decision
EA	Cooling body temperature sensor not plausible One control pulse recognized on switched-off cooktop AD converter defect	Component part error on power unit		⇒ replace power unit ⇒ replace TC
E 2	Over-temperature cooktop Fixed sensor test Coilsensor Failure algorithm recompute (only powerlevel 9)	cooktop overheated (cooking with empty pan) Return heat on coil sensors > switch-off threshold In case of no temperature change after 5 minutes activation on a cookingzone, the failure code "E2" will be displayed in the TC		⇒ cooling down of cooktop required Error display disappears after cooling down. ⇒ replace inductor with sensor ⇒ replace power unit
E 4	Configuration not plausible	Configuration check sum not plausible		⇒ re-configure generator ⇒ replace touch control ⇒ replace power unit

Error code	Description	Possible reason for failure	Measure	Decision
E 6	<p>Voltage supply</p> <p>Power unit</p> <p>cable</p> <p>Filter board</p>	<p>Check safety PCB tracks on filter board</p> <p>Power unit defect</p> <p>Picoflex or tube not correctly plugged on or cable defect</p> <p>Filter board defect</p>		<p>⇒ Check safety PCB tracks F100 /F101</p> <p>Safety PCB track burnt through</p> <p>⇒ inspection of all IGBT reg. short circuit</p> <p>⇒ in case of short circuit; replacement of power unit</p> <p>⇒ insert included 20 A safety fuse into fuse holder on filter</p> <p>Note: If the safety PCB track is not activated in case of short circuit, the filter has to be replaced!</p> <p>Safety PCB track not burnt through</p> <p>⇒ check mains voltage</p> <p>⇒ check cable and tube</p> <p>⇒ replace filter board</p>

Error code	Description	Possible reason for failure	Measure	Decision
E 8	Fan rotation too quick or too slow	covered air intake fan defect Component part error		⇒ check air supply ⇒ replace fan ⇒ replace power unit ⇒ replace filter
E 9	PT sensor mechanically or electrically defect	Mechanic rupture of PT sensor Resistance value drifting off Power unit defect	 approx. 47kΩ	⇒ replace inductor with sensor ⇒ replace power unit

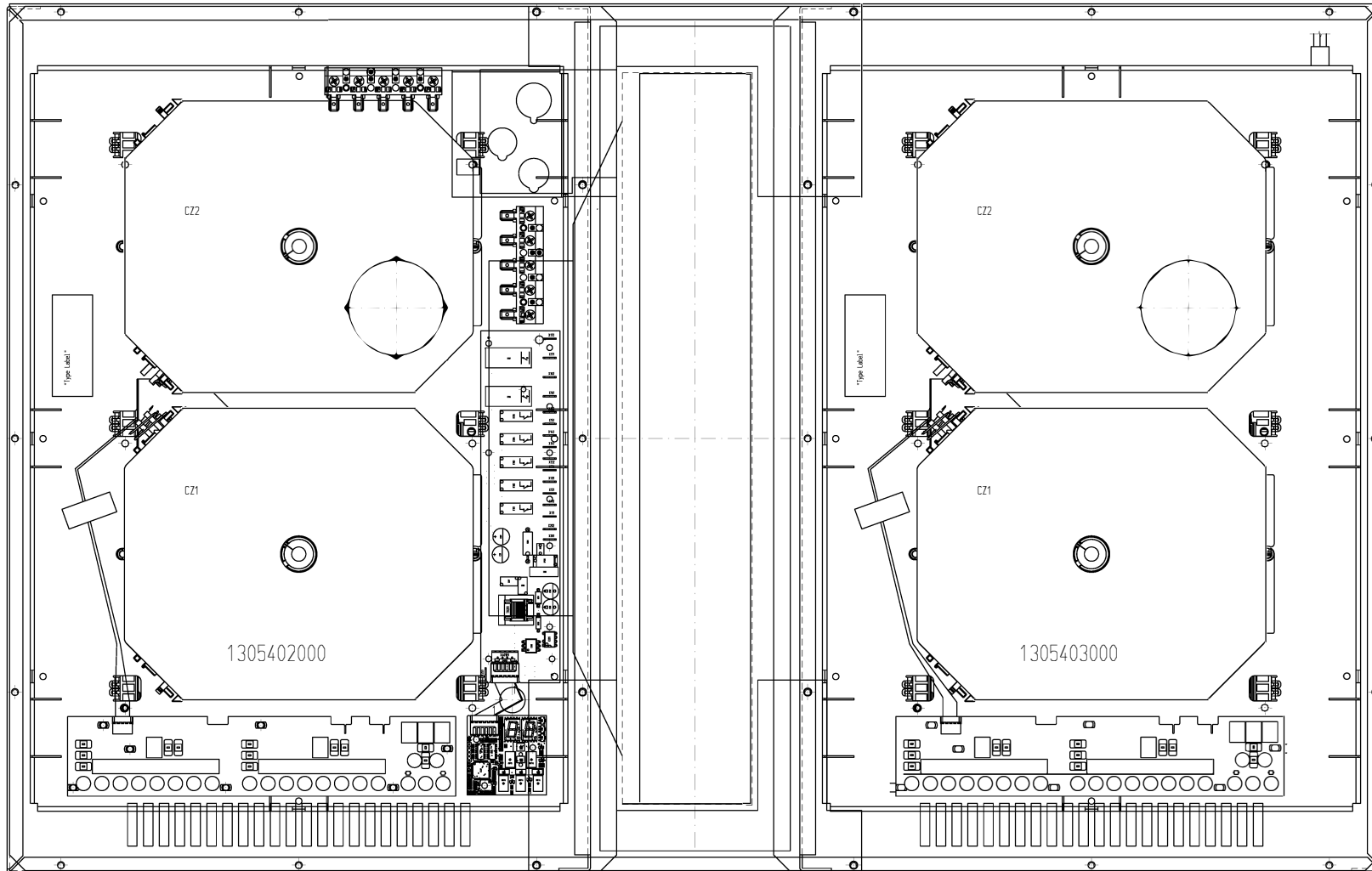

Technical Data one Inductionmodul

Nominal Voltage: 200 - 240 VAC
 Nominal Frequency: 50 / 60 Hz
 Nominal Current: 1 x 16 A

Nominal Wattage at 230 V AC
 Boosterwattage at 230 V AC

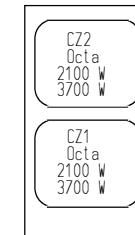

* Coil diameter

Ambient Temperature: 0 - 85 °C
 Approval: VDE

User interface / TC: 75.13106.414

CMOS circuit.
 Pay attention on ESD
 protection.



Mounting Advice

The induction module has to be pressed
 spring-suspended to the glass-ceramic. Full contact of
 the module to the glass-ceramic has to be guaranteed.

Connection

Identifer	Terminal	Connection
CZ1 PB 0/1	X26, X27 X29	Inductor Temp. - Sensor
CZ2 PB 0/0	X24, X25 X26	Inductor Temp. - Sensor
	X32, X33	Interface LIN Stocko MSL0 7230-004-000-960 or equivalent

