



# Induction Downdraft Extractor Instruction Manual

# DD940BK



Contact Caple on 0117 938 7420 for spare parts or [www.caple.co.uk](http://www.caple.co.uk)

## CONTENTS

---

Introduction	3
Safety Instructions	4
Appliance Description	12
Operating the Hob	13
Operating the Downdraft	31
Care and Maintenance	33
Troubleshooting	35
Installation	39
Installation of the Plinth Motor	47
Plasma Filtration	51
After Sales	53
Caple Contact Details	56

# INTRODUCTION

Thank you for choosing this Caple induction downdraft extractor.

To ensure that you get the best results from your new induction downdraft extractor, we strongly suggest that you read this instruction manual thoroughly before use. If treated with care, your Caple product should give you years of trouble-free use.

To register ownership, please ensure you complete and return the guarantee card supplied with the appliance or visit [www.caple.co.uk](http://www.caple.co.uk) and register here.

This instruction manual is designed to provide you with all the required information related to the installation, use and maintenance of the appliance.

This induction downdraft extractor is designed to extract unpleasant odours and cooking vapours from the kitchen. In order to operate the unit correctly and safely, please read this instruction manual carefully before installation and use.

Please read this manual carefully before using your appliance. It contains important safety advice; it explains how to use and look after your appliance so that it will provide you with many years of reliable service.

Should a fault arise, please first consult the "Troubleshooting" section. You can often rectify minor problems yourself, thus saving unnecessary service costs.

Please keep this manual in a safe place and pass it on to new owners for their information and safety.

## **SAFETY INSTRUCTIONS AND WARNINGS:**

- The appliances are constructed in accordance with the relevant safety regulations.
- Connecting the appliances to the mains and repairing and servicing the appliances may only be carried out by a qualified electrician according to currently-valid safety regulations. For your own safety, do not allow anyone other than a qualified service technician to install, service or repair the product.
- If the mains cable of this appliance is damaged, it has to be replaced by the manufacturer, the Customer Service Department of the manufacturer or by another qualified person to avoid danger.
- The appliance may not be operated with an external timer or an external telecontrol system.

## **GENERAL INFORMATION ON THE HOB:**

- Never allow the induction hob to operate unattended, as the high power setting results in extremely fast reactions.
- When cooking, pay attention to the heat-up speed of the cooking zones. Avoid boiling the pans dry as there is a risk of the pans overheating.
- Do not place empty pots and pans on cooking zones which have been switched on.
- Take care when using simmering pans as simmering water may dry up unnoticed, resulting in damage to the pan and to the hob for which no liability will be assumed.
- It is essential that after using a cooking zone you switch it off with the respective minus key and not just with the pan recognition device.
- Overheated fats and oils may spontaneously ignite. Always supervise the preparation of food with fats and oils. Never extinguish ignited fats and oils with water. Switch the appliance off and then carefully cover the flame, for example with a lid or an extinguisher blanket.
- The glass ceramic surface of the hob is extremely robust. You should, however, avoid dropping hard objects onto the glass ceramic hob. Sharp objects which fall onto your hob might break it.

- There is a risk of electric shock if the glass ceramic hob develops fractures, cracks, tears or damage of any other kind. Immediately switch off the appliance. Disconnect the fuse immediately and call Caple Service.
- If the hob cannot be switched off due to a defect in the sensor control, immediately disconnect your appliance and call Caple Service.
- Take care when working with home appliances. Connecting cables must not come into contact with hot cooking zones.
- Risk of fire: never store items on the hob.
- The glass ceramic hob should not be used as a storage area.
- Do not put aluminium foil or plastic onto the cooking zones. Keep everything which could melt, such as plastics, foil and in particular sugar and sugary foods away from hot cooking zones. Use a special glass scraper to immediately remove any sugar from the ceramic hob (when it is still hot) in order to avoid damaging the hob.
- Metal items (pots and pans, cutlery, etc.) must never be put down on the induction hob since they may become hot. Risk of burning.
- Do not place combustible, inflammable or heat deformable objects directly underneath the hob.

- Metal items worn on your body may become hot in the immediate vicinity of the induction hob. Caution: Risk of burns. Non-magnetisable objects (e.g. gold or silver rings) are not affected.
- Never use the cooking zones to heat up unopened tins of food or packaging made of material compounds. The power supply may cause them to burst.
- Keep the sensor keys clean since the appliance may consider dirt to be finger contact. Never put anything (pans, tea towels etc.) onto the sensor keys. If food boils over onto the sensor keys, we advise you to activate the OFF key.
- Hot pans should not cover the sensor keys, since this will cause the appliance to switch off automatically.
- Whenever possible, use the back cooking zones for large pans so that the sensor keys are not heated up too much (touch control overheating; error message E2).
- Activate the childproof lock if there are any pets in the home which could make contact with the hob.
- Never clean the glass ceramic hob with a steam cleaner or similar appliance.
- Make sure there are no items (e.g. cleaning cloths) right next to the hob extractor. They could be sucked in by the air current. Liquids and small items must always be kept away from the appliance.

- Do not operate the appliance without grease filters fitted.
- Grease filters with too much fat deposits are a fire hazard.
- Constant supervision is essential when deep-frying; flambéing is not permitted.
- A sufficient supply of inlet air must be provided when operating wood, coal, gas or oil heaters requiring a chimney. The permissible negative pressure which results from the hood in the location of the heaters requiring a chimney may not exceed 4 Pa (0.04 mbar) as this results in a risk of poisoning.
- Vapour also emits moisture into the air in the kitchen during the cooking process.
- Only a little moisture is removed from the vapours in the convection air mode. This is why a sufficient supply of fresh air must always be provided, e.g. by opening the window or using a domestic ventilation systems.
- Always make sure that the indoor climate is normal and comfortable (45 - 60 % humidity).
- Switch the hob extractor down to a lower setting for around 20 minutes or activate the automatic delayed stop function every time the hob extractor is used in the convection air mode.

## **WARNINGS:**

- These appliances may be used by children aged 8 years and over and by persons with physical, sensory or mental impairments or by persons who lack experience and/or know-how, provided they are supervised or have been instructed in the safe use of the appliance and have understood the risks relating to the appliance. Children may not play with the appliance. Cleaning and maintenance by the user may only be carried out by children when they are supervised.
- The surfaces of the heating and cooking zones become hot during use. Keep small children away at all times.
- Only hob protective grids and hob covers produced or recommended by the hob manufacturer or recommended may be used. The use of unsuitable hob protective grids and hob covers may result in accidents.
- Persons with cardiac pacemakers or implanted insulin pumps must make sure that their implants are not affected by the induction hob (the frequency range of the induction hob is 20-50 kHz).

## **APPROPRIATE USE:**

- This appliance is intended to be used in household and similar applications such as:
  - › Staff kitchen areas in shops, offices and other working environments.
  - › Farm Houses.
  - › By clients in hotels, motels and other residential type environments.
  - › Bed and breakfast type environments.



## ENVIRONMENTAL PROTECTION

Waste electrical products should not be disposed of with household waste. Please recycle where facilities exist. Check with your Local Authority or retailer for recycling advice. This appliance is marked according to the European directive on Waste Electrical and Electronic Equipment (WEEE).

By ensuring this product is disposed of correctly, you will help prevent potential negative consequences for the environment and human health, which could otherwise be caused by inappropriate waste handling of this product. The symbol on the product indicates that this product may not be treated as household waste. Instead it shall be handed over to the applicable collection point for the recycling of electrical and electronic equipment. Disposal must be carried out in accordance with local environmental regulations for waste disposal.

For more detailed information about treatment, recovery and recycling of this product, please contact your local council, your household waste disposal service or the retailer where you purchased the product.

## WARRANTY

Your new appliance is covered by warranty. The warranty card is enclosed - if it is missing, you must provide the following information to your retailer in order to receive a replacement: date of purchase, model and serial number. Registration can also be completed online by visiting [www.caple.co.uk](http://www.caple.co.uk).

Ensure you keep your warranty card safe, you may need to show it to Caple Service together with proof of purchase. If you fail to show your warranty card you will incur all repair charges.

Spare parts are only available from Caple Service and spare parts authorised centres.

## CE DECLARATIONS OF CONFORMITY



This appliance has been manufactured to the strictest standards and complies with all applicable legislation, Low Voltage Directive (LVD) and Electromagnetic Compatibility (EMC).

## UKCA DECLARATIONS OF CONFORMITY



This appliance has been manufactured to the strictest standards and complies with all applicable legislation.

## TECHNICAL FICHE

This appliance conforms to all current and applicable energy regulations. To view the Technical Fiche that supports the energy labelling data, please visit the product page on our website [www.caple.co.uk](http://www.caple.co.uk).

# APPLIANCE DESCRIPTION

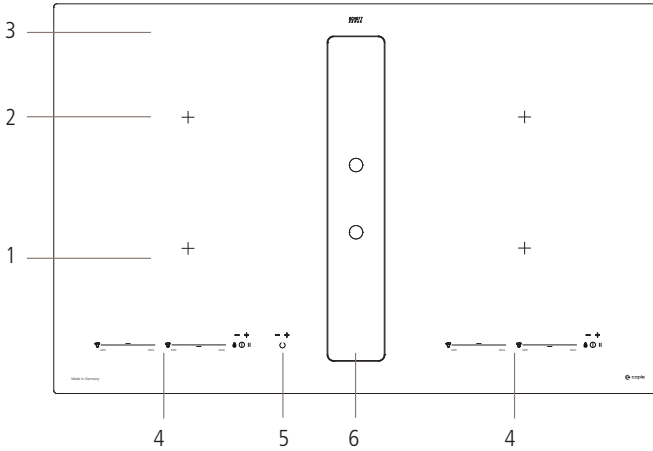

- 1. Induction cooking zone front
- 2. Induction cooking zone back
- 3. Glass ceramic surface
- 4. Touch-control operating panel for hob
- 5. Standby key and downdraft control
- 6. Downdraft

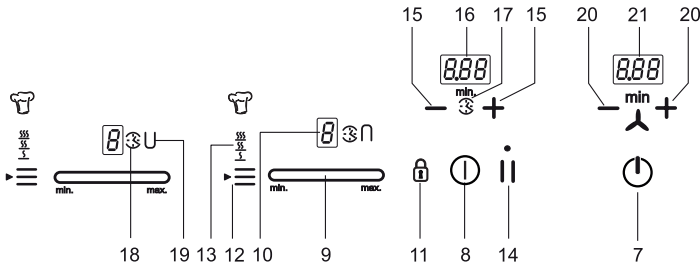

- 7. Standby key
- 8. ON/OFF key (hob)
- 9. Touch control
- 10. Power setting display
- 11. Lock key
- 12. Pre set temperatures
- 13. Display of keep-warm function (3 levels)
- 14. Stop/Pause key (interval sign)
- 15. Minus-/Plus Timer key
- 16. Timer display
- 17. Egg timer
- 18. Display cooking zone timer
- 19. Bridge function
- 20. Minus-/Plus+ fan key
- 21. Fan display

## OPERATING THE HOB

---

The hob is operated with touch control sensor keys. The sensor keys are operated as follows: Lightly touch a symbol on the surface of the ceramic glass plate. A buzzer will indicate when the controls have been operated correctly.

The touch control sensor key will then be indicated as "key".

### **STANDBY KEY:** (7)

With this key, the downdraft extractor is switched operational. The key is like the main switch. After switching off using this button the unit remains on for about 120min in standby mode.

#### **NOTE:**

If the device is switched off completely, no residual heat indicator is displayed.

### **ON/OFF KEY:** (8) **COOKING ZONES LEFT OR RIGHT**

This key is used to switch the left or right hob on and off.

### **POWER SETTING DISPLAY:** (12)

The power setting display shows the power setting which has been selected, or:

**H** Residual heat

**P** Power boost function

**U** Pan recognition





**R** Automatic boost function

**||** Stop/Pause function

**u** Keep-warm function

**L** Lock

**SYMBOLS:**

-    Preset temperature 42°C (Bake) 70°C (keep warm) 92°C (Boil control)
-  Timer/Minute minder function
-  Bridging function (operating cooking zones simultaneously)

**LOCK KEY:  (11)**

The lock key can be used to lock all of the keys.

**PRE-SET TEMPERATURE:  (12)**

For Bake (40°C), keep warm (70°C) and boil control (92°C)

**POWER LEVEL IN THE SENSOR FIELD: **

The power boost setting makes additional power available for induction cooking zones.

**STOP/PAUSE KEY:  (14)**

The STOP/PAUSE function can be used to briefly stop the cooking process.

**RECALL FUNCTION:  (14)**

(Recovery function)

The most recent setting can be recovered if the hob is switched off unintentionally.

**MINUS -/+ PLUS FAN KEY: (20)**

With these keys the power levels of the extractor are selected and the fan run is set.

## THE SLIDER (TOUCH CONTROL)

In principle, the slider functions the same as the touch controls; the only difference is that you can put your finger on the glass ceramic surface and then move it around. The touch control recognises this movement and raises or lowers the display setting (power level) in accordance with the movement. The term touch control is used to mean slider from now on.

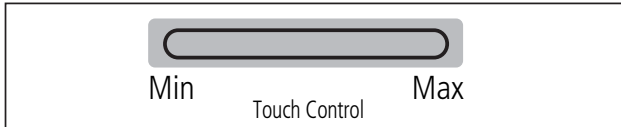

## WHAT MUST BE OBSERVED WHEN OPERATING TOUCH CONTROLS?

Your finger should not be placed flat onto the glass ceramic surface in order to avoid adjacent keys/touch controls from reacting by mistake.

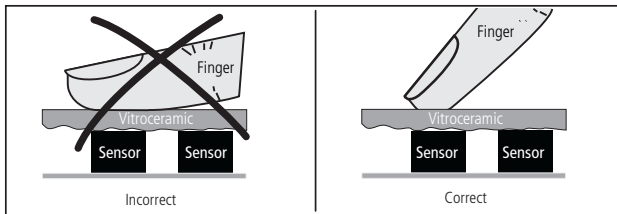

## PRESS THE TOUCH CONTROL LIGHTLY

### OR MOVE YOUR FINGER AROUND

You can press the touch control very lightly with your finger; when this is done the setting on the display (power level) will gradually change. Move to the right to Increase the power level.

When you put your finger on the touch control and then move it to the left or right, the display setting will change progressively. The faster the movement, the faster the change in the display.

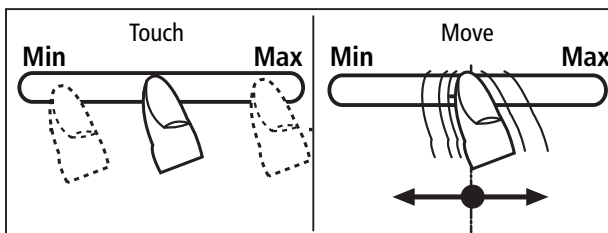

## NOTE:

Pressing a sensor key and keeping it pressed (for approx. 3 seconds) may activate the automatic boost function **R**. See the section on Automatic boost function.

## THE HOB

The hob is equipped with an induction cooking mode. An induction coil underneath the glass ceramic hob generates an electromagnetic alternating field which penetrates the glass ceramic and induces the heat-generating current in the pan base. With an induction cooking zone the heat is no longer transferred from a heating element through the pan into the food being cooked; instead the necessary heat is generated directly in the container by means of induction currents.

### ADVANTAGES OF THE INDUCTION HOB:

- › Energy-saving cooking through the direct transfer of energy to the pan (suitable pots/pans made of magnetisable material are required).
- › Increased safety as the energy is only transferred when a pan is placed on the hob.
- › Highly effective energy transfer between an induction cooking zone and the base of a pan.
- › Rapid heat-up.
- › The risk of burns is low as the cooking area is only heated through the pan base; food which boils over does not stick to the surface.
- › Rapid, sensitive control of the energy supply.

### PAN RECOGNITION:

If a cooking zone is switched on and there is no pan on the zone or if the pan is too small, there will be no transmission of power. A blinking  in the cooking level display points this out.

If a suitable pot or pan is placed on the cooking zone, the power setting will switch on and the power setting display will light up. The power supply will be cut off when the pan is removed and the power setting display will indicate a blinking .

If a pot or pan placed on a cooking zone is smaller than the cooking zone and the pan recognition still switches on, only the amount of power needed will be supplied.

COOKING ZONE DIMENSION (MM)	RECOMMENDED PAN BASE MINIMUM DIAMETER (MM)
220 x 190	115

The base of pots and pans must be of a certain diameter; if it is not, the induction heat will not be switched on.

## IMPORTANT:

The minimum diameter required to activate the pan recognition device may vary according to the type of pot or pan used.

## OPERATION TIME LIMIT:

The induction hob has an automatic time limit function.

The duration of continuous use of each cooking zone depends on the cooking level selected (see chart).



This requires that the setting of a respective cooking zone is not adjusted during use. If the operation time limit has been activated, the cooking zone will switch off, a short signal will sound and an H will appear in the display.

The automatic switch-off function overrules the operation time limit, i.e. the cooking zone is only switched off when the period of time of the automatic switch-off device has expired (e.g. automatic switch-off after 99 minutes and cooking level 9 is possible).

SELECTED COOKING LEVEL	OPERATION TIME LIMIT IN MINUTES
<u>S</u> <u>SS</u> <u>SSS</u> <u>U</u>	120
1	520
2	402
3	318
4	260
5	212
6	170
7	139
8	113
9	90
P	10

## OTHER FUNCTIONS:

If two or more sensor keys are pressed at the same time (e.g. when a pan is mistakenly put onto a sensor key) no function will be activated.

The  symbol will blink and a time-limited continuous signal will sound. After a few seconds the appliance will switch off. Please remove the item located in front of the sensor keys. To delete the  symbol press the same key or switch the hob off and on.

## PROTECTION AGAINST OVERHEATING (INDUCTION):

If the hob is used at full power for a longer period, it will not be possible to cool down the electronics system as required at a high room temperature.

In order to ensure that no excessive temperatures occur in the electronics system, the power of the cooking zones may be reduced automatically.

Should E2 be displayed frequently during normal use of the hob and at normal room temperature, it is likely that cooling is not sufficient.

This may occur if kitchen units have no openings. The installation may have to be checked.

## COOKWARE FOR INDUCTION HOBS:

Cookware for induction cooking zones must be made of metal and have magnetic properties. The base must be sufficiently large.

Only use pans with a base suitable for induction.

SUITABLE COOKWARE	UNSUITABLE COOKWARE
Enamelled steel pans with a thick base.	Pans made of copper, stainless steel, aluminium, oven-proof glass, wood, ceramic and terracotta.
Cast iron pans with an enamelled base.	
Pans made of multi-layer stainless steel, stainless ferrite steel and aluminium with special base.	

## HOW TO ESTABLISH THE SUITABILITY OF A POT:

Conduct the magnet test described below or make sure that the pot bears the symbol for suitability for cooking with induction current.

### MAGNET TEST:

Move the magnet towards the base of your cookware.  
If it is attracted, you can use the cookware on the induction hob.

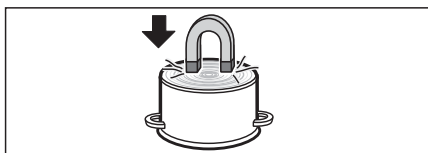

### NOTE:

When using pans suitable for induction from certain manufacturers, noises may occur which are attributable to the design of these pans.

### UNSUITABLE COOKWARE:

The base of the pan is curved.  
The electronic unit cannot determine the temperature correctly.

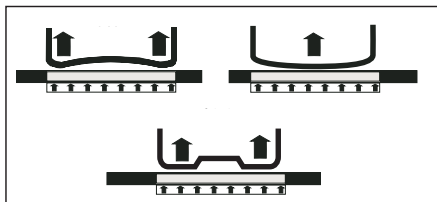

### SUITABLE COOKWARE:

The base of the pan must be flat and smooth.



**ENERGY SAVING TIPS:**

The following are a few useful hints to help you cut your consumption of energy and use your new induction hob and the cookware efficiently.

- › The base of your cooking pans should be the same size as the cooking zone.
- › When buying cooking pans, note that it is frequently the diameter of the top of the pan that is indicated. This is usually larger than the base of a pan.
- › Pressure cookers are particularly low on energy and time cooking required, thanks to the pressure and the fact that they are tightly closed. Short cooking times mean that vitamins are preserved.
- › Always make sure that there is sufficient fluid in your pressure cooker since the cooking zone and the cooker may be damaged as a result of overheating if the pressure cooker boils dry.
- › Always close cooking pots with a suitable lid.
- › Use the right sized pan for the quantity of food you are cooking. A large pan which is hardly filled will use up a lot of energy.

## POWER SETTINGS

The heating power of the cooking zones can be set at various power levels. In the chart you will find examples of how to use each setting.

SETTING	SUITABLE FOR
0	Off, using remaining heat
<b>U</b>	Bake <b>S</b> 42°C
<b>U</b>	Keep warm <b>SS</b> 70°C
<b>U</b>	Boil control <b>SSS</b> 92°C
1-2	Simmering small quantities (lowest power setting)
3	Simmering
4-5	Simmering larger quantities or roasting larger pieces of meat until they are cooked through
6	Roasting, getting juices
7-8	Roasting
9	Bringing to the boil, browning, roasting
P	Power setting (highest power output)

## RESIDUAL HEAT DISPLAY: **H**

The glass ceramic hob is equipped with a **H** as a residual heat display.

As long as the H lights up after the cooking zone has been switched off, the residual heat can be used for melting food or for keeping food warm.

The cooking zone may still be hot when the letter **H** no longer lights up. There is a risk of burns.

The glass ceramic is not directly heated in the case of an induction cooking zone; it is only heated up by heat reflected by the pan.



### NOTE:

If the device is switched off completely, no residual heat is displayed.

## STOP/PAUSE FUNCTION:

The cooking process can be briefly interrupted with the **STOP/PAUSE** function, e.g. if the doorbell rings. The **STOP/PAUSE** function must be released in order to continue cooking at the same power level. If a timer has been set it will pause and will then continue.

This function is only available for 10 minutes for reasons of safety.  
The hob will then be switched off.

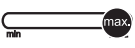
1. Pots and pans are on the cooking zones and the required power levels have been set.
2. Press the **STOP/PAUSE** key  instead of the selected power settings, the interval sign  will light up.
3. The interruption is ended by firstly pressing the **STOP/PAUSE** key  and then the flashing sensorfield  left of the **STOP/PAUSE** key. When operating the sensor field slide over the complete sensor field. The second key must be pressed within 10 seconds as otherwise the stop function remains.

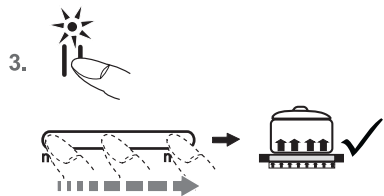

## RECALL FUNCTION: ||

After inadvertently switching the hob off the last setting can be restored.  
The Recall function only works if at least one cooking zone is switched on.

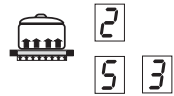

1. The hob is inadvertently turned off by the **ON/OFF** key hob ①.
  2. Within 6 seconds after turning it off, press the **ON/OFF** key hob ① again. The LED on the **STOP/PAUSE** button flashes. Then immediately press the **STOP/PAUSE** key ||.
- The original cooking levels are restored. The cooking process is continued.

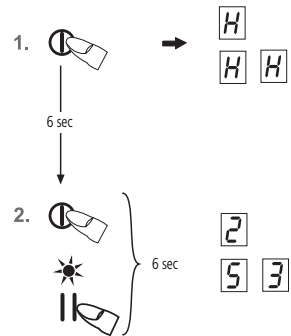

### WHAT CAN BE RESTORED:

- › Cooking levels of all cooking zones
- › Minutes and seconds of programmed timer functions
- › Automatic boost function
- › Power level





### WHAT CANNOT BE RESTORED:

- › Operation time limit (it is counted from 0)

## CHILD LOCK





The childproof lock is to prevent children from accidentally or intentionally turning on the induction hob. The controls are locked.

### ACTIVATING THE CHILD LOCK:

1. Press the **ON/OFF** key hob  (approx. 1 sec) until the power setting shows 0.
2. Immediately afterwards press the Lock key  and the stop key  simultaneously.
3. Subsequently press the Lock key  to activate the child lock. The power setting displays an L for child lock; operation is locked and the hob will switch off.



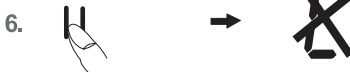

### SWITCHING OFF THE CHILD LOCK:

4. Press the **ON/OFF** key hob 
5. Immediately afterwards press the Lock key  and the stop key  simultaneously.
6. Then press the stop key  to turn off the child lock. The L disappears.



### CANCEL THE CHILD LOCK ONLY FOR A COOKING PROCESS:

Prerequisite: The childproof lock is turned on to step 1 - 3.



- › Press the ON/OFF key hob 
- › Immediately afterwards press the Lock key  and the stop key  simultaneously. Now the user can turn on a cooking zone. After switching off the hob the lock is activated again (switched on).

### NOTE:

In case of a power cut the child lock will be cancelled, i.e. deactivated.

## BRIDGING FUNCTION:

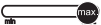
The front and the rear cooking zones may be activated together for a cooking process (bridging function). This enables larger cookware to be used.

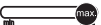
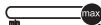
1. Switch on the hob.
2. Press the touch control  of the rear and front cooking zones simultaneously to activate the bridging function. The bridging function is activated, the symbol  appears. Operation is carried out with the touch control  of the front cooking zone.
3. To deactivate the two touch controls  press them simultaneously again or switch off the hob.

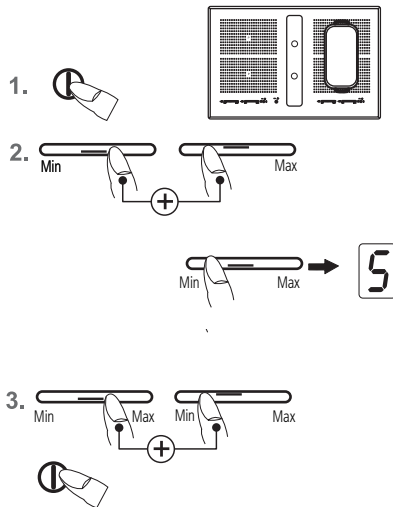

### NOTE:

The pan will need to cover at least half of the cooking zones used in order to be recognised by the pan recognition device.



## AUTOMATIC SWITCH-OFF (TIMER):

The automatic switch-off device is used to automatically switch off any cooking zone after an adjustable period of time. Cooking times ranging from 10 sec (0.10) to 1 h 59 min (1.59) can be set.

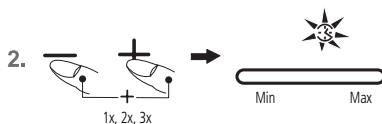
1. Switch on the hob. Switch on one or more cooking zones and select the required power settings.
2. Press the Plus **+** and Minus key **-** simultaneously until the symbol  for the desired cooking zone lights up.
3. To set the time press the Plus **+** or Minus key **-**. After a few seconds your input will be assumed and the procedure will have commenced. The decimal point flashes.
4. The cooking zone will be switched off when the time has lapsed. A signal will sound for a while and can be switched off by pressing the Plus **+** or Minus key **-**.



### NOTE:

- › Repeat steps 2 to 4 to programme the automatic switch-off device for another cooking zone.
- › To check the time that has lapsed (automatic switch-off) push the Plus **+** and Minus key **-** simultaneously until the symbol  for the desired cooking zone lights up. The setting displayed can be read and changed.
- › Terminating the function of the timer: select the cooking zone by pressing the Plus **+** and Minus key **-** simultaneously until the symbol  for the desired cooking zone lights up and press the Minus key **-** to delete the time (0).
- › If several cooking zones have been programmed with the automatic switch-off function, the timer display will always show the cooking zone with the shortest time.

## MINUTE MINDER (EGG TIMER):

1. Switch on the hob.
2. Press the Plus **+** and Minus key **-** simultaneously until the symbol  under the timer display lights up.
3. To set the time press the Plus **+** or Minus key **-** . After a few seconds your input will be assumed and the procedure will have commenced. The decimal point flashes.
4. Once the time has lapsed a signal will sound for a while and can be switched off by pressing the Plus **+** or Minus key **-** .

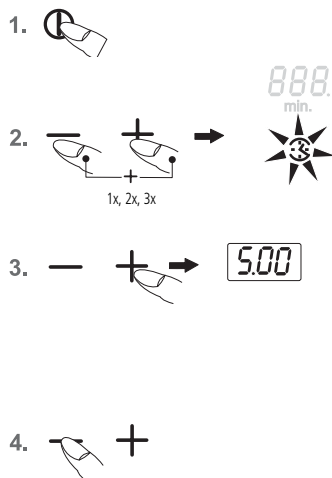

## SETTING TIMER IF COOKING ZONES ARE IN OPERATION:

- › Press the Plus **+** and Minus key **-** simultaneously until the symbol  under the timer display lights up.
- › To set the time press the Plus **+** or Minus key **-** .
- › Once the time has lapsed a signal will sound for a while and can be switched off by pressing the Plus **+** or Minus key **-** .

### NOTE:

The minute minder remains in operation when the left or right hob is switched off. Switch the left or right hob on to adjust the time.

## AUTOMATIC BOOST FUNCTION: **A**

When the automatic boost function is selected, food is part-boiled at power setting 9. After a certain time (see chart), the power level will switch down automatically to a lower simmering setting (1 to 8).

When using the automatic boost function only the power setting with which the food is to be cooked through needs to be selected since the electronic unit switches down automatically.

The automatic boost function is suitable for dishes which are cold initially and are then heated up at high power. These dishes do not need to be constantly monitored when cooking (e.g. boiling meat for soups).

SELECTED POWER LEVEL	AUTOMATIC BOOST FUNCTION TIME (MIN:SEC)
1	0:40
2	1:12
3	2:00
4	2:56
5	4:16
6	7:12
7	2:00
8	3:12
9	-

1. Switch on the hob.
2. Press the touch control and keep it pressed (for approx. 3 seconds) to activate the function and immediately select a specific power setting:

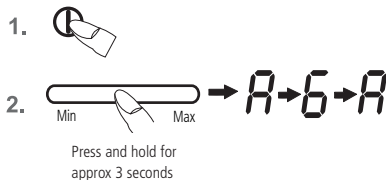
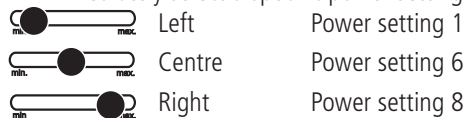

The symbol **A** will light up. This will activate the automatic boost function. **A** and the selected simmering setting will blink alternately.

3. The automatic boost function will operate as programmed. After a certain time (see chart) the cooking process will be continued with the power setting. The **A** symbol will go off.

3. **6**

### NOTE:

The power setting can be raised while the automatic boost function is in operation. A reduction in the power setting will switch off the automatic boost function.

## PRE SET TEMPERATURES

With this function  you can use one of the cooking zones to keep food warm, help with baking or control the boiling. The respective cooking zone is operated at a low power level.

1. Cookware is placed on a cooking zone and a power level (e.g. 3) is selected.



2. By repeatedly pressing the pre set temperature key  select the setting:





 corresponds to about 42°C - bake



 corresponds to about 70°C - keep warm

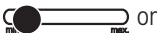

 corresponds to about 92°C - boil control

3. To switch off the function press the touch control  on the far left or press the key .



The keep-warm function is available for 120 minutes, after which the cooking zone will be switched off.

## LOCKING

The lock can be used to lock key operation and cooking level settings. Only the ON/OFF key can be used to switch the hob off.

### ACTIVATING THE LOCK:

1. Press the Lock key  to activate the function. The control lamp above the Lock key will light up. The controls are locked.



### SWITCHING OFF THE LOCK:

2. Press the Lock key  to deactivate the function. The control lamp above the Lock key will go off.



### NOTE:

- › An activated lock will remain activated even if the hob is switched off. It must therefore be de-activated when cooking is re-commenced.
- › In the event of a power cut the lock will be cancelled, i.e. deactivated.

## POWER BOOST **P**

The power boost setting makes additional power available for induction cooking zones. A large quantity of water can be brought to the boil very quickly.

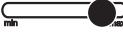
1. Switch on the hob.
2. Press the respective touch control  on the far right to allocate it to a specific cooking zone. The power setting display shows **P** and the power boost setting has been switched on.
3. After 10 minutes the power boost setting will switch off automatically. The **P** will go off and power setting 9 will be reset.

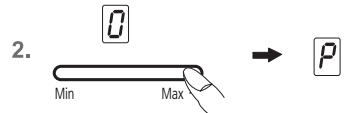

### NOTE:

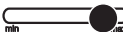
Press the respective touch control  to prematurely switch off the power boost setting.

### POWER MANAGEMENT:

For technical reasons two cooking zones always comprise a module and have a maximum power level.

If this power range is exceeded when a higher power setting level or the power boost function is switched on the power management system will reduce the power setting of the corresponding cooking zone of the module. The display for this cooking zone will initially blink, after which the highest possible power setting will be consistently displayed.

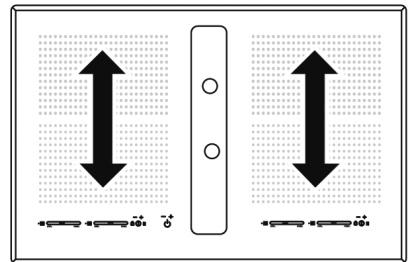

Modules (power management)

## OPERATING THE DOWNDRAFT:





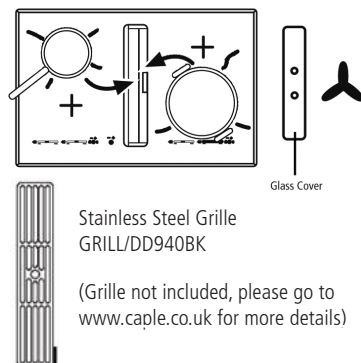

In the centre of the hob, the fan is positioned with the air exhaust downward.

Remove the glass cover completely before using the fan.

The stainless steel grill cover does not have to be removed.



### SWITCHING THE FAN ON AND OFF:



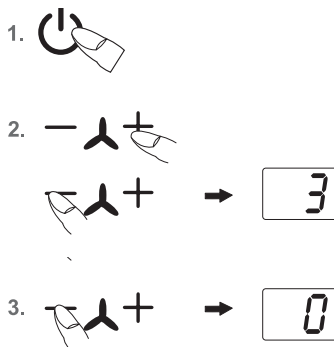

1. Press the Standby key  (about 1 sec.) until the unit goes into standby mode.
2. Press the plus key  from the fan. Then you can choose with the plus  or minus key  a desired power level 1, 2, 3 or 4. The symbol for the fan  lights up. The intensive level 4 remains for 10 minutes, then it will automatically switch back to level 3.
3. To switch off the fan press the minus key  until 0 is displayed.



### FAN TIMER:

The fan timer is used after cooking to completely eliminate cooking odours. In addition, the filters are dried in the fan timer.

### SETTING THE FAN TIMER:

1. Press the plus  and minus key  from the fan simultaneously. The fan timer is set for 10 minutes. It lights up the symbol **min** for fan timer.
2. Press the plus  and minus key  again simultaneously to set the fan timer for 60 minutes.
3. By pressing the keys again simultaneously, the fan timer will switch off.

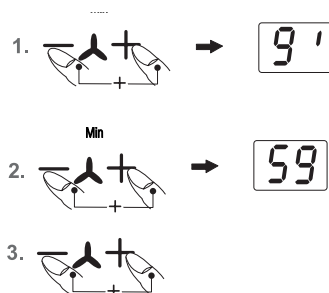

**STOP DELAY TIME:**

The fan motor should continue operating for another 10-20 minutes every time the hob has been used for cooking. When the fan is switched off after having been in operation for at least 15 minutes, an automatic time lag at a low setting will follow for around 15 minutes.

This guarantees optimal functioning and the removal of remaining cooking steam.

When using a recirculating air filter, please always allow for a stop delay time of 10 - 60 minutes in order to optimally remove cooking odours.

When the fan is switched on again, in rare cases the odour molecules present in the filter may be combined with steam so that they are detected again. These remaining odours will disappear when the fan continues to operate.

**IMPORTANT:**

When the convection air mode is in operation, ventilation must be sufficient in order for the air humidity to be removed.

## CARE AND MAINTENANCE

---

- › Switch the hob off and let it cool down before you clean it.
- › Never clean the glass ceramic hob with a steam cleaner or similar appliance.
- › When cleaning make sure that you only wipe lightly over the **ON/OFF KEY**. The hob may otherwise be accidentally switched on.

### **GLASS CERAMIC HOB IMPORTANT NOTE:**

Never use aggressive cleaning agents such as rough scouring agent, abrasive saucepan cleaners, rust and stain removers etc.

Cleaning after use:

- › Always clean the entire hob when it has become soiled. It is recommended that you do so every time the hob is used. Use a damp cloth and a little washing up liquid for cleaning. Then dry the hob with a clean dry cloth to ensure that there is no detergent left on the surface of the hob.

### **WEEKLY CLEANING:**

- › Clean the entire hob thoroughly once a week with commercial glass ceramic cleaning agents. Please follow the manufacturer's instructions carefully. When applied, the cleaning agent will coat the hob in a protective film which is resistant to water and dirt. All the dirt will remain on the film and can then easily be removed. Then rub the hob dry with a clean cloth. Make sure that no cleaning agent remains on the surface of the hob since this will react aggressively when the hob is heated up and will change the surface.

### **GREASE FILTER:**

After a period of time, the grease filters will start to become saturated in fat and grease. Because of this, these should be washed regularly (roughly once every 2 months). The grease filters can be washed by hand with warm soapy water or in the dishwasher. These filters need to be cleaned on a regular basis, because otherwise they may represent a fire risk. Once cleaned, refit to the downdraft, and reapply the glass top. Please note that some dishwasher detergents can cause the grease filter to discolour, this is normal and is not a fault.

## SPECIFIC SOILING:

Heavy soiling and stains like limescale and shiny, mother-of-pearl type stains are best removed when the hob is still slightly warm. Use commercial cleaning agents to clean the hob. Proceed as outlined under Care and Maintenance.

First soak food which has boiled over with a wet cloth and then remove remaining soiling with a special glass scraper for glass ceramic hobs. Then clean the hob again as described under Care and Maintenance.

Burnt sugar and melted plastic must be removed immediately, when they are still hot with a glass scraper. Then clean the hob again as described under Care and Maintenance.

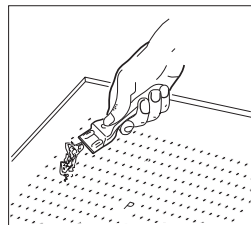

Grains of dirt which may get onto the hob when you peel potatoes or clean lettuce may scratch the surface of the hob when you move pots around. Make sure that no grains of dirt are left on the hob.

Changes in the colour of the hob will not affect the function and the stability of the glass ceramic material. These colour changes are not changes in the material but food residues which were not removed and which have burnt into the surface.

Shiny spots result when the base of the cookware rubs on the surface of the hob, particularly when cookware with an aluminium base or unsuitable cleaning agents are used. They are difficult to remove with standard cleaning agents. You may need to repeat the cleaning process several times. In time, the decoration will wear off and dark stains will appear as a result of using aggressive cleaning agents and faulty pan bases.

## TROUBLESHOOTING

---

Interference with and repairs to the appliance by unqualified persons are dangerous as they can result in an electric shock or a short circuit. Do not interfere with or try to repair the appliance; this could cause injury to persons and damage to the appliance. Always have such work done by a Caple approved engineer or similar qualified persons.

### **PLEASE NOTE:**

If your appliance is faulty, please check whether you can rectify the problem yourself by consulting these instructions for use.

You may be able to rectify some problems yourself. They are described below.

### **THE FUSES BLOW REGULARLY?**

Contact Caple Service or an electrician.

### **YOU CAN'T SWITCH YOUR INDUCTION HOB ON?**

- › Has the wiring system (fuse box) in the house blown a fuse?
- › Has the hob been connected to the mains?
- › Are the sensor keys locked (childproof lock)?
- › Are the sensor keys partly covered by a damp cloth, fluid or a metallic object? Please rectify.
- › Are you using unsuitable cookware? See the section on "Cookware for induction hobs"

### **THE SYMBOL WILL BLINK AND A TIME-LIMITED CONTINUOUS SIGNAL WILL SOUND.**

Food which has boiled over, cookware or other items are causing the touch control sensor keys to be consistently operated.

Clean the surface or remove the item.

To delete the  symbol, press the same key or switch the hob off and on.

**ERROR CODE E2 IS INDICATED?**

The electronic unit is too hot. Check the installation of the hob.

Make sure that there is sufficient ventilation.

See the section on "Protection against overheating".

See the section on "Ventilation".

**ERROR CODE E8 IS INDICATED?**

Fault on the left or right fan.

The suction opening is blocked or covered or the fan is defect.

Check the installation of the hob. Make sure that there is sufficient ventilation.

See the section on "Ventilation".

**ERROR CODE U400 IS INDICATED?**

The hob has been incorrectly connected. The controls will switch off after 1 second and a continuous signal will sound. Connect the appliance to the appropriate power supply.

**AN ERROR CODE (ERXX OR EX) IS INDICATED?**

The appliance has developed a technical defect. Please call Caple Service.

**THE POT SIGN U APPEARS?**

A cooking zone has been switched on and the hob is expecting a suitable pot or pan to be placed on the cooking zone (pan recognition). Only when a pot has been placed on the cooking zone will power be supplied.

**THE POT SIGN U STILL APPEARS, EVEN THOUGH A POT OR PAN WAS PLACED ON THE HOB?**

The cookware is unsuitable for induction cooking or the pot or pan is too small.

**IS THE COOKWARE YOU ARE USING MAKING NOISES?**

This is due to technical reasons and perfectly normal; the induction hob and the pan are not at risk.

**DOES THE COOLING FAN STILL OPERATE AFTER IT HAS BEEN SWITCHED OFF?**

This is normal since the electronic unit is being cooled down.

### **IS THE HOB MAKING NOISES (CLICKING OR CRACKING SOUNDS)?**

This is for technical reasons and cannot be avoided.

### **DOES THE HOB HAVE TEARS OR CRACKS?**

There is a risk of electric shocks if the glass ceramic hob develops fractures, cracks, tears or damage of any other kind. Immediately switch off the appliance. Disconnect the fuse immediately and call Customer Service.

## SAFETY INSTRUCTIONS FOR KITCHEN UNIT FITTERS:

- › Veneers, adhesives and plastic surfaces of surrounding furniture must be temperature resistant ( $>75^{\circ}\text{C}$ ). If the veneers and surfaces are not sufficiently heat resistant they may become deformed.
- › Ensure that all live connections are safely insulated when installing the hob.
- › Cover Strips between the wall and the worktop behind the hob which are made of solid wood are permissible as long as minimum clearances in accordance with the installation diagrams are maintained.
- › Minimum clearances of the hob cut-out towards the rear are to be maintained in accordance with the installation diagram.
- › For installation directly next to a tall cupboard, a safety distance of at least 50mm must be ensured. The side surface of the tall cupboard should be fitted with heat resistant material. Due to working requirements, however, the distance should be at least 300mm.
- › The packaging materials (plastic foil, polystyrene, nails etc.) must be kept out of reach of children as these parts are potentially dangerous. Small parts can be swallowed and there is a danger of plastic sheeting causing suffocation.

## VENTILATION:

- › The induction hob is equipped with a ventilator. The ventilator switches on or off automatically. If the temperature produced by the electronic device exceeds a certain level, the ventilator turns on in low speed. In case the induction hob is being used intensively, the ventilator switches to a higher speed. If the electronics are cooled sufficiently, the ventilator reduces the speed and switches off automatically.
- › Clearance between the induction hob and kitchen furniture or built-in units must provide for sufficient ventilation of the induction hob.
- › If the power level of a cooking zone is automatically raised or lowered (see section on thermal cut-off device) it is likely that the cooling system does not cool sufficiently. In this case we recommend that the back wall of the bottom kitchen unit in the area of the worktop cut-out be opened and that the front transverse strip of the unit be removed over the entire width of the appliance in order to promote the circulation of air.

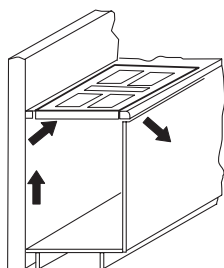

In order to better ventilate the hob, an air gap of 5mm should be left at the front.

## INSTALLATION

---

### IMPORTANT INFORMATION:

- › Remove any transverse strips underneath the worktop at least in the area of the worktop cut-out.
- › When installing the appliance on top of a drawer it is essential to ensure that no sharp items are stored in the drawer since these could become bent on the underside of the hob and prevent the drawer from being opened and closed.
- › If a shelf has been inserted underneath the hob, there must be a clearance of at least 20mm to the underside of the hob in order to ensure that the hob is sufficiently ventilated.
- › To avoid danger of fire, make sure that no combustible objects which could easily catch fire or become deformed on exposure to heat are directly next to or under the surface.

### SEALING OF THE HOB

Before installation, correctly insert the sealing unit delivered with the hob.

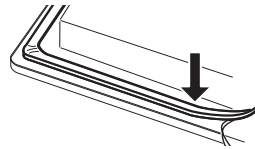

- › No liquids may penetrate between the edge of the hob and the worktop or between the hob and the wall and come into contact with any electrical appliances.
- › When installing a hob into an uneven worktop, e.g. with a ceramic or similar covering (tiles etc.), the seal on the hob is to be removed and the seal between the hob and worktop made with plastic sealing materials (putty).
- › The hob must under no circumstances be sealed with silicone sealant. This would make it impossible to remove the hob at a later date without damaging it.

## WORK SURFACE CUT-OUT:

Cut out the worktop recess accurately with a good, straight saw blade or recessing machine. The cut edges should then be sealed so that no moisture can penetrate.

The area is cut out as illustrated. The glass ceramic hob must have a level and flush bearing. Any distortion may lead to fracture of the glass panel. Make sure that the sealing of the hob is properly seated.

If fitting flush, an expansion gap of 2mm should be left around the hob top (904 x 584mm).

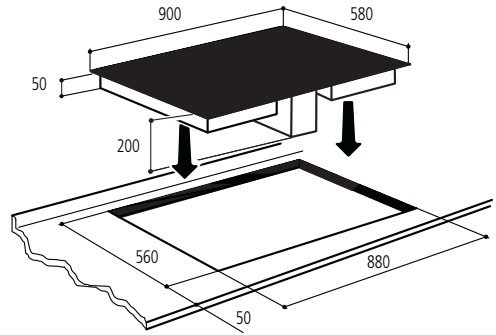

## FLUSH INSTALLATION

Glue the sealing tape onto the corner of the supporting edge of the worktop so that no silicone adhesive can be pressed under the hob.

Place the hob into the worktop cut-out without any adhesive and align it. Use shims if necessary.

Fill the gap between the hob and the worktop with heat-resistant silicone adhesive.

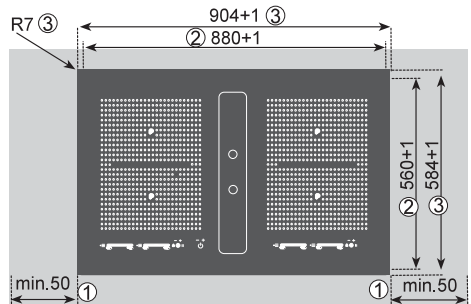

## IMPORTANT:

Silicone adhesive must not get under the support surface. If this occurs it will not be possible to remove the hob again at a later stage. No liability will be assumed in the case of failure to observe these instructions.

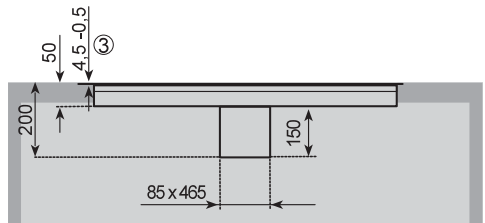

## MAKING THE WORKTOP RECESS

The cut-out is produced in two work steps:

1. Making the opening for the base trough.
2. Making the recess for the support of the glass ceramic hob. (For this recess at least a recessing machine with guide strip is required.)

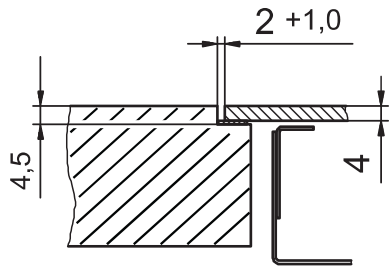

The outside dimension of the recess should always be about 6 mm longer than the outside dimension of the glass ceramic hob so that a seal can be provided (see: "Gluing in the hob").

Alternatively, instead of carrying out the second stage, the support of the glass ceramic hob can be cut out completely and then glued in again with the height adjusted. It is also possible to install strips of wood or stone as well as steel angles.

1. Make the opening for the hob.
2. Fix the strip of wood or stone or the supporting angle onto the worktop.

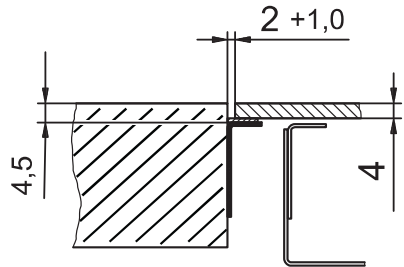

### NOTE:

In order to ensure that it is exactly flush with the stone worktop, the recess may have to be modified accordingly.

## SILICONING THE HOB

In order to avoid damage to the worktop and the hob, it is necessary to silicone the system worktop/hob with a permanent seal so that it is water-proof.

- › The parts to be siliconed together must be dry and free from grease.
- › To silicone the hob, a water-proof wash primer and the heat and moisture-resistant silicone adhesive (150°C) is required. It is absolutely necessary to observe the remarks concerning these two products.
- › There you will also find a calculation formula for the hardening of the silicone adhesive. Do not operate the cooking zone before the hardening process is over, otherwise the silicone adhesive can be damaged.
- › Only silicone the hob on its outer edges.
- › With stone worktops installation is to be flush, with heat-sensitive worktops (e.g. wood) the hob must project about 1mm.
- › Never place the hob with the glass ceramic surface unprotected on the worktop or the floor. Dirt (metal chips, small pieces of stone etc.) can cause scratches in the surface of the glass ceramic hob. Please always place it on cardboard or a wool rug.

## PROCEDURE:

1. Glue the sealing tape ① onto the corner of the supporting edge of the worktop so that no silicone adhesive ② can be pressed under the hob.

## IMPORTANT:

Only use the sealing tape that is supplied with the hob. Should you use any other sealing there is no guarantee that the hob will not sink down after installation.

2. Only use the sealing tape that is supplied with the hob. Should you use any other sealing there is no guarantee that the hob will not sink down after installation.
3. Insert the hob without adhesive into the worktop opening and check the height. If necessary, place the shims on the support edge for the hob at equal distances to adjust the height.
4. Remove the hob again.

## IMPORTANT:

After application, the primer must be left for about 30 minutes.

5. Now insert the hob and align.

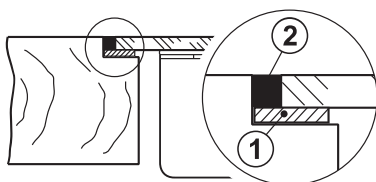

6. Finally, fill the gap between the hob and the worktop with silicone adhesive (2)

7. Smooth the joint with a spatula and water containing a little washing-up liquid.

**ATTENTION:**

Sealing tape (1) and silicone adhesive (2) should not be pressed anywhere under the supporting surface, otherwise it will no longer be possible to remove the hob at a later stage. No liability will be assumed in the case of failure to observe these instructions.

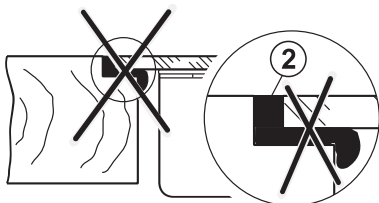

## ELECTRICAL CONNECTION

- › The electrical connection must be carried out by a qualified electrician who is authorised to carry out such work.
- › Statutory regulations and the connection specifications issued by the local power supply company must be strictly observed.
- › When connecting the appliance it must be ensured that there is a device which makes it possible to disconnect it from the mains at all poles with a contact opening width of at least 3mm. Line-protecting switches, fuses or contactors are suitable cut-out devices. When connecting and repairing the appliance, disconnect it from the electricity supply with one of these devices.
- › The earth wire must be sufficiently long so that if the strain relief fails, the live wires of the connecting cable are subjected to tension before the earth wire.
- › Any unnecessary cable must be removed from the installation area beneath the appliance.
- › Make sure that the local mains voltage is the same as the voltage on the rating label.
- › Full protection against accidental contact must be ensured on installation.

### ATTENTION:

Incorrect connection may result in the power electronics unit being destroyed.

Power supply -Mains voltage: 380-415V 3N~, 50/60Hz

Component rated voltage: 220-240V

Fuse rating: 32amp

## MAINS CABLE

- › The hob has been fitted with a temperature-resistant connection cable.
- › Connection to the mains is carried out in accordance with the circuit diagram, unless the connection cable is already fitted with a plug.
- › If the mains cable of this appliance is damaged it will need to be replaced with a special connection cable. In order to avoid any risks, this must be carried out by Caple Service or an approved engineer.

## ELECTRICAL CONNECTIONS

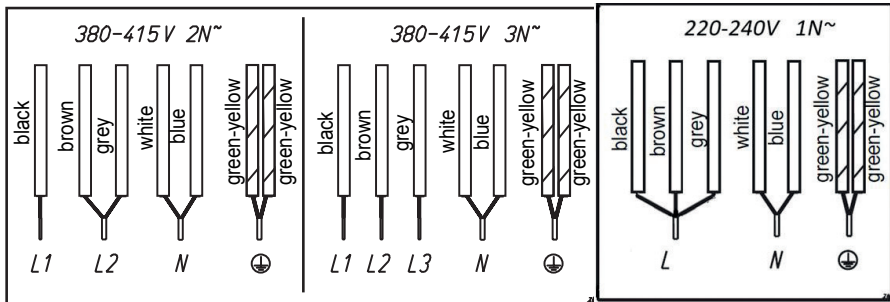

## TECHNICAL DATA

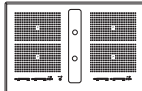
Hob dimensions [Height/Width/Depth]	200 x 900 x 580mm 
Cooking Zones	
All: cm/KW Fan: kW	19 x 22/ 2,2 [3,7]* 0,3
Hob KW	7,7

\* Power when the power boost function is activated

## PUTTING THE APPLIANCE INTO OPERATION

Once the hob has been installed and the power supply has been provided (mains connected) an automatic test of the controls will be carried out and service information will be indicated.

### IMPORTANT:

No items may be on the touch control sensor keys when the appliance is being connected.

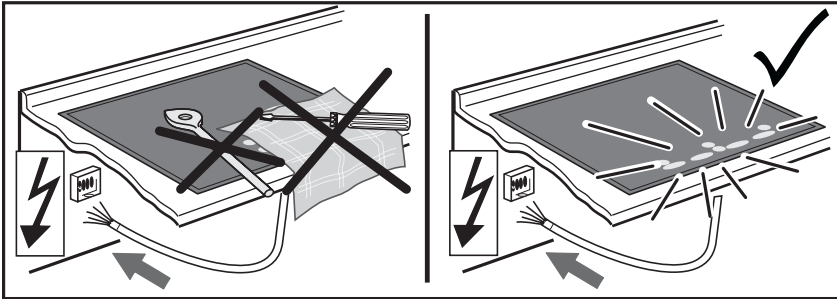

Briefly wipe over the surface of the hob with a sponge and soapy water and then dry with a clean cloth.

## INSTALLATION OF THE PLINTH MOTOR

The motor supplied with your downdraft induction hob is designed to be installed below the kitchen cabinets behind the plinth. It can be used to either duct to the outside via an external wall or recirculate the air back into the room.

### MOTOR ELECTRICAL CONNECTION

Ensure the hob is not connected to the mains while connecting the motor. The motor unit does not require a separate mains supply, you simply plug in the 7pin cable supplied into the induction hob to power the unit.

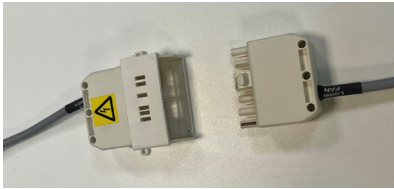

Motor male connection fits to the relevant hob female connection

The motor does not need to be fixed into position with screws or other fixings. To avoid excessive noise we recommend positioning the motor onto a noise and vibration reducing base.

The direction of airflow is as shown below:

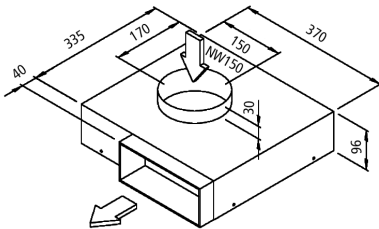

### CONNECTING THE DUCTING TO THE MOTOR

The below components are supplied in the box to allow you to connect the downdraft hob to your plinth motor:



The ducting must be connected to the right hand side of the downdraft in the centre of the hob:

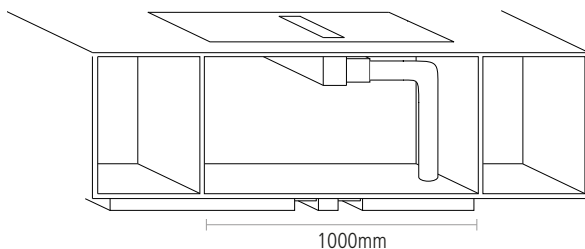

You can then use the supplied ducting sections to connect to the motor in the most suitable location. There are various options including going straight down in the below cabinet or extending the duct channel to the right into an adjacent 300mm cabinet, which can house the round 150mm tube. The latter method allows the most use in the cabinet below the hob as the main part of the ducting is housed in a 300mm wide cabinet to the right of the product.

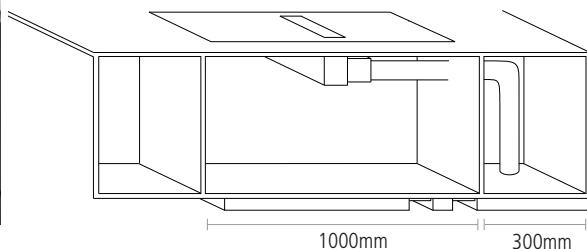

If you choose to run the ducting inside the cabinet directly below the hob, you can still achieve the use of full depth drawers and full width drawer fronts by installing a divider inside the main carcase as pictured below (the drawer boxes must be reduced in width to allow for the divider):

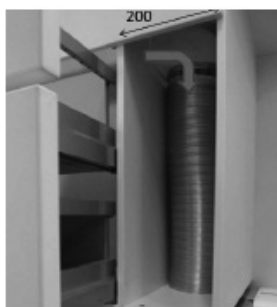

The divider must allow a 200mm wide space for the ducting to be housed in, the remaining room can then be used for the drawers. For example with a 1000mm wide base unit, you would install a 200mm divider, which would allow for 800mm wide drawer boxes. These drawers would still use full width 1000mm wide drawer fronts, therefore when closed you have the appearance of a standard drawer set.

### L-Shaped kitchen attached to the wall

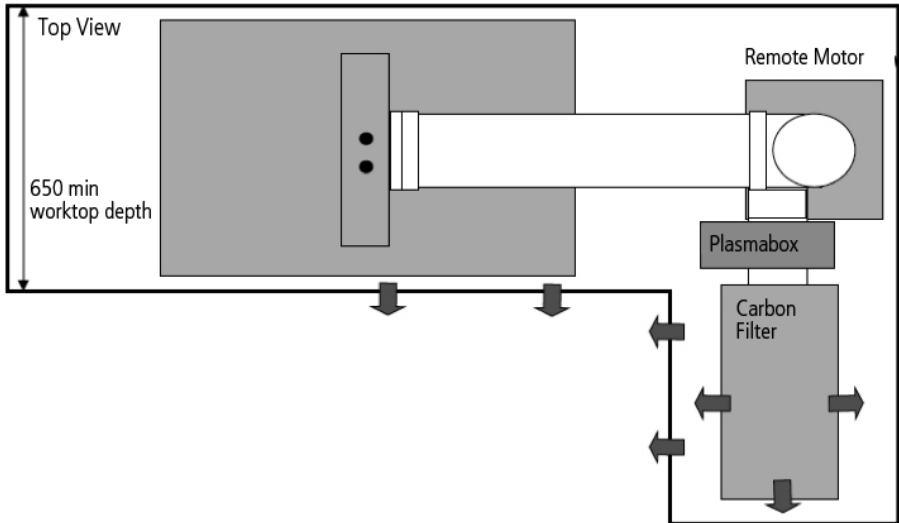

## Island with plinth depth 120cm

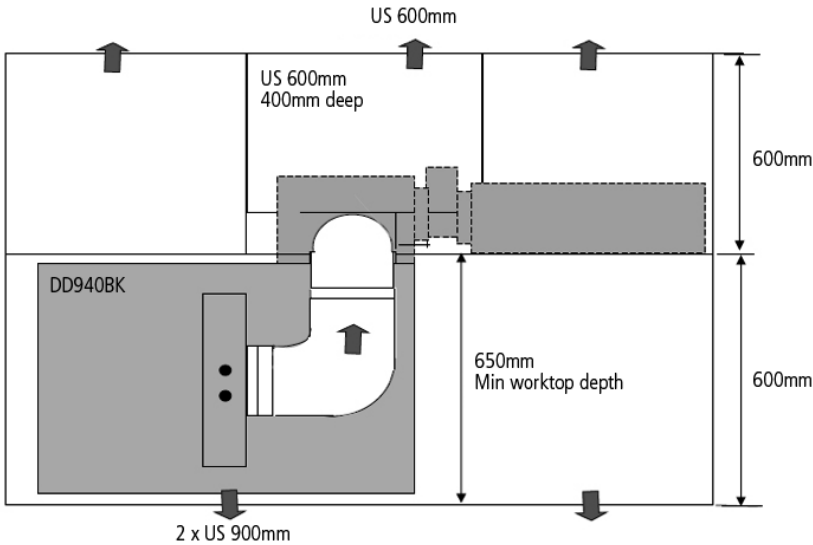

Reduced plinth height all around for sufficient air outlet

### NOTE:

The above installation would allow for two full depth drawers.

### DUCTING TO THE OUTSIDE

When ducting to the outside, 150mm solid rigid (220mm x 90mm flat channel) must be used and the length should be kept to a minimum. We recommend no more than 3 meters with two 90 degree bends. If the flat channel duct is completely straight up to 5 meters is acceptable. Any more than this will begin to effect the efficiency of the motor.

Avoid unnecessary bends, if bends are required use high efficiency corners (for example the Caple 950GL 150mm) to reduce the impact on performance.

### RECIRCULATION MODE

The product can be recirculated by two methods:

- › Plasma filtration
- › Charcoal filter only

## PLASMA FILTRATION

---

With this product, you have the option to use our new Plasma technology. This allows you to recirculate the air with a very efficient odour removal process. The optional plasma filter (code PLASMABOX) and charcoal filter (code: CAP57CF) are cleverly hidden away in the plinth below the cabinets, so there is no need to duct the product to the outside wall. You can also install all the pipework into a 300mm wide carcass space allowing for a lot more use of the kitchen cupboard when compared to a conventional downdraft. The Plasma technology also extends the life of the charcoal filter from around 6 months to 5 years, 1 filter will last the equivalent of 10 without the Plasmabox.

For more information on the Plasma technology please visit our website [www.caple.co.uk](http://www.caple.co.uk) to view our informative video, this can also be found on our YouTube channel CapleTV, or by scanning the below barcode.



The plasma box simply connects to the motor outlet and is powered by the electrical cable supplied with the hob. The plasma box male connection fits to the relevant hob female connection shown below.

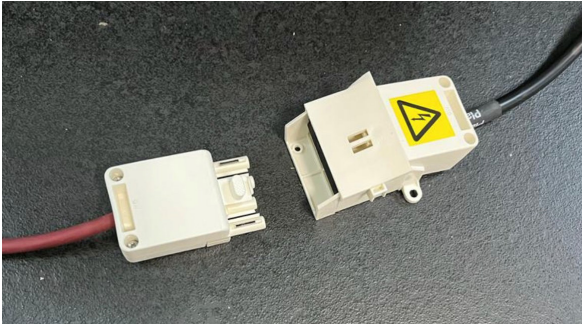

When using the plasma filter, a charcoal filter (CAP57CF) must also be installed. This simply slots into the opposite end of the plasma box.

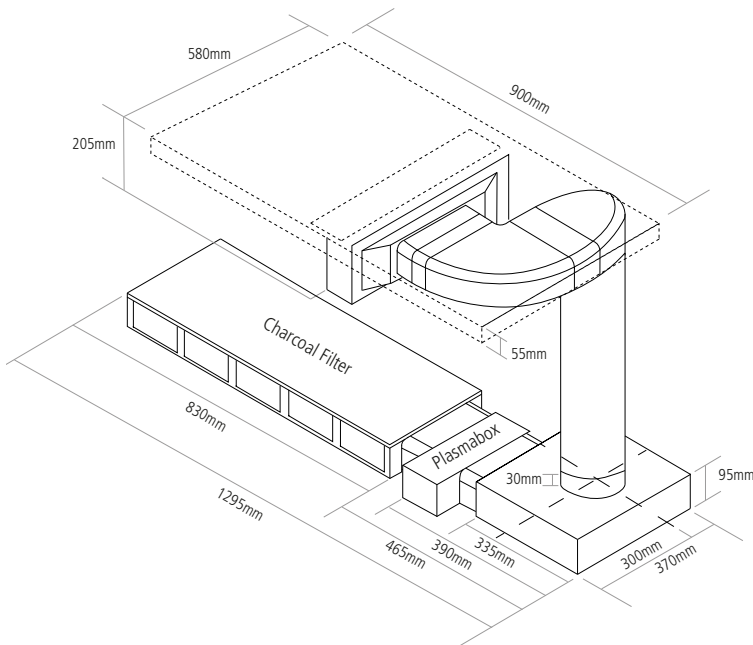

The Plasmafilter required on ambient temperature of 0°C - 40°C.

## **CHARCOAL FILTER ONLY**

When using the charcoal filter (CAP57CF) only to recirculate the air, this connects directly to the motor in the same location as the plasmabox pictured above. The charcoal filter must be replaced at least every 6 months to ensure it remains effective. Replacement filters can be purchased from [www.caple.co.uk](http://www.caple.co.uk) or via our national sales office tel: 0117 938 1900.

## **GREASE FILTER**

The grease filter is located in the downdraft hob top (refer to earlier section in the manual), this must be cleaned at least every two months. We recommend cleaning it in warm water with washing up liquid, ensuring it is thoroughly dried before placing back into the downdraft. The grease filter can also be cleaned in a dishwasher, if this method is used it should be washed on its own to prevent food becoming trapped in the mesh. Please note that some dishwasher detergents can cause the grease filter to discolour, this is normal and is not a fault.

## **AFTER SALES SERVICE**

---

Any maintenance operation on your appliance should be carried out by:

- › Either your retailer;
- › Or another Caple approved engineer or similar qualified person.

If a problem still persists and further assistance is required, please contact our Caple after sales team on:

**T - 0117 938 7420**

**E - [service@caple.co.uk](mailto:service@caple.co.uk)**

**NOTES:**

**NOTES:**



Caple Service

BS11 8DW

Fourth Way

T: 0117 938 1900

Avonmouth

E: [service@caple.co.uk](mailto:service@caple.co.uk)

Bristol

[www.caple.co.uk](http://www.caple.co.uk)