

## Instruction manual for frost free fridge freezer

Model code: Ri737



1. **Compression-type appliances** which use **flammable refrigerants** shall be marked with the symbol "Caution: risk of fire".



Caution: risk of fire

Symbol ISO 3864-B.3.2

The height of the triangle in the symbol "Caution: risk of fire" shall be at least 15 mm.

2.

- WARNING: Keep ventilation openings, in the appliance enclosure or in the built-in structure, clear of obstruction.
- WARNING: Do not use mechanical devices or other means to accelerate the defrosting process, other than those recommended by the manufacturer.
- WARNING: Do not damage the refrigerant circuit.
- WARNING: Do not use electrical appliances inside the food storage compartments of the appliance, unless they are of the type recommended by the manufacturer.

Do not store explosive substances such as aerosol cans with a flammable propellant in this appliance.

3.

If the supply cord is damaged, it must be replaced by a special cord or assembly available from the manufacturer or its service agent.

This appliance is not intended for use by persons (including children) with reduced physical, sensory or mental capabilities, or lack of experience and knowledge, unless they have been given supervision or instruction concerning use of the appliance by a person responsible for their safety.

Children should be supervised to ensure that they do not play with the appliance.

Protecting the environment and advice for disposal-----2

Deciding where to locate your fridge freezer-----2

Installing your appliance/Danger warnings-----2

Rating plate-----3

Connecting your appliance to the mains-----3

Using your appliance-----3

Starting up the freezer-----3

Freezing/Storing of fresh food-----3

Cleaning and maintenance-----4

Using your fridge-----5

Troubleshooting guide-----6

Installing your appliance-----7

Congratulations on purchasing your new Caple appliance. Please read these user instructions carefully to understand, quickly and thoroughly, how to use your new fridge freezer. Underline any parts you consider particularly important. Look after this document so that you may consult it in future or pass it on to any future owners.

You have purchased a reliable appliance which will serve you for many years if it is used and maintained properly. Detailed illustrations can be found on the last pages of this user manual, the performance data on the rating plate refer to a room temperature within the range of +10°C to 38°C.

**Important!**

This appliance is designed for domestic use only.

The appliance has been tested against leakage in compliance with the relevant legal safety standards. If you have bought your new fridge freezer to replace an old appliance, please make sure that all existing latch or bolt-locks on the old appliance are destroyed before you dispose of it. This will ensure that a child can not get trapped inside. Please have the old appliance ecologically disposed of by a company specialised in environmental protection, as the appliance may contain harmful components in the refrigerant and this must be removed with special equipment. Please check with your dealer or your local authority.

Make sure that the refrigerating system containing the refrigerant, especially the condenser at the back of the appliance are not damaged during transportation to the disposal site. So you can be sure that the refrigerant does not leak out. Details of utilized refrigerant and insulation propellant are on the rating plate affixed to the appliance.

The user instructions apply to several models, for this reason there may be some differences in the details given, according to the type of the appliance.

### 1. Protecting the environment / advice for disposal

Packing serves to protect the appliance during transportation and recyclable materials have been used for the packaging. Corrugated board/cardboard (mainly from waste paper)

- Shaped parts in PS( foamed CFE-free Polystyrene)
- Foils and bags in PE (Polyethylene)
- Strapping tapes in PP( Polypropylene)

Please hand over all packaging to the nearest official collection point, so that all the different materials can be reused or recycled as far as possible and any illegal depositing of such materials is avoided.

### 2. Deciding where to locate your appliance

In order to avoid any damage or injury to persons or things, the appliance should be unpacked by two people and placed in the chosen location. Before positioning it, check that your new appliance has no visible outer damage. On no account should you start up your appliance if it is damaged. Check the appliance carefully for:

- Damage to the packaging which might indicate that the appliance has been mishandled during transportation.
- Damage to the outer case.
- Any visible damage to the cable or plug.

If in any doubt let the customer service department check the appliance. It must at all costs be avoided that any environmentally damaging refrigerant leaks out by starting up the appliance.

### 3. Installing your appliance

- a) Unpack the appliance
- b) In order not to unnecessarily waste raw materials, the handles have not been mounted on to the separate part of the appliance (not applicable for Ri558). Mount the door handles and at the same time any other enclosed parts according to the relevant instructions enclosed.
- c) Remove any objects from inside the appliance
- d) Carefully remove all film and adhesive tape.
- e) Remove any polystyrene pieces from around the compressor (if present)
- f) Remove all documents and accessories inside
- g) Clean the inside of the appliance with lukewarm water and vinegar and dry it thoroughly with a soft cloth.

- Make sure that the pipes for the circulation of the refrigerant are not damaged in any way during installation.
- The appliance must only be used for the purpose for which it is intended.
- The appliance must be placed on a firm, level surface. This is the only way to ensure that the refrigerant can circulate freely and ensure that your appliance will work efficiently.
- If possible, place your appliance in a cool, well ventilated dry room.
- Do not place your appliance in direct sunlight, nor in a room at high temperature.
- Do not place your appliance in the vicinity of any sources of direct heat such as heating, ovens, hob etc.

If installation near a direct heat source can not be avoided, we recommend fitting at a suitable distance from the heat source

- From a cooker: 3cm
- From an oven: 30cm

Never obstruct the ventilation

Always pull out the plug, not pull the cable when cutting the appliance off from the mains supply.

**Warning: Leave the appliance standing in its final position for at least 12 hours before switching it on, so that the circulation of the refrigerant stabilizes and no operational problems occur. Before connecting up the appliance, make sure that it is absolutely dry inside.**

**Warning: Depending on its composition, the refrigerant can be easily inflammable, the refrigerant circuit has been hermetically sealed and has been tested many times for possible leaks.**

**Any interference might well create a fire hazard. Make sure nothing mechanically effects the circulation of the refrigerant, in particular the accessible parts around the compressor.**

**Only a qualified professional should intervene with refrigerating systems. Any refrigerant spilling out can injure your eyes. In the event of eye contact with the refrigerant, wash your eyes immediately with plenty of water and consult a doctor immediately.**

The appliance according to its climate category, is meant for use at certain room temperatures lower than 38°C

#### 4. Rating plate

The rating plate with the technical data is located on the side of the appliance inner or outside, on the rear side of the unit. Take a note of the technical data

Copy below the technical data from the rating plate so that it is easily accessible without having to move out the appliance.

- Model number:-----
- Gross capacity:-----
- Net capacity:-----
- Operation voltage:-----
- Maximum input power:-----
- Safety fuse:-----
- Energy consumption:-----
- Freezing capacity:-----

#### 5. Connecting your appliance to the mains

Your appliance must be connected only to an earthed power socket which complies to relevant standards and has been installed by an authorised specialist. Before you plug in your appliance to the power socket, make absolutely sure that the voltage and the safety fuse for the main fuse box stated on the appliance rating plate match your electrical supply. If these do not match, please notify the Caple service department or your dealer immediately. The appliance must not be connected to an inverse rectifier (i.e. solar panels)

#### 6. Using your appliance

Switching on / off and selecting levels on the thermostat

##### To switch on:

Turn the temperature dial to the right

The appliance has been switched on.

The compressor is activated until the set temperature inside the appliance has been reached.

The temperature must be set according to:

- The appliance's room temperature
- Quantity of the food
- How often the appliance is opened

We recommend a medium setting. You will soon learn, through observation, which is the most suitable setting for your requirements.

##### Switching off:

Turn the dial as far to the left as possible, the compressor will then switch off

#### 7. Starting up the freezer

1. Switch on the freezer by turning the temperature dial to the right
2. If equipped with a super freeze switch, turn it on.

3. Do not open the door of the freezer compartment for about 4 hours, so that the temperature in the freezer can drop to the necessary level.
4. You can now fill the freezer with any amount of frozen food (Food which has been bought ready frozen).
5. If you want to freeze fresh, chilled food, consult the chapter "freezing / storing fresh food".

##### Warning:

- Do not store any bottle liquids in the freezer. Liquids expand when frozen and the bottle may explode.
- Never keep explosive substances or aerosol cans with inflammable propellants such as butane, propane, pentane etc. in the freezer. Any escaping gases could be ignited by electrical components. Such aerosol cans can be recognized by the list of contents or by the inflammable symbols printed on the can itself.
- When storing ready frozen food, you must follow the manufacturer's instructions on the food packaging.
- Deep frozen ice-cream must not be eaten until a few minutes after being taken from the freezer to avoid injury to lips and tongue. For the same reason, avoid touching the frozen inside walls of the freezer with wet hands.
- Defrosted or slightly frozen products should be used immediately. As a rule, such products are not suitable for re-freezing.
- Packaging should be dry to avoid things freezing together.
- Ready frozen foods should be stored so that they do not come into contact with newly added foods which have not yet frozen.

#### 7. Instructions for the fridge

Relevant instructions can be found in one of the following chapters.

#### 8. Freezing / Storing fresh food

Almost all fresh products are suitable for freezing and storing in the freezer. For the most common of these products, a storage guide with details of acceptable storage times and the most suitable packaging is provided.

Label fresh products clearly as they are not easy to identify when deep frozen in transparent freezer bags. We recommend using commercially available labels for frozen foods.

Pack fresh products in portions suitable for your needs to avoid defrosting quantities that are too big for you to use up in one day. Label the portions with at least the following information Product name, weight of the portion, quantity, freezing date and best date for using.

Then continue as follows:

a) Berries, fruits with peel, herbs etc. should be laid out loose for freezing in the freezer drawer and then put into freezer bags after about 12 hours. Store the filled freezer bags in one of the available drawers. Fresh food should be placed in the top drawer and moved down to one of the lower drawers after approx 24 hours. Avoid putting fresh foods directly in contact with deep frozen food. The deep frozen food could defrost and may not last out the normal storage time.

b) Within a period of 24 hours fill up the freezer only with the adequate quantities of fresh food for the freezing capacity of your freezer. (Consult the information on the rating plate)

c) If your freezer is equipped with a super freeze switch, switch it on. This is not strictly necessary when filling up with already frozen foods.

**Warning! Switch off the super freeze switch after 24 hours at the latest.**

d) Set the temperature dial to a medium to high setting.

e) Keep the temperature in the freezer under control preferably by placing a suitable thermometer with a scale range of up to -26. The storage temperature must always be at least -18

#### Refilling the freezer compartment with fresh foods

Make sure that you wait at least 24 hours before refilling with fresh food, in adequate quantities for the freezing capacity of your freezer.

#### Maximum capacity

In order to ensure correct storage of frozen food, never fill the drawers up to the top.

Set the temperature dial strictly according to the filling capacity. To save energy in normal room temperatures we recommend setting the temperature dial to a medium setting.

#### Storage time

The storage time for ready deep-frozen products depends on the type of the products and on its ingredients. For this reason, you should strictly follow the producer's instructions on the packaging.

When you want to freeze fresh foods yourself, consult the FOOD STORAGE GUIDE AT THE BACK OF THIS MANUAL. Once frozen foods have been defrosted, they should be used up within 12-24 hours.

**Do not eat any food beyond its storage time, this could lead to food poisoning.**

#### Precautions and advice

- Whenever cleaning or defrosting remove the power plug or switch off the main fuse.
- After closing the freezer door, do not open it immediately and do not force it open under any circumstances. The vacuum created by the sealing of the door is dispersed after about 1-2 minutes, so that the door can be opened normally again.
- To prevent condensation and ice forming, allow cooked food to cool down to room temperature before closing the lid of the dish and before storage.
- Leave the freezer door open as briefly as possible to avoid wasting energy and to prevent an excessive amount of ice forming in the freezer.
- Never use a screwdriver or any other sharp edged metal tool to remove the layers of ice. The inside walls are very delicate and can be easily damaged by sharp edges. Use only plastic or wooden scrapers with no sharp edges.

#### 9. Cleaning and maintenance

**As a firm rule, unplug the power plug or switch off at the mains before any cleaning or maintenance.**

For the upkeep of the external appearance of your fridge freezer, clean the outside every now and again with furniture polish or with an enamel protecting product. Clean the door seal with warm water but do not use any cleaning products. Clean your appliance regularly.

- The various parts inside the fridge freezer are generally not suitable for cleaning in a dishwasher. These should be **washed by hand with warm water and a little washing up liquid. Never use the cleaning agent neat and on no account use any abrasive or acid, i.e. chemical cleaning agent is not recommended.**
- The rating plate should not be damaged and should never be removed, this is essential for servicing. Make sure when cleaning, that no water runs onto any electrical parts inside the appliance.
- If there is a heat exchanger, called condenser, on the back of your appliance, this should be cleaned regularly. Dust and dirt impede the release of heat from the inside and considerably increase energy consumption. For best results, use a soft brush or a duster to remove dust from the condenser.

#### Special tips for cleaning the fridge

Clean the drain hole in the fridge from time to time with for example, cotton buds, in order to keep it clear.

### Switching off the appliance

If your appliance is going to be switched off for longer periods, the doors should be left open to prevent odours from building up inside. If your appliance has a lock, set the lock in the "closed" position with the doors open and keep the key well away from small children to prevent accidents.

Ice and frost layers which build up to a certain thickness on the inside wall act as insulation and prevent the dispersion of the coldness. These must be removed from time to time. To remove the layers of ice from the inside walls, use a plastic or wood scraper with no sharp edges. When doing this, remove the drawers and lay a cloth on the bottom of the appliance to catch the ice as it is scraped off so that it can be easily removed.

The method least likely to damage your appliance when removing the layers of ice is to defrost it.

### Defrosting

In normal circumstances the product should be defrosted by its own system, which is automatic.

### Danger Warnings:

**Never use electrical appliances to defrost your appliance, such as a hair dryer, fan heater, dehumidifiers, de-icing sprays or anything with a naked flame.**

**The plastic inside of your appliance could melt and the escaping gas or foam could be ignited by sparks or by the naked flame**

**On no account should a steam cleaning device be used to defrost the layers of ice in the appliance (great risk of an electric shock)**

Proceed as follows to defrost your appliance

1. Provide a suitable non-metallic container
2. Make absolutely sure that you remove the plug from the power socket.
3. Dry your hands thoroughly to prevent skin damage from the contact with ice
4. Remove all frozen food from the freezer and roll it firmly in newspaper place it in the container already prepared and place the container in a cool, dry room.
5. Cover the container all around with a thick blanket.
6. Remove the drawers by pulling them as far out as possible and then raising them slightly.

7. As described previously, scrape the thickest ice carefully from the freezer and put it in the kitchen sink.

8. If your appliance is equipped with a drip duct at the bottom, pull it out and place a bowl to catch the dripping water underneath.

9. If necessary, speed up defrosting by placing a large bowl of warm water on the bottom of the appliance and close the door.

10. If your appliance is not equipped with a drip duct, place an absorbent cloth underneath the front of the appliance and wipe up the defrosting water with a sponge.

11. Thoroughly clean the inside, wipe it out with warm water and a little vinegar and then rinse it out with clear water.

12. Dry it thoroughly with a soft cloth and air it for 3-4 minutes.

13. Close the door and plug the appliance back in

14. Reset the temperature dial to the maximum setting.

15. Now refill the drawers with the frozen food, the oldest items at the top.

**To prevent the frozen food from defrosting, carry out the steps described above within two hours at the most.**

## 10. Using the fridge

### Switch on / off and selecting the temperature

The appliance is switched on automatically when it is plugged in and the power is switched on.

### Temperature settings:

Turn dial left to Lowest setting = slight cooling

Turn dial right to highest setting = lowest temperature. The temperature must be set according to :

- Room temperature
- Quantity of stored foods
- How often the appliance is opened

We recommend a medium setting. You will soon learn, through observation, which is the most suitable setting for your requirements.

### Internal lighting:

For those models equipped with internal lighting, a switch has been built in. When the fridge door is opened, the LED light automatically comes on and automatically goes off when the door is closed. The light bulb is protected by a transparent cover. If the LED lights were to fail please contact Caple Service to arrange for the light fixing to be replaced.

When replacing the light bulb, follow the instructions given on the separate sheet or the illustration on last page of this user manual.

**Changing the light bulb: (for non LED lights)**

Never use a stronger light bulb than indicated above. The voltage indicated on the bulb must, in any case, comply with the relevant data marked on the rating plate of your appliance.

- Unplug the appliance from the main fuse.
- Remove the transparent lamp cover
- Remove the old bulb by unscrewing it and screw in the replacement bulb.
- Fit the lamp cover back in place.

**Temperature range:**

Thanks to the natural air circulation in the fridge there is a range of different temperatures which are suitable for the storage of different foods. The coldest areas are directly over the salad crisper, in the lowest part of the fridge and against the back wall, the warmest areas are in the front upper part and on the door.

Arrange the foods according to the following table and store it not too tightly packed so that the air can circulate freely. **Storing**

**food in the fridge (from the top to the bottom)**

1. Door storage compartments
  - a) Butter, cheese
  - b) Eggs
  - c) Small jars or bottles, tins, seasonings
  - d) Larger bottles, tins
2. Fridge compartment(shelves and crisper)
  - a) Preserves
  - b) Pastries, ready cooked foods
  - c) Dairy / meats and sausages
  - d) Vegetables, fruits and salad
    - Food which gives off or absorbs odours should be stored in sealed containers or the suggested packaging shown on pg8
    - Vegetables, fruits, salad can be stored unpacked in the salad crispers.
    - Plastic and aluminium foils which can be reused, are suitable for packing food, as are metal or glass containers.
    - Hot foods and drinks should always be allowed to cool down out of the fridge.

**11. Troubleshooting guides:**

High quality manufacturing processes and the use of latest refrigerating and freezing technology will basically ensure the trouble free functioning of your appliance. If you suspect any fault, before contacting your nearest Caple service department directly or via your dealer, make sure that you have followed all instructions and advice given in this user manual.

Please note:

The compressor must not operate continuously. It is controlled by a thermostat with which you set temperatures. It is perfectly normal to hear noise from the compressor when the refrigeration system is running.

In unheated rooms and in cold weather conditions, condensation can build up on the outer walls of the appliance. This does not mean there is fault and it will disappear when the temperature increases.

Only call the service department if after analysis of the possible fault factors, you can not find any cause for the defect or you are able to eliminate the fault. Call Caple Service on 0844 800 3830 or email [service@caple.co.uk](mailto:service@caple.co.uk)

- a) The appliance does not function ( it is not running)
  - Is the plug in good order and is it plugged in the socket properly?
  - Is the electricity coming through? (check this by possibly plugging in a small appliance)
  - Is the appliance switched on? ( temperature dial should not be set to " 0 " )

**In the event of a fault or of a power failure, the insulation of the appliance walls provides 2 to 5 hours storage time for the frozen foods after the beginning of such failures.**

Considerably more time is granted in specially insulated appliances. Ask your dealer what is the relevant "Storage time in an emergency."

If it takes longer to eliminate a problem, the frozen food in the appliance begins to defrost. Therefore, take prompt action to eliminate the problem and if necessary, move the frozen food to another freezer (perhaps to another refrigerator)

b) Your appliance is not cooling sufficiently. The freezing process is taking too long and the compressor is running too often

**Please check:**

- Did you make sure that the fridge freezer was left to stand for at least 2 hours before switching it on? ( To stabilize the circulation of the refrigerating fluid) see " starting up" unplug your appliance and lift it to one side, with the door closed, for a short while, i.e. tilt it and then place it back down on its feet again. After 12 hours plug it back in. Do not open the door again for about 12 hours.

The door does not close tightly and it not sealing properly.

Test: place a sheet of paper between the seal and the casing and close the door. It should be difficult to pull out the paper on

One or more sides, call your nearest service department.

- Heavy ice forming on the inside walls of the freezer ( see “ cleaning and maintenance”)
- The appliance is exposed to direct sunlight or it sited near a direct heat source.
- Protect the appliance against direct sunlight / check the distance from the heat source / place an insulation plate between the appliance and the source of heat. ( see “ choosing where to install your appliance” )
- The freezer has been filled up with a quantity of fresh food which does not comply with the freezing capacity indicated on the rating plate
- Is the ventilation working properly, the ventilation grille covered or it the condenser on the outer rear wall full of dust?

**c) Your appliance is excessively noisy:**

**Please check:**

- Is the cabinet standing level and steady? Are any nearby objects or items of furniture being vibrated by the cabinet? Make sure everything at the rear is free, carefully bend back any parts touching.

Note: Slight bubbling noises are normal for this type of refrigeration system.

**Warning:**

**On no account should you undertake any technical interventions or attempts at repair on your appliance.**

**12. Getting your appliance serviced:**

**Any repairs or interventions on the appliance should only be carried out by your nearest Caple service department, otherwise the user may run considerable risks and the guarantee may no longer be valid.**

Consult the enclosed guarantee card or contact Caple Service on 0844 800 3830 to see which service centre is responsible for servicing your appliance.

**Repairs by the service department** to eliminate faults which have occurred because of non-adherence to the information and advice given in this user manual, a cost will be charged to the customer as this is not covered by the guarantee.

In order to receive immediate help, make sure your have ready the following essential data to identify your appliance.

- Model number and serial number (see rating label)
- Date of purchase
- Name and place of your dealer
- Description of the fault

**13. Guarantee:**

The general terms and duration of the guarantee are those stated on the guarantee card. Also see the inside back cover of this manual.

**14. Building in the appliance**

Relevant instructions are included among the other appliance documentation. These must be followed to ensure correct operation.

**As these products are subject to continual improvement, they are subject to change without prior notice.**

## STORAGE TABLE

Fresh food		Suitable packaging		Approx. Storage time in weeks				
				2-3	4	6	8	10-12
Mince meat	>	Polyethylene bag	>	●				
Sausages	>	Polyethylene bag	>	●				
Small fish	>	Polyethylene bag	>	●				
Heart / liver	>	Polyethylene bag	>	●				
Ice cream	>	Plastic container	>	●				
Fruit	>	Plastic container	>	●				
Cheese	>	Polyethylene bag	>		●			
Bread	>	Polyethylene bag	>		●			
Large fish	>	Polyethylene bag	>		●			
Cake / Biscuits	>	Glass container	>		●			
Pork	>	Aluminium foil	>			●		
Beef	>	Aluminium foil	>			●		
Lamb	>	Aluminium foil	>			●		
Mushrooms	>	Polyethylene bag	>			●		
Asparagus	>	Polyethylene bag	>			●		
Vegetables	>	Polyethylene bag	>			●		
Strawberries	>	Polyethylene bag	>			●		
Flans	>	Aluminium foil	>			●		
Chicken	>	Aluminium foil	>				●	
Turkey	>	Aluminium foil	>				●	
Duck	>	Aluminium foil	>				●	
Goose	>	Aluminium foil	>				●	
Cauliflower	>	Polyethylene bag	>					●
Beans	>	Polyethylene bag	>					●
Pepperoni	>	Polyethylene bag	>					●
Preserves	>	Glass container	>					●
Preserved fruit	>	Glass container	>					●
Ice Lollies	>	Aluminium foil	>					●

Note: The above data are only for reference, and not suitable for all occasions.

# Refrigerator Diagram

---

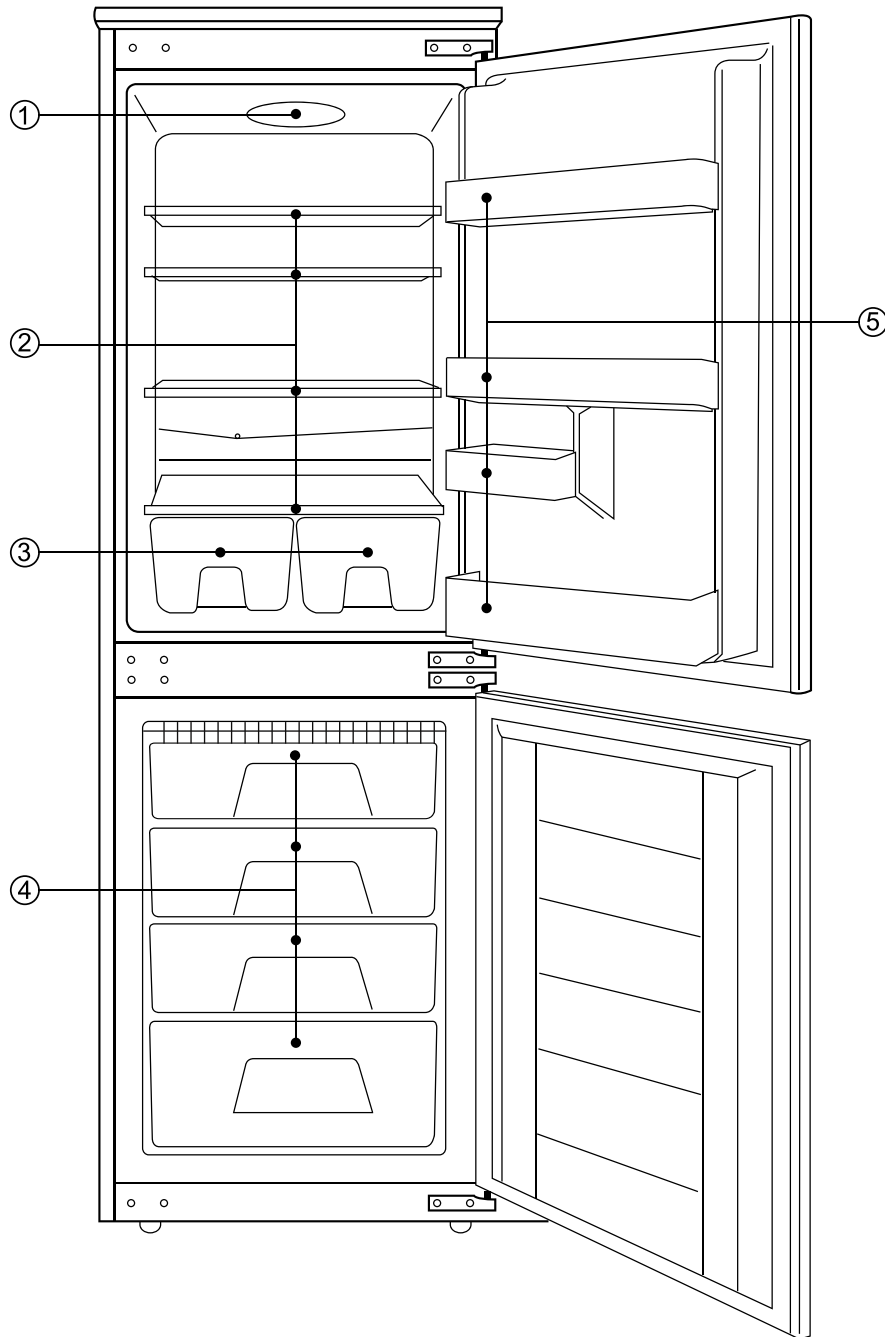

- ① Control panel and lamp
- ③ Fresh food container
- ⑤ Bottle holder

- ② Food shelf
- ④ Drawers

*This diagram may vary slightly with the layout of the refrigerator you have just purchased due to technical improvements.*

# Installation guide

# Positioning and installing the appliance

1. Once the appliance has been unpacked, check the main voltage is the same as that indicated on the rating plate.
2. If the door opening direction is as required, continue with the installation. Otherwise, reverse the position of the hinges. To do this, carefully follow the guide on page 7

## **When installing the appliance, remember the following:**

- A. Do not install the appliance near any sources of heat such as heaters, radiators, ovens, cookers, etc. or in direct sunlight.
- B. Make sure that during the automatic defrost, any water on the back wall of the compartment runs into the drain channel.
- C. After the appliance has been placed in its final position, leave it for at least 12 hours before connecting it to the power supply.
- D. Make sure that the appliance is working correctly before placing any food in it.

**WARNING: DO NOT INSTALL THE APPLIANCE NEAR TO ANY HEAT SOURCES AND LEAVE A GAP OF AT LEAST 5 CM ABOVE IT.**

## **INSTALLATION IN THE TALL UNIT HOUSING**

The dimensions of the tall unit housing must correspond to those illustrated on pages 4 and 5.

Insert the appliance in the housing against the side panel adjacent to the opening.

Adjust the foot until the top panel is not in contact with the unit, and anchor the upper part of the appliance, using the screws supplied, in the pre-drilled panel over the front fascia. Anchor the two bottom brackets to the base of the cabinet and the center of the appliance to the wall of the unit using the special brackets. Fix the two bottom feet in the holes in the base of the unit.

Apply the plastic joint gasket.

Position the door sliders and fix in place. Also clip in the screw cover sections.

Fit and secure the slider blocks to the door.

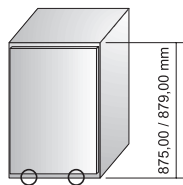
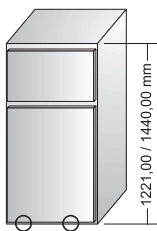
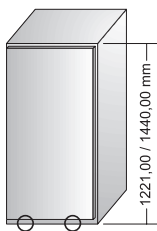
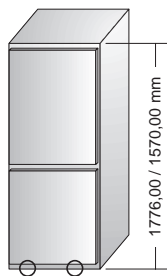
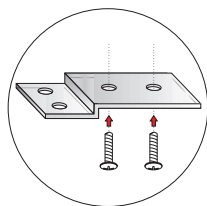

Sealing gasket

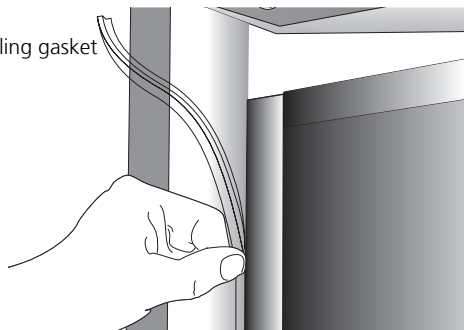

Fill the gap on the non-hinged side with the sealing gasket, as shown in the image to the left.

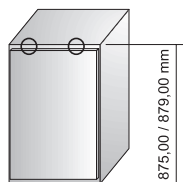
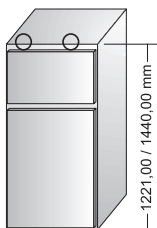
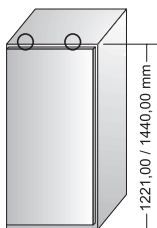
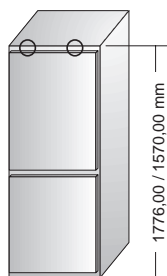
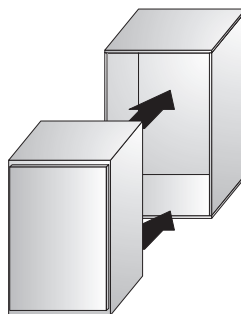
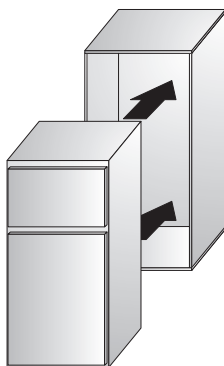
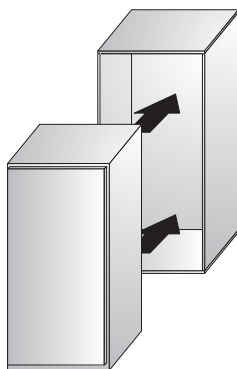
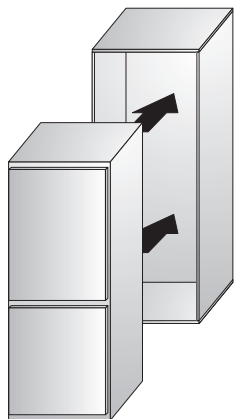

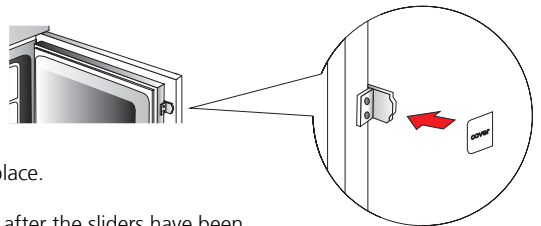
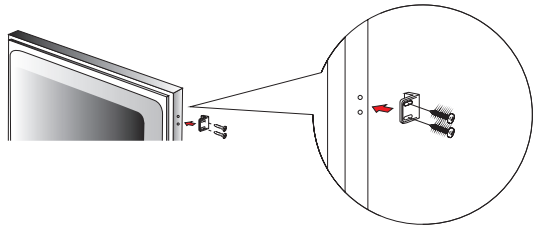
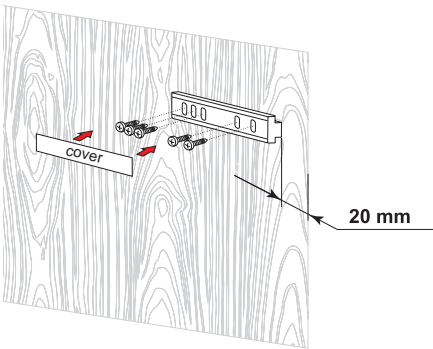
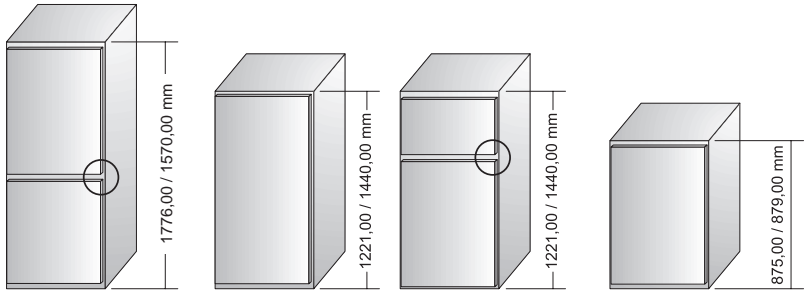
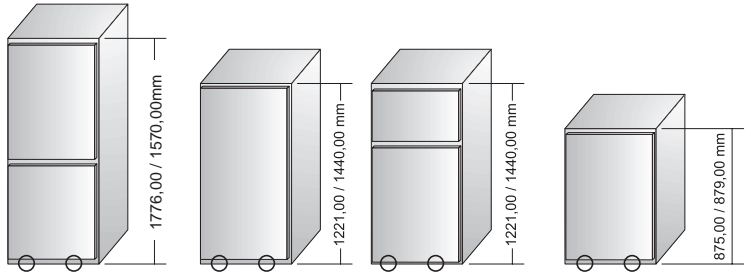
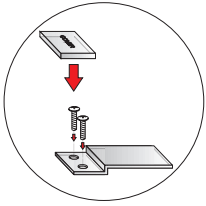

Once the slider has been fitted to the furniture door please add the decorative cover to cover the screw fixings. This simply clips into place.

Tip: It can help if the door slider blocks are fitted after the sliders have been fully fixed to the furniture door and the covers clipped into place.

## Installation dimensions

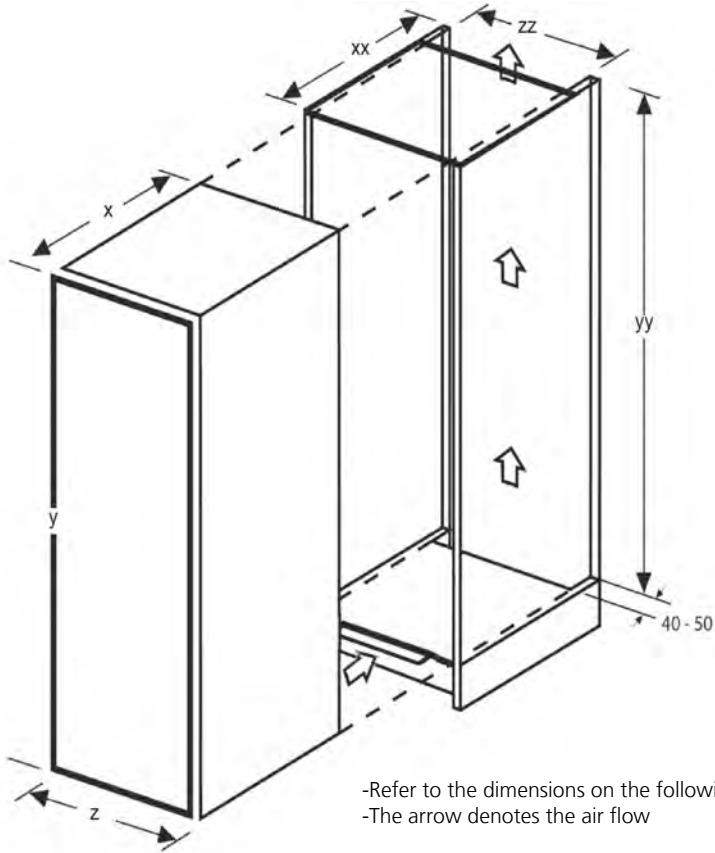

-Refer to the dimensions on the following page  
-The arrow denotes the air flow

## Ventilation

The main consideration when installing a refrigeration product into a cabinet is ventilation. The heat removed from the appliance needs to be dissipated into the room. Failure to correctly ventilate the product can result in increased running costs and premature failure. It will also invalidate the guarantee provided with the appliance.

An air intake in the plinth is required to allow for the correct air flow (recommended 500mm x 40mm). If preferred a decorative stainless steel plinth grille is available, product code: GRILL/SENSE600. This can be purchased from your retailer or [www.caple.co.uk](http://www.caple.co.uk).

To ensure the correct operation of the appliance it is important the top of the housing is not blocked off. The top of the cabinet needs to be vented into the room, the recommended size of the vent opening is 500mm x 40mm.

There should also be space at the rear of the cabinet to allow the cool air to be drawn over the condenser. This should also be at least 500mm x 40mm.

The more air available to circulate the product, the more efficiently it will operate.

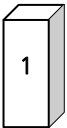
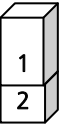
Model	X (mm)	Y (mm)	Z (mm)	XX (mm)	YY (mm)	ZZ (mm)	 / 
RI556/RI558 RI735/RI737	540	1776	540	550-560	1778-1785	560	2
RIR179/RIL179 RIF178	540	1776	540	550-560	1778-1785	560	1
1574	540	1574	540	550-560	1576-1580	560	2
1440	540	1440	540	550-560	1442-1449	560	2
1440	540	1440	540	550-560	1442-1449	560	1
RIF123	540	1221	540	550-560	1223-1230	560	1
RIL124	540	1221	540	550-560	1223-1230	560	1
1020	540	875	540	550-560	1022-1028	560	1
RIL891/RIF89	540	871	540	550-560	873-880	560	1

## Reversing the door opening

1. Before reversing the door opening direction, unplug the appliance and remove all food.
2. Using a flat screwdriver pry and remove hinge caps.
3. Using a Phillips screwdriver remove the door upper hinge while holding the door (Fig. 2).
4. Using a Phillips screwdriver remove the middle hinge while holding the upper door\*
5. Set the door aside in a safe place.
6. Tilt the appliance (up to 40 degrees) so as to have sufficient access to the lower hinge (Fig. 3).
7. Using a Phillips screwdriver remove lower door hinge
8. Attach the lower hinge on the other side (Fig. 4).
9. Position the door assembly in such a way so that pin of the lower hinge is aligned with the appropriate hole of the lower door bracket.
10. Attach the middle hinge on the other side of the appliance so that the lower pin of the middle hinge is aligned with the appropriate hole of the upper door bracket. Position the second door assembly so that the upper pin of the middle hinge is aligned with the appropriate hole of the lower door bracket.\*
11. Attach the upper hinge so that the hinge pin is aligned with the appropriate hole of the upper door bracket.\* (Fig. 5).
12. Check that doors are properly aligned with the appliance body.
13. Replace the hinge caps.
14. Switch on the appliance as described in the relevant section of its operating instructions.

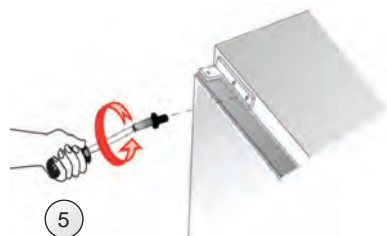
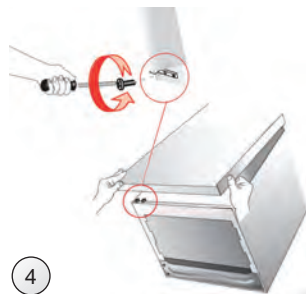
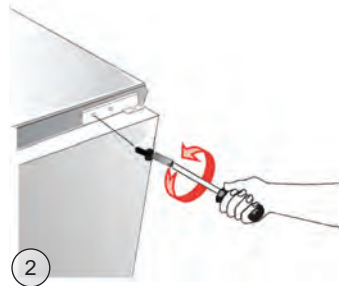

\* This action applies to appliances with both refrigeration and freezer chambers.

## Guarantee

Caple undertake that if within twelve months of the date of the purchase this appliance or any part thereof that is proved to be defective by reason only of faulty workmanship or materials, we will at our option repair or replace the same free of any charge for labour or materials on condition that:

- Documentation must be provided before a guarantee repair commences to confirm that the product is within the guarantee period.
- The appliance has been correctly installed and used only on the electrical supply stated on the rating plate.
- The appliance has been used for normal domestic purposes only, and in accordance with the operating and maintenance instructions.
- The appliance has not been serviced, maintained, repaired, taken apart or tampered with by any person not authorised by us.
- All service work under this guarantee must be undertaken by Caple Service Centre.
- Any appliance or defective part replaced shall become the property of this company.
- If a service call is made and it is found that the installation has not been carried out correctly or customer misuse/abuse is involved THE COST OF THE SERVICE CALL HAS TO BE PAID FOR BY THE USER BEFORE ANY SERVICE WORK IS CARRIED OUT.

## Exclusions

This Guarantee does not cover:

- Damage or calls resulting from transportation, improper use or neglect, the replacement of any light bulbs or removable parts of glass or plastic.
- Costs incurred for calls to put right appliances improperly installed or calls to appliances outside the United Kingdom.
- Appliances found to be in use within a commercial environment, plus those which are the subject of rental agreements.
- This guarantee is in addition to and does not affect your statutory and legal rights.

## Environmental protection

Waste electrical products should not be disposed of with household waste. Please recycle where facilities exist. Check with your Local Authority or retailer for recycling advice.



This appliance is marked according to the European directive 2002/96/EC on Waste Electrical and Electronic Equipment (WEEE).

By ensuring this product is disposed of correctly, you will help prevent potential negative consequences for the environment and human health, which could otherwise be caused by inappropriate waste handling of this product.

The symbol on the product indicates that this product may not be treated as household waste. Instead it shall be handed over to the applicable collection point for the recycling of electrical and electronic equipment.

Disposal must be carried out in accordance with local environmental regulations for waste disposal.

For more detailed information about treatment, recovery and recycling of this product, please contact your local council, your household waste disposal service or the retailer where you purchased the product.

## CE Declarations of Conformity



This appliance has been manufactured to the strictest standards and complies with all applicable legislation, Low Voltage Directive (LVD) and Electromagnetic Compatibility Directive (EMC).