



RI736

Caple integrated fridge freezer

Technical information

Product installation diagrams

Models:
Ri735
Ri736

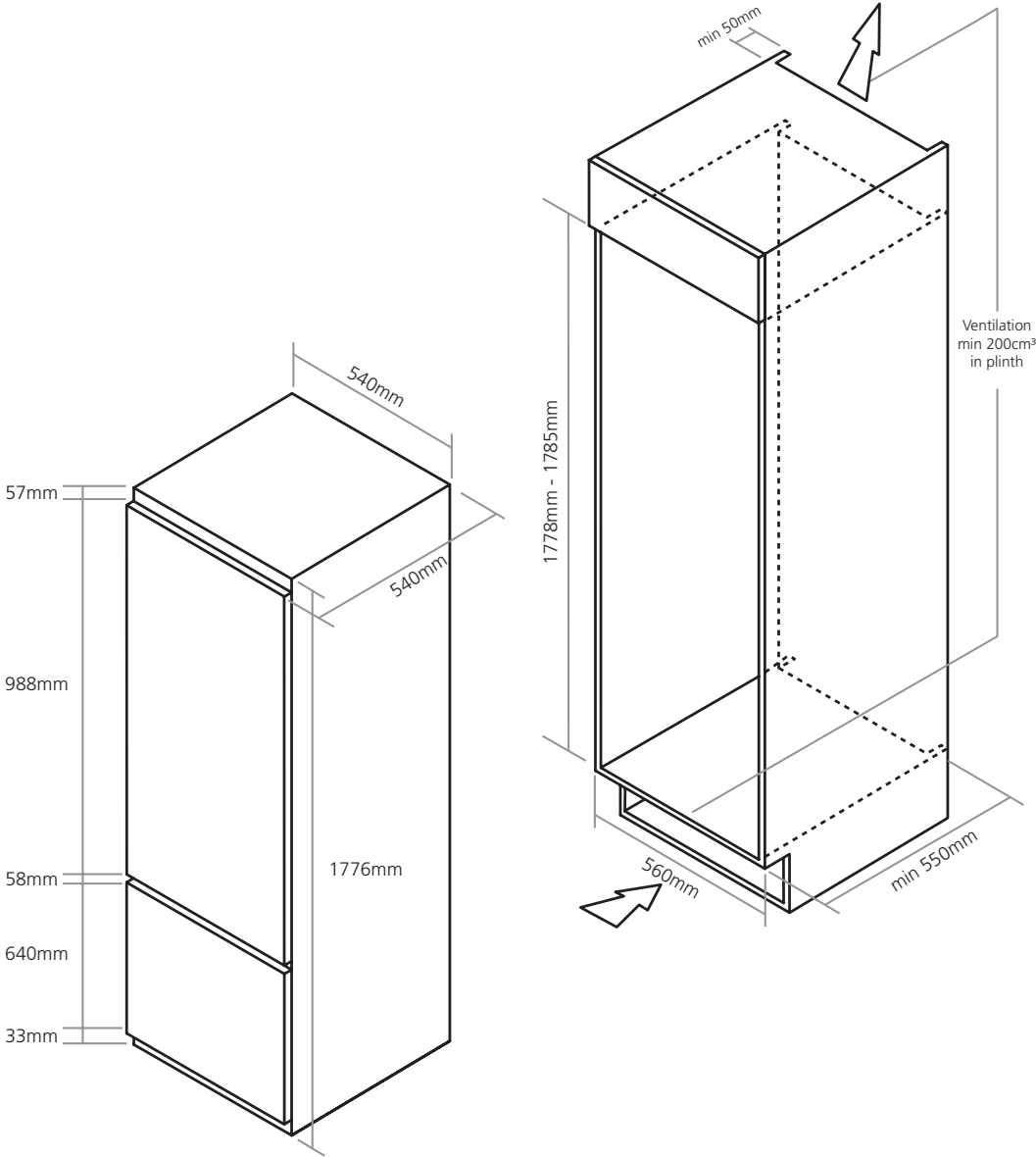



RI736

Capele integrated fridge freezer

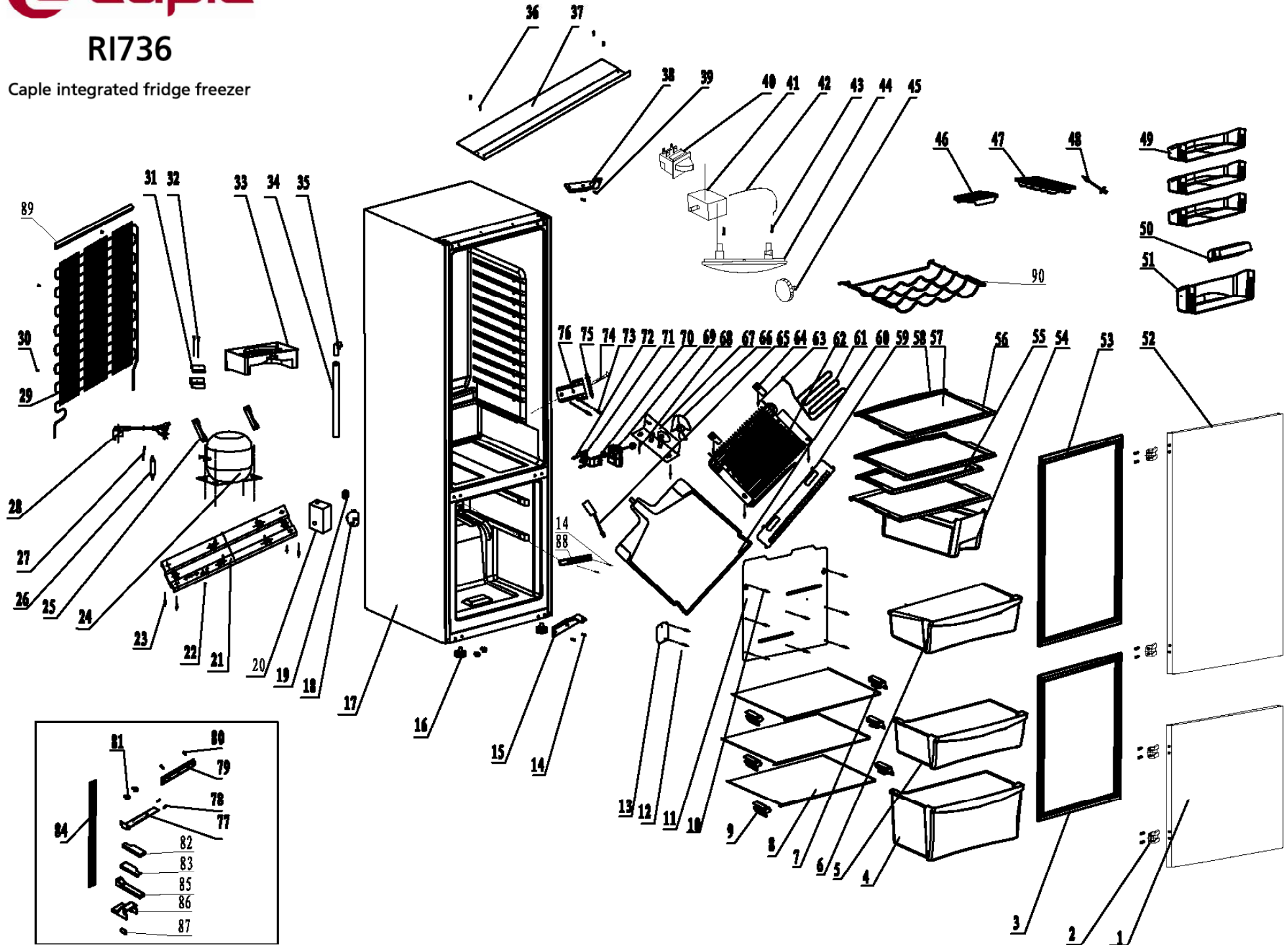



RI736 - Caple integrated fridge freezer

Item	Part Code	Description	Qty
1	2.01.F0TQ02-173	freezer door	1
2	1.06.TQ9G80-105	connecting block	4
3	1.39.200202-173	freezer gasket	1
4	1.03.312142-041	lower drawer	1
5	1.03.210142-041	middle drawer	1
6	1.03.110042-143	upper drawer	1
7	1.06.TQ1671-106	right stopper	2
8	2.24.2114302-01	drawer plate	2
9	1.06.TQ1670-106	left stopper	2
10	1.12.B39160-AB7	self tapping screw	5
11	2.24.1717302-01	air flow cover	1
12	1.12.B39160-AB7	self tapping screw	2
13	2.24.1814302-01	wire box lid	1
14	1.13.G50130-104	Flange Screw	4
15	1.11.03156TQ-03	Lower hinge	1
16	1.06.TQ2170-110	adjustable feet	2
17	2.00.TQ020067-0	foamed cabinet	1
18	1.35.HDD01X-143	defrosting timer	1
19	1.38.04PS027-01	ruber fixer	1
20	1.06.TQ7111-027	wire box	1
21	1.11.04110TQ-01	compressor base	1
22	1.13.C40080-106	grounding screw	2
23	1.13.G50130-104	flange screw	4
24	1.10.12138G-1XX	compressor	1
25	1.11.30069TQ-02	compressor support	2
26	1.46.0400TQ-013	drier-filter	1
27	2.20.B1TQ00-000	charging pipe	1
28	1.28.DD2024-143	power wiring	1
29	1.09.3651TQ-173	condenser	1
30	1.12.B42160-AB4	self tapping screw	4
31	1.06.TQ2780-041	power wiring fixer	1
32	1.13.Y40160-104	Y style screw	2
33	1.06.TQ4421-051	water disposal pan	1
34	1.06.TQ1371-173	drain pipe	1
35	1.06.TQ3171-143	drain pipe connector	1
36	1.13.T05016-104	flange screw	4
37	2.24.0710602-01	up hinge board	1
38	1.11.01156TQ-03	up hinge	1
39	1.13.G50130-104	flange screw	2
40	1.29.11X101-000	Lamp switch	1



RI736 - Caple integrated fridge freezer

Item	Part Code	Description	Qty
41	1.32.2513X1-1TQ	therostat	1
42	1.36.DTQ201-105	thermostat wiring	1
43	1.12.B40250-AB7	self tapping screw	2
44	1.30.5G3103-085	lighting	1
45	1.06.TQ0310-085	Tem.control knob	1
46	1.06.TQ0472-041	egg shelf	1
47	1.46.1400TQ-001	ice box	1
48	1.06.TQ7521-037	cleanser plug	1
49	1.06.TQ0674-015	door shelf A	3
50	1.06.TQ2270-105	small door shelf	1
51	1.06.TQ0873-015	door shelf B	1
52	2.01.R0TQ02-105	refrigerator door	1
53	1.39.201102-105	fridge door gasket	1
54	1.06.TQ2371-105	crisper	2
55	1.42.24TQ39-110	safy glass B	1
56	1.06.TQ1911-106	shelf back liner	5
57	1.42.23TQ39-110	safy glass A	4
58	1.06.TQ1910-106	shelf front liner	5
59	1.06.TQQT70-143	air flow cover	1
60	2.01.T0TQ02-143	drain water tray	1
61	1.31.D2940X-173	defrost heater	1
62	1.06.140000-143	freezer evaperator	1
63	1.12.B39160-AB7	self tapping screw	4
64	1.11.67173TQ-01	FZ evaperator fixer	2
65	1.35.WDD01X-143	temperature limiter	1
66	1.06.TQ7511-027	Wind leaf	1
67	1.06.TQ4971-143	motor fixing plate	1
68	1.12.B39160-AB7	self tapping screw	1
69	1.33.DTQ431-027	Fan motor	1
70	1.38.04PF027-01	fan motor fixing bracket	2
71	1.11.61TQ143-01	motor fixer	1
72	1.12.B39160-AB7	self tapping screw	2
73	1.13.G50200-104	Flange Screw	2
74	1.11.82105TQ-06	Connecting pin1	1
75	1.11.83156TQ-01	middle hinge axis	1
76	1.11.02156TQ-01	middle hinge	1
77	1.11.82105TQ-05	Connecting pin	2
78	1.13.G50130-104	Flange Screw	2
79	1.11.76105TQ-03	Connectinig plate	4
80	1.12.B39160-AB5	Self Tapping Screw	20
81	1.06.TQ2620-142	screw hole cover	4
82	1.06.TQ3270-156	up hinge cover	2
83	1.06.TQ3271-156	lower hinge cover	2
84	1.06.TQ1191-105	ornament	1.8米



RI736 - Caple integrated fridge freezer

Item	Part Code	Description	Qty
85	1.06.TQ3273-105	connect pin cover	1
86	1.06.TQ3272-105	middle hinge cover	1
87	1.06.TQ2670-000	top plate hole cover	4
88	1.11.82156TQ-03	Connecting pin	1
89	1.06.TQ9591-117	condenser protective frame	1

