



Instruction manual for wall chimney hood

Model code: ZA800, ZA801



Contact Caple on 0117 938 7420 or for spare parts www.caple.co.uk

GB



The symbol on the product or on its packaging indicates that this product may not be treated as household waste. Instead it shall be handed over to the applicable collection point for the recycling of electrical and electronic equipment. By ensuring this product is disposed of correctly, you will help prevent potential negative consequences for the environment and human health, which could otherwise be caused by inappropriate waste handling of this product. For more detailed information about recycling of this product, please contact your local city office, your household waste disposal service or the shop where you purchased the product. This appliance is marked according to the European directive 2012/19/EC on waste electrical and electronic equipment (WEEE).

Warnings

Uses

Installation

Working

Timing

Maintenance

* The appliance is not intended for use by young children or infirm persons without supervision. Young children should be supervised to ensure they do not play with the appliance.

* The air sucked can't be conveyed through or into a duct used to let out fumes from appliances fed by energy other than electric power (eg. centralized heating, radiators, water-heaters, etc.).

* To evacuate the air outlet, please comply with the pertaining rules given by competent authorities.

The cooker hood, when evacuating the sucked air, could generate a negative pressure in the room- which can't exceed the limit of 0.04 mbar, in order to avoid the suck of exhausts deriving from the heat-source.

Therefore the room should be provided with air-intakes to allow a constant flow of fresh air.

* When performing the electrical connections on the appliance, please make sure that them current-tap is provided with earth connection and that voltage values correspond to those indicated on the label placed inside the appliance itself.

* Please disconnect the appliance from power mains, before carrying out any cleaning or maintenance operation.

If the appliance is not equipped with a nonseparable flexible cable and plug, or with another device ensuring omnipolar disconnection from the mains, with an opening distance between the contacts of at least 3 mm, then such disconnecting devices must be provided in the fixed installation.

If the appliance is equipped with a power cord and a plug, it shall be placed in such a way that the plug can be reached easily.

* The use of materials which can burst into flames (flambé) should be avoided in close proximity of the appliance.

When frying, please pay particular attention to fire risk due to oil and grease.

Being highly inflammable, fried oil is especially dangerous. Do not use uncovered electric grills.

In order to avoid possible fire risk, all instructions for grease-filter cleaning and for removing eventual grease deposits should be strictly followed.

The appliance is already arranged both for filtering and for suction performances.

In its filtering version (Fig.1), the air and fumes conveyed by the appliance are cleaned both by a grease filter and by an active coal filter, and put again into circulation through the side-grids of the chimney.

In its sucking version (Fig.2), fumes are directly conveyed outside, through an evacuation duct connected with the superior part of the wall or the ceiling. Both coal filter and air deflector are not necessary in this case.

The manufacturer will not accept any liability for damages occurred during the appliance handling/transport and installation operations.

Carefully read the following installation instructions , before installing the appliance.

Check that all the components are not damaged. In case of damages , please contact your retailer and do not carry out installation.

- Use an air exhaust pipe of the shortest possible length , with a limited number of elbows, and made in a certified material .
- Avoid drastic section changes (recommended constant diameter Ø 150 mm or similar surface).
- The manufacturer will not accept any liability for air capacity or noise problems , should the above instructions be ignored. The product will not be covered by our guarantee for problems resulting from failure to comply with the aforementioned instructions.

All of the products have been designed with the possibility to direct the air out-let towards the appliance rear side; in case you choose this option , you will need to remove the no. 10 screws found in the suctioning unit support (fig. 3) , pull the suctioning unit out and rotate it in such a way as to direct the air out-let nozzle towards the appliance rear side (fig. 4); then refit the suctioning unit into place and tighten the screws previously removed.

With the help of the special drilling template (fig. 5A), please drill the holes for the wall brackets .

The rear, lowest part of the appliance shall be placed at the following minimum distance from the cook top.

Secure the wall brackets to the wall, by using the anchors and screws supplied with the appliance (FIG.6 A).

Hook the hood to the wall brackets previously fixed (FIG. 6).

Tighten the two screws into the wall bracket (fig. 7 A) , which are necessary to make the appliance adhere to the wall; then check that the hood is perfectly flush with wall, otherwise act on the screws shown in fig. 7 B, as follows tighten the screw if you need to lift the corresponding side, or unscrew it in case you need to reduce the height.

Carry out the electrical connection, by using the appropriate power cord.

Remove the grease filter in order to reach the appliance inner side. The grease filter is removed by following the instructions given in the maintenance section.

Definitively secure the product to the wall by using the screws provided, as shown in fig. 10.

Refit the grease filter and close the front panel.

Suctioning mode (top air out-let).

Secure the pipe support bracket (fig. 12) to the wall and/or the ceiling , by using the anchors and screws provided, in a position corresponding to the centre of the hood.
Connect the motor air out-let flange to the exhaust hole , by using a suitable pipe.
Place the two decorative pipes on the hood exhaust body ; lift the inner pipe as long as it reaches the bracket; then secure it by using the no. 2 self-threaded screws provided .

Suctioning mode (rear air out-let).

You will need to rotate the suction motor, as shown in the installation section and in fig. 3 and 4, in order to direct the motor air out-let towards the appliance rear side .
Fit the air out-let grid into place on top of the hood (fig. 13). The use of steel decorative pipes is not necessary .

Filtering mode.

Fit the air out-let grid into place on top of the hood (fig. 13). The use of steel decorative pipes is not necessary.
In the filtering version, a charcoal filter shall also be used, as shown in the maintenance section, according to the model.

An air deflector is available as an accessory, in order to direct the air coming out of the motor towards the grids of the steel decorative pipes (fig. 14); the air deflector shall be connected to the motor air out-let with a suitable pipe, which is not supplied with the product.

Mod. SL TC – Glass (dis. 15)

A: Light switch On/Off

B: Reduce speed / OFF motor

C: Luminous telltale

D: ON motor/increase speed

E: 10 – minute timer

The touch control key allows the function desired by touching the relative key. If the electrical power supply to the product SLTC is cut, 15 seconds are needed for selfdiagnostics after the functions are restored. In the meanwhile, its operation may be incorrect.

The saturation of the filter is indicated by the flashing speed indicators.
Press the timer button to reset.

As a result of the new EU65 “Energy label” and EU66 “Ecodesign” regulations issued by the European Commission, which came into force as from January 1st, 2015 , our products have been adapted to comply with these new requirements.

All of the models complying with the energy label requirements, are equipped with new electronics including a timer device for suction speeds control, when the air capacity exceeds 650m³/h.

Internal motor models, with maximum air capacity higher than 650m³/h, are equipped with a timer device that automatically switches the suction speed from 4th to 3rd speed, after 6 minutes operation.

The energy consumption of the appliance in stand – by mode is lower than 0.5W.

An accurate maintenance guarantees good functioning and long-lasting performance. Particular care is due to the grease filter panel.

HOW TO REMOVE THE GREASE FILTER AND THE CHARCOAL FILTER

The grease filter is removed by taking it from the centre hole fig.18, and pulling it out of the hood. The filter is held by magnets.

The charcoal filter is installed directly on the grease filter rear side, by hooking the charcoal filter directly on the grease filter frame.

The grease filter needs cleaning by regular hand-washing or in dishwashers every two months at least or depending on its use. In case the appliance is used in its filtering version, the active coal filter needs to be periodically replaced.

The charcoal filter is removed by removing the grease filter first, following the instructions above, then by pulling its special plastic tongue until it is released from its seat.

The charcoal filter is inserted by following the reverse procedure.

To clean the appliance itself tepid water and neutral detergent are recommended, while abrasive products should be avoided.

The power cord shall be replaced by authorized personnel only.

Substitution of the LED bar:

Using an appropriate tool, remove the LED bar from its seat (refer to Fig. 19), disconnect it electronically using the appropriate connector then substitute it with a LED bar with same characteristics.

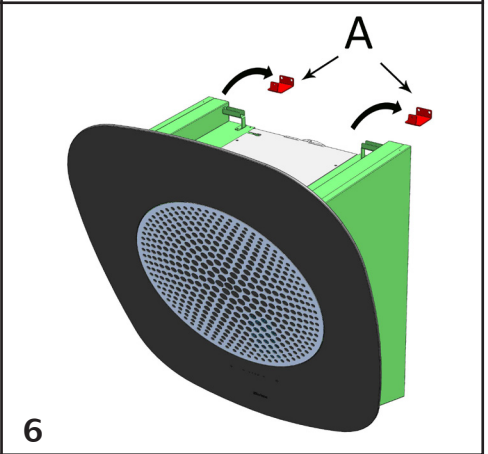
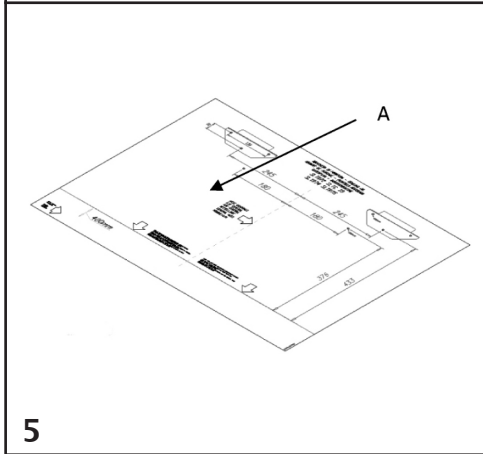
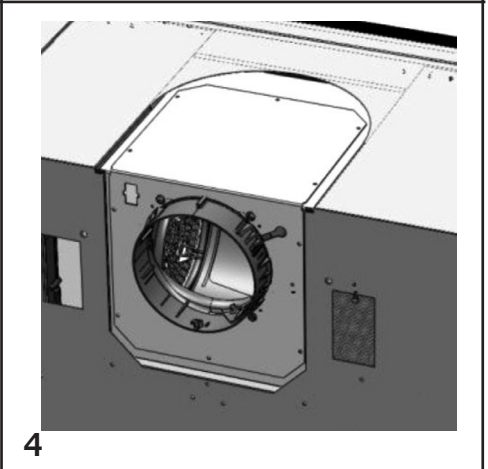
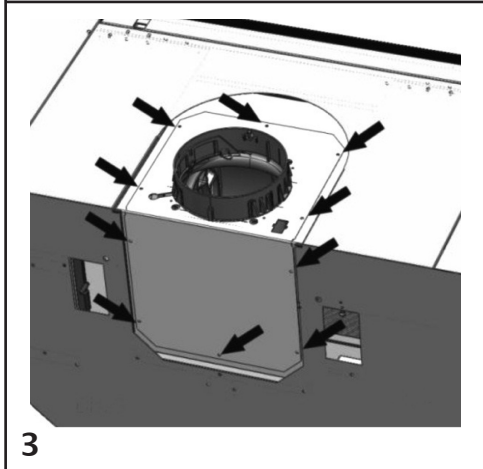
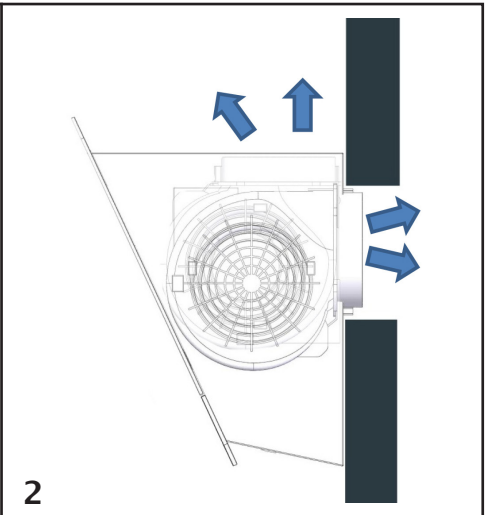
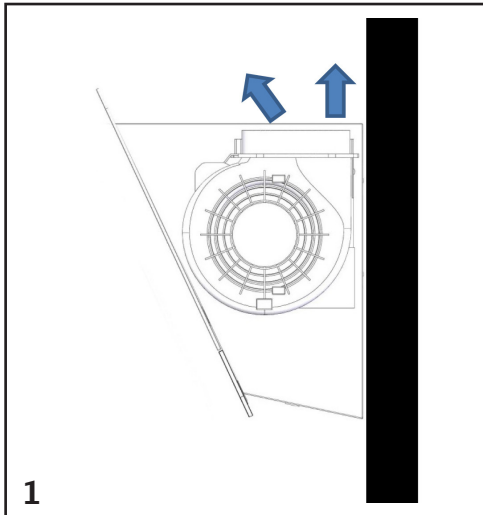

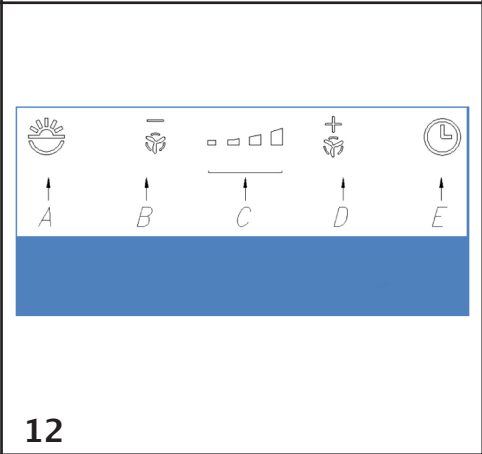
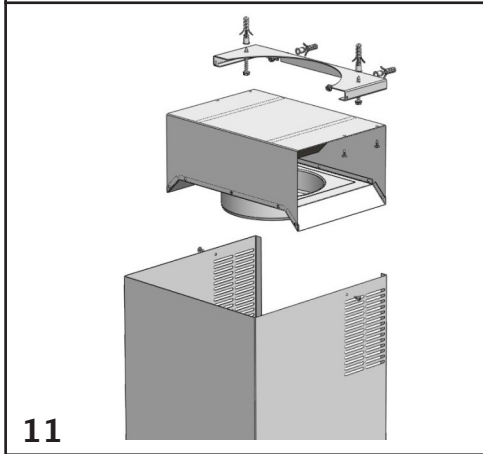
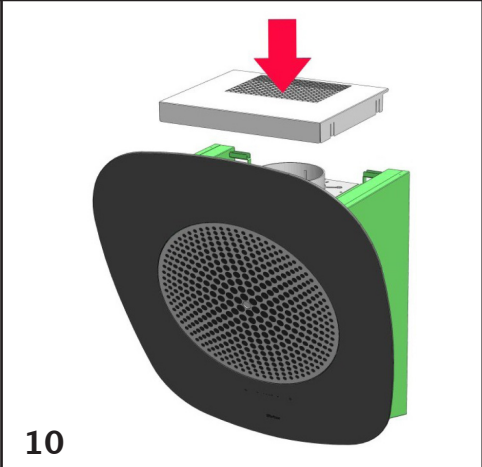
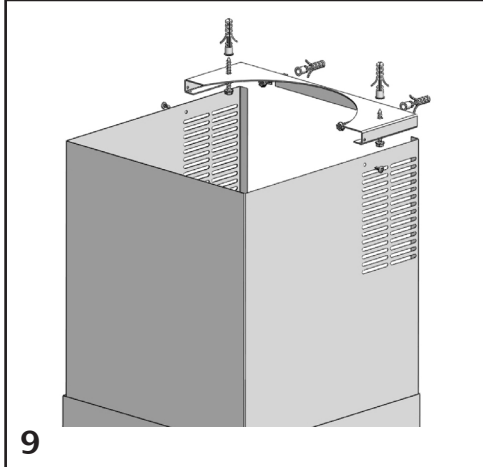
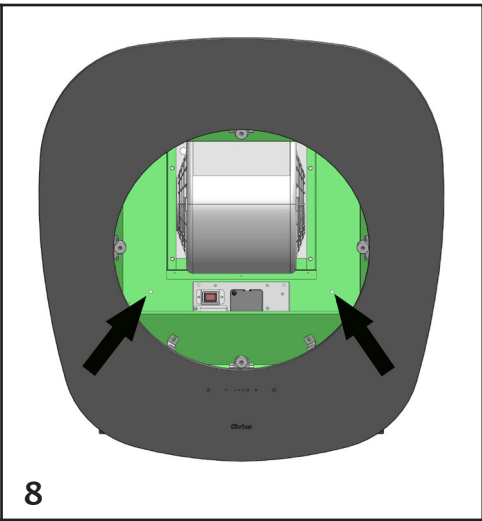
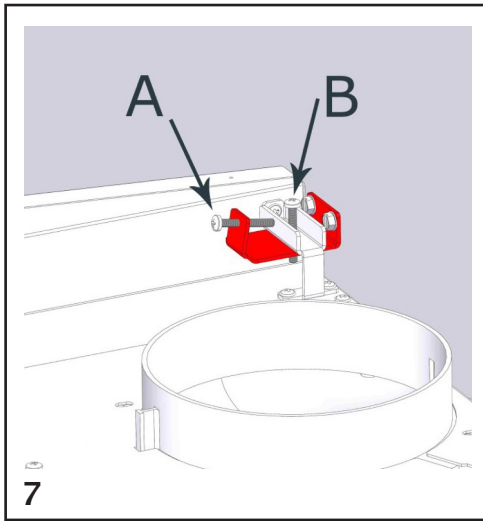

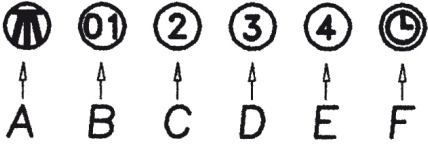

13

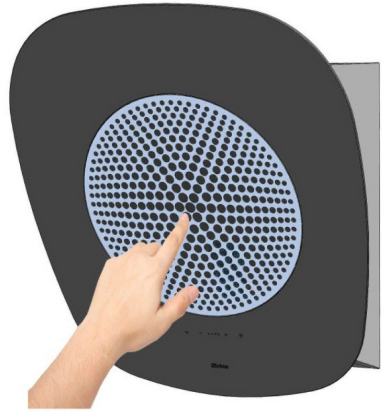

14

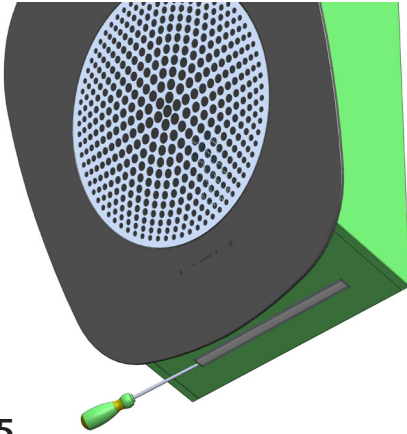

15

Serial number

Caple
Fourth Way
Avonmouth
Bristol
BS11 8DW

www.caple.co.uk

90004220095 – 03/17