

Instruction manual for external motor

Models: DDMEXT20, DDMEXT25
DDMEXT27, DDMEXT30, DDMEXT40



GB



The symbol on the product or on its packaging indicates that this product may not be treated as household waste. Instead it shall be handed over to the applicable collection point for the recycling of electrical and electronic equipment. By ensuring this product is disposed of correctly, you will help prevent potential negative consequences for the environment and human health, which could otherwise be caused by inappropriate waste handling of this product. For more detailed information about recycling of this product, please contact your local city office, your household waste disposal service or the shop where you purchased the product. This appliance is marked according to the European directive 2002/96/EC on waste electrical and electronic equipment (WEEE).

Warnings!

The air outlet of the appliance must not be connected to a flue which is used for exhausting other fumes from appliances, such as a central heating, boilers etc..

For the external exhausting of the fumes, comply with the regulations in force.

Ventilate the room suitably according to the laws in force when the appliance is working together with gas, oil or coal burning appliances, at the same time.

The motor of the peripheral exhausting group is powered by the cooker-hood placed in the kitchen.

Before connecting the cooker hood to the mains supply, make sure that the voltage indicated in the rating plate corresponds to the mains voltage in the home.

Before carrying out any sort of maintenance or cleaning operation, make sure that the appliance is disconnected from the electrical mains.

An appropriate maintenance ensures a good working and a good performance in the long run.

The external motors type DDMEXT are built in class I, therefore they must be earthed.

Useful warnings:

- Use an air outlet pipe with a maximum length not higher than 5 meters.
- Limit the number of bends in the exhausting pipe as every bend reduces the performance up to one linear meter. (If you use 2 90° bends, than the length of the pipe has not to be higher than 3 meters).
- The material for the pipe has to be approved by an authorized company.
- It is important to avoid changes in the diameter (we recommend a diameter of 150mm).
- Read carefully the manual of instructions and installation of the unit.
- Sirius will not be responsible for problems of capacity and/ or noise level due to the missed respect of the warnings included in the manual of instructions.
- DDMEXT25 / 40 are equipped with a 200mm diameter hole for the exhausting pipe. If the unit that has to be connected to the remote fan is already equipped with a 200mm diameter hole, the nit is recommended to use a pipe with the same diameter in order to get good performances. Otherwise, if the unit is equipped with a 150mm diameter hole, than it is recommended to use the joint (from 200mm to 150mm), already supplied with the unit. The electric box cable should not be cut or joined together with other cables, since it could compromise the proper working and the safety conditions of the appliance. Furthermore, this will invalidate the manufacturer's warranty coverage.

CAUTION: In order to know the exact power input in (WATT) of the motor being used, the technician shall tick the box corresponding to the DDMEXT unit used on the label placed next to the rating label, as shown in the figure below. “

 Motor	
DDMEXT20 275W	<input type="checkbox"/>
DDMEXT30 190W	<input type="checkbox"/>
DDMEXT25 250W	<input type="checkbox"/>
DDMEXT27 102W	<input type="checkbox"/>
DDMEXT10 275W	<input type="checkbox"/>
	<input type="checkbox"/>
90005150313	

Warnings!

As a result of the new EU65 “Energy label” and EU66 “Ecodesign” regulations issued by the European Commission, which came into force on January 1st, 2015, our products have been adapted to comply with these new requirements. All of the models complying with the energy label requirements, are equipped with new electronics including a timer device for suction speeds control, when the air capacity exceeds 650m3/h.

DDMEXT20 and DDMEXT30 products have the timer control function activated at IV speed for 6 minutes, if it is combined with a DOWNDRAFT or 5 minutes if it is combined with other products, such as ceiling hoods, wall hoods and island hoods. Once the abovementioned times elapse, the motor will switch to 3rd speed automatically.

DDMEXT40 and DDMEXT25 products have a maximum air capacity higher than 650m3/h at both 4th and 3rd speed, therefore they will have the following by default timer control functions: **DDMEXT40 DDMEXT25 with DOWNDRAFT EM**

4° speed is time controlled for 6 minutes, after which the product switches to 2° speed
3° speed is time controlled for 7 minutes, minutes, after which the product switches to 2° speed
DDMEXT40 and DDMEXT25 with CEILING- WALL AND ISLAND HOODS.

4° speed is time controlled for 5 minutes, minutes, after which the product switches to 2° speed
3° speed is time controlled for 7 minutes, minutes, after which the product switches to 2° speed

The energy consumption of the appliance in stand - by mode is lower than 0.5W.

DDMEXT20 (dis. 1) – DDMEXT25 (dis. 1A)

The appliance is designed to exhaust fumes and odours very silently and in the best way. It must be installed in the house and connected to the cooker-hood, which is in the kitchen (fig. 2).

Types of installation: to make the installation easy, the appliance can be fixed on the wall, on the ceiling or on the floor in a horizontal position (fig. 3) or vertically (fig. 4) to the fixing level.

Note: in the vertical fixing, the brackets supplied can be used only on the longest side (fig. 6).

Installation of the appliance: after deciding the position and the type of installation, insert the anti-vibration rubber caps in the holes of the brackets supplied (fig. 5C).

The rubber caps must be put on the sides which are in contact with the wall.

Put the brackets (fig. 5A) on the remote fitted extraction motor by matching its holes with those of the brackets. Fix with the screws supplied (fig. 5B).

Put the group on the point previously chosen for the installation and mark the points on the wall where the holes must be drilled.

Insert the dowels supplied in the holes (fig. 6A). Put the remote fitted extraction motor on the wall by matching the holes of the brackets with the plastic dowels. Screw with the screws supplied (fig. 6B).

Connection of the pipes: the appliance is endowed with an entrance and an outlet to connect the pipes. Before connecting the exhaust pipes, check the direction of the air showed on the external label (fig. 7). Connect the pipes and fix them with appropriate metal clamps (exhaust pipes and metal clamps have to be supplied by the installer). The pipe (fig. 7A) must be connected with the cooker hood placed in the kitchen, and the pipe (fig. 7B) must be directed outside the building.

Connect the the external motor's cable to the terminal board found inside the plastic box of the wiring . Make sure to respect the colors of cables when performing the electrical connection (fig. 8).

DDMEXT30 (fig. 9)

The appliance was designed to exhaust odours and vapours in the best way. The appliance is to be installed on the outside wall of the house and connected to the cooker-hood which is in the kitchen (fig. 10).

Installation: the mounting of the appliance is to be made by qualified technicians. Using the appropriate drilling jig (fig. 11) drill all the holes marked on it into the external wall, by paying attention not to damage water pipes or power lines.

The holes on the wall are to be drilled with a 8 mm. bit. Insert, step by step, the following parts in the holes drilled:

- the corresponding plastic dowels supplied (fig. 11A)
- the two telescopic pipes in the hole of 160 mm.
- the plastic pipe of 40 mm. diameter.

Before leaning the appliance against the wall, insert the supply cord in the plastic pipe. Fix the appliance without the stainless steel external body, which was previously removed from the motor block, by matching the holes of the motor block with the holes on the wall. Tighten with the screws supplied (fig.11B).

Connection of the pipes: the appliance is endowed with an air entrance to be connected with the telescopic pipes and an air outlet.

After fixing the appliance on the external wall, connect the two telescopic pipes, which are placed inside the wall, with the cooker-hood through the flexible pipes (fig. 12).

The fixing between the pipes have to be made with appropriate metal clamps (pipes and clamps are supplied by the installer).

Electrical connection to the hood:

Connect the the external motor's cable to the terminal board found inside the plastic box of the wiring . Make sure to respect the colors of cables when performing the electrical connection (fig,14).

In order to avoid water infiltrations, please apply silicone on the product perimeter, close to the wall.

Installation of the stainless steel external body: put the stainless steel body again, by matching the air exhausting grid with the air outlet of the motor block (fig. 13).

DDMEXT40 (dis. 15)

The appliance was designed to exhaust odors and vapors in the best way. The appliance is to be installed on the outside wall of the house and connected to the cooker-hood which is in the kitchen (fig. 16).

Installation:

the mounting of the appliance is to be made by qualified technicians. Using the appropriate drilling jig (fig. 17) drill all the holes marked on it into the external wall, by paying attention not to damage water pipes or power lines. The holes on the wall are to be drilled with a 8 mm. bit.

Insert, step by step, the following parts in the holes drilled:

- the corresponding plastic dowels supplied (fig. 17)
- the two telescopic pipes in the hole of 200 mm.
- the plastic pipe of 40 mm. diameter.

Before leaning the appliance against the wall, please remove the stainless steel carter using the 8 perimetrical screws (fig. 18), then insert the supply cord in the plastic pipe. Fix the appliance without the stainless steel external body, which was previously removed from the motor block, by matching the holes of the motor block with the holes on the wall. Tighten with the screws supplied.

Connection of the pipes:

the appliance is endowed with an air entrance to be connected with the telescopic pipes and an air outlet. After fixing the appliance on the external wall, connect the two telescopic pipes (fig. 12C), which are placed inside the wall, with the cooker-hood through the flexible pipes.

The fixing operations have to be carried out by using suitable metallic tools (pipes and tools have to be supplied by the installers).

Electrical connection to the hood:

Connect the the external motor's cable to the terminal board found inside the plastic box of the wiring . Make sure to respect the colors of cables when performing the electrical connection (fig,14).

In order to avoid water infiltrations, please apply silicone on the product perimeter, close to the wall.

Installation of the external carter:

mount the aesthetic carter making sure that the grill will match with the block motor air outlet (dis. 18).

DDMEXT27 (fig. 19)

The DDMEXT27 product has been designed to be installed under the kitchen cabinet, corresponding to the downdraft lower air outlet . This product can work only if it is used in combination with a Caple downdraft.

The appliance has been designed to suck vapours and odours in an optimal and almost noiseless way . We recommend to use the product only in RECIRCULATION MODE only and to use a constant diameter piping of 150mm or similar sections.

We recommend to use piping without elbows, as they negatively affect the performance of the appliance.

Installation procedure: place the appliance under the downdraft , corresponding to the air out-let, as shown in (fig. 20).

All fittings are supplied with the appliance, along with a rectangular pipe that connects the downdraft to the DDMEXT27 product

The appliance air outlet shall be connected to the cabinet, in such a way that the air sucked in from the kitchen can be recirculated back into the room. Piping to be connected to the DDMEXT27 product air outlet is not supplied with the appliance and should be purchased separately .

It is possible to direct the product air outlet according to your installation requirements, by rotating the air outlet flange as shown in (fig. 21).

The appliance is equipped with a 7 meter long power cable, to be connected to the hood in the specific terminal board found inside the plastic black box (Fig. 8).

With reference to the Energy Label standard and taking into account its performances, it is not necessary to equip the product with any time control device.

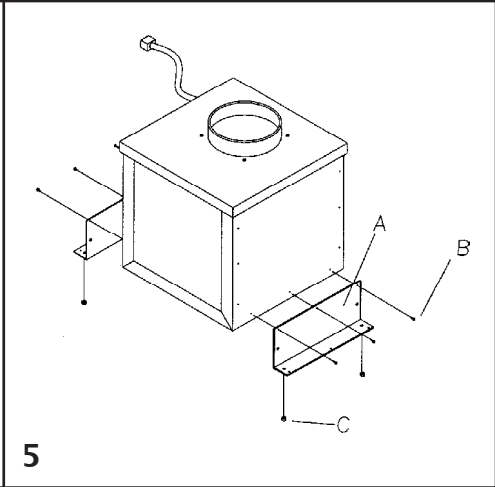
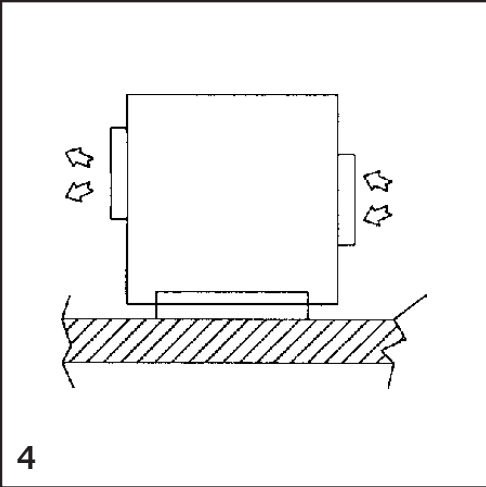
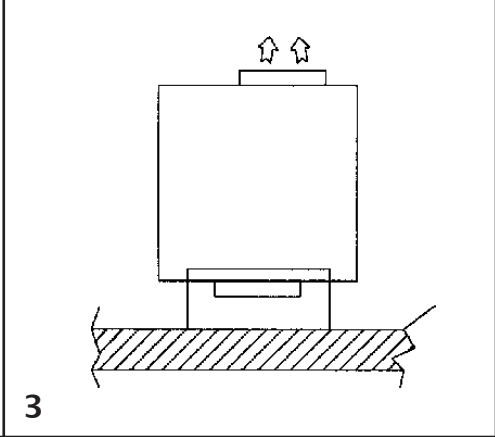
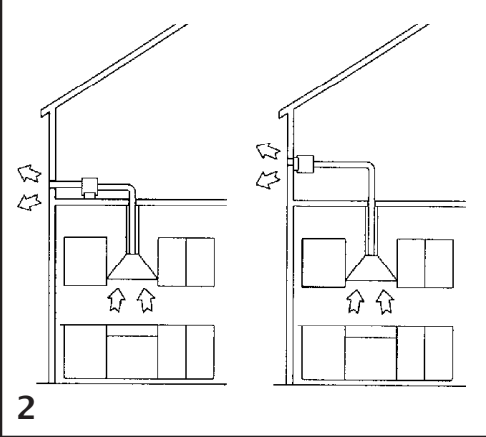
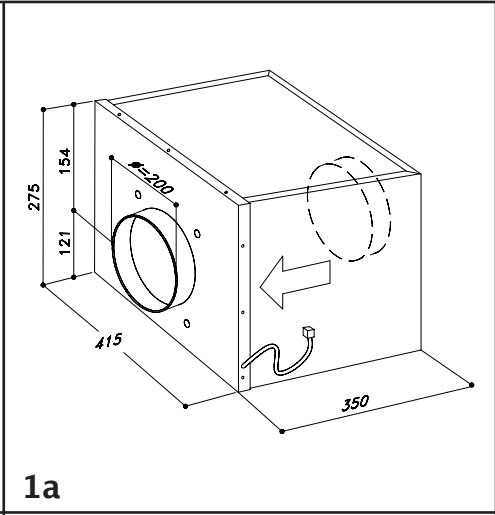
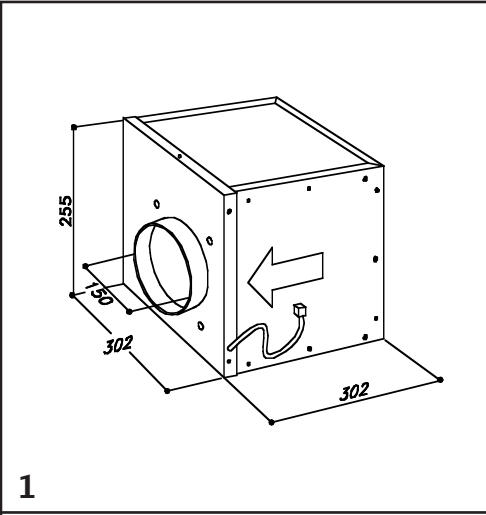

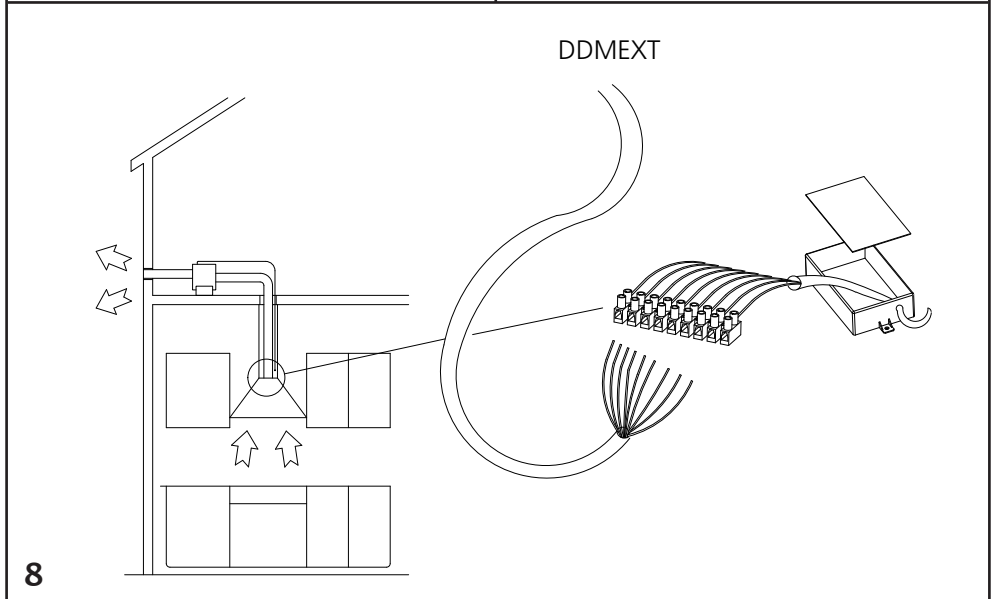
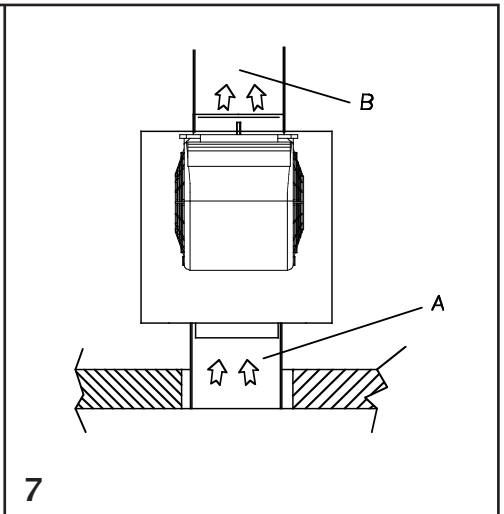
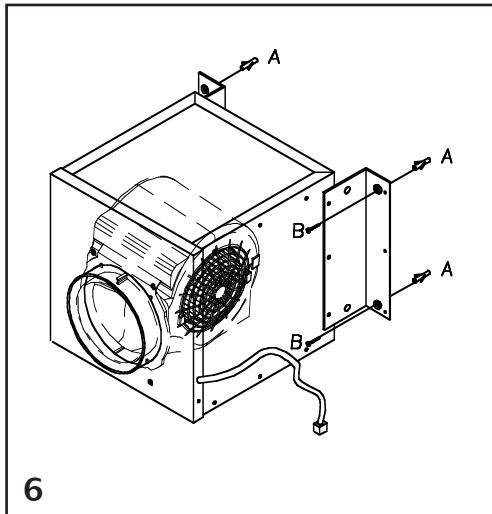

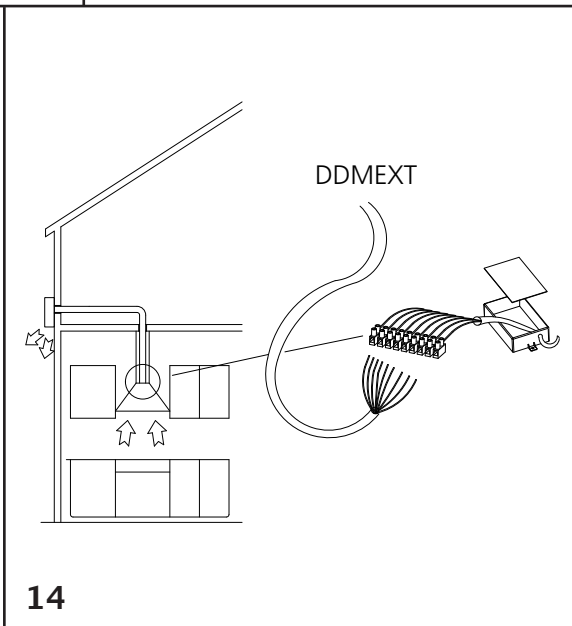
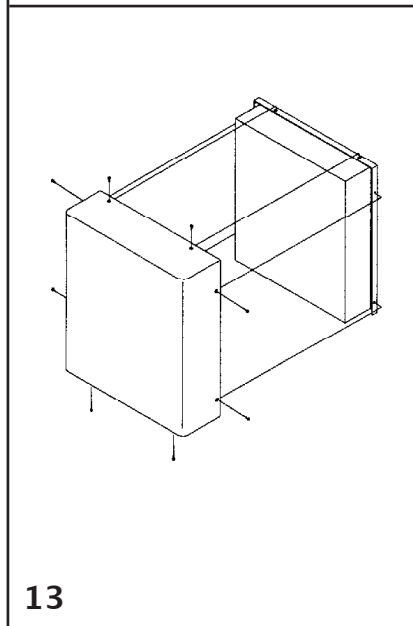
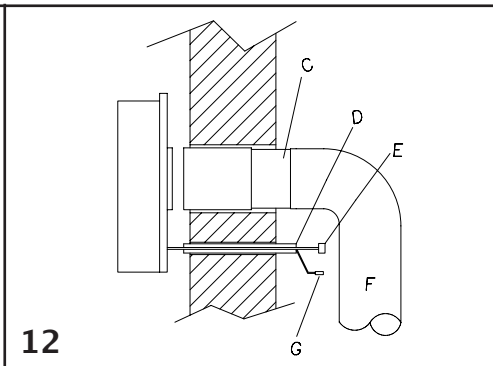
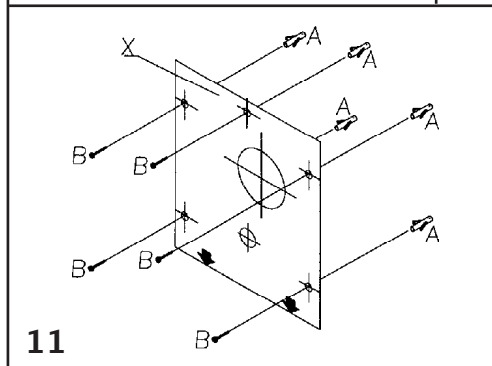
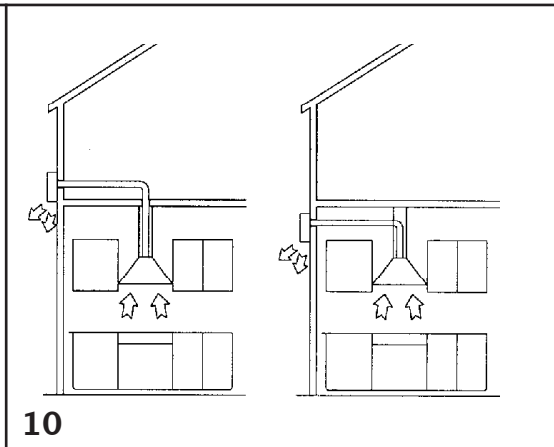
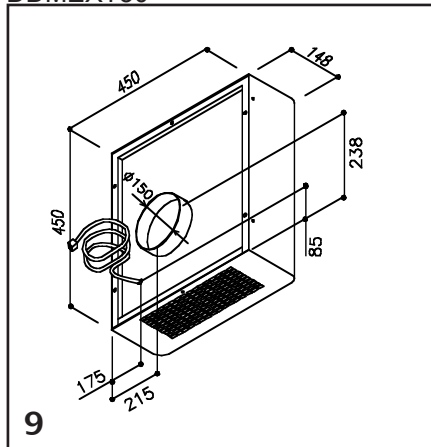

DDMEXT40

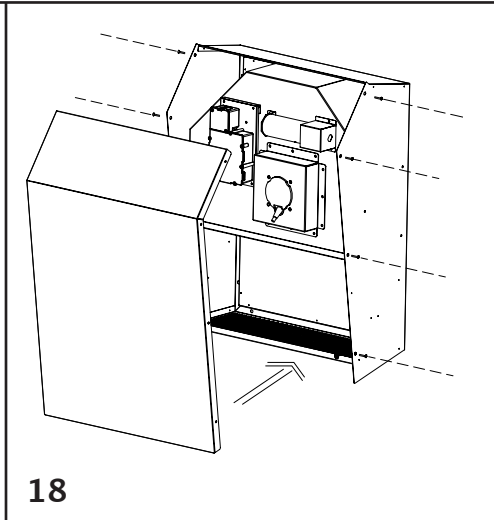
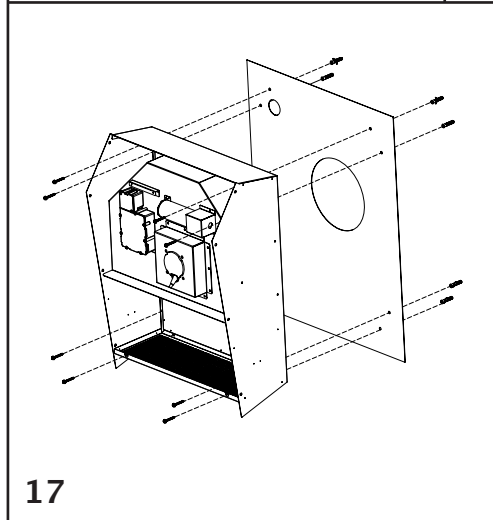
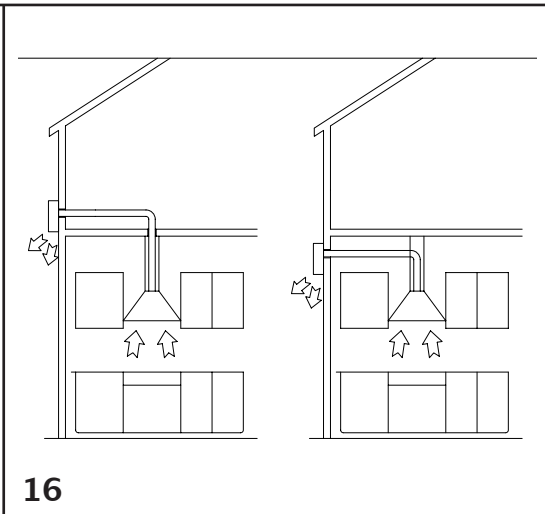
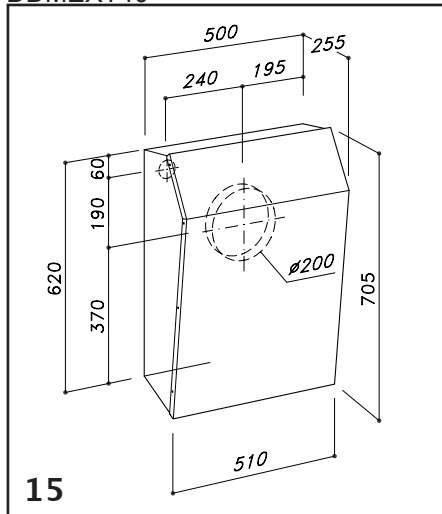

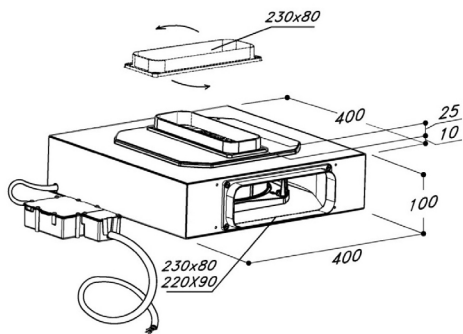

19

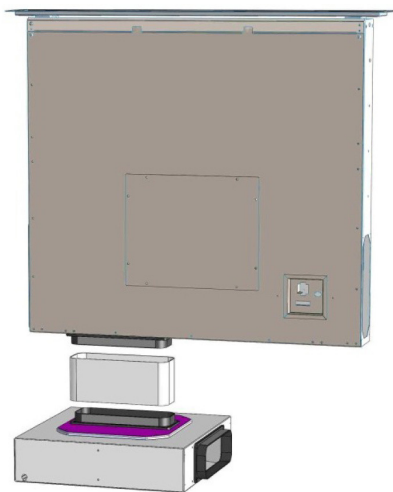

20

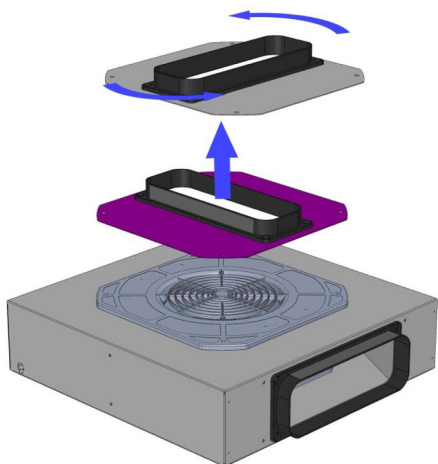

21

Caple
Fourth Way
Avonmouth
Bristol
BS11 8DW
www.caple.co.uk