



# MC900

Mirage 90cm cooker hood



**Technical information**

# MC900

Mirage 90cm cooker hood

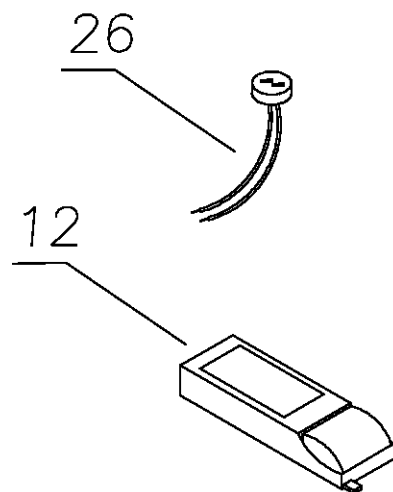
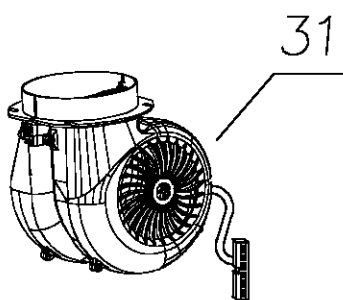
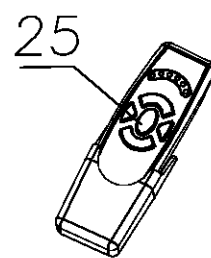
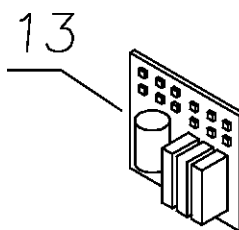
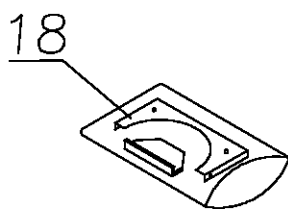
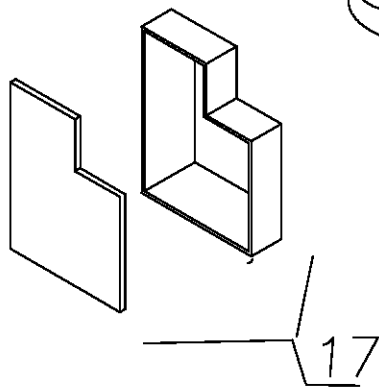
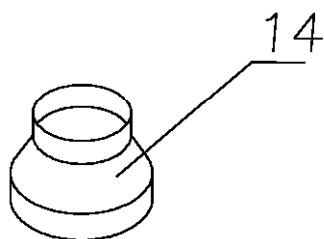
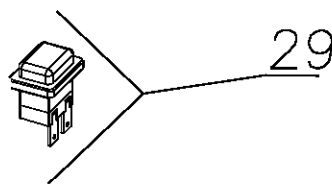
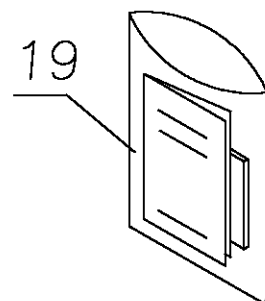
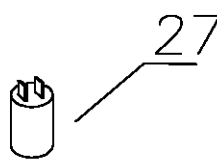
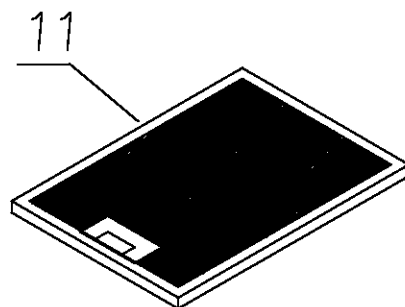
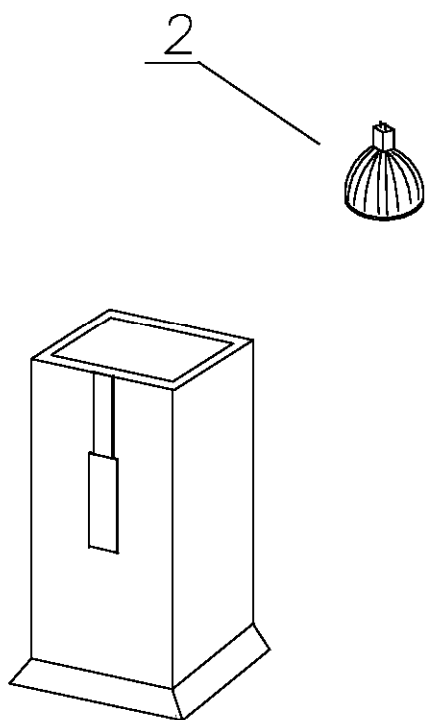
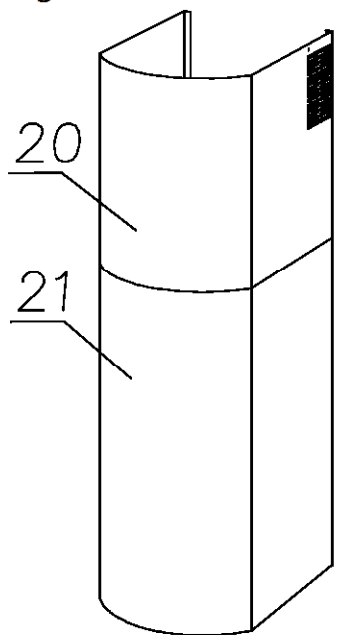



## MC900 - Mirage 90cm cooker hood

| Item | Part Code   | Description                          | Qty |
|------|-------------|--------------------------------------|-----|
| 2    | 42013199999 | DICHROIC LAMP 50 W 50 D. 840718.0101 | 1   |
| 11   | 60080199999 | GREASE FILTER 239X300                | 1   |
| 12   | 42030099999 | TRANSFORMER 20/105 W                 | 1   |
| 13   | 44001899999 | WIRING BOARD TYPE SLT/E              | 1   |
| 14   | 51071000399 | REDUCTION FLANGE 150/125 AE          | 1   |
| 17   | 75071439999 | WIRING BOX SET                       | 1   |
| 18   | 77008002004 | ACCESSORIES BAG FOR MODULES          | 1   |
| 19   | 90000104219 | instruction manual                   | 1   |
| 20   | 75038300001 | STAINLESS STEEL UPPER CHIMNEY M.202  | 1   |
| 21   | 75028300011 | STAINLESS STEEL UNDER CHIMNEY M.202  | 1   |
| 25   | 44002000999 | Remote controle                      | 1   |
| 26   | 60167999999 | SUPPORT FOR DICHROIC LAMPS           | 1   |
| 27   | 42040999999 | CAPACITOR 4 MICROF.                  | 1   |
| 29   | 75470199999 | EMERGENCY SWITCH/START NEON          | 1   |
| 31   | 75075000001 | MOTOR ASSEMBLY 800MC                 | 1   |