



ZI920WH

Caple Zodiac island hood



Technical information

ZI920WH

Caple Zodiac island hood

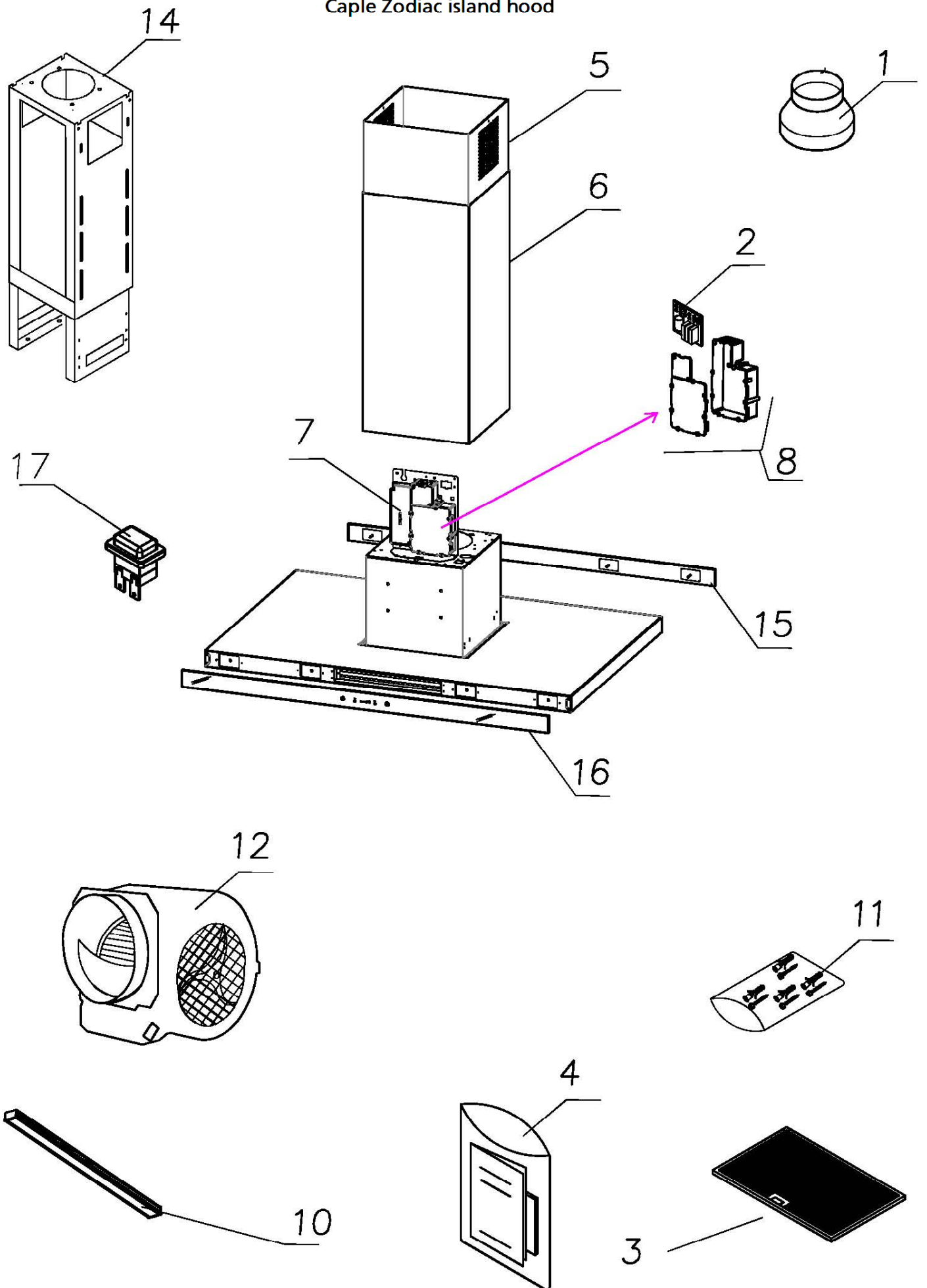



ZI920WH - Caple Zodiac island hood

Item	Part Code	Description	Qty
1	51071000399	REDUCTION FLANGE 150/125 AE	1
2	44023000023	SLTR 72 WIRING BOX	1
3	60080999999	GREASE FILTER 480 X 300 TYPE L	1
4	77193000002	A.S.D. SIL CAPLE	1
5	75033000001	STAINLESS STEEL UPPER CHIMNEY SI1	1
6	75023000102	ASS. R. TUBO INF. SI1 XS430 CAPLE	1
7	42030122320	TRANSFORMER EL. DC 12V EFU 122320	1
8	75071439999	WIRING BOX SET	1
10	42010320010	LED 320mm (Before Jun-14)	1
10	42010320006	LED 320mm (From Jun-14)	1
11	77006839000	ACCESSORIES BAG SIL 1/SIL 2	1
12	75061509999	MOTOR GPZ900	1
13	44010749999	CONTROL WIRING BOARD	1
14	75163000003	TELESCOPIC STRUCTURE SIL 1	1
15	75101392124	ASS. R. VETRO SLTC 92 ASS-B124 WH2	1
16	75101223137	ASS. R. VETRO POST. SIL24 ASS-B137 WH2	1
17	75470199999	EMERGENCY SWITCH/START NEON	1

ZI920WH

Caple Zodiac island hood

