



Ceiling Hood
Instruction Manual

**CE1122SS/
CE1122WH**



Contact Caple on 0117 938 7420 for spare parts or www.caple.co.uk

CONTENTS



Warnings	3
Environmental Protection	8
Opening the Panel	10
Installation	12
Remote Control	19
Timing	22
Cleaning and Maintenance	23
Caple Contact Details	26

WARNING

The appliance is not intended for use by young children or infirm persons without supervision. Young children should be supervised to ensure they do not play with the appliance.

The extracted air can't be conveyed through or into a duct used to let out fumes from appliances fed by energy other than electric power (eg. centralized heating, radiators, water heaters, etc.).

To evacuate the air outlet, please comply with the pertaining rules given by competent authorities.

- Provide the room with an adequate aeration when a cooker hood and appliances fed by energy other than electric power (gas, oil, or coal stoves, etc.) are used simultaneously.
- The cooker hood, when evacuating the extracted air, could generate a negative pressure in the room which can't exceed the limit of 0.04 mbar, in order to avoid the suck of exhausts deriving from the heat source. Therefore the room should be provided with air-intakes to allow a constant flow of fresh air.
- If the rating label in the cooker-hood does show the symbol  the appliance is built in class 11° and it does not need the earth connection. If the rating label in the cooker hood does not show the symbol , the appliance is built in class I° and it needs the earth connection.
- When performing the electrical connections on the appliance, please make sure that the current tap is provided with earth connection and that voltage values correspond to those indicated on the label placed inside the appliance itself.
- Before carrying out any cleaning or maintaining operations, the appliance needs to be removed from the electric grid.

- If the appliance is not provided with a non-separable flexible cable and plug, or with another device ensuring omnipolar disconnections from the grid, with an opening distance between the contacts of at least 3 mm, then such disconnecting devices must be supplied within the fixed installation.
- If the appliance is endowed with a supply cord and a plug, the appliance has to be put in a place where the plug can be reached easily.
- The use of materials which can burst into flames should be avoided in close proximity of the appliance
- When frying, please pay particular attention to fire risk due to oil grease. Being highly inflammable, fried oil is especially dangerous.
- Do not use uncovered electric grills. In order to avoid possible fire risk, all instructions for grease filter cleaning and for removing eventual grease deposits should be strictly followed.
- This appliance complies with all relevant local and national safety requirements. Inappropriate use can, however, lead to personal injury and damage to property.
- The cooker hood is not intended for outdoor use.
- It must only be used as a domestic appliance to extract vapours and remove odours from cooking. Any other usage is not supported by the manufacturer and could be dangerous.

- Where a recirculation cooker hood is fitted above a gas hob, please ensure that there is an adequate supply of fresh air into the room in which it is installed. Please seek the advice of a qualified gas fitter (e.g. GasSafe in the UK) if necessary.
- Children under 8 years of age must be kept away from the cooker hood unless they are constantly supervised.
- Children 8 years and older may only use the cooker hood unsupervised if they have been shown how to use it safely and recognise and understand the consequences of incorrect operation.
- The electrical safety of this appliance can only be guaranteed when correctly earthed. It is essential that this standard safety requirement is met. If in any doubt please have the electrical installation tested by a qualified electrician.
- Do not connect the appliance to the mains electricity supply by a multi-socket unit or an extension lead. These are a fire hazard and do not guarantee the required safety of the appliance.
- The cooker hood can get very hot during cooking due to heat rising from the hob.
- Do not touch the housing or the grease filters until the cooker hood has cooled down.

APPROPRIATE USE:

- This appliance is intended to be used in household and similar applications such as:
 - › Staff kitchen areas in shops, offices and other working environments.
 - › Farm Houses.
 - › By clients in hotels, motels and other residential type environments.
 - › Bed and breakfast type environments.



ENVIRONMENTAL PROTECTION

Waste electrical products should not be disposed of with household waste. Please recycle where facilities exist. Check with your Local Authority or retailer for recycling advice. This appliance is marked according to the European directive on Waste Electrical and Electronic Equipment (WEEE).

By ensuring this product is disposed of correctly, you will help prevent potential negative consequences for the environment and human health, which could otherwise be caused by inappropriate waste handling of this product. The symbol on the product indicates that this product may not be treated as household waste. Instead it shall be handed over to the applicable collection point for the recycling of electrical and electronic equipment. Disposal must be carried out in accordance with local environmental regulations for waste disposal.

For more detailed information about treatment, recovery and recycling of this product, please contact your local council, your household waste disposal service or the retailer where you purchased the product.

WARRANTY

Your new appliance is covered by warranty. The warranty card is enclosed - if it is missing, you must provide the following information to your retailer in order to receive a replacement: date of purchase, model and serial number. Registration can also be completed online by visiting www.caple.co.uk.

Ensure you keep your warranty card safe, you may need to show it to Caple Service together with proof of purchase. If you fail to show your warranty card you will incur all repair charges.

Spare parts are only available from Caple Service and spare parts authorised centres.

CE DECLARATIONS OF CONFORMITY



Radio Equipment Directive (RED) 2014/53/EU.

This Declaration is issued under the sole responsibility of the manufacturer.

Hereby, Caple declares that the radio equipment included in the product is in compliance with the RED directive 2014/53/EU.

The full text of the EU Declaration of Conformity is available on our website www.caple.co.uk.

UKCA DECLARATIONS OF CONFORMITY



This appliance has been manufactured to the strictest standards and complies with all applicable legislation.

TECHNICAL FICHE

This appliance conforms to all current and applicable energy regulations. To view the Technical Fiche that supports the energy labelling data, please visit the product page on our website www.caple.co.uk

OPENING THE PANEL

NOTE:

Two people are needed for the installation of this product.

OPENING THE PANEL

It is possible to open the grease filter cover panels by pulling them gently from the centre, as shown in Fig.1. They are held in place by magnets.

To work correctly, it is recommended to install the product at a maximum distance of 2000-2100mm, from the floor level.

Before proceeding with the installation of the appliance, check that all the components are not damaged, otherwise please contact your retailer and do not continue with the installation.

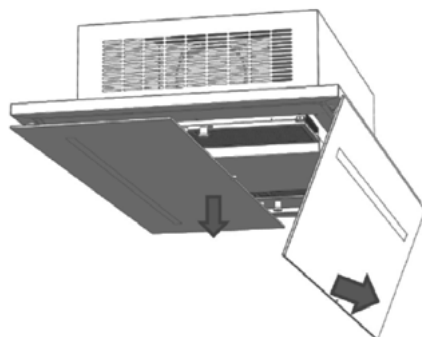

FIG.1

Use an air outlet pipe with a maximum length of no more than 5 metres. Keep the number of bends in the duct to a minimum as each bend reduces the suction efficiency equivalent to 1 linear meter. (E.g. If 2 90° bends are used, the length of the duct should not exceed 3 meters in length).

- › Avoid abrupt changes of direction.
- › Use a duct with a diameter of 150mm constant over the entire length.
- › Use a duct of recognised and approved material.

NOTE:

Ducting is not supplied with the product, this is to be supplied by the installer depending on the installation requirements.

For more information on venting, please see our 'Extraction & Ventilation guide' available at www.caple.co.uk

The cooker hood should be placed at a minimum distance of 65cm above the hob. It is the manufacturer of the hob who determines the clearance required and the clearance quoted by the hob manufacturer must be followed. In the absence of any instructions supplied with a gas hob the minimum distance between the hob and the hood must be at least 760mm.

The cooker hood should be placed at a minimum distance of 65cm above the hob. It is the manufacturer of the hob who determines the clearance required and the clearance quoted by the hob manufacturer must be followed. In the absence of any instructions supplied with a gas hob the minimum distance between the hob and the hood must be at least 760mm.

FREESTANDING INSTALLATION

RECIRCULATING VERSION

ATTENTION:

Let the power cord pass through the hood hole, as shown in Fig.2.

Open the glass/steel panels, following the instructions mentioned in the previous section and remove the grease filters and carbon filters (Fig.3).

When fixing the hood to the ceiling allow the electric cable to pass through into the hood (not supplied). Fix the hood to the ceiling using the four screws provided.

Make the electrical connection in to the metal box. The metal power supply box is positioned close to the electrical components, these are visible after removing the grease filters.

Ensure the motor is connected to the outer part of the body to allow the air to exit back into the room via the grille.

Once done, refit the grease filters, the carbon filters and close the glass/steel panels.



FIG.2

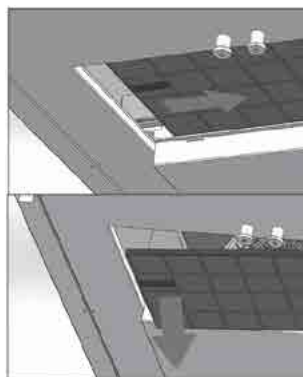

FIG.3

DUCTED VERSION

Turn the motor to extract the air to the upper side of the hood.

Open the glass/steel panels, and remove grease filters and carbon filters.

Remove the four screws shown in Fig.4. Remove the lower stainless steel as shown in Fig.5.

Then remove the screws holding the motor, as shown in Fig.6.

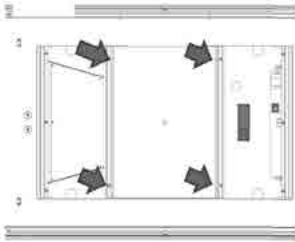

FIG.4

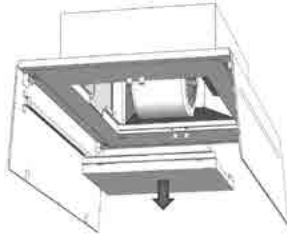

FIG.5

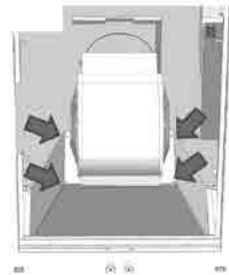

FIG.6

Open the hole in the middle of the upper side hood (Fig.7). Fix the blanking plug to the hole where the motor was before, using the four screws provided (Fig.8). Install the motor in the upper side using the four screws previously removed (Fig.9).

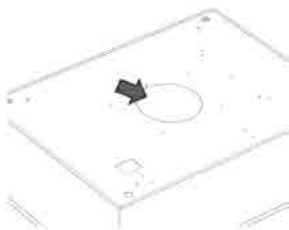

FIG.7

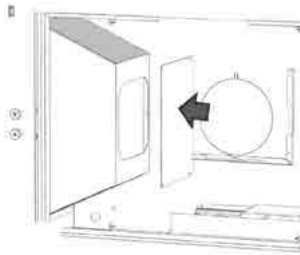

FIG.8

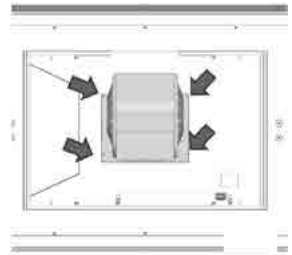
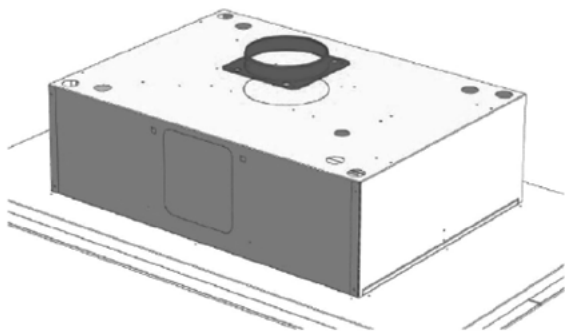

FIG.9

Install the air outlet with a joint diameter of 200mm to the middle of the hood. Fix it with the 8 screws supplied (Fig.10).



NOTE:

200mm or 150mm ducting can be used with this hood.

For the best performance, 200mm is recommended if the installation allows.

FIG.10

Continue with the installation as Recirculating version (Free standing).

NOTE:

The use of carbon filters is not necessary when the hood is being ducted to the outside.

Connect the internal motor or the external motor's cable to the terminal board found inside the plastic box for the wiring. The cables are colour coded, make sure the cables are respected when performing the electrical connection.

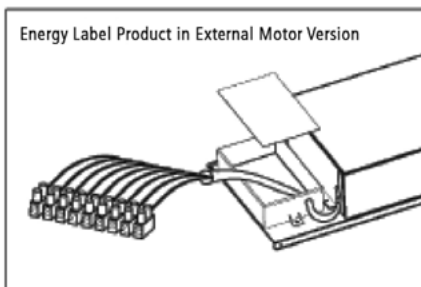
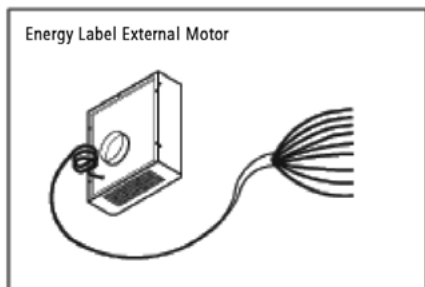

BUILT-IN INSTALLATION

For Built-In installation, remove the stainless steel cover (Fig.11).

Make a structure able to support the weight of the false ceiling (plasterboard), which must not burden the hood.

Mark the holes to fix the product into the false ceiling (Fig.12).

DUCTED VERSION

Make the holes using a 8mm drill bit and place the metric plugs provided in the holes.

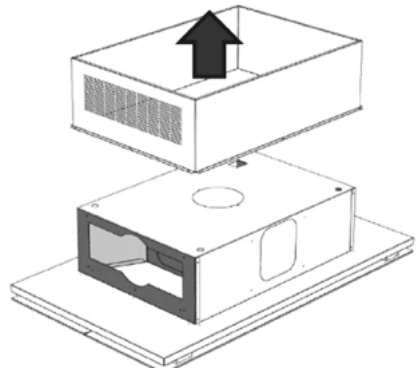

FIG.11

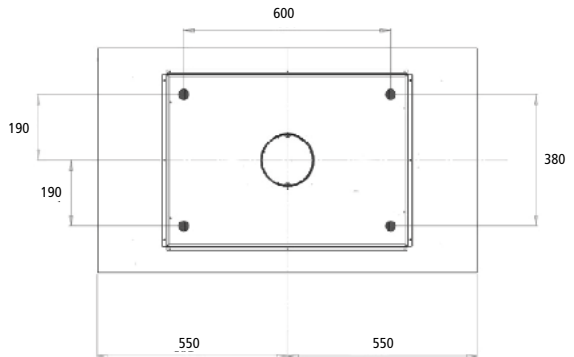

FIG.12

For Built-In installation, it is possible to select the air outlet location.

The product has been assembled with the air outlet of the motor placed on the short side, but it is possible to select the side of the cooker hood where the extracted air can be discharged, as follows:

- › Open the glass panels and remove the grease filters and carbon filters.
- › Unscrew the four screws shown in Fig.13.
- › Remove the lower stainless steel as shown in Fig.14.
- › Remove the four screws that fix the motor, shown in Fig.15.

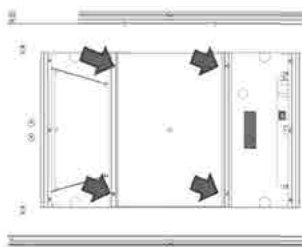

FIG.13

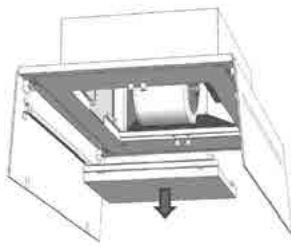

FIG.14

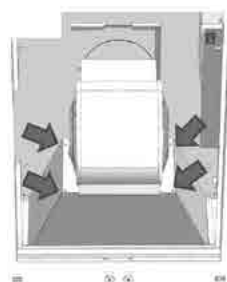

FIG.15

- › Open the hole in the middle of the upper side hood (Fig.16) or in the long side (Fig.17).

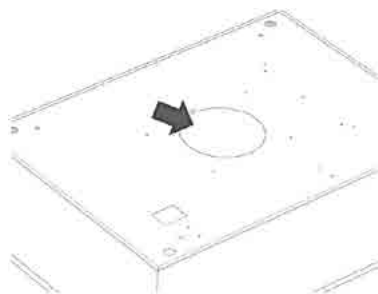

FIG.16

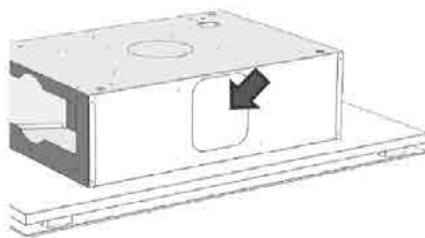

FIG.17

- › Fix the blanking plug to the hole where the motor was before, using the the four screws supplied. (Fig.18)
- › Install the motor facing the upper side or in the long side using the four screws earlier removed (Fig.19).
- › Fix the long screws into the metric plug, install the hood on the ceiling as shown in Fig.20. The false ceiling (plasterboard) must remain above the wider part of the hood.

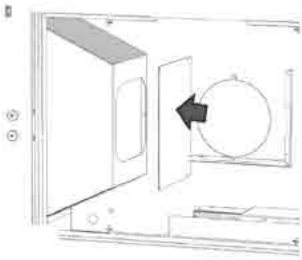

FIG.18

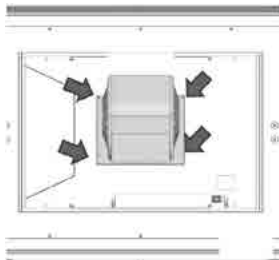

FIG.19

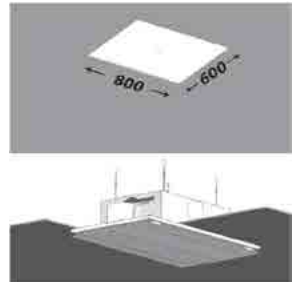

FIG.20

- › Install the air outlet with a joint diameter of 200mm to the middle of the hood. Fix it with the 8 screws supplied (Fig.21).

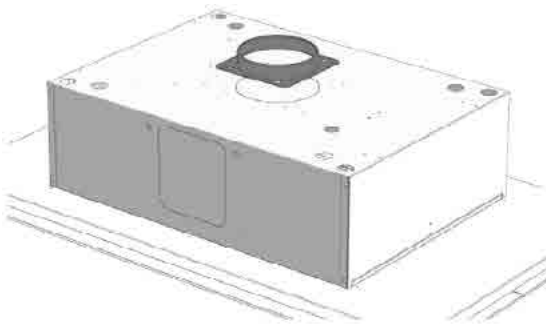

FIG.21

NOTE:

200mm or 150mm ducting can be used with this hood.

For the best performance, 200mm is recommended if the installation allows.

ATTENTION:

Let the power cord pass through the hood hole, as shown in Fig.22.

Make the electrical connection into the metal box. The metal power supply box is positioned close to the electrical components, this is visible after removing the grease filters.

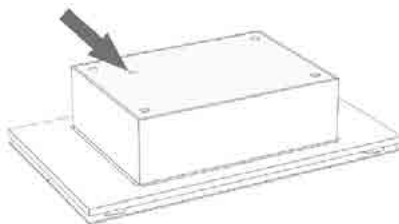
**FIG.22**

If you have selected the extract air from the short side of the hood, it is possible to facilitate the attachment of the tube by removing the cover shown in Fig.23.

NOTE:

The use of carbon filters is not necessary when the hood is being ducted to the outside.

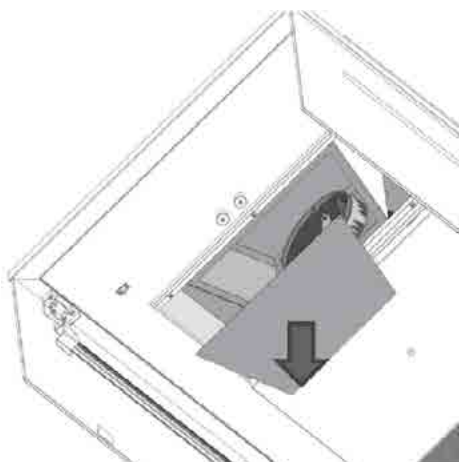
**FIG.23**

REMOTE CONTROL

When using for the first time, press and hold the light button for 5 seconds.

Remote control used for the remote operation of Caple hoods:

TECHNICAL DATA

Alkaline battery powered:	12V mod. 27A
Operating frequency:	433.92 Mhz
Combinations:	32.768
Max. consumption:	25 mA
Operating temperature:	-20 ÷ + 55 °C
Dimensions:	120 x 45 x 15 mm

OPERATION

The remote is equipped with 5 buttons for cooker hood management, as specified below:



Light ON/OFF command.



Motor ON (speed level 1) / OFF command.



Reduce speed.



Increase speed.



10-minute timer.

The set extraction speed is indicated by the LED in the extraction perimeter channel.

Each colour generated by the LED, corresponds to a specific speed, as shown below:

- › First speed WHITE
- › Second speed BLUE
- › Third speed DARK BLUE
- › Fourth speed RED

INITIAL OPERATING CONDITION

The manufacturer supplies the control unit ready to be used with preset codes.

STANDARD CONFIGURATION:

Standard configuration requires all cooker hood remote controls to be provided with the same transmission code. In the event two cooker hoods radio control system are installed in the same room or nearby, each system may affect the operation of the another. Therefore, the code of one radio control system must be changed.

GENERATING A NEW TRANSMISSION CODE:

The radio control system is provided with preset codes. Should new codes be required, proceed as follows: Press simultaneously buttons:



for two seconds. When LED's light on, press buttons:



(within 5 seconds). LED's flashing 3 times indicate the procedure is completed.

WARNING:

This operation permanently deletes the preset codes.

LEARNING THE NEW TRANSMISSION CODE

Once the transmission code is changed in the remote control unit, the electronic central unit of the cooker hood must be made to set the new code in the following way:

Press the main power-off button on the hood and then restore power to the electronic control unit. Within the next 15 seconds, press the Light Button to synchronise the central unit with the code.

RESET OF THE FACTORY CONFIGURATION:

To restore the Factory configuration, follow the procedure described below: simultaneously press buttons



for 2 seconds. When LED's light on, press buttons



(within 5 seconds). LED's flashing 6 times indicate the procedure is completed.

WARNING:

This operation permanently deletes the preset codes.

EMERGENCY BUTTON:

In the event that the remote control does not work, use the emergency button to switch the appliance off.

After any necessary repairs have been performed, reset the emergency button.

WARNING:

The battery should be replaced every year to guarantee the optimal range of the transmitter. To replace the battery, take the plastic lid off, remove the battery and replace it with a new one, observing the correct battery polarities. Used batteries should be discarded in special collection bins.

WARNING:

Any adjustments or modifications which have not been expressly approved by the holder of the legal conformity certificate may invalidate the user's rights relating to the operation of the device.

The products are endowed with an electronic device which automatically switches the product off after 4 hours working from the last operation.

TIMING

- › This product is equipped with intelligent electronics which include a timer device for speed controls when the air capacity exceeds 650m³/h. Internal motor models, with maximum air capacity higher than 650m³/h, are equipped with a timer device that automatically switches the speed from 4th to 3rd speed, after 5 minutes operation.
- › External motor models are equipped with remote motors that, as for internal motor versions, include a timer device that switches down the speed when it exceeds 650 m³/h. (See External Motors Instructions). Remote motors, whose air capacity exceeds 650m³/h at both 4th and 3rd speed, will have the following by default timer control functions: The speed is automatically switched from 4th to 2nd speed, after 6 minutes operation.
- › If the appliance is working at 3rd speed, it is automatically switched to 2nd speed, after 7 minutes operation. Operation speeds can also be changed during operation. The energy consumption of the appliance in standby mode is lower than 0.5W.

CLEANING AND MAINTENANCE

Careful maintenance ensures smooth operation and long-lasting performance. Special care must be taken with the grease filter. To access the filter, open the glass panels by gently pulling the side of the panel as shown in figure 1. Remove the grease filter by pulling its handle.

To replace the grease filter after cleaning, fulfil the same operation in reverse order. To remove the carbon filter, if installed, follow the same steps as the grease filter.

The carbon filter is located immediately above the grease filter. The charcoal filter has to be removed at first guiding it inside the location and then rotating it and removing it.

Charcoal filters (CAP64CF) should be replaced at least every 6 months, or sooner with heavier use. These can be purchased directly from www.caple.co.uk.

Warm water and neutral detergents are recommended to clean the appliance, while abrasive products should be avoided. Once cleaned, dry with a soft cloth.

DIMENSIONS

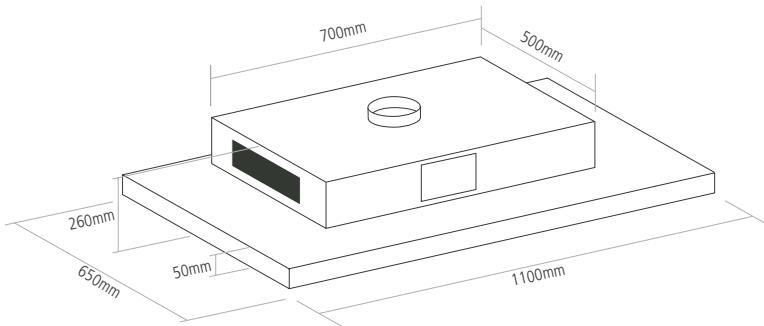



REPLACING LED LIGHTING

LIGHT SOURCE ENERGY CLASS

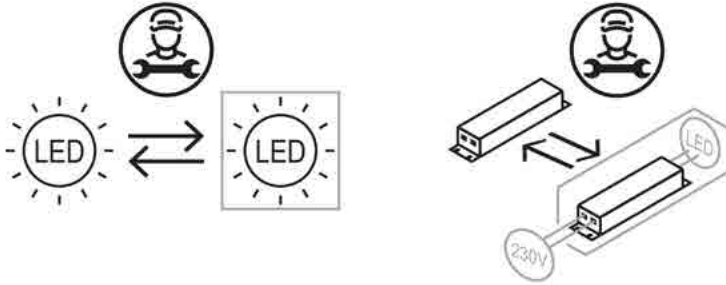
This product contains a light source of energy efficiency class F.



 The LED light must be replaced by an authorised engineer or similar only. For more information, please contact Caple service - 0117 938 7420 or service@caple.co.uk

 Unplug the unit from the power supply before starting the process.

1. Open the glass panels.
2. Use an appropriate tool to remove the screws that fix the LED bars.
3. Remove the LED light from its housing by sliding to the side. Disconnect the connector and change the LED light.
4. Implement the steps in reverse order.
5. After waiting 5 minutes, plug in the unit.

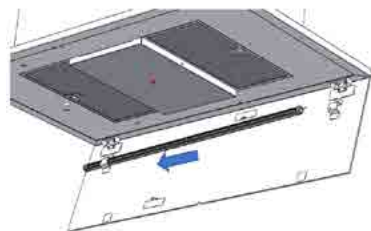
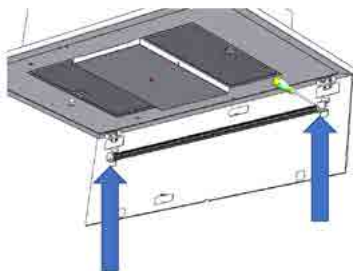
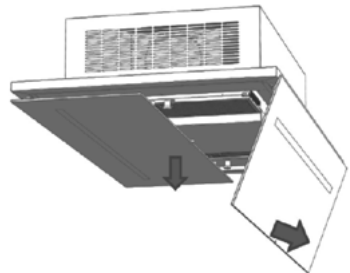



Caple Service
Fourth Way
Avonmouth
Bristol
BS11 8DW

T: 0117 938 1900
E: service@caple.co.uk
www.caple.co.uk