

Instruction manual for ceiling extractor

Model code: CE1121 & CE1121SS



Environmental protection



The symbol on the product or on its packaging indicates that this product may not be treated as household waste. Instead it shall be handed over to the applicable collection point for the recycling of electrical and electronic equipment. By ensuring this product is disposed of correctly, you will help prevent potential negative consequences for the environment and human health, which could otherwise be caused by inappropriate waste handling of this product. For more detailed information about recycling of this product, please contact your local city office, your household waste disposal service or the shop where you purchased the product. This appliance is marked according to the European directive 2002/96/EC on waste electrical and electronic equipment (WEEE).

CE Declarations of Conformity



This appliance has been manufactured to the strictest standards and complies with all applicable legislation, Low Voltage Directive (LVD) and Electromagnetic Compatibility Directive (EMC).

Contents

Warnings	5
Installation notes	5
Freestanding installation	6
Built-in installation	7
How to use you extractor	8
Maintenance	9

Warnings

This appliance is not intended to be used by young children or infirm persons without supervision. Young children should be supervised to ensure they do not play with the appliance. The air extracted cannot be conveyed through or into a duct used to let out fumes from appliances fed by energy other than electric power (eg. central heating, radiators, waterheaters, etc.). To evacuate the air outlet, please comply with the pertaining rules given by competent authorities.

Provide the room with adequate ventilation when a cooker hood and appliances fed by energy other than electric power (gas, oil, or coal stoves, etc.) are used simultaneously.

The cooker hood, when evacuating the extracted air, could generate a negative pressure in the room which must not exceed the limit of 0.04mbar, in order to avoid the suction of exhausts deriving from the heating source.

Therefore the room should be provided with air intakes to allow a constant flow of fresh air.

If the rating label in the cooker hood **shows** the symbol , the appliance is built in class II° and it **does not need** any earth connection.

If the rating label in the cooker hood **does not** show the symbol , the appliance is built in class I° and it **needs** the earth connection. When

performing the electrical connections on the appliance, please make sure that the current tap is provided with earth connection and that voltage values correspond to those indicated on the label placed inside the appliance itself.

Before carrying out any cleaning or maintaining operations, the appliance needs to be removed from the electric grid.

If the appliance is not provided with a non-separable flexible cable and plug, or with another device ensuring unipolar disconnections from the grid, with an opening distance between the contacts of at least 3 mm, then such disconnecting devices must be supplied within the fixed installation.

If the appliance is fitted with a supply cord and a plug, the appliance has to be put in a place where the plug can be reached easily.

The use of materials which can burst into flames should be avoided in close proximity of the appliance. When frying, please pay particular attention to fire risk due to oil grease. Being highly inflammable, fried oil is especially dangerous. Do not use uncovered electric grills. In order to avoid possible fire risk, all instructions for grease filter cleaning and grease deposits removal should be strictly followed.

opening the glass panels

It is possible to open the glass panels, which cover the grease filters, by slightly pulling the panel on a side, as shown on fig. 1

Installation notes

NOTE: Two people are needed for the installation of this product.

It is possible to open the glass panels, which cover the grease filters, by slightly pulling the panel on a side, as shown on fig. 1

In order to allow the hood to perform correctly, it is recommended to install the appliance at a distance of 2000 - 2100 mm from the floor. Before starting the appliance installation, please check that all components are not damaged, in such a case contact your retailer and do not carry out the installation. Furthermore, please read carefully all of the following installation instructions.

- For the best performance we recommend a exhausting pipe with a maximum length not exceeding 5 meters.
- Limit the number of elbows in the piping, since each elbow reduces the air capacity of 1 linear meter. (Eg. if you use 2 x 90 ° elbows, the length of piping should not exceed 3 meters).
- Avoid abrupt direction changes.
- Use a 150 mm constant diameter pipe for the whole length.
- Use ducting approved by the local standards in force.

Freestanding installation

Recirculating version

The product is ready for this version.

Attention:

Let the power cord pass through the hood hole, as shown in fig. 2.



Mark the holes to fix the product to the false ceiling.

Having marked the holes, make them by using a drill bit (diameter 8mm), and place in the holes the metric fixing plugs provided.

Open the glass panels, following the instructions mentioned in the previous section and remove the grease filters and carbon filters.

When fixing the hood to the ceiling allow the electrical cable to pass through into the hood (not supplied).

Fix the hood to the ceiling using the four screws provided.

Make the electrical connection in to the metal box (fig. 18). The power supply metal box is positioned close to the electrical components and you can see them after removing the grease filters.

Please connect the cable as shown in fig. 18.

Once done refit the carbon filters and grease filters, then close the glass panels

Ducted version

Turn the motor to evacuate the air from the upper side of the hood. Open the glass panels, following the instructions in the **Opening the glass panels** section and remove grease filters and carbon filters.

Remove the four screws shown in picture 4. Remove the lower stainless steel as shown in picture 5. Then remove the screws holding the motor, as shown in picture 6. Open the hole in the middle of the upper side hood (fig. 7). Fix the plug to the hole where there was the motor before, using the four screws provided. (fig. 9) Install the motor in the upper side by means of the four screws earlier removed (picture 10). Prearrange an air outlet exactly in the middle of the hood. Continue with the installation as Recirculating version (Free standing).

The use of carbon filters is not necessary in this case.

Built-in installation

In case of built-in version remove the stainless steel cover (fig. 11)



Ducted Version

Mark the holes to fix the product into the false ceiling (Fig.3).

Make the holes marked, by a drill bit diameter 8mm, and place the metric plugs provided in the holes. In the built-in version it is possible to select the air outlet side.

The product has been assembled with the air outlet of the motor placed on the short side but it is possible to select the side of the cooker hood where the air extracted can be discharged, as follows:

open the glass panels, following the instructions mentioned in the opening the glass panels section and remove the grease filters and carbon filters.

Unscrew the four screws shown in Fig. 4.

Remove the lower stainless steel as shown in picture 5.

Now remove the four screws that fix the motor, shown in picture 6.

Open the hole in the middle of the upper side hood (fig. 7) or in the long side (fig. 12). Fix the plug to the hole where there was the motor before, by means of the four screws supplied. (fig. 9)

Install the motor in the upper side or in the long side using the four screws earlier removed (fig. 10).

Fix the long screws into the metric plug, install the hood on the ceiling as shown in picture 13.

Make the electrical connection into the metal box.

The power supply metal box is positioned close to the electrical components and you can see them after removing the grease filters.

Please connect the cables as you can see in picture 18.

Ducting is not supplied with the product, this is to be supplied by the installer depending on the installation requirements.

If you have selected the output air from the short side of the hood, it is possible to facilitate the attachment of the tube by removing the cover shown in Fig. 16.

The use of carbon filters is not necessary in this case

The false ceiling (plasterboard) must remain above the wider part of the hood fig. 13. Make a structure able to support the weight of the false ceiling (plasterboard), which must not burden the hood.

Recirculating version

After the installation of the hood as described in the previous chapter, connect a pipe from the motor to the outer part of the niche. Make the electrical connection into the metal box.

Refit the grease filters, the carbon filters (fig.17) and close the glass panel.

RC001

RADIO CONTROL





Radio control used for the remote operation of ducted cooker hoods.

TECHNICAL DATA

- Alkaline battery powered: 12 V mod. 23 A
- Operating frequency: 433.92 Mhz
- Combinations: 32.768
- Max. consumption: 25 mA
- Operating temperature: -20 ÷ + 55 °C
- Dimensions: 120 x 45 x 15 mm.

OPERATING DESCRIPTION

The transmitter is equipped with 5 buttons for cooker hood management, as specified below:

-  : Light ON/OFF command.
-  : Motor ON (speed level 1) / OFF command.
-  : Reduce speed.
-  : Increase speed.
-  : 10-minute timer.

INITIAL OPERATING CONDITION

The manufacturer supplies the radio control unit ready to be used with codes preset in the Factory



OPERATION MODE

Standard configuration:

Standard configuration requires all "cooker hoods - radio control - system" to be provided with the same transmission code. In the event two cooker hoods - radio control system are installed in the same room or nearby, each system may affect the operation of the another. Therefore, the code of one radio control system must be changed.

Generatiing a new transmiissiion code:

The radio control system is provided with preset codes. Should new codes be required, proceed as follows: Press simultaneously buttons:



for two seconds. When Leds light on, press buttons:

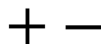

(within 5 seconds). Leds flashing 3 times indicate the procedure is completed.

WARNING! This operation deletes permanently the preset codes.

Learniiing the new transmiissiion code:

Once the transmission code is changed in the radio control unit, the electronic central unit of the cooker hood must be made to set the new code in the following way: Press the main power-off button of the hood and then restore power to the electronic control unit. Within the next 15 seconds, press the Light Button  to synchronise the central unit with the code.

Reset of the Factory configuration:

To restore the Factory configuration, follow the procedure described below: press simultaneously buttons:



for 2 seconds. When Leds light on, press buttons:

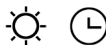

(within 5 seconds). Leds flashing 6 times indicate the procedure is completed.

WARNING! This operation deletes permanently the preset codes.

Emergency button:

In the event that the radio control does not work, use the emergency button to switch the appliance off. After any necessary repairs have been performed, reset the emergency button.

WARNING

The battery should be replaced every year to guarantee the optimal range of the transmitter.

To replace the exhausted battery, take the plastic lid off, remove the battery and replace it with a new one, observing the correct battery polarities.

Used batteries should be discarded in special collection bins.

The below product:

RC001 Radiio Controll
complies with the specifications set out in the R&TTE Directive 99/5/EC.



WARNING

Any adjustments or modifications which have not been expressly approved by the holder of the legal conformity certificate may invalidate the user's rights relating to the operation of the device.

Rev. 0 26/08/14

TIMING

As a result of the new EU65 "Energy label" and EU66 "Ecodesign" regulations issued by the European Commission, which came into force as from January 1st, 2015, our products have been adapted to comply with these new requirements.

All of the models complying with the energy label requirements, are equipped with new electronics including a timer device for suction speeds control, when the air capacity exceeds 650m³/h.

Internal motor models, with maximum air capacity higher than 650m³/h, are equipped with a timer device that automatically switches the suction speed from 4th to 3rd speed, after 5 minutes operation.

External motor models are equipped with remote motors that, as for internal motor versions, include a timer device that switches down the suction speed when it exceeds 650 m³/h. (See External Motors Instructions)

Remote motors, whose air capacity exceeds 650m³/h at both 4th and 3rd speed, will have the following by default timer control functions: The suction speed is automatically switched from 4th to 2nd speed, after 6 minutes operation.

If the appliance is working at 3rd speed, it is automatically switched to 2nd speed, after 7 minutes operation. Operation speeds can also be changed during operation.

The energy consumption of the appliance in stand – by mode is lower than 0.5W.

The products are endowed with an electronic device which allows the automatic switching off after 4 hours working from the last operation.

Maintenance

Correct maintenance helps to ensure optimal performance and a long life. Special care needs to be taken with the grease filter: It should be cleaned on a regular basis to prevent the build up of grease. To access the filter, proceed as described in the panel opening chapter.

Remove the grease filter, using the special handle.

To refit the grease filter after cleaning, carry out the same operation in reverse order. To remove the carbon filter, if fitted, follow the same steps as for the grease filter. The carbon filter is located immediately above the grease filter.

The charcoal filter has to be removed at first giding it inside the location and then rotating it and removing it.

Charcoal filters should be replaced at least every 6 months. More with heavy use. These can be purchased from your retailer or directly from Caple at www.caple.co.uk or call sales on 0117 938 1900

Tepid water and neutral detergents are recommended to clean the appliance, any abrasive products should not be used. Once cleaned dry with a soft cloth.

Dimensions

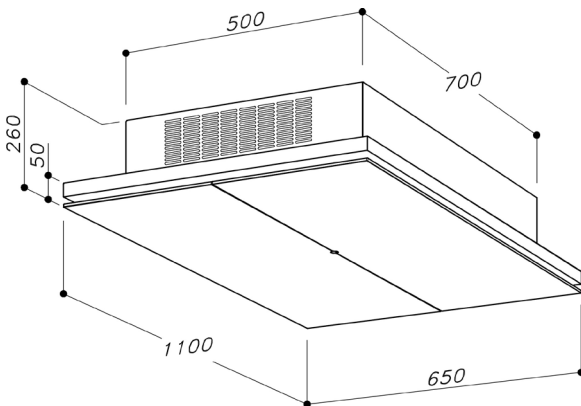

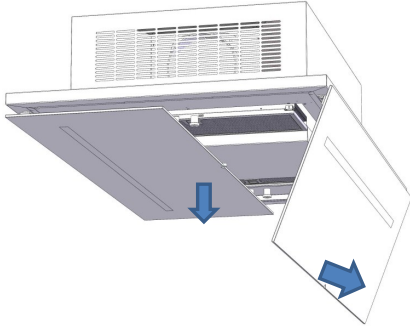

1

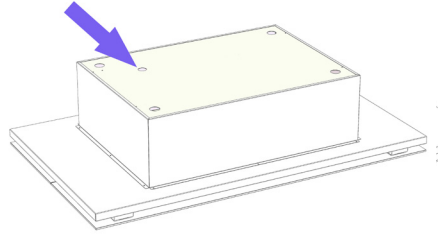

2

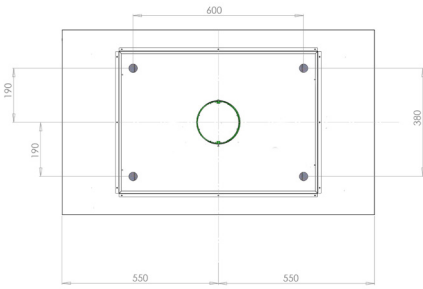

3

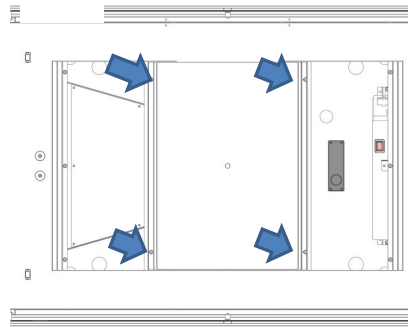

4

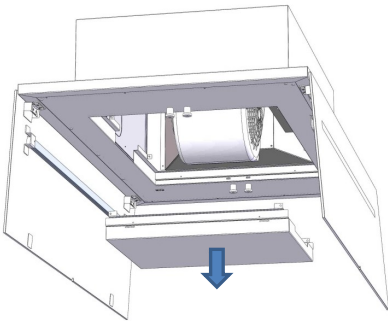

5

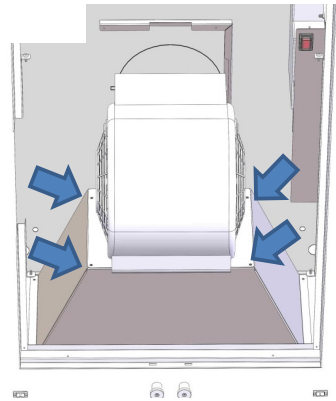

6

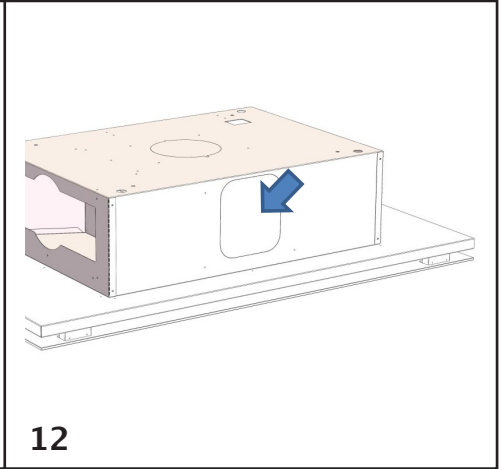
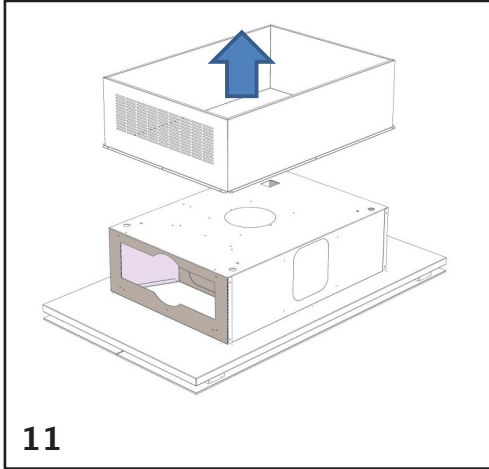
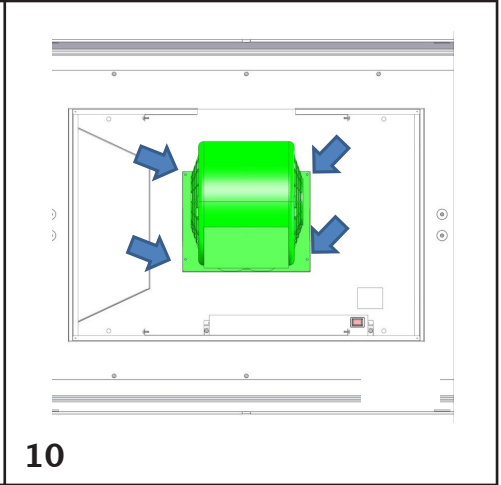
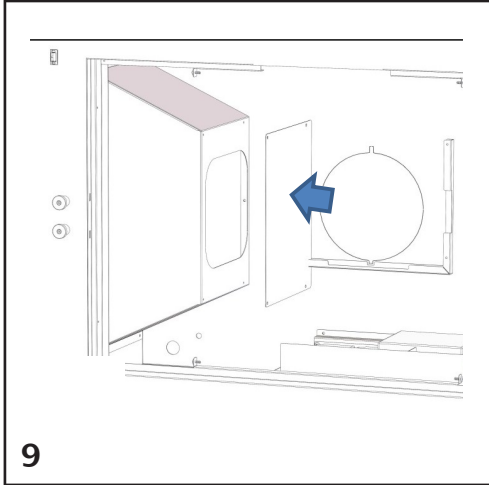
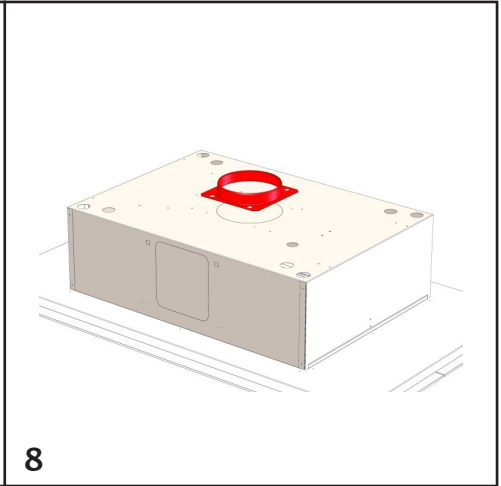
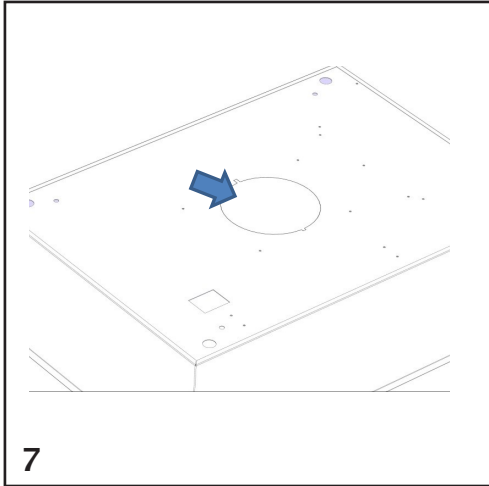

Caple
Fourth Way
Avonmouth
Bristol
BS11 8DW

www.caple.co.uk

0000000000 - MG 10 15