



# ceiling extractor instruction manual

## CE1101 | CE902



Contact Caple on 0117 938 7420 or for spare parts [www.caple.co.uk](http://www.caple.co.uk)





## CONTENTS

<b>WARNINGS</b>	<b>3</b>
<b>USES</b>	<b>8</b>
<b>INSTALLATION</b>	<b>9</b>
<b>REMOTE CONTROL</b>	<b>13</b>
<b>DIMMABLE LIGHTS FUNCTION</b>	<b>14</b>
<b>OPERATION MODE</b>	<b>14</b>
<b>TIMING</b>	<b>16</b>
<b>MAINTENANCE</b>	<b>17</b>

Please keep this instruction manual for future reference





## WARNINGS

The appliance is not intended for use by young children or infirm persons without supervision. Young children should be supervised to ensure they do not play with the appliance.

The extracted air can't be conveyed through or into a duct used to let out fumes from appliances fed by energy other than electric power (eg. centralized heating, radiators, water heaters, etc.).

To evacuate the air outlet, please comply with the pertaining rules given by competent authorities.

- Provide the room with an adequate aeration when a cooker hood and appliances fed by energy other than electric power (gas, oil, or coal stoves, etc.) are used simultaneously. The cooker hood, when evacuating the extracted air, could generate a negative pressure in the room which can't exceed the limit of 0.04 mbar, in order to avoid the suck of exhausts deriving from the heat source. Therefore the room should be provided with air-intakes to allow a constant flow of fresh air.
- If the rating label in the cooker-hood does show the symbol  the appliance is built in class 11° and it **does not need** the earth connection.

Please keep this instruction manual for future reference



- If the rating label in the cooker hood **does not** show the symbol , the appliance is built in class I° and it needs the earth connection.
- When performing the electrical connections on the appliance, please make sure that the current tap is provided with earth connection and that voltage values correspond to those indicated on the label placed inside the appliance itself.
- Before carrying out any cleaning or maintaining operations, the appliance needs to be removed from the electric grid.
- If the appliance is not provided with a non-separable flexible cable and plug, or with another device ensuring omnipolar disconnections from the grid, with an opening distance between the contacts of at least 3 mm, then such disconnecting devices must be supplied within the fixed installation. If the appliance is endowed with a supply cord and a plug, the appliance has to be put in a place where the plug can be reached easily.

The use of materials which can burst into flames should be avoided in close proximity of the appliance. When frying, please pay particular attention to fire risk due to oil grease. Being highly inflammable, fried oil is especially dangerous. Do not use uncovered electric grills. In order to avoid possible fire risk, all instructions for grease filter cleaning and for removing eventual grease deposits should be strictly followed.

Please keep this instruction manual for future reference





- This appliance complies with all relevant local and national safety requirements. Inappropriate use can, however, lead to personal injury and damage to property.
- The cooker hood is not intended for outdoor use.
- It must only be used as a domestic appliance to extract vapours and remove odours from cooking. Any other usage is not supported by the manufacturer and could be dangerous.
- Where a recirculation cooker hood is fitted above a gas hob, please ensure that there is an adequate supply of fresh air into the room in which it is installed. Please seek the advice of a qualified gas fitter (e.g. GasSafe in the UK) if necessary.
- Children under 8 years of age must be kept away from the cooker hood unless they are constantly supervised.
- Children 8 years and older may only use the cooker hood
- unsupervised if they have been shown how to use it safely and recognise and understand the consequences of incorrect operation.
- The electrical safety of this appliance can only be guaranteed when correctly earthed. It is essential that this standard safety requirement is met. If in any doubt please have the electrical installation tested by a qualified electrician.
- Do not connect the appliance to the mains electricity supply by a multi-socket unit or an extension lead. These

Please keep this instruction manual for future reference





are a fire hazard and do not guarantee the required safety of the appliance.

- The cooker hood can get very hot during cooking due to heat rising from the hob.
- Do not touch the housing or the grease filters until the cooker hood has cooled down.

Please keep this instruction manual for future reference





## ENVIRONMENTAL PROTECTION

Waste electrical products should not be disposed of with household waste. Please recycle where facilities exist. Check with your Local Authority or retailer for recycling advice. This appliance is marked according to the European directive 2012/19/EU on Waste Electrical and Electronic Equipment (WEEE).

By ensuring this product is disposed of correctly, you will help prevent potential negative consequences for the environment and human health, which could otherwise be caused by inappropriate waste handling of this product. The symbol on the product indicates that this product may not be treated as household waste. Instead it shall be handed over to the applicable collection point for the recycling of electrical and electronic equipment. Disposal must be carried out in accordance with local environmental regulations for waste disposal.

For more detailed information about treatment, recovery and recycling of this product, please contact your local council, your household waste disposal service or the retailer where you purchased the product

## CE DECLARATIONS OF CONFORMITY **CE**

Radio Equipment Directive (RED) 2014/53/EU

This Declaration is issued under the sole responsibility of the manufacturer.

Hereby, Caple declares that the radio equipment included in the product is in compliance with the RED directive 2014/53/EU.

The full text of the EU Declaration of Conformity is available on our website [www.caple.co.uk](http://www.caple.co.uk).

Please keep this instruction manual for future reference

Instruction manual CE1101 | CE902 7





## USES

CE1101 - CE902 with external motors manufactured by the same producer.

### PANELS OPENING

In CE1101, CE902 models it is possible to open the steel panels, which cover the grease filters, by slightly pulling on a side of the panel itself, as shown in Fig. 3. To achieve the complete opening of panels, you need to release the safety chains, by using the appropriate spring catches.

For proper working, it is recommended to install the appliance at a distance of 2000 - 2100 mm from the floor.

Before starting the appliance installation, please check that all components are not damaged, in such a case contact your retailer and do not carry out installation.

Furthermore, please read carefully all of the following installation instructions.

- Use an exhausting pipe whose maximum length does not exceed 5 meters.
- Limit the no. of elbows in the piping, since each elbow reduces the air capacity of 1 linear meter. (Ex.: if you use no. 2 x 90 ° elbows, the length of piping must not exceed 3 meters).
- Avoid abrupt direction changes.
- Use a 150 mm constant diameter pipe for the whole length.
- Use piping approved by standards in force.

Please keep this instruction manual for future reference



## INSTALLATION

Fit a false ceiling with an opening of the following sizes:

CE1101: 1065x665 mm with a minimum distance of 270 mm between the ceiling and the false ceiling.

CE902: 865x405 mm with a minimum distance of 270 mm between the ceiling and the false ceiling;

It is possible to select the side of the hood where the air suctioned can be discharged. After having chosen the most suitable position, prepare the ducting: an air outlet connection piece, with a diameter of 150 mm to be installed in the side selected, is provided with the appliance. Leave any unused exhaust outlets closed. Draw the outline of the hole to house the ceiling mounted hood on the solid ceiling (Fig. 1), according to the model chosen; make 4 holes in the ceiling according to the dimensions shown in (Fig. 2); place the metric plugs provided in the holes. Open the stainless steel panels, following the instructions mentioned in the USES section, and remove the grease filters in order to avoid damaging them in any way and too allow installation (Fig. 3); screw the threaded bars provided into the plugs (Fig. 4); the threaded bars are 250 mm long and serve to install the ceiling mounted hood at a distance from the solid ceiling of between 270 mm and 370 mm (Fig. 5); If the hood is installed with lateral air outlet, fit a false ceiling with an opening that has a minimum gap of 210 mm between the ceiling and the false ceiling (Fig. 12); in case of a larger gap between the hood and the ceiling, you need to use longer threaded bars.

Make the electrical connections and connect the air outlet pipe; place the ceiling-mounted hood into the niche, by inserting the threaded bars into the holes (Fig. 6); the outer edge of the hood needs to be perfectly flush with the false ceiling. Insert the plates and nuts provided into the threaded bars, making sure to tighten them securely (Fig. 7); refit the grease filters and filter cover panels. Connect the internal motor or the external motor's cable to the terminal board found inside the plastic box of the wiring. Make sure to respect the cables colours when performing the electrical connection (fig. 16).

**NOTE:** For more information on venting, please see our 'Extraction & Ventilation guide' available on our website [www.caple.co.uk](http://www.caple.co.uk).

Please keep this instruction manual for future reference

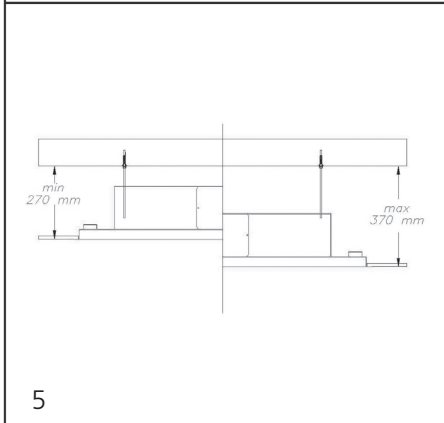
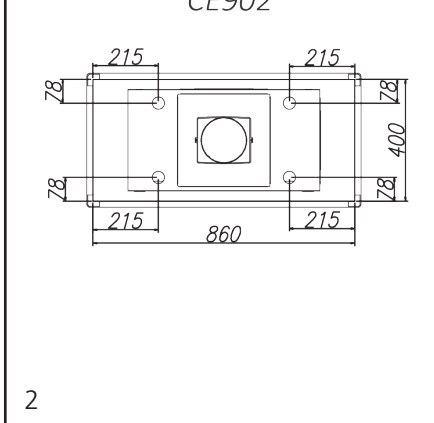
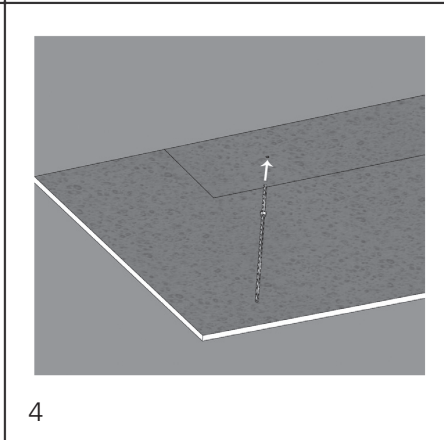
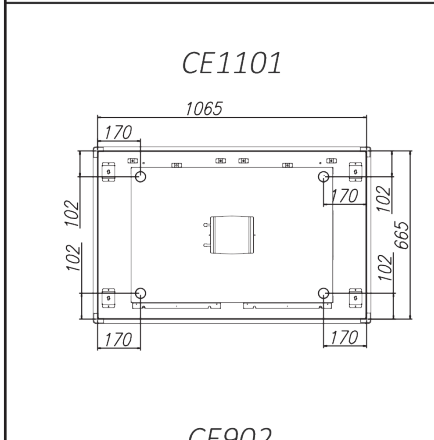
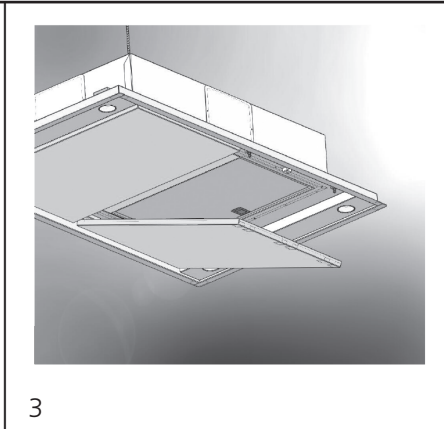
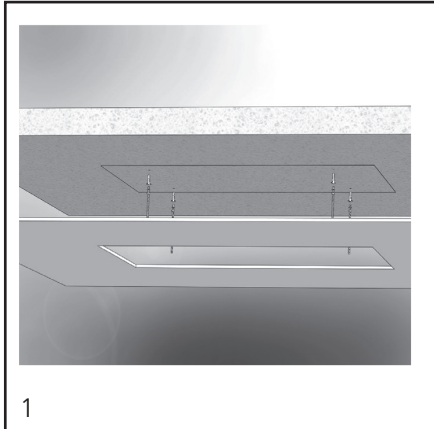

Please keep this instruction manual for future reference



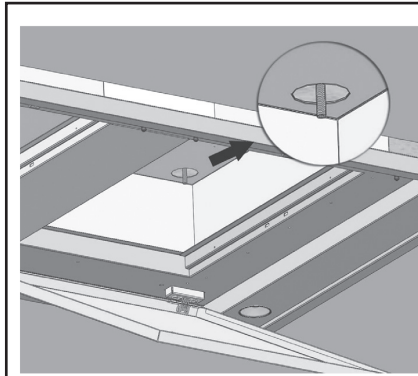

6

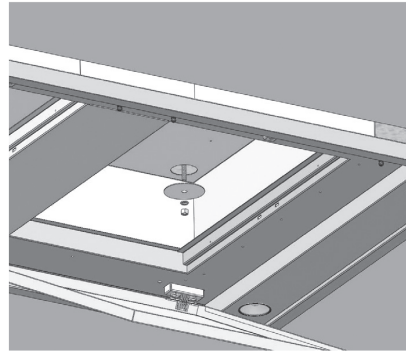

7

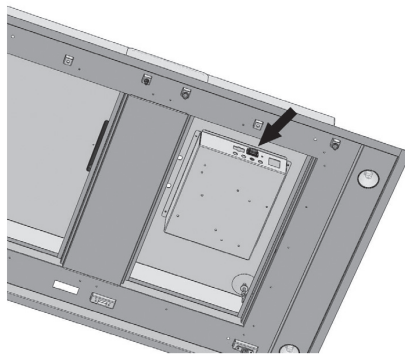

8

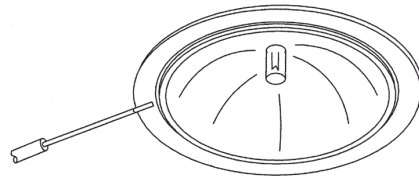

9



10

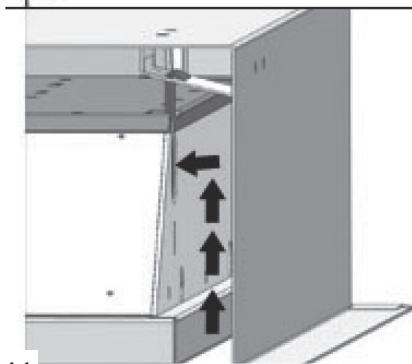

11

Please keep this instruction manual for future reference



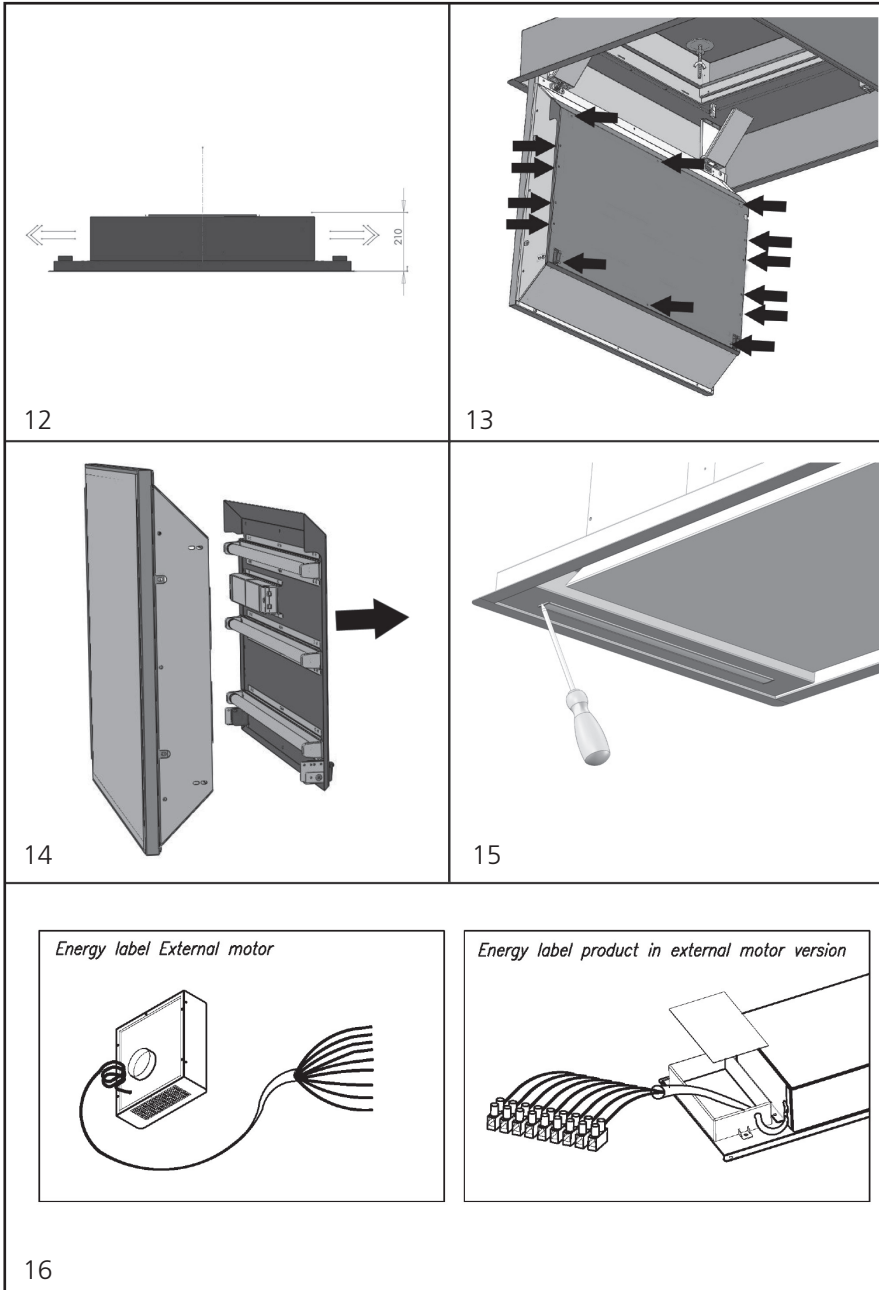

Please keep this instruction manual for future reference





## REMOTE CONTROL





Radio control used for the remote operation of Caple island hoods:

### Technical Data

Alkaline battery powered :	12 V mod. 23 A
Operating frequency :	433.92 Mhz
Combinations :	32.768
Max. consumption :	25 mA
Operating temperature:	-20 ÷ + 55 °C
Dimensions :	120 x 45 x 15 mm

## OPERATING DESCRIPTION

The transmitter is equipped with 5 buttons for cooker hood management, as specified below:

-  Light ON/OFF command.
-  Motor ON (speed level 1) / OFF command.
-  Reduce speed.
-  Increase speed.
-  10-minute timer.

### INITIAL OPERATING CONDITION

The manufacturer supplies the radio control unit ready to be used with codes preset in the Factory



Please keep this instruction manual for future reference



## OPERATION MODE

### Standard configuration:

Standard configuration requires all cooker hoods radio control - system to be provided with the same transmission code. In the event two cooker hoods radio control system are installed in the same room or nearby, each system may affect the operation of the another. Therefore, the code of one radio control system must be changed.

### Generating a new transmission code:

The radio control system is provided with preset codes. Should new codes be required, proceed as follows: Press simultaneously buttons:



for two seconds. When LEDs light on, press buttons:



(within 5 seconds). Leds flashing 3 times indicate the procedure is completed.

### WARNING:

This operation deletes permanently the preset codes.

### Learning the new transmission code:

Once the transmission code is changed in the radio control unit, the electronic central unit of the cooker hood must be made to set the new code in the following way: Press the main power-off button of the hood (fig. 11) and then restore power to the electronic control unit. Within the next 15 seconds, press the Light Button  to synchronise the central unit with the code.

### DIMMABLE LIGHTS FUNCTION

This function provides for lights dimmability, ranging from 20% to 100%, by continuously pressing the light key on the remote control.

Functions are the following:

- Hood light off - press the light key - light on at 100%.
- Light on at 100% - press the lightkey - light off.
- Light on at 100% - continuously press the light key - brightness reduction.

Please keep this instruction manual for future reference





- Releasing the key during reduction or increase - light keeps the luminous intensity reached.
- Light on - dimmed - continuously press the light key - brightness is inverted if compared to the previous function.

### **Reset of the Factory configuration:**

To restore the Factory configuration, follow the procedure described below: press simultaneously buttons:



for 2 seconds. When LEDs light on, press buttons:

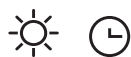

(within 5 seconds). LEDs flashing 6 times indicate the procedure is completed.

**WARNING! This operation deletes permanently the preset codes.**

### **Emergency button:**

In the event that the radio control does not work, use the emergency button to switch the appliance off. After any necessary repairs have been performed, reset the emergency button.

### **WARNING:**

The battery should be replaced every year to guarantee the optimal range of the transmitter. To replace the exhausted battery, take the plastic lid off, remove the battery and replace it with a new one, observing the correct battery polarities. Used batteries should be discarded in special collection bins.

### **WARNING:**

Any adjustments or modifications which have not been expressly approved by the holder of the legal conformity certificate may invalidate the user's rights relating to the operation of the device.

The products are endowed with an electronic device which allows the automatic switching off after 4 hours working from the last operation.

Please keep this instruction manual for future reference



## TIMING

- As a result of the new EU65 "Energy label" and EU66 " Ecodesign" regulations issued by the European Commission, which came into force as from January 1st, 2015 , our products have been adapted to comply with these new requirements. All of the models complying with the energy label requirements, are equipped with new electronics including a timer device for speed controls, when the air capacity exceeds 650m<sup>3</sup>/h. Internal motor models, with maximum air capacity higher than 650m<sup>3</sup>/h, are equipped with a timer device that automatically switches the speed from 4th to 3rd speed, after 5 minutes operation.
- External motor models are equipped with remote motors that , as for internal motor versions, include a timer device that switches down the speed when it exceeds 650 m<sup>3</sup>/h. (See External Motors Instructions). Remote motors, whose air capacity exceeds 650m<sup>3</sup>/h at both 4th and 3rd speed, will have the following by default timer control functions: The speed is automatically switched from 4th to 2nd speed, after 6 minutes operation.
- If the appliance is working at 3rd speed, it is automatically switched to 2nd speed, after 7 minutes operation. Operation speeds can also be changed during operation. The energy consumption of the appliance in standby mode is lower than 0.5W.

Please keep this instruction manual for future reference



## MAINTENANCE

- An accurate maintenance guarantees good functioning and long-lasting performance.
- Special care must be paid with grease filters: to remove the grease filter please follow the instructions given in the 'USES' section , according to the model chosen.
- Remove the grease filter by pulling its handle.
- To reinsert the grease filter after the cleaning, just perform the opposite operation.  
**Attention:**after refastening the stainless steel panel make sure that it is properly fixed.
- **To clean the appliance itself** tepid water and neutral detergents are recommended, while abrasive products must be avoided. For steel appliances specialized detergents are recommended (please follow the instructions mentioned on the product itself to obtain the desired results).
- **To replace the lamp, (CE1101)**  
remove the lamp (Fig. 9) and replace it with a lamp of the same kind.
- **To replace led strip (CE902)**  
Using an appropriate tool, remove the LED bar from its seat (refer to fig. 15), disconnect it electronically using the appropriate connector then substitute it with a LED bar with same characteristics.

Please keep this instruction manual for future reference



Notes:

Please keep this instruction manual for future reference





Please keep this instruction manual for future reference





Caple Service  
Fourth Way  
Avonmouth  
Bristol  
BS11 8DW

t: 0117 938 7420  
e: [service@caple.co.uk](mailto:service@caple.co.uk)  
[www.caple.co.uk](http://www.caple.co.uk)

Contact Caple on 0117 938 7420 or for spare parts [www.caple.co.uk](http://www.caple.co.uk)

