



Storm Built-Under Hood  
Instruction Manual

---

# ST523 / ST853



Contact Caple on 0117 938 7420 for spare parts or [www.caple.co.uk](http://www.caple.co.uk)

## CONTENTS

---

Safety Instructions	3
Environmental Protection	7
Uses	9
Installation	10
Control Panel	13
Timing	14
Cleaning and Maintenance	15
Caple Contact Details	20

## WARNING:

- The appliance is not intended for use by young children or infirm persons without supervision. Young children should be supervised to ensure they do not play with the appliance.
- The cooking surface and the inferior part of the cooker hood must be at a minimum distance of 65 cm.
- The extracted air can't be conveyed through or into a duct used to let out fumes from appliances fed by energy other than electric power (eg. centralized heating, radiators, water-heaters, etc.).
- To evacuate the air outlet, please comply with the pertaining rules given by competent authorities.
- Provide the room with an adequate aeration when a cooker hood and appliances fed by energy other than electric power (gas, oil, or coal stoves, etc.) are used simultaneously. The cooker hood, when evacuating the extracted air, could generate a negative pressure in the room which can't exceed the limit of 0.04 mbar, in order to avoid the suck of exhausts deriving from the heat source. Therefore the room should be provided with air-intakes to allow a constant flow of fresh air.

- When performing the electrical connections on the appliance, please make sure that the current tap is provided with earth connection and that voltage values correspond to those indicated on the rating label placed inside the appliance itself.
- Before carrying out any cleaning or maintaining operations, the appliance needs to be removed from the electric grid. If the appliance is not provided with a non-separable flexible cable and plug, or with another device ensuring omnipolar disconnections from the grid, with an opening distance between the contacts of at least 3 mm, then such disconnecting devices must be supplied within the fixed installation.
- If the fixed appliance is endowed with a supply cord and a plug, the appliance has to be put in a place where the plug can be reached easily.
- The use of materials which can burst into flames should be avoided in close proximity of the appliance. When frying, please pay particular attention to fire risk due to oil grease. Being highly inflammable, fried oil is especially dangerous. Do not use uncovered electric grills. In order to avoid possible fire risk, all instructions for grease-filter cleaning and for removing eventual grease deposits should be strictly followed.
- This appliance complies with all relevant local and national safety requirements. Inappropriate use can, however, lead to personal injury and damage to property.
- The cooker hood is not intended for outdoor use.
- It must only be used as a domestic appliance to extract vapours and remove odours from cooking. Any other usage is not supported by the manufacturer and could be dangerous.
- Where a recirculation cooker hood is fitted above a gas hob, please ensure that there is an adequate supply of fresh air into the room in which it is installed. Please seek the advice of a qualified gas fitter (e.g. GasSafe in the UK) if necessary.
- Children under 8 years of age must be kept away from the cooker hood unless they are constantly supervised.
- Children 8 years and older may only use the cooker hood unsupervised if they have been shown how to use it safely and recognise and understand the consequences of incorrect operation.
- The electrical safety of this appliance can only be guaranteed when correctly earthed. It is essential that this standard safety requirement is met. If in any doubt please have the electrical installation tested by a qualified electrician.
- Do not connect the appliance to the mains electricity supply by a multi-socket unit or an extension lead. These are a fire hazard and do not guarantee the required safety of the appliance.
- The cooker hood can get very hot during cooking due to heat rising from the hob.

- Do not touch the housing or the grease filters until the cooker hood has cooled down.

## APPROPRIATE USE:

- This appliance is intended to be used in household and similar applications such as:
  - › Staff kitchen areas in shops, offices and other working environments.
  - › Farm Houses.
  - › By clients in hotels, motels and other residential type environments.
  - › Bed and breakfast type environments.



## ENVIRONMENTAL PROTECTION

Waste electrical products should not be disposed of with household waste. Please recycle where facilities exist. Check with your Local Authority or retailer for recycling advice. This appliance is marked according to the European directive on Waste Electrical and Electronic Equipment (WEEE).

By ensuring this product is disposed of correctly, you will help prevent potential negative consequences for the environment and human health, which could otherwise be caused by inappropriate waste handling of this product. The symbol on the product indicates that this product may not be treated as household waste. Instead it shall be handed over to the applicable collection point for the recycling of electrical and electronic equipment. Disposal must be carried out in accordance with local environmental regulations for waste disposal.

For more detailed information about treatment, recovery and recycling of this product, please contact your local council, your household waste disposal service or the retailer where you purchased the product.

## WARRANTY

Your new appliance is covered by warranty. The warranty card is enclosed - if it is missing, you must provide the following information to your retailer in order to receive a replacement: date of purchase, model and serial number. Registration can also be completed online by visiting [www.caple.co.uk](http://www.caple.co.uk).

Ensure you keep your warranty card safe, you may need to show it to Caple Service together with proof of purchase. If you fail to show your warranty card you will incur all repair charges.

Spare parts are only available from Caple Service and spare parts authorised centres.

## CE DECLARATIONS OF CONFORMITY



This appliance has been manufactured to the strictest standards and complies with all applicable legislation, Low Voltage Directive (LVD) and Electromagnetic Compatibility (EMC).

## UKCA DECLARATIONS OF CONFORMITY



This appliance has been manufactured to the strictest standards and complies with all applicable legislation.

## TECHNICAL FICHE

This appliance conforms to all current and applicable energy regulations. To view the Technical Fiche that supports the energy labelling data, please visit the product page on our website [www.caple.co.uk](http://www.caple.co.uk).

## USES

The appliance is already arranged both for re-circulation and ducted installation.

- › In Recirculation mode (Fig.1), the air and fumes conveyed by the appliance are cleaned both by a grease filter and by an active charcoal filter, and put again into circulation through the hole made in the top of the cabinet.
- › In ducted mode (Fig.2), fumes are directly conveyed outside, through an evacuation duct connected from the extractor to the outside. Both charcoal filter and air deflector are not necessary in this case.

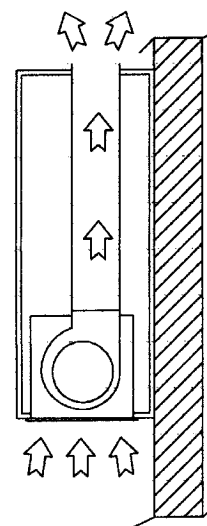

Fig.1.

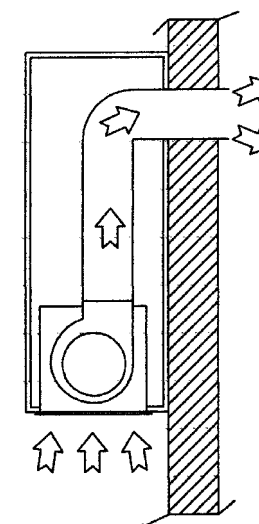

Fig.2.

## INSTALLATION

Before installing the appliance, make sure that none of the parts are damaged in any way. In case of damaged parts, contact your retailer and do not proceed with installation.

Read all of the following instructions with care before installing the appliance:

- › If venting the hood, use an air outlet pipe of the shortest possible length.
- › Limit the number of pipe bends.
- › Use a duct of recognised and approved material.
- › Avoid any abrupt changes of direction and use a duct with a diameter of 150mm constant over the entire length.

### NOTE:

For more information on venting, please see our 'Extraction & Ventilation guide' available at [www.caple.co.uk](http://www.caple.co.uk)

### ATTENTION: AT LEAST TWO PEOPLE ARE NEEDED TO PERFORM THE INSTALLATION.

Before installing the appliance, in order not to damage the appliance itself, the metal grease filter should be removed. This can be removed by pushing the special filter handle toward the back side of the cooker hood and pulling it downwards so to unfasten it from its slot (Fig.3).

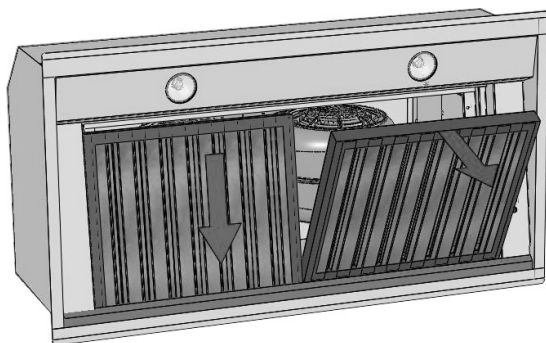

FIG.3

- › Make a cut-out in the bottom of the cabinet which is suitable to hold the appliance in position (Fig.4).
- › Prepare the power supply.
- › Create a hole for air evacuation.
- › Adjust the position of the stop side-springs using the appropriate screws, according to the thickness of the board the appliance will be fixed to (Fig.5).
- › Insert the appliance into the hole made in the cabinet until the stop click of the side springs is heard and the appliance is locked in position.
- › Insert the screws provided into the holes inside the appliance to secure it completely (Fig.6).

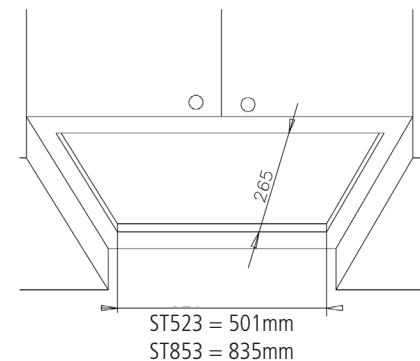

FIG.4

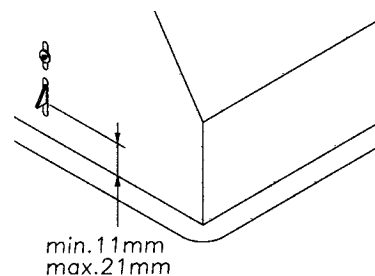

FIG.5

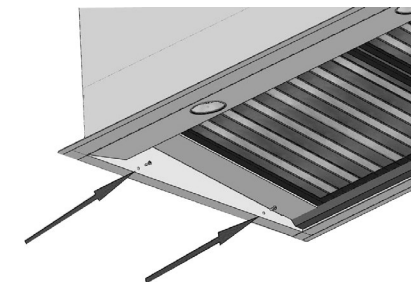

FIG.6

### WARNING:

Before connecting the flexible exhausting pipe to the motor, make sure the stop valve, which is on the air outlet of the motor, can open and close freely.

The cooker hood should be placed at a minimum distance of 65-76cm above the hob. It is the manufacturer of the hob who determines the clearance required and the clearance quoted by the hob manufacturer must be followed. In the absence of any instructions supplied with a gas hob the minimum distance between the hob and the hood must be at least 760mm.

### DUCTED VERSION

- › Connect the flange to the air evacuation hole with appropriate ducting.
- › Connect the appliance to the electrical mains through the supply cord.

### RECIRCULATING VERSION

- › Connect the flange with appropriate ducting to convey the air to the top of the cabinet.
- › Connect the appliance to the electrical mains through the supply cord.

### REAR DUCTED VERSION

- › To duct the appliance to the rear, remove the 18 screws from the motor support.
- › Take the metal support and motor out (Fig.11).
- › Rotate the motor to have the air outlet on the rear side and then fix the screws previously removed (Fig.12).

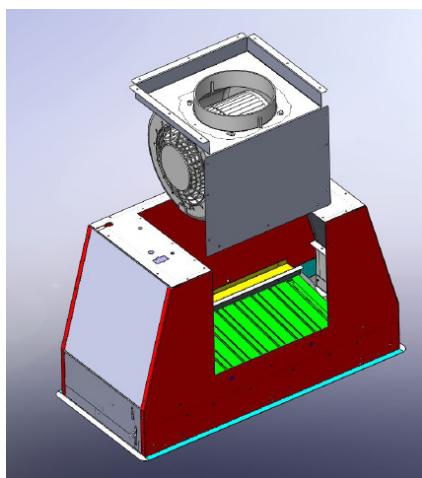

FIG.11

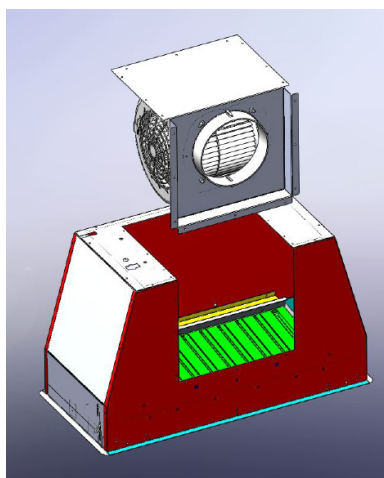
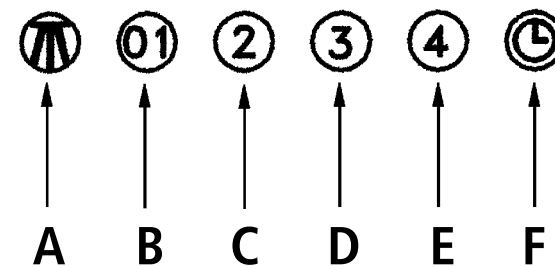

FIG.12

### CONTROL PANEL



- A. Light switch on/off
- B. Motor switch - speed 1 / OFF
- C. Motor switch - speed 2
- D. Motor switch - speed 3
- E. Motor switch - speed 4
- F. 10-minute timer

### AUTOMATIC TURN OFF

After 4 hours of continuous working from the last function selection, the appliance automatically turns off.

## TIMING

---

- › This product is equipped with intelligent electronics which include a timer device for speed controls when the air capacity exceeds 650m<sup>3</sup>/h. Internal motor models, with maximum air capacity higher than 650m<sup>3</sup>/h, are equipped with a timer device that automatically switches the speed from 4th to 3rd speed, after 5 minutes operation.
- › External motor models are equipped with remote motors that, as for internal motor versions, include a timer device that switches down the speed when it exceeds 650 m<sup>3</sup>/h. (See External Motors Instructions). Remote motors, whose air capacity exceeds 650m<sup>3</sup>/h at both 4th and 3rd speed, will have the following by default timer control functions: The speed is automatically switched from 4th to 2nd speed, after 6 minutes operation.
- › If the appliance is working at 3rd speed, it is automatically switched to 2nd speed, after 7 minutes operation. Operation speeds can also be changed during operation. The energy consumption of the appliance in standby mode is lower than 0.5W.

## CLEANING AND MAINTENANCE

---

- › Accurate maintenance guarantees good functioning and long lasting performance.
- › Particular care must be made when handling the grease filter panel. It can be removed by pushing its handle toward the back-side of the cooker hood and turning the filter downwards so to unfasten it from its slot (Fig.3). To insert the filter just perform the opposite operation.
- › After 30 hours of use, the control panel will signal the saturation of the grease filter by illuminating all the buttons. Press the timer button ⊖ to reset.
- › The grease filter needs cleaning regularly by hand or in the dishwasher, at least every two months or more depending on use.

### NOTE:

If washing the grease filter in the dishwasher, wash separately to prevent food particles becoming trapped in the filter mesh.

- › When the appliance is used in recirculating mode, the active charcoal filter (Fig.7) needs to be periodically replaced. The charcoal filter can be removed by removing the grease filter first (Fig.3), and by pulling its special plastic tongue until it is unfastened from its slot. Reinsert the charcoal filter by performing the opposite operation.
- › The active charcoal filter will need replacing depending on the use, but at least every six months. To purchase replacement charcoal filters (ST523: 2 x CAP54CF, ST853: 2 x CAP65CF) please visit [www.caple.co.uk](http://www.caple.co.uk).

## REPLACING LED LIGHTING

### LIGHT SOURCE ENERGY CLASS

This product contains a light source of energy efficiency class F.

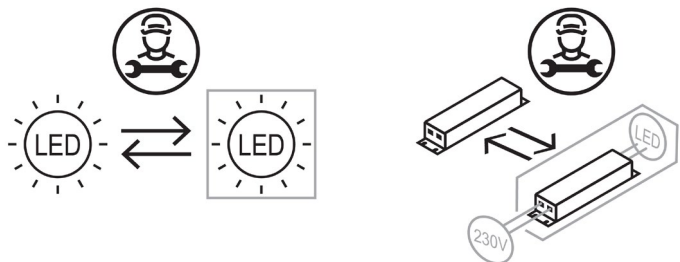

 The LED light must be replaced by an authorised engineer or similar only. For more information, please contact Caple service - 0117 938 7420 or [service@caple.co.uk](mailto:service@caple.co.uk)

 Unplug the unit from the power supply before starting the process.

1. Carefully insert a flat screw driver into the edge of the LED light.
2. Remove the LED light from its housing.
3. Disconnect the connector and change the LED light.
4. Implement the steps in reverse order.
5. After waiting 5 minutes, plug in the unit.

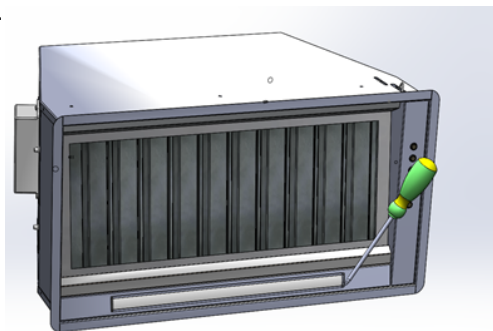

- › To clean the appliance itself, tepid water and neutral detergent are recommended, while abrasive products should be avoided. For steel appliances specialised detergents are recommended (please follow the instructions indicated on the product itself to obtain the desired results).
- › If the supply cord is damaged, it must be replaced by the manufacturer or its service agent or a similarly qualified person in order to avoid a hazard.

### WARNING:

To uninstall the appliance from the cabinet, remove the fixing screws using a screwdriver, remove the grease filters and the active charcoal filter if they have been fitted. Press on the small handle of the springs (inside the appliance) with the necessary force to unhook the appliance from the cabinet.

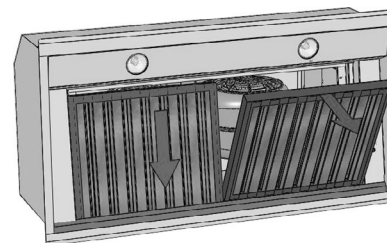

FIG.3

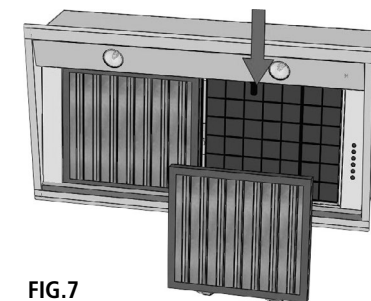
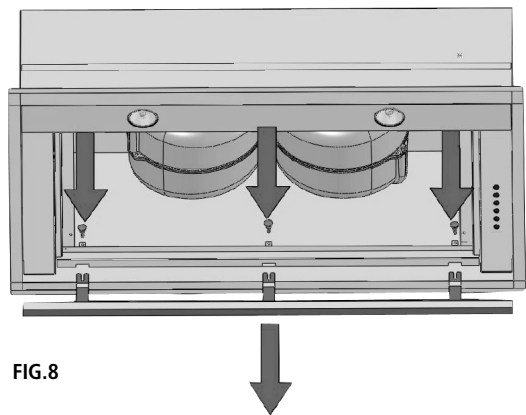

FIG.7

**REMOVING THE OIL CATCHER:**

After having removed the grease filters and the charcoal filters, please hold the oil tank up by one hand and loosen the three handles by the other hand (Fig.8). Then let the tank slide downwards taking care to avoid spilling any oil.

**FIG.8****NOTES:**



Caple Service  
Fourth Way  
Avonmouth  
Bristol  
BS11 8DW

T: 0117 938 1900  
E: [service@caple.co.uk](mailto:service@caple.co.uk)  
[www.caple.co.uk](http://www.caple.co.uk)