



# WI6230

Caple 60cm wine cabinet



**Technical information**

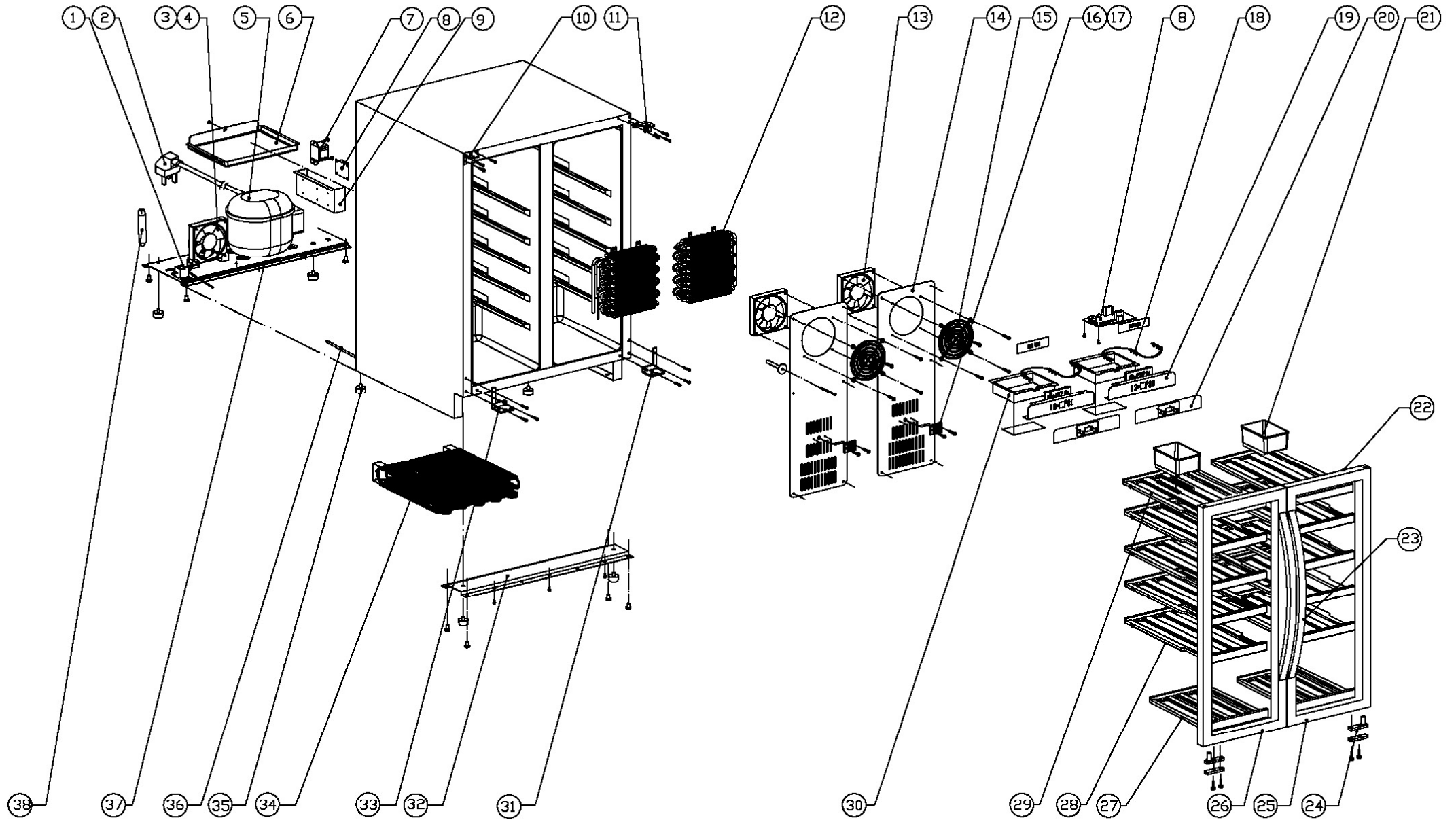



## WI6230 - Caple wine cabinet

| Item | Part Code   | Description                   | Qty |
|------|-------------|-------------------------------|-----|
| 1    | DG12-37.1   | Refrigerant valve             | 1   |
| 2    | DG2-14      | Power cord                    | 1   |
| 3A   | DG7-47      | Condenser fan                 | 1   |
| 3B   | DG17-145-2  | Electric wire                 | 1   |
| 4    | DG19-3      | Fan cover                     | 1   |
| 5A   | DG1-93      | Compressor                    | 1   |
| 5B   | DG12-145    | Start Device                  | 1   |
| 5C   | DG12-146    | Overload Protector            | 1   |
| 6    | DG13-403    | Water tank                    | 1   |
| 7    | DG6-19      | Transformer                   | 1   |
| 8    | DG3-97-6    | PCB board                     | 1   |
| 9    | DG13-272-1  | junction box                  | 1   |
| 10   | DG14-190-SL | Top hinge module (Left)       | 1   |
| 11   | DG14-190-SR | Top hinge module (Right)      | 1   |
| 12   | DG12-44-2   | Evaporator                    | 2   |
| 13   | DG7-48      | Evaporator fan                | 2   |
| 14   | DG22-209    | Air duct board                | 2   |
| 15   | DG19-6      | Fan cover                     | 2   |
| 16   | DG13-198    | Senser cover                  | 2   |
| 17   | DG8-8       | Senser                        | 2   |
| 18   | DG3-12-W    | LED Light                     | 2   |
| 19   | DG13-383    | Display holder                | 2   |
| 20   | DG20-384    | Display panel                 | 2   |
| 21   | DG13-1.2    | Humid box                     | 2   |
| 22   | M160-049    | Gasket                        | 2   |
| 23   | DG22-3064   | Handle                        | 2   |
| 24   | DG22-3057   | Door axis                     | 2   |
| 25   | DG23-172-1R | Door (Right)                  | 1   |
| 26   | DG23-172-1L | Door (Left)                   | 1   |
| 27   | DG15-27     | Wooden shelves C1             | 2   |
| 28   | DG15-26     | Wooden shelves A15            | 8   |
| 29   | DG15-26.1   | Wooden shelves A15A           | 2   |
| 30A  | DG22-395    | Electrical box                | 2   |
| 30B  | DG13-353    | Sealing strip                 | 2   |
| 31   | DG14-212-SR | Lower hinge module (Right)    | 1   |
| 32   | DG22-330    | Support bracket of front legs | 1   |
| 33   | DG14-212-SL | Lower hinge module (Left)     | 1   |
| 34   | DG12-91-2   | Condenser                     | 1   |
| 35   | DG13-3146   | Cabinet leg                   | 4   |
| 36   | DG12-113    | Air-circulating pipe          | 2   |
| 37   | DG22-331    | Compressor bracket            | 1   |
| 38   | DG11-46     | Drier filter                  | 1   |
| -    | DG22-3021   | Decorative frame              | 1   |
| --   | DG22-3302   |                               | 1   |
| ---  | DG22-3303   |                               | 1   |



WI6230

Caple 60cm wine cabinet

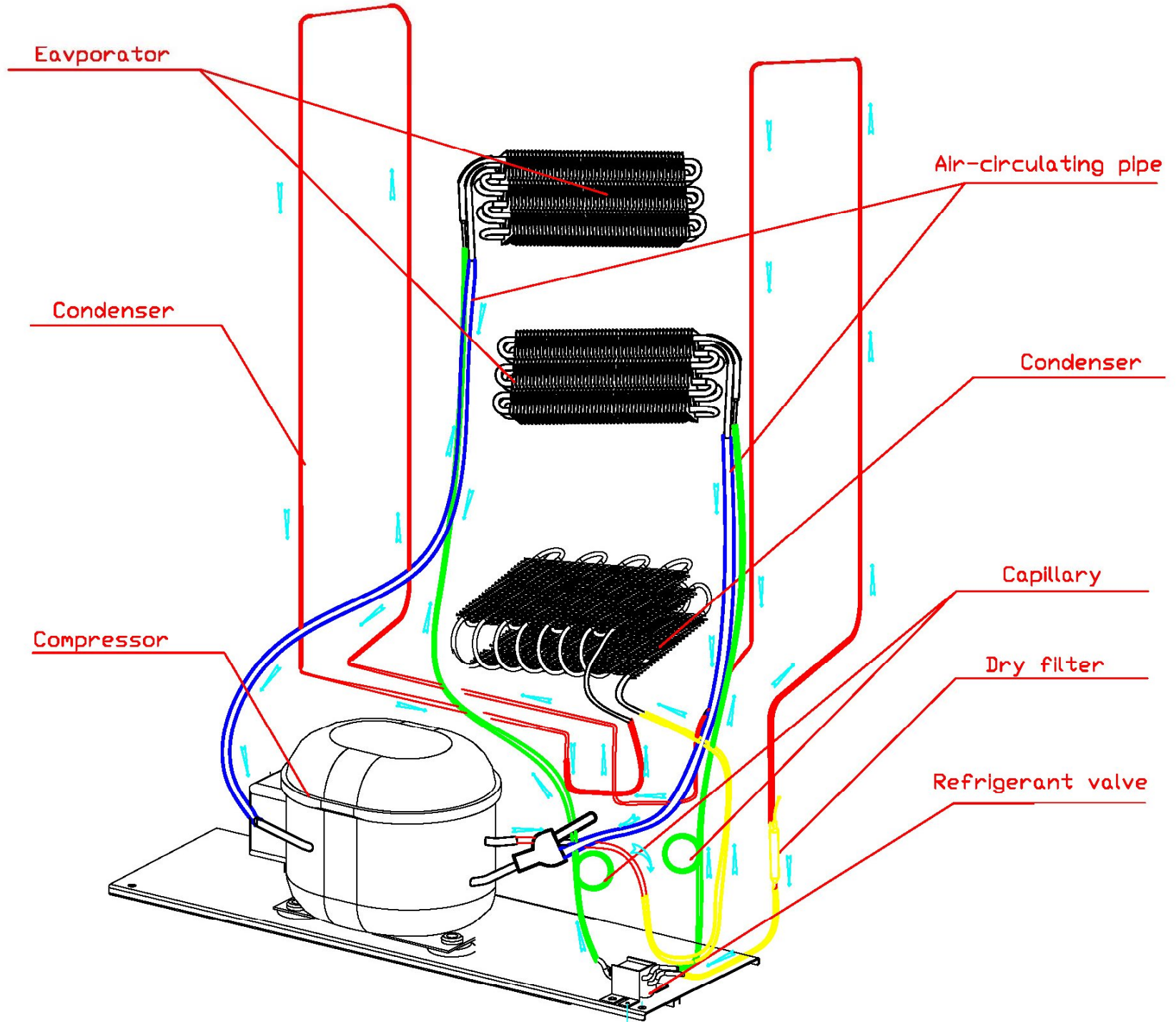

Computer Controlled Synchronous Dual Temperature  
Wine cooler JG2D1

**service manual**

Here below we list various faults while using the wine cellar, and the method of check-up and solve these defaults, please find the information of the correspondent page.

---

Statement: (Fig.4 ) shows the reference figure Fig4  
( →6 ) shows the reference page 6

**Warning:**

- 1. Before attempting any cleaning or maintenance this unit MUST be disconnected from the electrical supply, to prevent electrical shock.**
  - 2. Before using the welding torch please make sure that there isn't any gas in the cooling systems.**
  - 3. Before using the welding torch please do the necessary protection well. When servicing the wine cooler with R600a systems, please make sure the ambient is well ventilated.**
- 

▲ Preparation before maintenance

○ Tools

- |                           |                     |
|---------------------------|---------------------|
| 1.Plier                   | 2.Cross-screwdraver |
| 3.Assistant pipe          | 4.Multimeter        |
| 5.Clamp ampere meter (5A) | 6.Electric iron     |
| 7.Wire insulator stripper | 8.Pipe seal plier   |

○ Equipment

- |               |                               |                     |
|---------------|-------------------------------|---------------------|
| 1.Vacuum pump | 2..Cope pipe welding facility | 3.Refrigerant meter |
|---------------|-------------------------------|---------------------|

▲ Cooling systems fault

- How to diagnose the faults.....(→2)
- How to maintain the faults .....(→2)
- How to remove the air-duct boards.....(→3)
- Diagram showing the front side soldered joints.....(→5)
- Diagram showing the back side soldered joints.....(→5)

▲ Noise problem

- Compressor noise .....(→6)
- Fan noise.....(→6)
- Refrigerant jet noise .....(→7)
  
- Capillary vibration noise .....(→7)
  
- Oil jam noise .....(→7)

▲ Evaporator freezing .....(→8)

▲ The unstable of the wine cooler temperature .....(→8)

▲ The control system fault

- Fault finding by self-check mode.....(→8)

- Sensor fault .....(→9)
- How to replace the sensor.....(→10)
- Refrigerant valve fault.....(→10)
- LED display fault .....(→11)
- How to remove the parts inside the control PCB electrical box .....(→11)
- The name and explanation of the control PCB and power PCB board connectors.....(→12)
- How to remove the power PCB and transformer .....(→13)
- How to replace the LED light.....(→14)

▲ The control system fault

- How to diagnose the faults

It should take approximate 3 hours to reach the lowest setting temperature of 5°C for an empty unit in both zone (assuming ambient temperature of 32 degrees centigrade and continuous operation). If not, check the compressor, cooling fans, controller, and sensors. If all these are working normally, there is probably a cooling system fault.

- How to maintain the faults

1. Check the compressor:

The process of compressor removed: remove the electrical box of compressor→disconnect the connectors to the compressor→separate the pipe joints→remove the compressor

The process of evaporator removed: remove the shelves→remove the airduct board→separate the pipe joints→remove the evaporator

If neither zones can not refrigerate, check the current of the compressor with a clamp Ampere meter, and the current should be within 0.8 to 2 A. If the current not in this range, turn off and cut off the exhaust(Fig.4 ,see point D) and assistant pipe(Fig.4 ,see point A), electrified the wine cooler and check the current again, check the discharge pipe of the compressor at the same time, if it has an clear air pressure, if the electricity is still too high or has not air pressure, it shows that the compressor is failed by itself, and you need to replace the compressor. (Noted: To avoid the compressor suck the moist,run the compressor not longer than 15 minutes after the assistant pipe and discharge pipe cut off.)

2 . Check the cooling system pipe work.

1>.Under the condition of the compressor running normally, neither zone is not cooling. and it is possibly that the cooling system pipe leak. The maintain procedure is following.

- a. Cut the discharge pipe of the compressor. infill 0.8-1Mpa nitrogen via assistant pipe, and feel the discharge pipe, there should be a little airflow which means the capillary is normal, otherwise the capillary is jam.
- b .Make sure the capillary is in good condition, join the discharge pipe, infill 0.8-1Mpa nitrogen via the assistant pipe, check all the joints with soap water if any leak from any of them. Check the back side joints around the compressor first (Fig.4),if it without any leak check front side joints(Fig.3 ).Before checking front side joints you need to remove the airduct board(Fig.1 & Fig.2).
- c. If there isn' t any leakage can be found, it means two possible:1.the internal leakage,2.the evaporator or other part leakage. Internal leak can' t be repaired, if the part (such evaporator, condenser) leakage, replace it please.
- d. Confirming the cooling system is in good condition, you refill again.

2>. Under the compressor is running normally, if only one zone no cooling, the fault should happen on the part in this zone.(two zones have the same structure, so the maintain method for them are same).

a. Check the valve by hearing the sound. turn off the wine cooler and exchange the connectors of the valve then power on, listen carefully you can hear the snip-snap sound from valve, otherwise the valve is power off or broken or the PCB fault. Confirming the PCB is normal, replace the valve. (→8) (Fig.9)

b. If the valve is running normally, it maybe the capillary jam, please clean it with nitrogen, you can overhaul it refer to above.

c. Replace the fault spear parts. Confirming the cooling system is not jammed, refill the refrigerant.

### 3 . Refill

1>. Using the vacuum pump form a vacuum in the system, via the joint of the low-pressure pipe (Fig.4,see point A), the high-pressure pipeline is on the process pipe of the filter. Apply the vacuum pump for approximately 20 minutes. Until the vacuum is lower than 100Pa. Then solder the process pipe of the filter Keep the the system vacuum.

2>. Fill Cooling system with refrigerant via the process pipe (Fig.4,see point A). The refrigerant and quantity Please refer to the instruction at back label of wine cellar. Then solder the compressor process pipe after the system is charged with refrigerant.

### 4 . Test

Replace all the components after the procedures above and turn the unit on. To verify the effectiveness of the repair, monitor the unit, the compressor should automatically stop when both zone 1.5°C lower than setting temperatures and start when either zone 2.5°C higher than setting temperature within approx 3 hours (assuming an ambient temperature of 32°C and the unit is empty).

#### ○ How to remove the air-duct boards

1>. Pull the shelves to the bottom, circumvolve any side of the right and left, and let the setter of the shelve go out of the channel, and then draw out the shelves. (Fig.1)

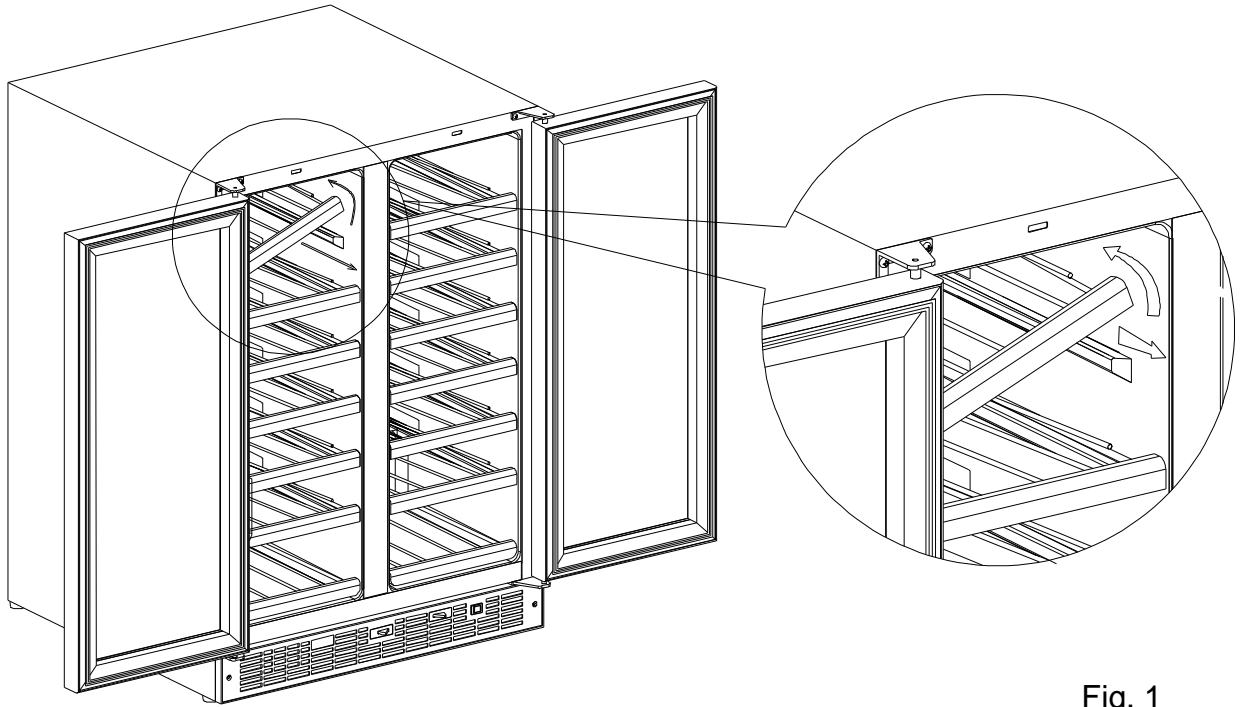

Fig. 1

2>. Use a Set of cross-screwdrivers to remove the air-duct board screws (Note: 1~5 are the air-duct board screws. A~D are the fan screws, need not to remove), and remove the air-duct board. Be attention to unplug the connection wire when removing the air-duct board. You can move slowly aside until you can see the fans wire, and unplug the fan connector, and then take out the whole air-duct board. ;(Fig.2)

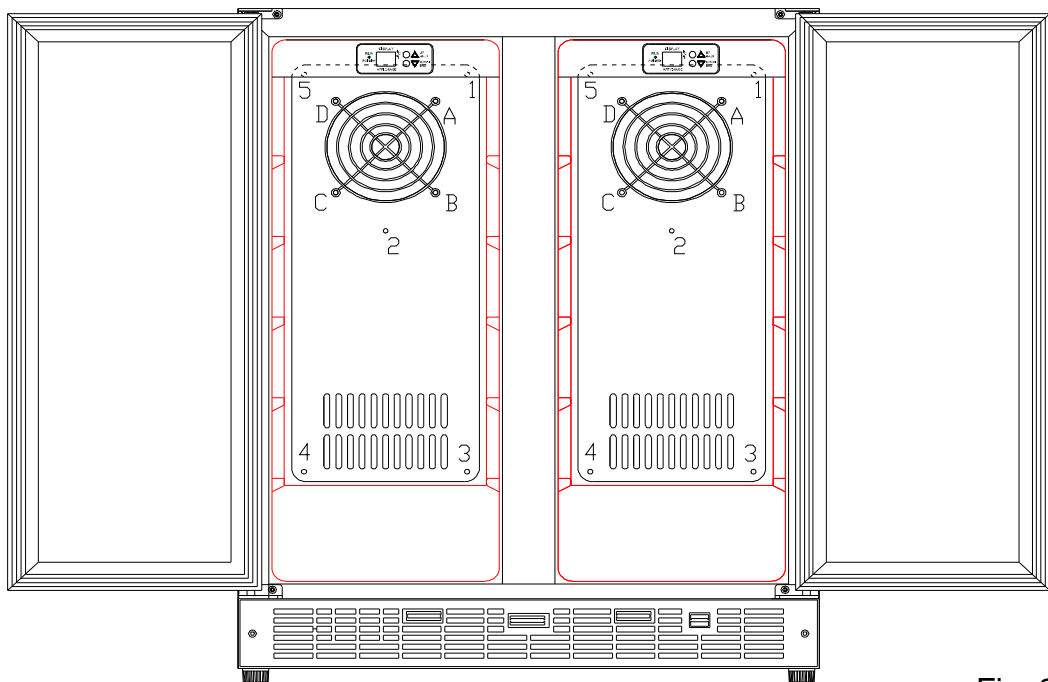

Fig. 2

3>. The picture after removing the airduct board. (Fig.3 )

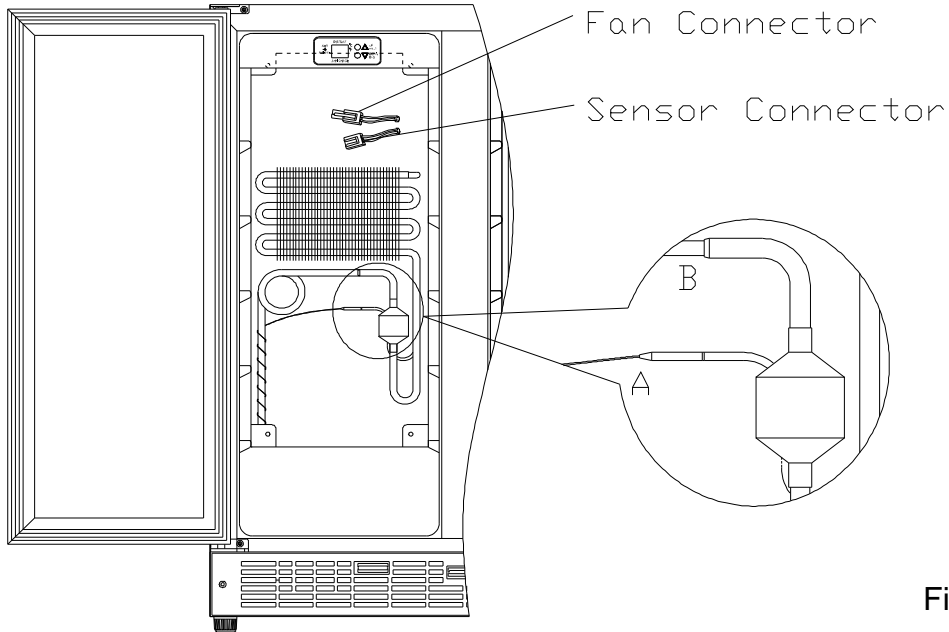

Fig. 3

○ Diagram showing the front side soldered joints(Fig.3 )

A: Capillary soldered joint

B: Evaporator soldered joint

○ Diagram showing the back side soldered joints(Fig.4 )

A: Compressor assistant pipe soldered jointed

C: Right zone suction pipe soldered joint

E: Left zone suction pipe soldered joint

G: Filter soldered joint

Connector pipe joint

K: Left zone capillary soldered joint

B: Anti-dew pipe soldered joint

D: Discharge pipe soldered joint

F: Condenser soldered joint

H: Right zone capillary soldered joint I:

J: Valve soldered joint

L: Condenser soldered joint

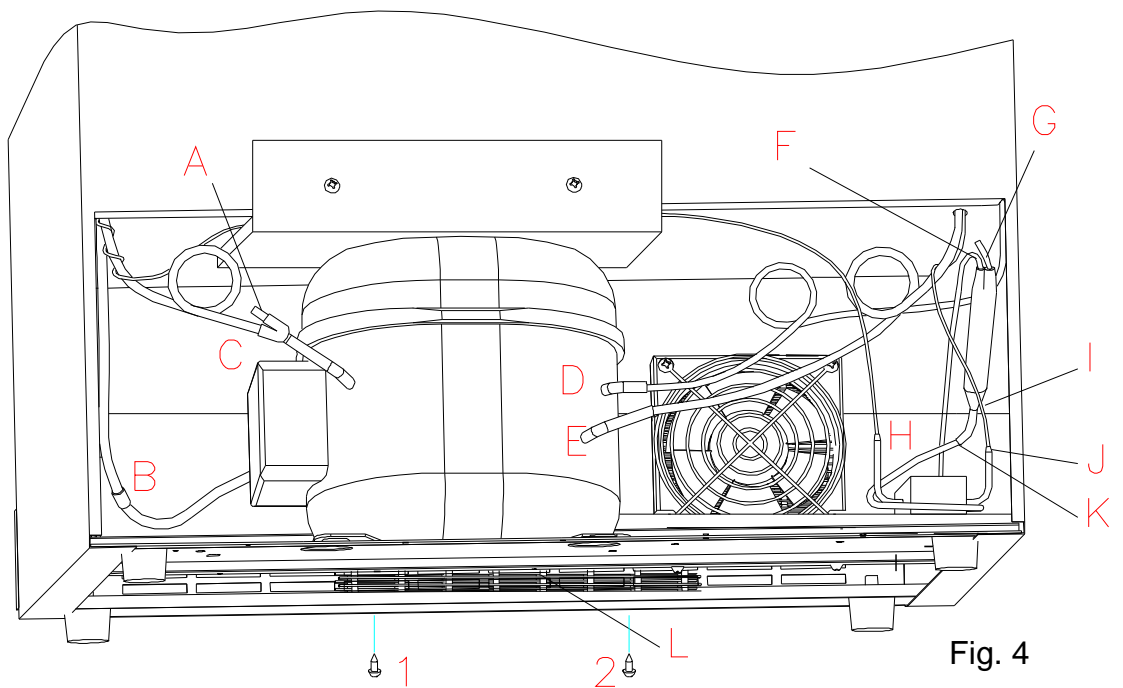

Fig. 4

## ▲ Noise problem

### ○ Compressor noise

- 1>. The working of motor and piston motion will cause noise when compressor working. So if noise is steady and not exceeds 42 dB, it's normal. If noise is not steady or very high, it's compressor fault and it should be maintained or replaced.
- 2>. If compressor's shock absorption rubber is hardening or damaged, or fixing screw of compressor is too tight or loose, it will cause noise. The settlement is to change new shock absorption rubber or adjust fixing screws.

### ○ Fan noise

- 1>. The running of the fan motor will cause noise because the vane circumsolve in high speed and the airflow. Normal fan motor and airflow should not exceed 32 dB.
- 2>. If the noise is extremely big , there maybe the fan's fault, the reason is following:
  - a. The axletree of the fan broken
  - b. The bad balance because the fans abrasion

3>. The fan can be replace with another same model's fan, the procedure is following:

a. How to replace the evaporator fan .

The process of evaporator fan removed: Remove the shelves→remove the airduct board→disconnect the connectors →remove the fan cover remove the fan.

1>. Remove the shelves. (→3) (Fig.1)

2> . Remove the air duct board. See (→3) (Fig.2)

3>. Remove screws (A, B, C, D), then replace the evaporator fan See (Fig.2 & Fig.5)

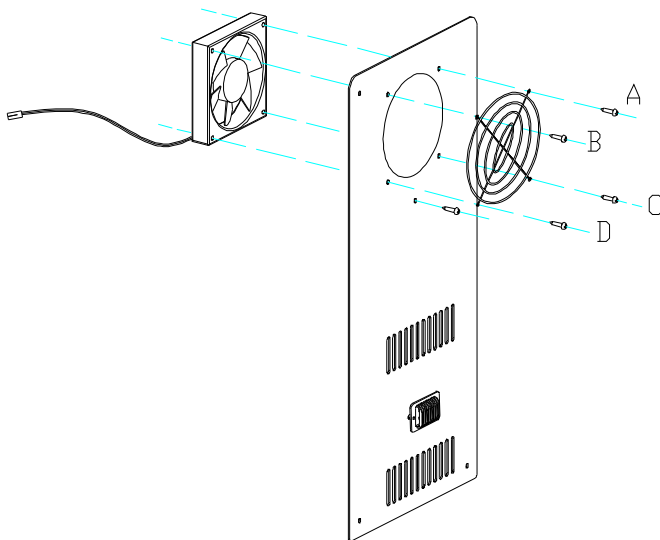

Fig. 5

b. How to replace the condenser fan:

1>. Remove the screws(3,4) ,take apart the electrical box (A) ;(Fig.6)

2>. Pull off the of the fan connector on the power PCB. (Fig.13)

3>. Lean back the cabinet 45°, or put it on the workbench, and use a Set of cross-screwdriver to wrest off the two screws(1,2) of compressor bottom penal, and remove the condenser fan to replace with a new one. (Fig.6 & Fig.6.1)

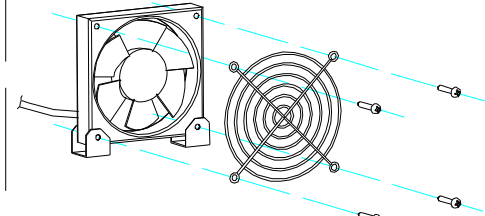
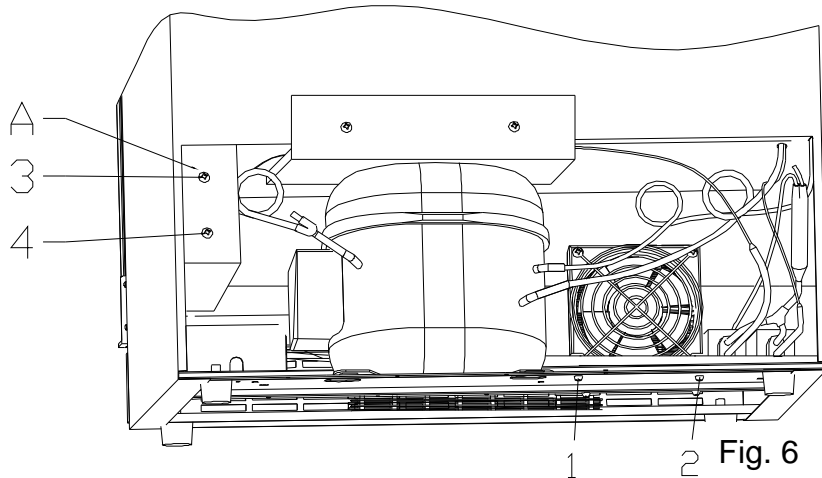

Fig. 6

Fig. 6.1

○ Refrigerant jet noise

Fault: a continuous noise like a water spray from the capillary.

Causation: the end of the capillary is in the wrong position, or there are rough edges on the end of the capillary.

Solution :

- 1>. Heat the soldered joint of the capillary (Fig.3 showing A point), then remove the capillary from the evaporator and smooth the end with an eraser. (Caution: do not allow any particles into capillary unit).
- 2>. Replace the capillary into the evaporator, then solder it back into the correct position (not exceeding 15mm in the evaporator) and pack the joint with anti vibration compound.
- 3>. Vacuumize and recharge with refrigerant. See (→2)

○ Capillary vibration noise

Fault: high frequency impact noise in capillary Zone. Caused by either

Causation:

- 1>. The capillary being insert too deep into the evaporator, so when the refrigerant is Jetting, the end of vibrating capillary will hit the inside of the evaporator.
- 2>. Vibration from the capillary touching the inside of the cabinet or air duct board, then when refrigerant is jetting.

Solution:

- 1>. If the capillary is inserted too deep, heat it with the solder, solder it again(Please noted, the deep inserted is not bigger than 15mm), and vacuumize it and add the refrigerant. (→2)
- 2>. If the capillary touch the inner cabinet or the air duct panel, adjust the position of the capillary and add the incabloc plastic. (Fig.3)

○ Oil jam noise

Fault: intermittent and deep jet noise coming from inside of the capillary.

Causation: Compressor oil flowing into the cooling system pipe work probably due to the unit leaning during

transportation, and the oil form the jetting noise in the capillary.

Solution: Clean the cooling system pipe, and recharge with refrigerant see (→2)

### ▲ Evaporator freezing

○ Because the gasket is not air-proof, or the door is not closed well, cause much water fill in the the cabinet, and the water got frozen when it encounter the cold air, sometimes the ice is too thick, and it will block the fan or broken the fan.

The solution:

1>. Replace the door gasket or close the door well. If the door gasket is slightly not air-proof, it can be repaired by the heat dryer.

Aiming at the distortion of the gasket with the heat dryer, and move up and down or right and left until it expand to the normal state. When it is cool, check it with the door closed, if there is any distortion, dry it again until it fix for the door. (Fig.7)

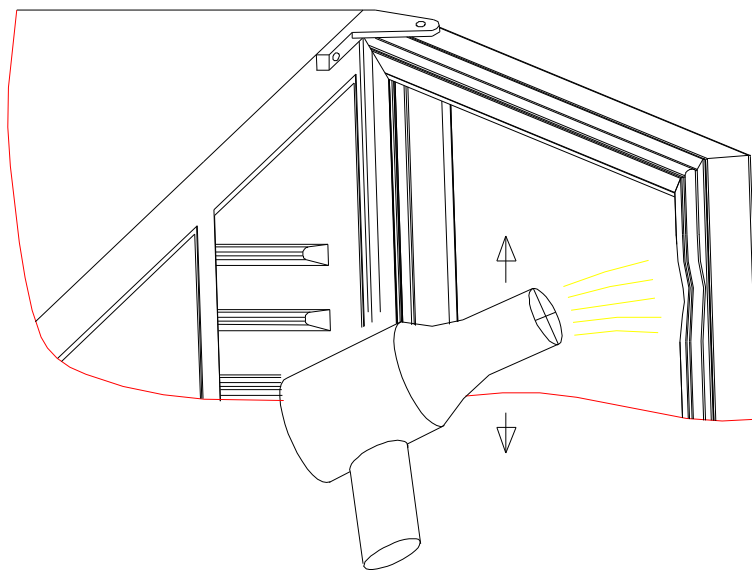

Fig. 7

### ▲ The instability of the wine cooler temperature

The unstable temperature is caused by the evaporator fans cease, and it can be check by the below method: When the compressor is running, the light “Run” is on, the fan should be running, if the fan stop, check whether is any fault in the fan or fan connection. If the fan is broken, replace it with the fan of the same model. (Fig.5)

### ▲ The control system fault

○ Fault finding by self-check mode

This series wine cellar has a computerized controller with built in self-check function. Start the self-check mode as follows:

1>. Press and hold “Set lower” and “Set upper” button with power on. 3 beeps will sound, and then the controller will start the self-check function.

2>. If everything is operating correctly,

a. No response when pressing buttons.

b. LED display “— —”;

c. The compressor works and the “RUN” indicator light are on all the time.

d. The condenser and evaporator fans work at full speed,the valve switch every three seconds;

e. The switch controls the light functions normally.

3 >. If the above a~e point is line in the situation, and every components of the machine is normal; if there is any different, and firstly check the abnormal components and their connection wire. If the connection is tight, replace the components. If the replacement fail, it can be judged as control PCB's fault, please replace it with the same module. (Fig.10 & Fig.11)

4 >. Unplug the plug to exit the self-examination system.

#### ○ Sensor fault

1 >. After turning on the power, if the LED display shows the temperature is similar with the ambient temperature, it is normal, if abnormal, please remove the electrical box, (Fig.10 & Fig.11) (→9), check the sensor insert "X7" or "X8" whether reliable. If the insert is reliable, it is the sensor's fault, replace the sensor with the same module.

2 >. The LED display shows E7, and it is the left zone's sensor open circuit fault, check the connection wire and the main board whether open circuit, if not, replace the sensor with the same module. See(Fig.8.)

3 >. The LED display shows E8, and it is the left zone's sensor short circuit fault, check the connection wire and the main board whether short circuit, if not, replace the sensor with the same module. See(Fig.8.)

4 >. The LED display shows E1, and it is the right zone's sensor open circuit fault, check the connection wire and the main board whether open circuit, if not, replace the sensor with the same module. See(Fig.8.)

5 >. The LED display shows E2, and it is the right zone's sensor short circuit fault, check the connection wire and the main board whether short circuit, if not, replace the sensor with the same module. See(Fig.8.)

6 >. The LED display shows HI, and it is the high temperature protection indication. After running 10 hours with power, if the inner temperature over 23<sup>0</sup>C. the LED display H I. When the HI shows for an hour, then the HI twinkling , buzzer the alarm. And after the HI is continuous to twinkle for 20 minutes more, the compressor will stop working , and it need to be cut off power to stop the alarm. The reason and the solution of this phenomena is as following.

A. If the left and the right side both show HI, the reason is refrigerant leakage cause the cooling fault. Find the leakage point, and weld it again, vacuumize and refill. (→2)

B. If any zone shows HI, the reason is as following:

a. Because the capillary is blocked, not cooling, please do as the above method. (→2)

b. The refrigerator valve damage and can not be switch, cause not cooling, replace with the new one.(Fig.9)

c. The evaporator fan do not move, rapair it.(Fig. 5)

7 >. The LED display shows LO, it is the low temperature protection indication.The principle is when the temperature of the cabinet is lower than 0<sup>0</sup>C, the system start up low temperature protection function, and now the LED display shows LO, and the buzzer alarm, the machine is forced to stop, so as to protect the wine from damage. When the temperature of the cabinet is higher than 0<sup>0</sup>C, the protection will dismiss automatically, and the LED display show the actual temperature.

Note: the LO usually appear when the temperature set between 4~6<sup>0</sup>C, if the temperature set higher than 6<sup>0</sup>C, LO appear, and it is abnormal, the resolution is check whether there is any voltage outlet the refrigerant valve , if no, change the control board.

○ How to replace the sensor

The process of sensor removed: remove the shelves→remove the airduct board→disconnect the connectors→remove the sensor cover→remove the sensor

The sensor are fix on the airduct board(two zone are same)

- A. Remove the shelves. (→3) (Fig.1)
- B. Remove the air duct board. See (→4) (Fig.2)
- C. Push and then pull out the two plastic nails(1,2),the sensor cover(3) come loose, disconnect the connector(5) of the sensor, and replace it(4). ( Fig.8)

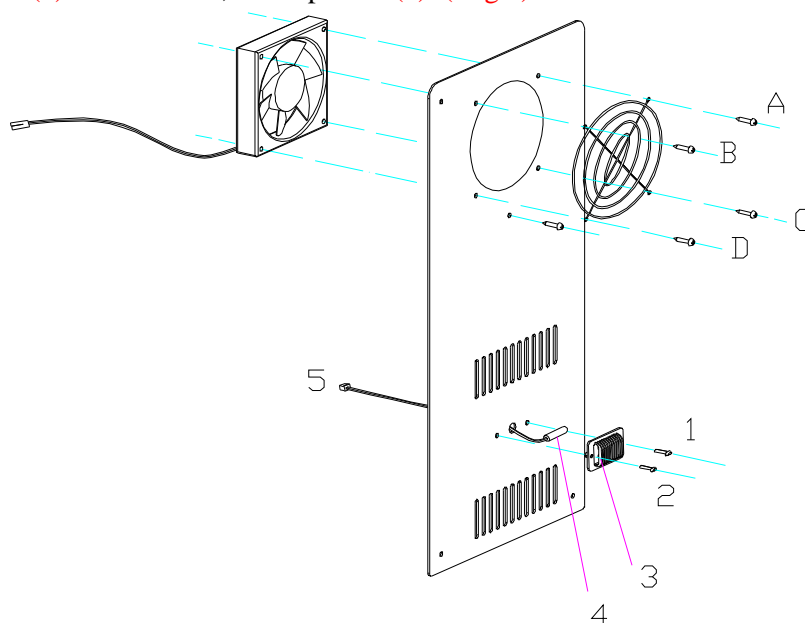

Fig.8

○ Refrigerant valve fault

The process of valve removed: remove the cover of the valve→disconnect the connectors→disjoin the soldered joints→remove valve

- 1 >. If the temperature of either zone of left and right is normal, and another zone is not cooling, or over low temperature, (lower than the temperature preset 3℃), or one zone is not cooling the other zone is over cold, please check the refrigerant valve.
- 2 >. Turn off the power, exchange the two poles of the refrigerant valve, and turn on the power again, please pay attention to the sound snip-snap, or the refrigerant valve out off power or ruins. Replace the same module's refrigerant valve when confirming the PCB board is normal.
- 3 >. How to replace the refrigerant valve:
  - A. Use welding facility to heat the 3 welding point H, K, J, and then take off the refrigerant valve. (Fig. 9)
  - B. Use the cross screwdriver to wrest the refrigerant welding screw 1 (totally 2pcs, another isn't show in the picture.) ; (Fig.9)
  - C. Replace with the new refrigerant valve, and vacuumize it, and refill refrigerant, complete the replacement.

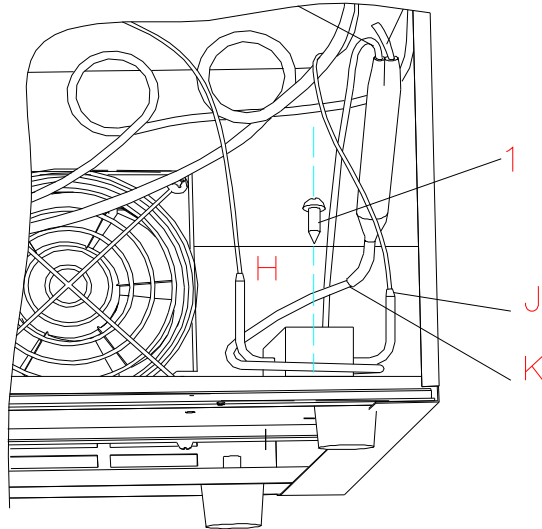

Fig. 9

○ LED display fault

This fault caused by led displayer broken, just change it will be OK. (Fig.10 & Fig.11)

○ How to remove the parts inside the control PCB electrical box (notice, the main PCB is installing in the electrical box in right zone)

The process of main PCB removed: remove all the shelves in right zone→take apart the electrical box in right zone→disconnect all connectors→remove the main PCB

The process of display PCB removed: remove the shelves→take apart the inner electrical box→disconnect all connectors→(if necessary remove the main PCB) →disconnect the ribbon cable→remove the display PCB

1 >. Remove the shelves ;( Fig.1)

2 >. Screw the two bolts out from the electrical box (3, 4), half loose the two bolts(1, 2) which in the front of the box, pull the electrical box out ( Fig.10 )

3 >. The explode drawing of replaced electrical box is below; ( Fig.11)

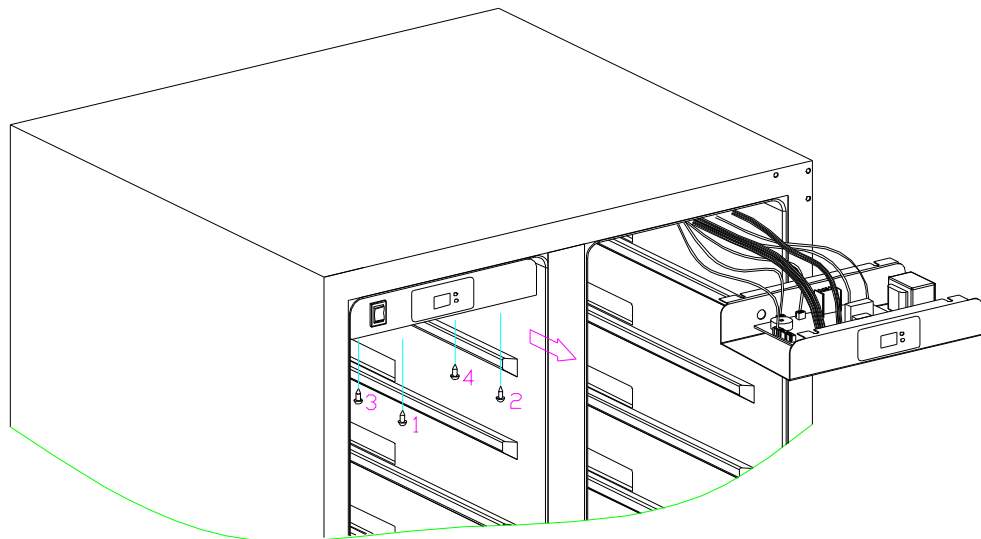

Fig. 10

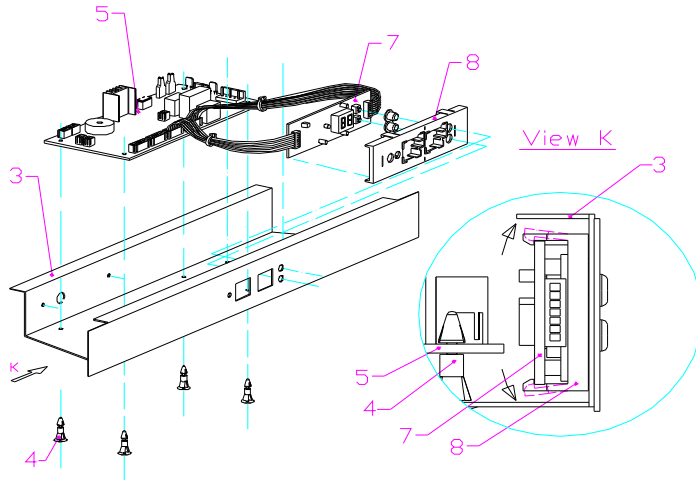

Fig. 11

- 4 >. Unplug all the connectors, then press the head of each of the four plastic studs (4) one by one, and move up-ward the control board, remove the control board, and replace it with the new module. See. ( Fig. 11)
- 5 >. Replace the LED display board. Unplug the four 4 display cover fasteners on display board supporter (8) as per arrowhead direction, and then remove the display board, and its two connectors from both sides, Replace the display board. See ( Fig. 11 & Fig. 12)

○ The name and explanation of the main PCB board connectors(Fig. 12)

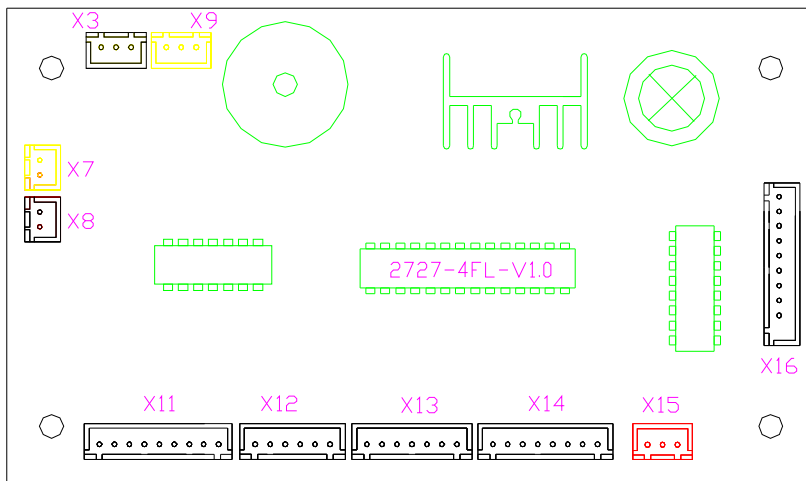

Fig. 12

- X7: To right zone sensor(yellow)
- X8: To left zone sensor(white)
- X9: To right zone fan(yellow)
- X3: To left zone fan(white)
- X11、 X12: To left zone display PCB
- X13、 X14: To right zone display PCB
- X15: To LED light (red)
- X16: To power PCB

○ The name and explanation of the power PCB ( Fig. 13)

1. To PTC heater (white)
2. To transformer primary (L)
3. To transformer primary(N)
4. To the main power N
5. To the main power L
6. To the compressor
7. To the valve
8. To the main PCB(white)
9. To the condenser fan(Red)
10. To the transformer secondary

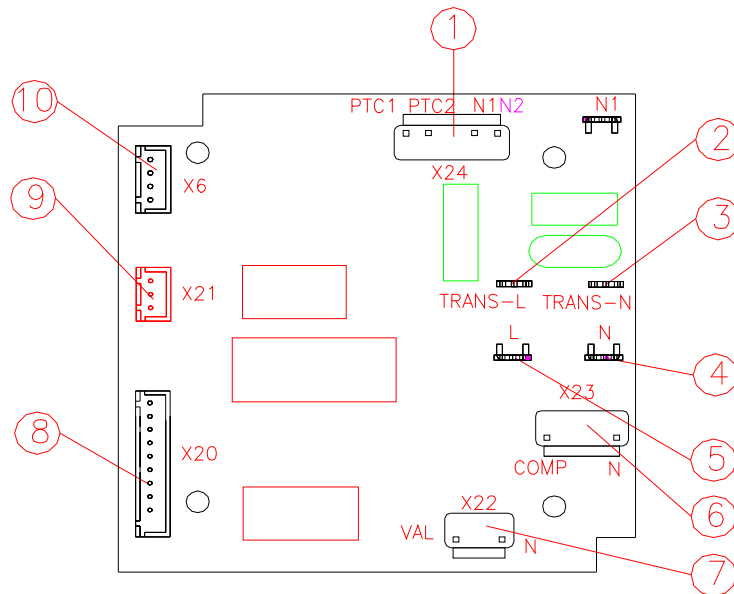

Fig. 13

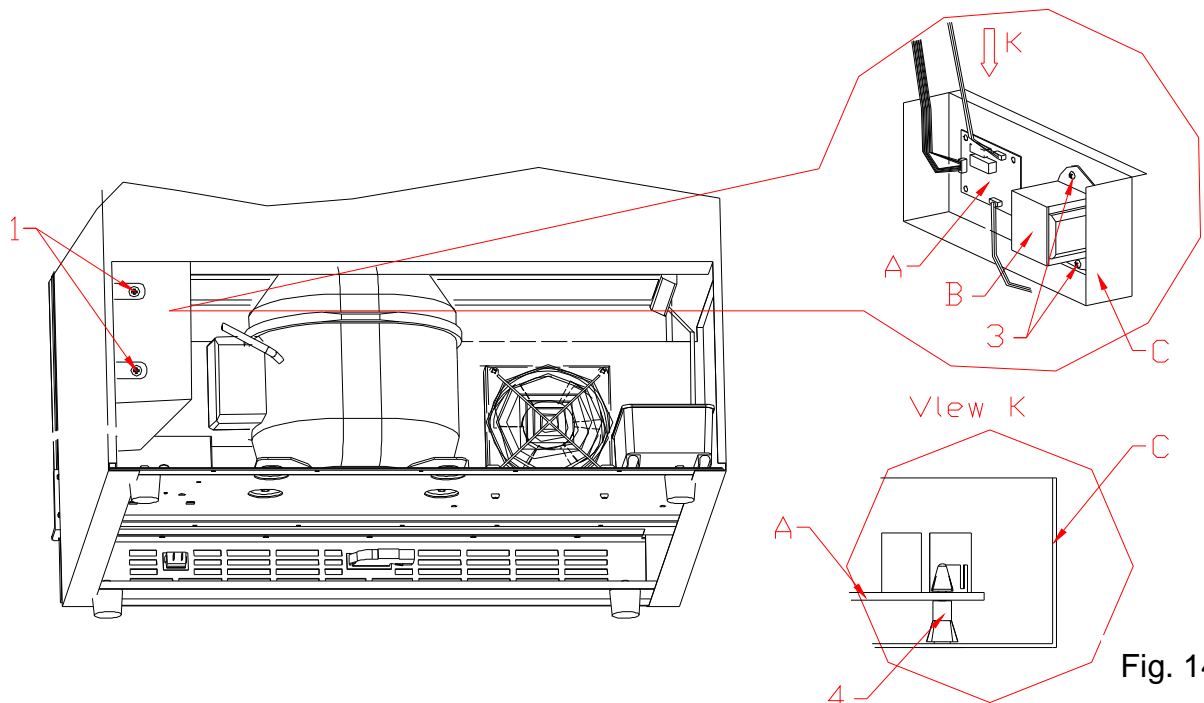

Fig. 14

○ How to remove the power PCB and transformer

The process of power PCB removed: remove the electrical box→disconnect all connectors→remove the power PCB

The process of transformer removed: remove the electrical box→disconnect the transformer connectors→remove

the transformer

- 1 >. Remove the 2 screws (1); ( Fig.14)
- 2 >. Remove the electrical box; ( Fig.14)
- 3>. Unplug all the connectors, then press the head of each of the four plastic screws (4), move up-ward the power PCB (A), then replace a new one. ( Fig.14) (View K)
- 4>. Plug all the connectors; ( Fig.13)
- 5>. Remove the 2 screws (B) and transformer, then replace a new transformer.( Fig.14)

○ How to replace the LED light

The process of LED light removed: remove all shelves in the zone→take apart the inner electrical box→disconnect light connector→(if necessary remove the main PCB) →remove the LED light

- 1>. Follow the removing methods to remove the PCB board; (Fig.10 & Fig.11)
- 2>. Then you will see the LED light is divided in to 3 parts, then pull out the line (1)follow the arrowhead's heading; (Fig.15)
- 3>. Pull out fasteners of the LED installed board (B) follow the View K point 1, at the time peak up the LED light board(A), then change the LED light board.

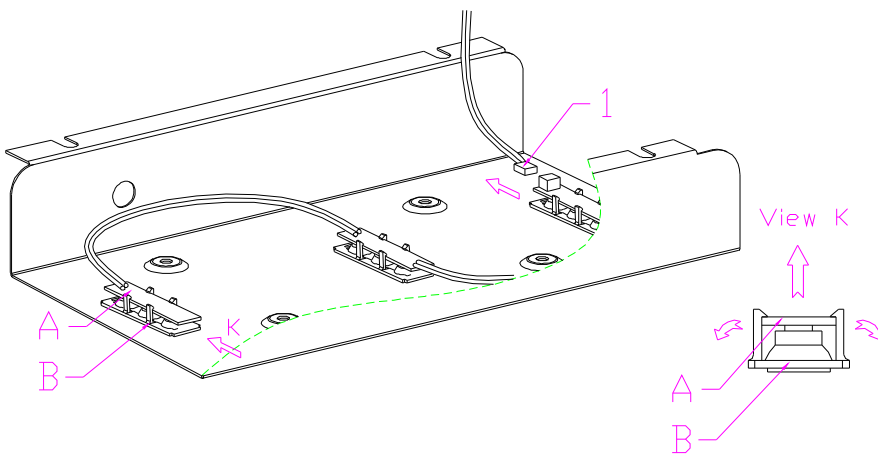

Fig. 15

REV.C