



WI6128WH

Caple 60cm 2 zone wine cabinet



Technical information

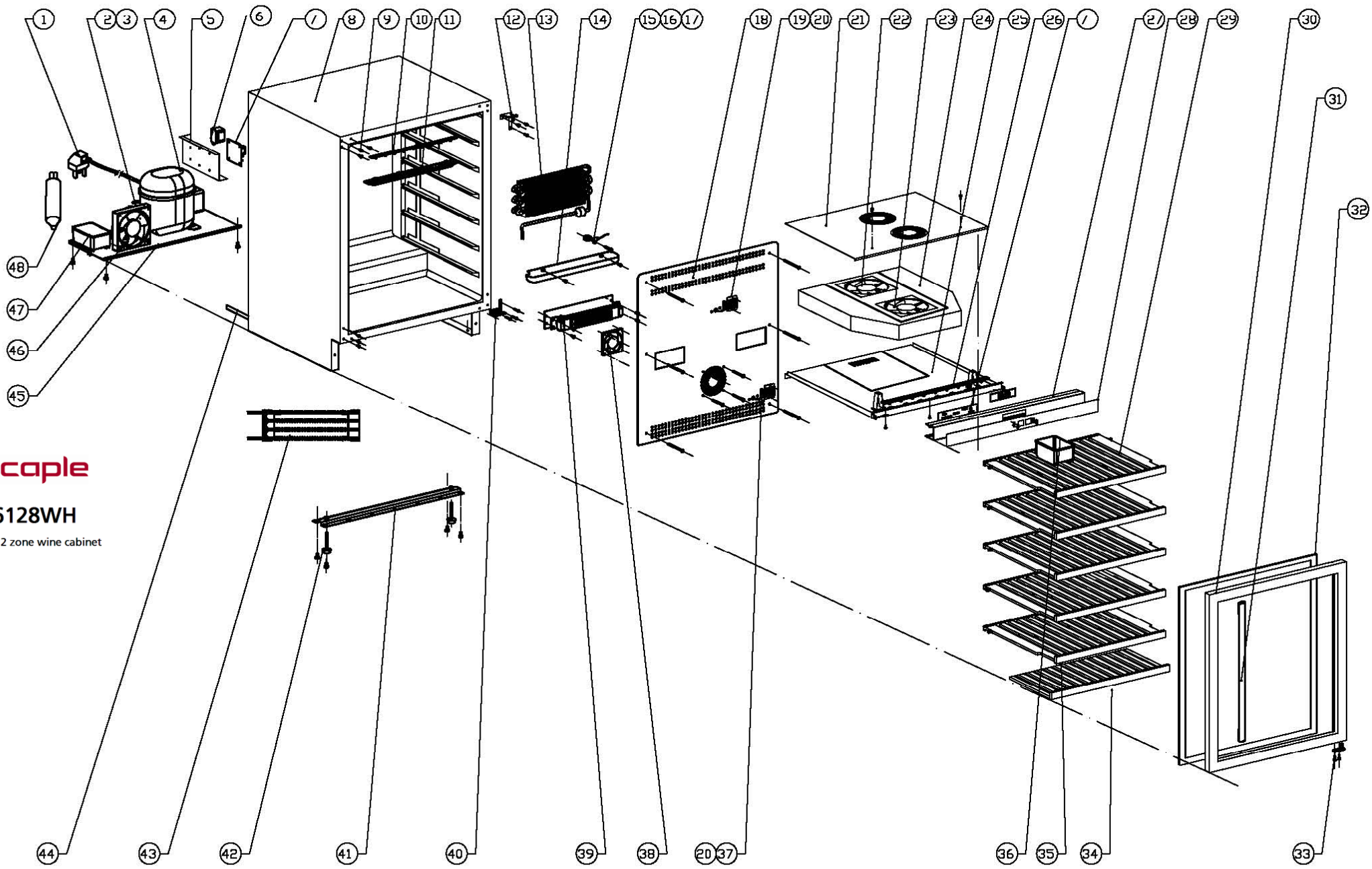

WI6128WH

Caple 60cm 2 zone wine cabinet



WI6128WH - Caple 60cm 2 zone wine cabinet

Item	Part Code	Description	Qty
1	DG2-14	Power cord	1
2	DG7-3.2-BH	Condenser fan	1
3	DG19-3	Fan cover	1
4	DG1-93	Compressor	1
5	DG13-272-1	PCB board cover	1
6	DG6-15	Transformer	1
7	DG3-100-9	PCB board	1
8	DG26-163	Cabinet	1
9	DG13-268	Decorative nail	6
10	DG3-13-W	LED light	1
11	DG13-129	LED light cover	1
12	DG14-190-SR	Top right hinge	1
13	DG12-1-2	Evaporator	1
14	DG13-458	Water box	1
15	DG13-7	Shelf support	1
16	DG20-1	Wire clamp	1
17	DG8-8	Senser	1
18	DG22-422	Air duct board	1
19	DG8-8	Senser	1
20	DG13-198	Senser cover	2
21	DG22-421	Upper panel for middle airway-board	1
22	DG7-3.1-BH	Evaporator fan1	1
23	DG7-3.1-BH	Evaporator fan2	1
24	DG18-76	Foam	1
25	DG22-303	Lower panel for middle airway-board	1
26	DG3-13-W	LED light	1
27	DG13-33	Display support	1
28	DG20-319	Display panel	1
29	DG15-211-1	Wooden shelves A16A NEW	2
30	DG23-260-1	Door	1
31	DG22-3027	Handle	1
32	M184-040	Gasket	1
33	DG14-116	Door axis	1
34a	DG15-33	Wooden shelf G2	1
34b	DG15-45	Stainless steel edged	1
35a	DG15-211	Wooden shelves A16 NEW	3
35b	DG15-23	Stainless steel edged	5
36	DG13-1.2	Humid box	2
37	DG8-23-1	Senser	1
38	DG7-41-BH	PTC heater fan	1
39	DG11-18	PTC heater	1
40	DG14-212-SR	Lower right hinge	1
41	DG22-88	Support bracket of front legs	1



WI6128WH - Caple 60cm 2 zone wine cabinet

Item	Part Code	Description	Qty
42	DG13-6.11	Cabinet leg, type BC50N	4
43	DG12-91	Condenser	1
44	DG12-6.1	Air-circulating pipe	1
45	DG22-80	Compressor bracket	1
46	DG14-56	Bracket of fan (pair)	1
47	DG13-1	Water tank	1
48	DG11-45	Drier	1
A	DG14-190-SL	Top left hinge	1
B	DG14-212-SL	Lower left hinge	1
C	DG22-3021	Bottom grill	1
D	DG22-3146	Bottom grill	1
E	DG22-3145	Bottom grill bracket	2



WI6128WH

Cable 60cm 2 zone wine cabinet

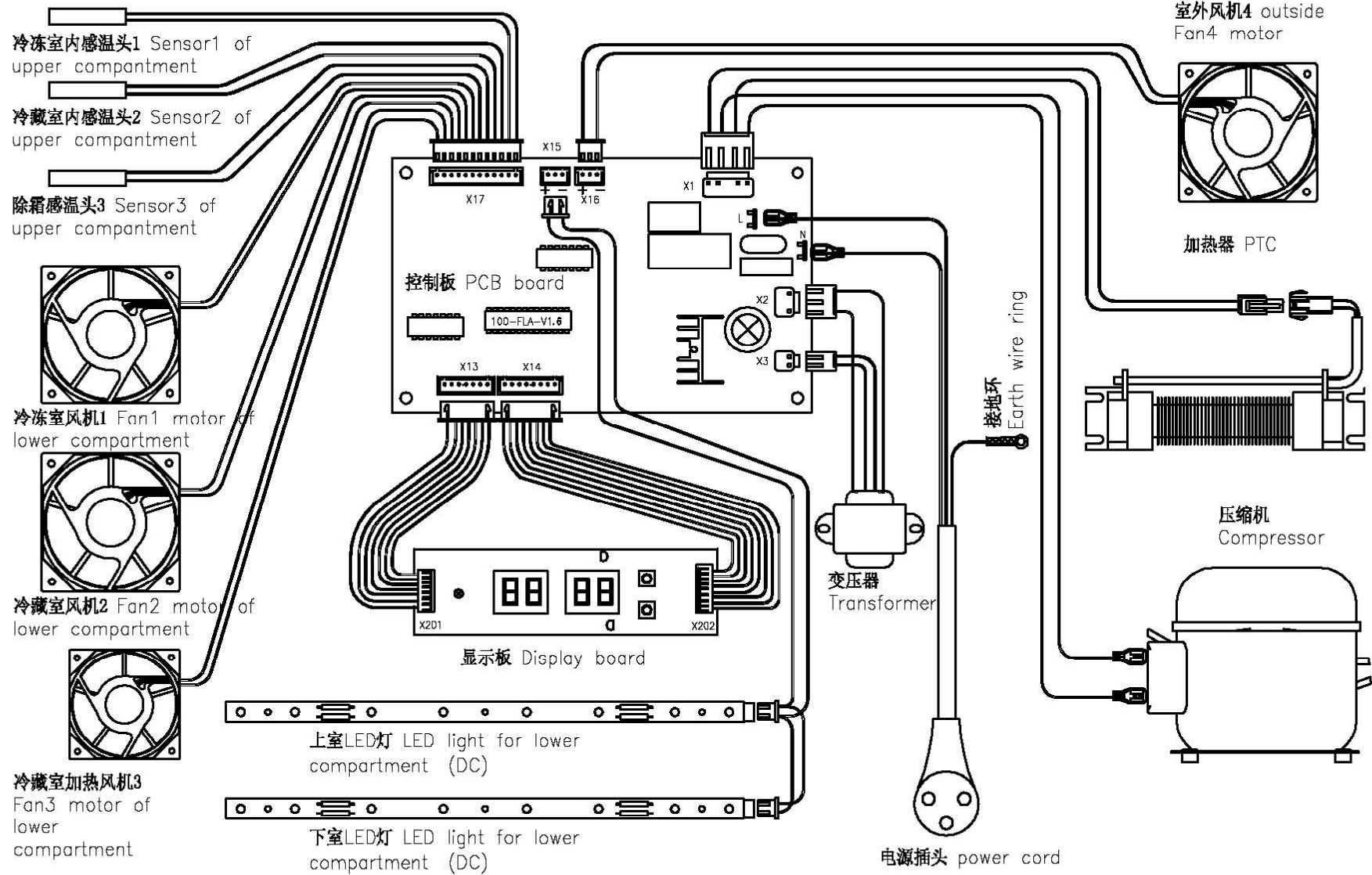



WI6128WH

Caple dual zone wine cabinet

Service Manual

Service Manual

For

JG Series Electronic Dual Temperature Zone Wine Cellar。

JG Series Electronic Dual Temperature Zone Wine Cellar is including Model JG32A , JG45B, JG50B , JG50B-1,JG50FB。

The content below shows different default might happen when the wine cooler is working, and also shows how to find the defaults and repair the defaults. Please find the corresponding default statement and find the repair information in the corresponding pages.

Statement: (Fig.4) shows the correlative diagram Fig.4

(→6) shows the correlative page 6

Warning: before attempting any cleaning or maintenance this unit MUST be disconnected from the electrical supply, to prevent electrical shock

▲ Preparation before maintenance

○ Tools

1. Pliers
2. Phillips head screwdrivers
3. Process pipe
4. Electrical Multi meter
5. Amp meter (5A) (caliper cable type)
6. Electrical soldering iron
7. Wire strippers
8. Seal pliers
- 9/ Scissors

○ Equipment

1. Vacuum pump
- 2.Soldering iron for copper pipes
- 3.Gas meter

▲ Cooling system fault

- How to Evaluate the fault(Page 3)
- How to repair the fault(Page 3)
- How to remove the air duct board (Page 4)
- Diagram showing the front side soldered joints(Page 11)
- Diagram showing the rear side soldered joints(page 11)

▲ Heating system fault

- How to Evaluate the fault(Page 13)
- How to repair the fault(Page 13)

▲ Noise problems

- Compressor noise(Page 13)
- Fan noise(Page 13)
- Refrigerant jet noise(Page 15)
- Capillary vibration noise(Page 15)
- Oil jam noise(Page 15)

▲ Evaporator freezing problems(Page 15)

▲ Unstable internal Temperature(Page 16)

▲ Control system problems

- Fault finding by the self-check mode(Page 16)
- Sensor fault(Page 17)
- How to replace the sensor(Page 17)
- LED display fault(Page 19)
- How to remove parts inside of electrical box(Page 19)
- How to replace the light.....(Page22)
- How to replace the Decorative frame.....(Page23)

- △ Cooling system faults.
- How to diagnose faults:

It should take approximate 3 hours to reach the lowest setting temperature of 5°C for an empty unit (assuming ambient temp of 32 degrees centigrade and continuous operation). If not, check the compressor, cooling fans, controller, and sensors. If all these are working normally, there is probably a cooling system's fault.

- How to repair the default
- 1. Check the compressor

Turn on the unit and check there is electricity current flowing to the compressor using a caliper type Amp meter, the current should be within 0.6 to 2 Amps. If the readings are not in this range, turn off and cut off the pipes (See Fig.20 showing G) and the seal pliers (See Fig.20 showing E.) from the compressor, then turn the unit on again (**in this case only run the compressor for a few minuets, so as to avoid the compressor absorb moist air**) and recheck the current and if there is pressure at the outlet pipe. If the current reading is still out of range specified above and no pressure from the compressor outlet, replace the whole compressor.

- 2. Check the cooling system pipe work:

Carefully check the cooling system after verifying the compressor is working normally. Then follow the procedure below.

1>. Then cut off process pipe and check the refrigerant. If there is not enough refrigerant, the default of the refrigerant system should be caused by the leaking. If the refrigerant is sufficient., it is probably jamed in the capillary.

2>.If the default is concentrated on the cooling system, the checking procedure is as below.

A. Cut off the vent pipe of the compressor, and infuse 0.8-1MP nitrogen by process pipe, and please put the hand close to the cut kerf of the vent pipe. If there is a little gas leak form the terminal, it means normal, or it is jamed.

B. Make sure the capillary is working normally, when the drainpipe is conncted again, and infuse 0.8-1MP nitrogen then test the leakage if the cooling system of the soldering point with the soap water. Check from the the soldering point around the compressor(Fig.20& Fig.21, Fig.21.1), and if everything is ok, remove the air-duct board and chech the soldering point around evaporator. please see the remove method and the procedure as below (→4).

C. If all the soldering point in B is not leaking, there are two possibility, one is leakage in the inner condenser, another is the damage on the parts (such as evaporator,condenser and so on) in the cooling system. If it is the inner damage, it can not be repaired, and if the damage on the parts, replace them.

3>. Make sure that there is not leakage in the cooling system, refill the refrigerant.

- 3. Refill the refrigerant:

1>. Using the vacuum pump form a vacuum in the system, via the joint of the low-pressure process pipe on the compressor , the high-pressure pipeline is on the process pipe of the filter. Apply the vacuum pump for approximately 20 minutes. Until the vacuum is lower than 100Pa. Then solder the compressor process pipe of the filter. Keep the vacuum running while soldering this joint

2>.Fill Cooling system with refrigerant via the process pipe. (The refrigerant is R134a. Regarding refrigerant quantity Please refer to the instruction at back label of wine cellar). Then solder the compressor process pipe after the system is charged with refrigerant.

- 4. Running test:

Replace all the components after the procedures above and turn the unit on. To verify the effectiveness of the repair, monitor

the unit the compressor should automatically stop within - 2.5 deg centigrade of the set temperature and start with +2.5 deg centigrade of the set temperature within approx 3 hours (assuming an ambient temperature of 32°C and the unit is empty).

○ How to remove the air duct board.

1.Remove the shelves firstly and there is two method below.

a. Remove the shelves; some models have Phillips head screws to hold other models have no screws (Fig.1& Fig.1.1)

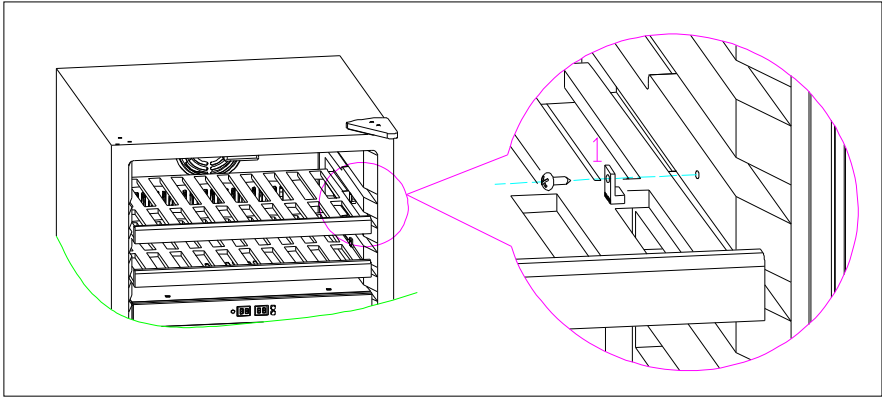

Fig.1

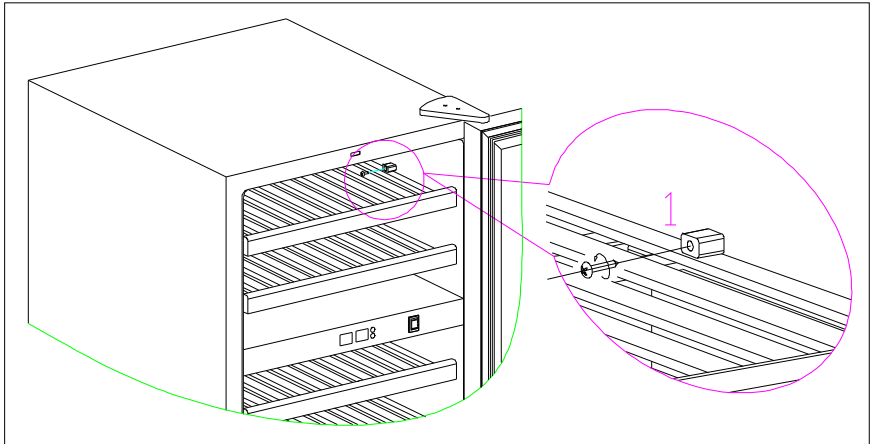

Fig.1.1

b. Some model need to remove the shelves fixer and turn the left shelves fixer 90° anticlockwise, while clockwise the right shelves fixer and remove the fixer according to the arrowhead direction(Fig.2).

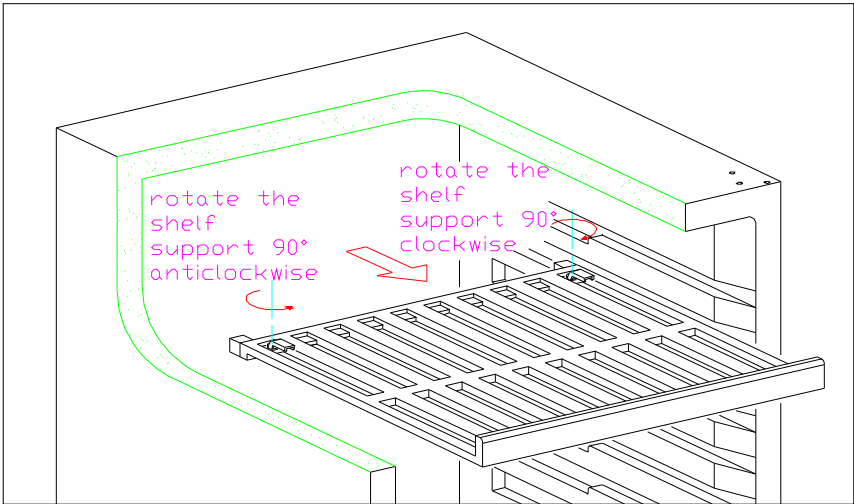

Fig.2

c. Drive up the shelves make it above the fixer 1 (Fig.3), then take it out according to the arrowhead Fdirection(Fig.3.1)

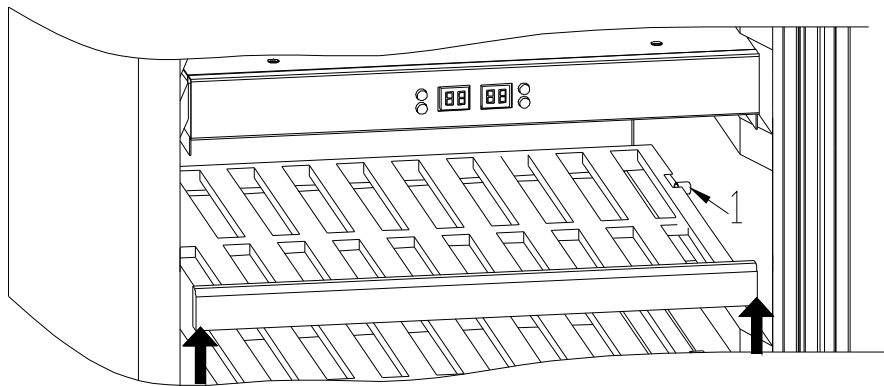

Fig.3

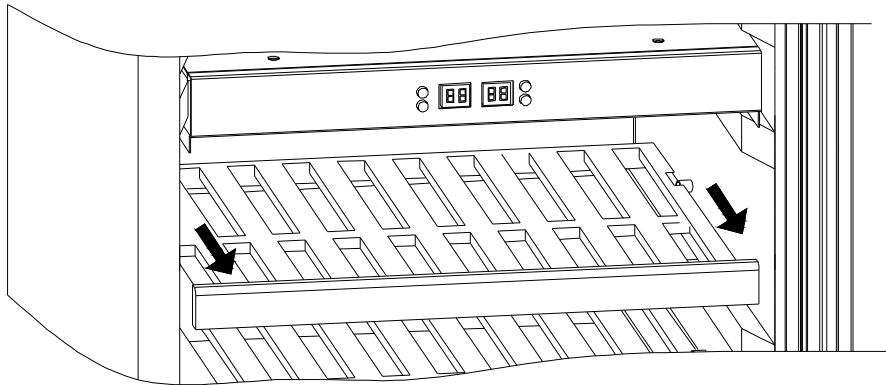

Fig.3.1

d. Pull the shelves to the bottom, circumscribe any side of the right and left, and let the setter of the shelf go out of the channel, and then draw out the shelves. (Fig.4)

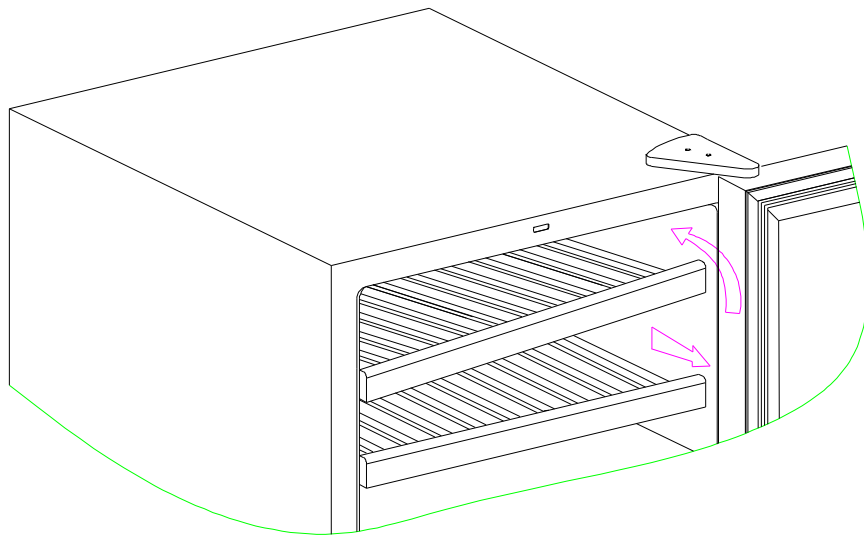

Fig.4

2>How to remove the electrical box.

there are three kind of electrical, old and new and divide version.

①The old structure electrical removement.

a.Remove the shelf, and remove the screw(1,2,3,4) of the middle air-duct cover(Fig.5).
(Please noted: one the below diagram, the diagram on the right side is to describe the spare parts on the PCB board. If there is any similar situation, use the same method.)

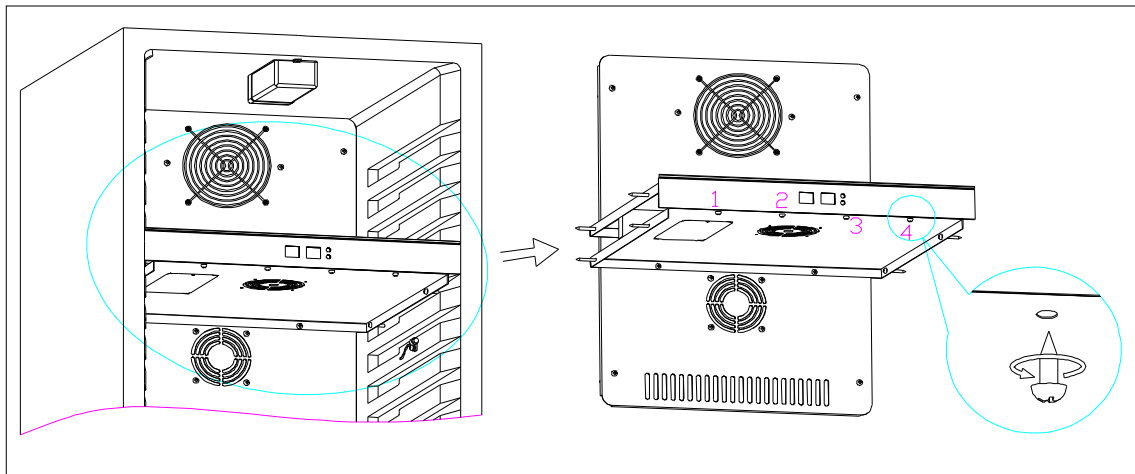

Fig.5

b.Pull out electric box to expose the control panel as per the direction of arrowhead, then unplug all the connectors from the control panel, and remove electric box (A). See (Fig.6)
There are two version of PCB board, as we seldom use the old version, and we do not give any statement, and please see the new version as below (Fig.7)

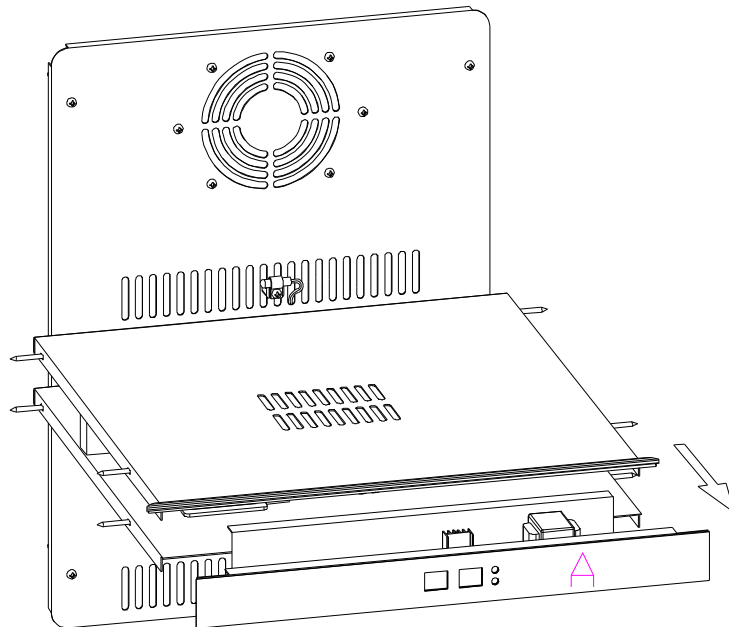

Fig.6

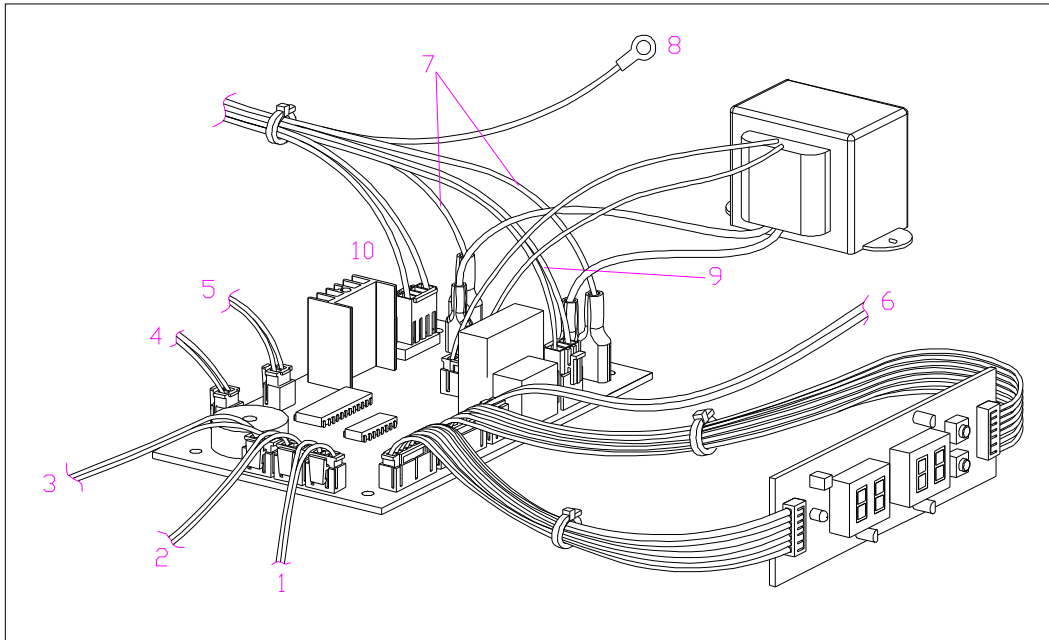

Fig.7

New version control panel connections

1. To the fan of the refrigeration compartment (F3 White).
2. To the air cycling fan.(F2 Yellow)
3. To the fan of the freezing compartment.(F1 red)
4. To the sensor of the freezing compartment (X1 yellow)
5. To the sensor of the refrigeration compartment (X10 White)
6. To the sensor of the evaporator (X11 Red)
7. To the power supply (L,N)
8. To the grounding or earth
9. To the PTC heater (X9 White)
10. To the compressor (X3 White)

c.Remove screws (6,7,8,9,10,11), then remove the lower cover of middle air duct board (F); (Fig.8)

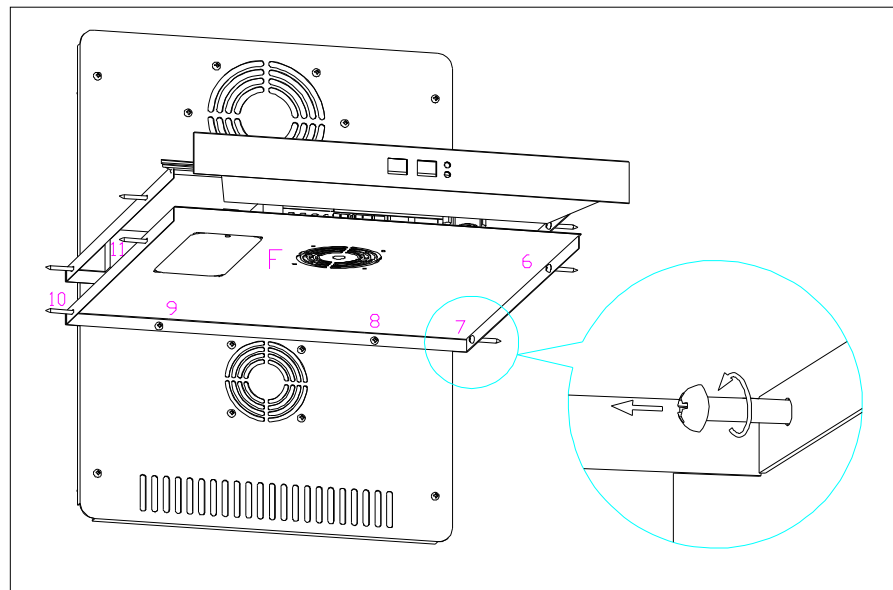

Fig.8

d. Take off the screws of middle air-duct (12, 13, 14, 15, 16, 17), remove the upper cover of the middle air duct board(G), and expose the air-duct cover. (Fig.9)

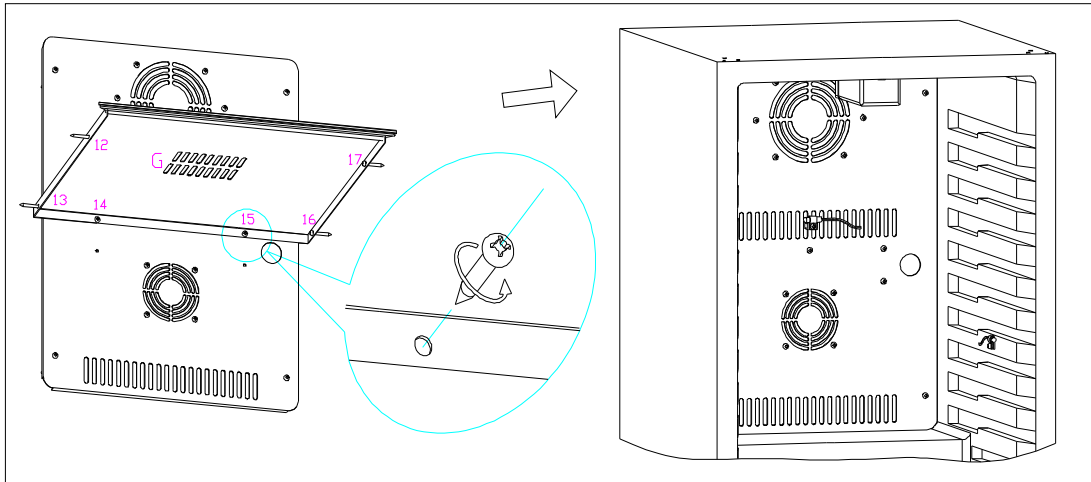

Fig.9

②The new structure electrical removal.

a. Remove the shelves then remove the fixing screws (2,3). (The right diagram shows the box for clarity only,).

See (Fig 10)

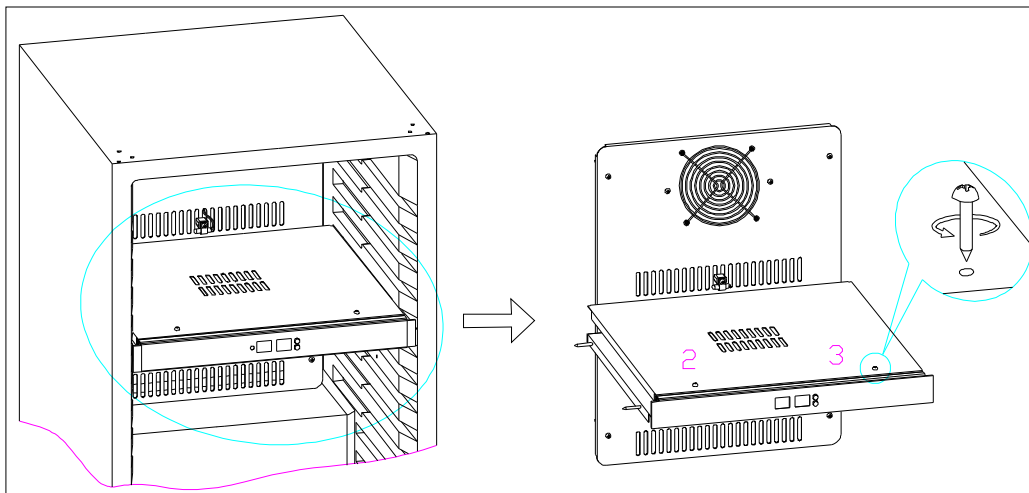

Fig.10

b. Remove the the upper cover of middle air duct board(A) ,then unplug all connectors from the control panel:(Fig.11). The connections of the control boards are as per(Fig.7).

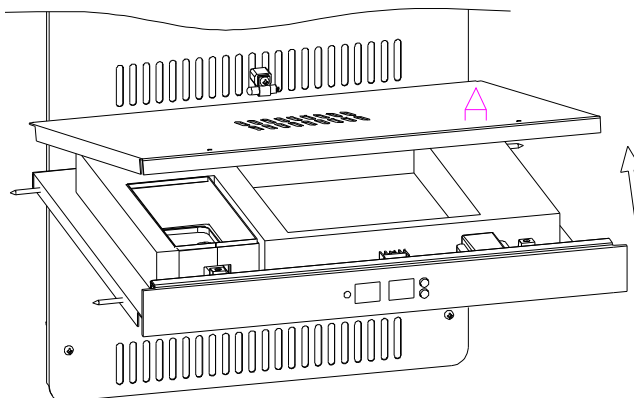

Fig.11

c. Remove the fixing screws (7,8,9,10,11,12), then pull out electric box (C) to expose the air duct board; (Fig.12)

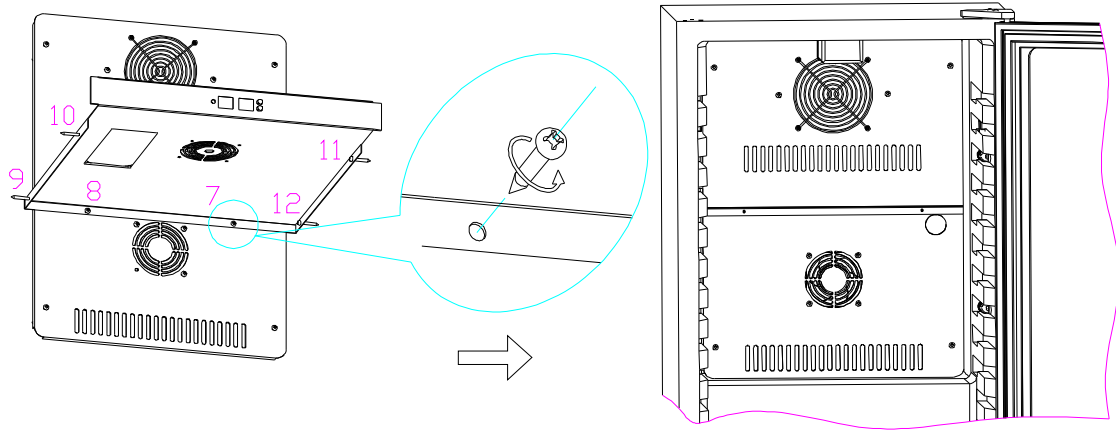

Fig.12

③The divide structure electrical removal.(in this version PCB board is divide into 2 blocks, one is power PCB,the other is control PCB,

a. Remove the shelves then remove the fixing screws (1,2,3,4) (Fig.13)

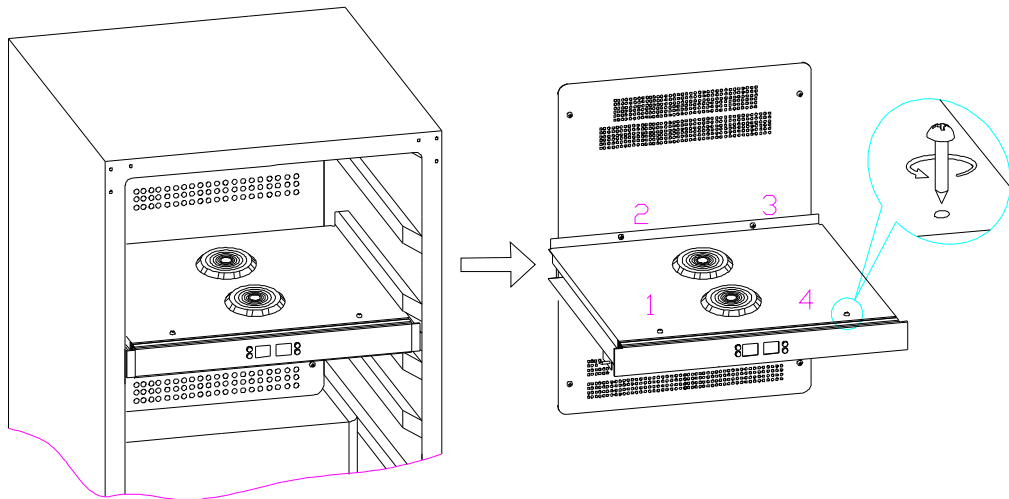

Fig.13

b. Remove the the upper cover of middle air duct board(A)(Fig.14) ;then unplug all connectors from the control panel, The connections of the control boards are as per(Fig.15).

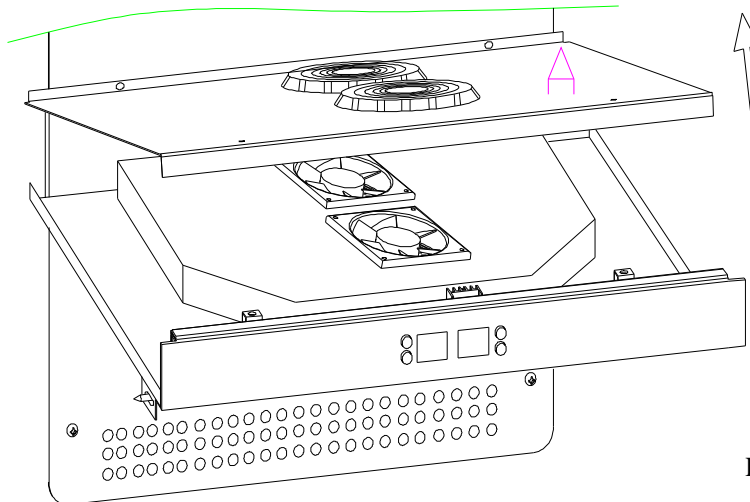

Fig.14

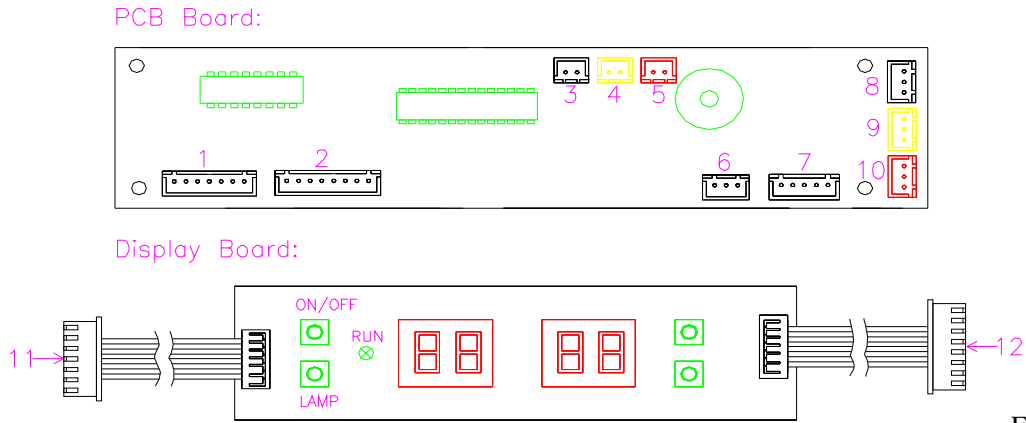

Fig.15

- | | |
|--|--|
| 1. To the display PCB (connect to 11) | 2.To the display PCB (connect to 12) |
| 3. To the sensor of the evaporator (White) | 4. To the sensor of the refrigeration compartment(Yellow) |
| 5. To the sensor of the freezing comparmen(Red) | 6.To LED light (Black) |
| 7.To power PCB (White) | 8.To fan of heater (White) |
| 9.To the fan of the refrigeration compartment(Yellow) | 10.To the fan of the freezing compartment(Red) |

c. Remove the fixing screws (5,6), then pull out electric box (C) to expose the air duct board; (Fig.16)

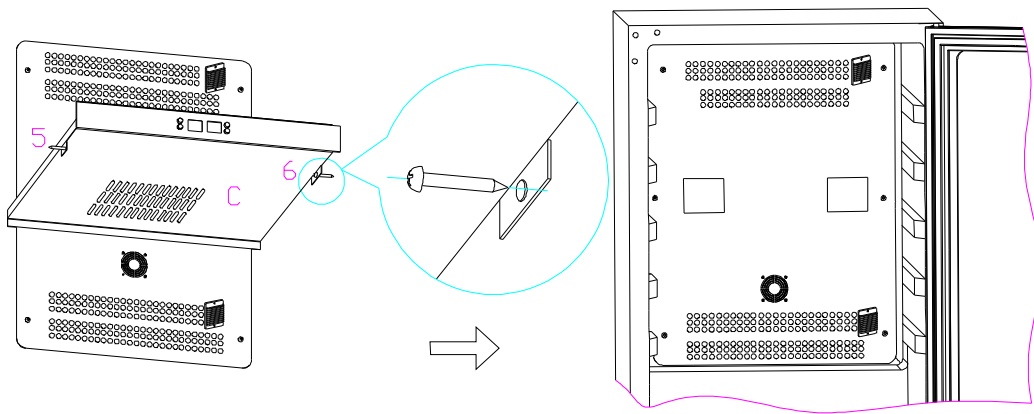

Fig.16

3>. How to remove the air duct board(A),There are two kind of air duct board(A)

a.Remove the fixing screws of air duct board (1,2,3,4,5,6), then pull out air duct board (A). See (Fig 17)

Be attention to unplug the connection wire when removing the air-duct board. You can move slowly aside until you can see the fans wire, and unplug it, and then take out the whole air-duct board. ;

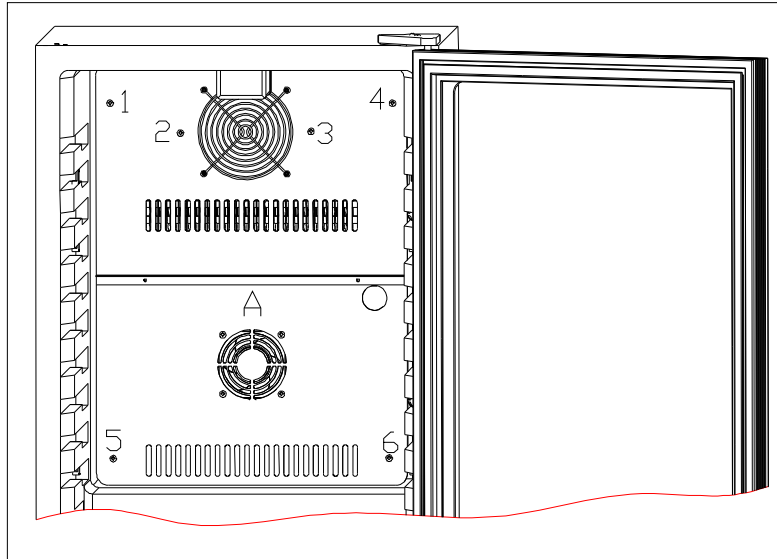

Fig.17

b.Remove the fixing screws of air duct board (1,2,3,4,5,6), then pull out air duct board (A). See (Fig 18)

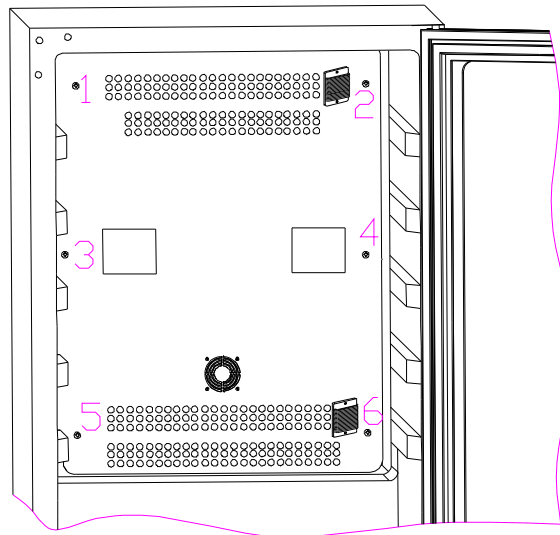

Fig.18

4>. For a View of the internal configuration after removal of the air duct board, see (Fig.1

○ Front side joints location. See (Fig.19)

A. Capillary soldered joints

B. evaporator soldered joints

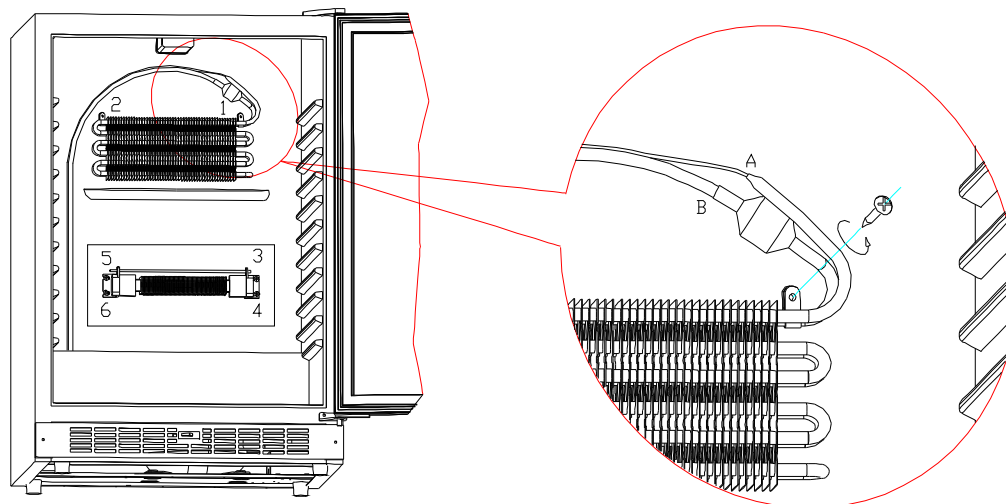

Fig.19

○ Rear side view of the joints position(there are two types condensers inner style(Fig.20) and outer style(Fig.21 & Fig.21.1)).

- B. Dry filter process pipe soldered joint
- C. Dry filter soldered joint.
- D. Capillary soldered joint
- E. Process pipe soldered joint.
- F. Suction pipe soldered joint
- G. Discharge pipe soldered joint
- H. Condenser soldered joint
- I. Anti-Dew pipe soldered joint

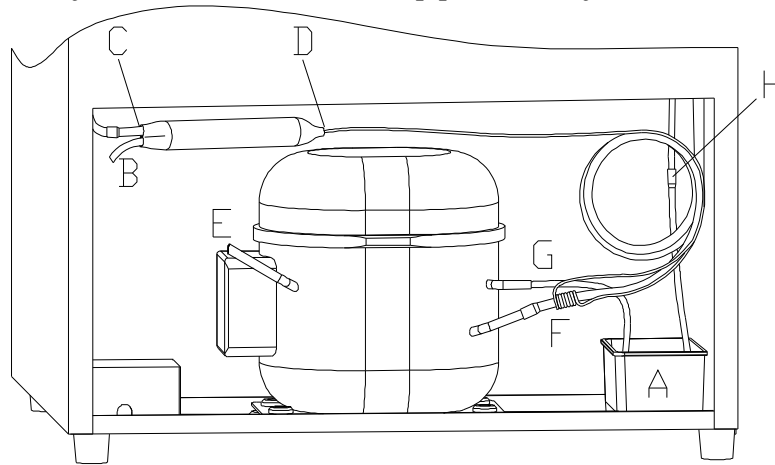

Fig.20

Inner Condenser

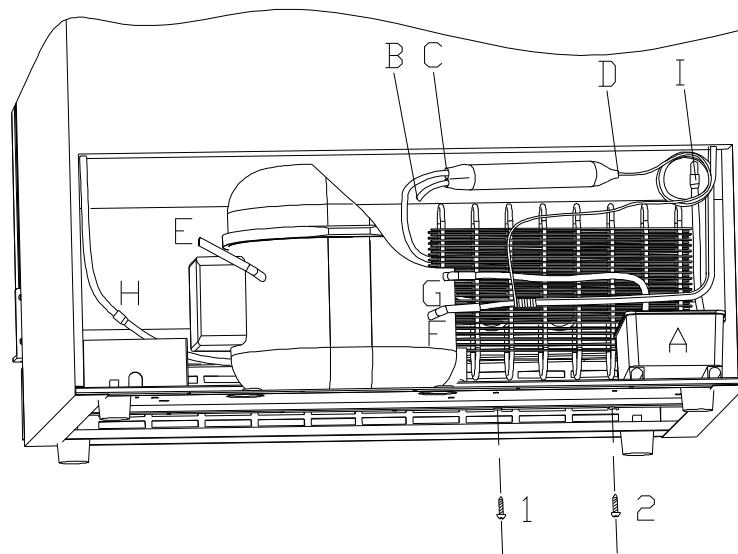
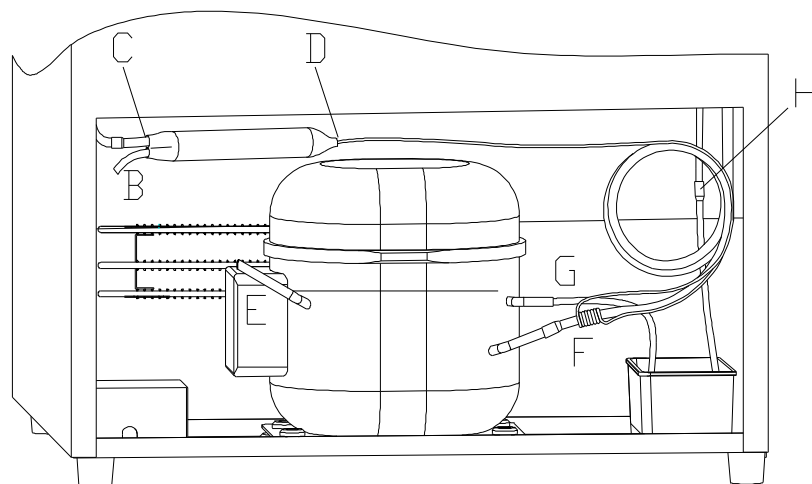

Fig.21



Outer condenser

Fig.21.1

▲ Heating system faults

○ How to diagnose faults:

If the temperature of refrigeration compartment is (-2°C) lower than setting temperature for an empty unit (assuming ambient temp of over 0 degrees centigrade and continuous operation and normal temperature of the freezing compartment), check the heater fan and PTC heater. If both are working normally, there is probably a heating system fault.

○ How to repair the fault:

1. How to check the heater fan.

If the temperature of refrigeration compartment is lower than set temperature but heater fan does not function, after verifying no bad connections replace the fan unit .(Fig.22& Fig.22.1)

2. How to check the PTC heater

Check the resistance at both sides of PTC heater using a Multi meter; the reading should be approx 1.5 K Ω (assuming normal temperature), if open circuits Replace the PTC heater having once verified the connections to the PTC heater. Remove the fixing screws of heater (3,4,5,6) , replace new one.See (Fig.19).

3. If no fault in the fan or PTC heater, replace the control panel, see (Page 20-23).

▲ High noise of wine cellar

○ compressor noise

1. The working of motor and piston motion will cause noise when compressor working. So if noise is steady and not exceeds 42 dB, it's normal. If noise is not steady or very high, it's compressor fault and it should be repaired or replaced.

2. If compressor's shock absorption rubber is hardening or damaged, or fixing screw of compressor is too tight or loose, it will cause noise. The settlement is to change new shock absorption rubber or adjust fixing screws.

○ fan noise

1. When the fans are running , the vanes are circumrotating rapidly and the air flows, which will cause steady and standard noise. The noise should not exceed 32dB and it is normal.

2. If the noise is extremely high and abnormal, the cause maybe as below

a. The axis of the fan is broken

b. The fan is broken and lost balance

3>. How to replace the fans

The fan ruined and we could replace it with the same model's fan

a.. How to replace with the evaporator fan and heater fan

1). Remove the shelves. See (Fig.1、 Fig.1.1、 Fig.2、 Fig.3、 Fig.3.1、 Fig.4)

2). Remove the electric box. See (Page6)

3). Remove the air duct board. See (Fig.17 &Fig.18)

4). Remove screws (1,2,3,4), then replace the evaporator fan. See (Fig.22)

Remove screws (5, 6, 7, 8), then replace the heater fan. See (Fig.22& Fig.22.1)

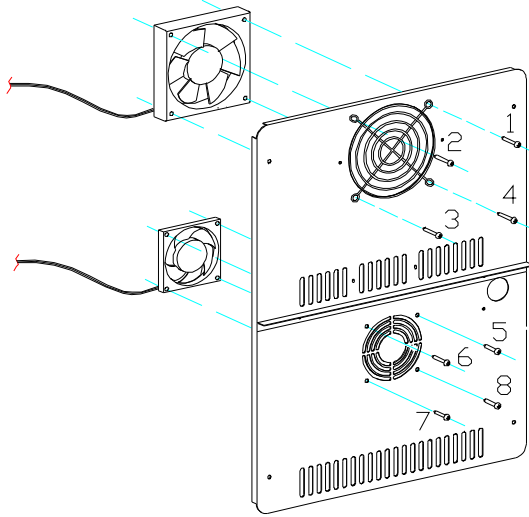

Fig.22

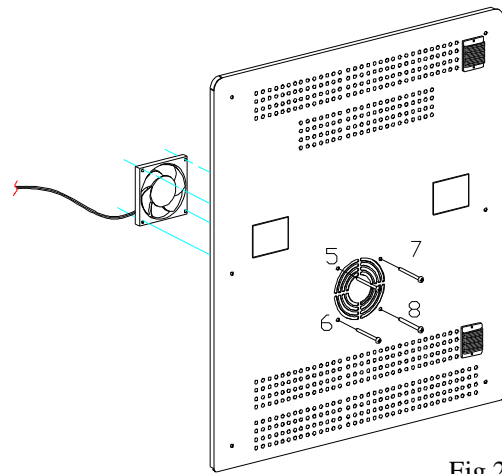

Fig.22.1

b.How to replace air circulating fan

1). Remove the shelf

2). Regarding the new structure electrical box, only remove the up cover of middle upper air-duct board(Fig.10), and remove the screw(1, 2, 3, 4), and remove the air cycling fan and replace with a new one(Fig.23).

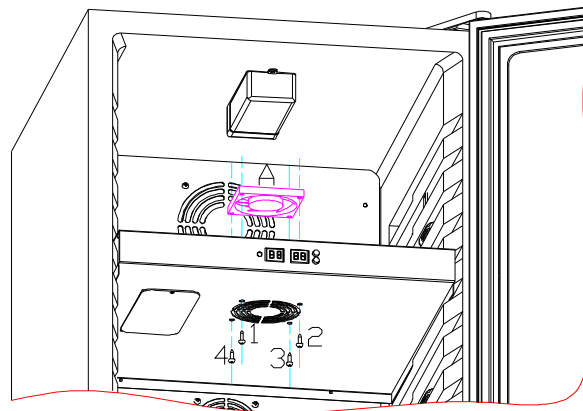

Fig.23

3>, Regarding the old version electrical box, remove middle air-duct board lower cover(Fig.9), and remove the screw (1, 2, 3, 4), replace the air circulating fan (A) . (Fig.24)

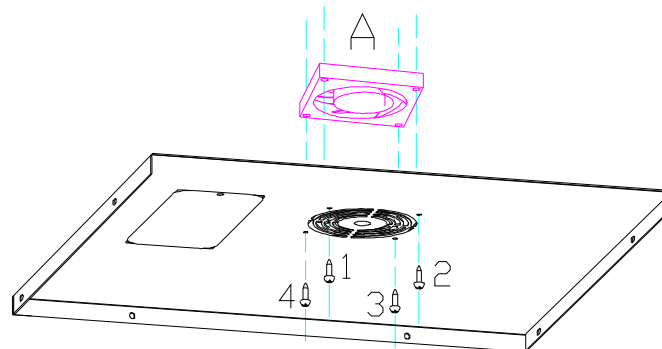

Fig.24

4>, Regarding divide version,taking the up cover cover of the middle air duct board(Fig.13),then take the fan (A、 B) up-ward as the arrowhead direction,and replace it. (Fig.25)

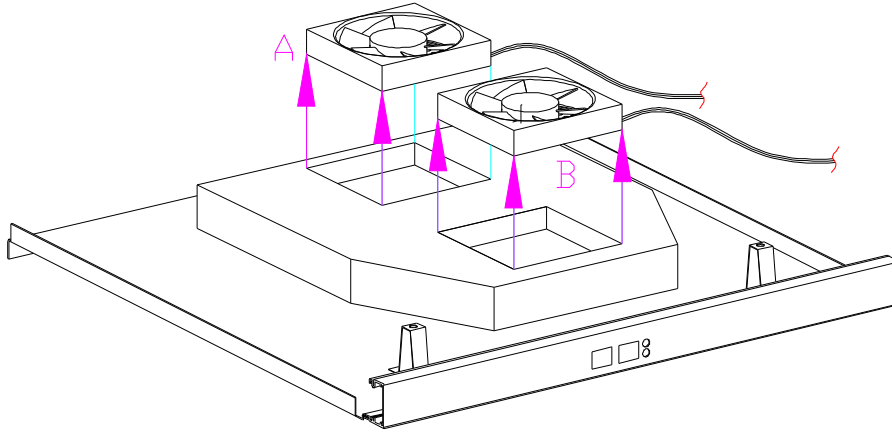

Fig.25

c. How to replace the the condenser fan(noted: there are different structure and the fan installing position, but almost the same installation methods).

Please see as below.

- 1>. Remove the spring (A) , and remove the compressor electrical cover (B) (Fig.26).
- 2>. Remove the two terminal of the fan electrical code(C, D) , mark them before removal to avoid mistake(noted: the diagram below take ZEL compressor as a sample). In fact, different manufacturer's compressor connection is different, and mark it before unplugging the connection. (Fig.26).
- 3). Remove the two screw (1, 2) of the fans with the Phillips head screwdrivers, and remove the condenser fan(in different model the fan installing position are different,but the replace methods almost same). (Fig.26)
- 4) Remove the 4 fixing screw of the fans with the Phillips head screwdrivers (3, 4, 5, 6) , replace the fan(Fig.26.1).

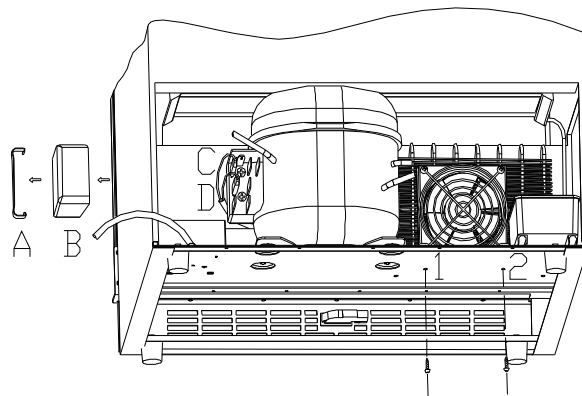

Fig.26

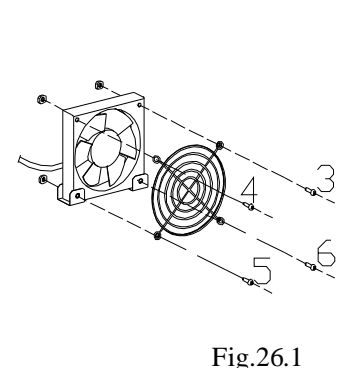

Fig.26.1

○ Refrigerant jet noise

Default: If here is intermittent noise like a water spray from the capillary.

Reason: The end of the capillary in the evaporator is in the wrong position, or there are rough edges on the end of the capillary

Resolvent:

- 1>. Heat the soldered joint of the capillary ("A" of Fig.19), then remove the capillary from the evaporator and smooth the end with an eraser. (Caution: do not allow any particles into capillary unit)
- 2>. Replace the capillary into the evaporator, then solder it back into the correct position (not exceeding 15mm in the evaporator) and pack the joint with anti vibration compound
- 3>. Recharge with refrigerant. See (Page3)

○ Capillary vibration noise

Default: high frequency impact noise in capillary Zone.

Caused by either:

- 1>. The capillary being insert too deep into the evaporator, so when the refrigerant is Jetting, the end of vibrating capillary will hit the inside of the evaporator.
- 2>. Vibration from the capillary touching the inside of the cabinet or air duct board, then when refrigerant is jetting.

Solutions:

- 1>. If the capillary is inserted too deep, heat it with the solder, solder it again(Please noted, the deep inserted is not bigger than 15mm), and vacuumize it and add the refrigerant. (page 3)
- 2>. If the capillary touch the inner cabinet and the air duct panel, adjust the position of the capillary and add the incabloc plastic. (Fig.19)

○ Oil jammed noise

Fault: intermittent and deep jet noise coming from inside of the capillary.

Caused by: Compressor oil flowing into the cooling system pipe work because of wine cooler lean during transportation, and the jetting oil in the capillary cause noise.

Solutions:

Clean the cooling system pipe, and recharge with refrigerant see (page 3)

▲ Evaporator freezing.

- Because the gasket is not air-proof, or the door is not closed well, cause much water fill in the the cabinet, and the water got frozen when it encounter the cold air, sometimes the ice is too thick, and it will block the fan or broken the fan.

The solution:

- 1>. Replace the door gasket or close the door well. If the door gasket is slightly not air-proof, it can be repaired by the heat dryer.
Aiming at the distortion of the gasket with the heat dryer, and move up and down until it expand to the normal state. When it is cool, check it with the door closed, if there is any distortion, dry it again until it fix for the door. (Fig.27)
- 2 >.If the fan is damed seriously or brocken, replace it with the new fan(Fig.22& Fig.22.1)

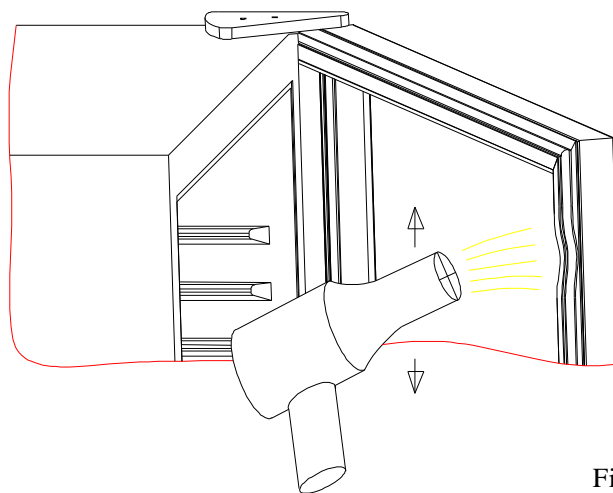

Fig.27

▲ Unstable temperatures inside the cabinet.

The unstable temperature is caused by the evaporator fans cease, and it can be check by the below method: When the compressor is running, the light “Run” is on, the fan should be running, if the fan stop, check the whether is any fault in the fan or fan connection. If the fan is broken, replace it with the fan of the same model. (Fig.22)

▲ PCB system’s default.

○ The differences between the new and old version PCB board.

There are new and old versions of PCB board (Fig.7)in the dual temperature series wine cooler. The differences is the new PCB board add the sensor X11 socket, and exchange the X10 socket in the refrigerator sensor and the X1 socket. If the old PCB board is broken, we should change the electrical box and PCB board.Please refer to the old structure’s dismantlement (Page 4).

○ Fault finding by self-check mode.

This series wine cellar has a computerized controller with built in self-check function. Start the self-check mode as follows:

1>. Press and hold “Set lower” and “Set upper” button with power on. 2 beeps will sound, and then the controller will start the self-check function,

2>. If everything is operating correctly,

- a. No response when pressing buttons.
- b. LED only display 20°C if ambient temperature is over 20°C, and display actual temperature if ambient temperature is lower than 20°C.
- c. The compressor works and the “RUN” indicator light are on all the time.
- d. If the cooler has condenser and evaporator fans they should work at full speed; Heater and air cycling fans should work for 30 seconds alternately.
- e. The switch controls the light functions normally.

3>.If the situation fit for a~e statement, the spear parts are normal, if the various components of the unit do not respond as above, check the faulty part and relevant connection. If replace the part does not cure the fault, replace the control board. see. (→4)

4>. To return the control panel to its normal working mode unplug the unit and plug it in 14 / 18

5>. Only the new version control panel has a self-check mode.

○ Sensor default

1>. The LED temperature display should the actual ambient temperature shortly after the unit is plugged in, if not,take the electrical box apart see (Page 6), check if the sensor plug is connected properly, if the connections are good and the fault persists replace the sensor.

2>. If the LED displays “E1” indicates a freezing compartment sensor open circuit fault and the sensor should be replaced see (Page 18)

3>. If the LED displays “E2” indicates a freezing compartment sensor short circuit fault and the sensor should be replaced see (Page 18).

4>. If the LED displays “E3” indicates an evaporator sensor open circuit fault and the sensor should be replaced see (Page 18).

5>. If the LED displays “E4” indicates an evaporator sensor short circuit fault and the sensor should be replaced see (Page 18).

6>. If the LED displays “E7” indicates a refrigeration compartment sensor open circuit fault

and the sensor should be replaced see (Page 19).

7>. If the LED displays “E8” indicates a refrigeration compartment sensor short circuit fault and the sensor should be replaced see (Page 19).

8>. If the LED displays 37°C, this default only happen in the old model. Because the old machine use the old PCB board. If the sensor is broken, and the temperature will be infinity; as the PCB board is set maximum 99, and when the temperature exceed Fahrenheit 99(37°C). The solution is to find out the default sensor and replace it with the same model's (Fig.18)

○ How to replace sensors

1>. Evaporator sensor (there are two different position a and b of the evaporator sensor)

a. One is that the evaporator sensor is plugged into the fin of evaporator. Remove the air duct board to access the sensor plug (A) and unplug in the direction of the arrowhead. See (Fig.28), then unplug the other end of sensor from the X11 socket of the control panel, and replace it. See (Fig.7).

b.

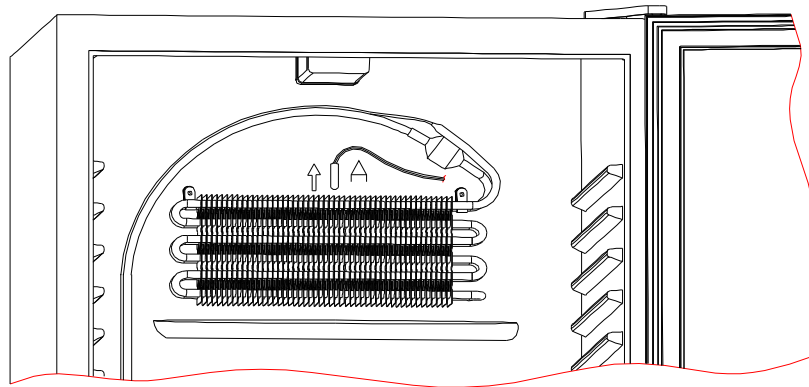

Fig.28

b . The other is that the evaporator sensor is fixed on right side under the evaporator, Remove the air duct board to access the sensor,then remove the sensor in the direction of the arrowhead.replace it.See (Fig.28.1)

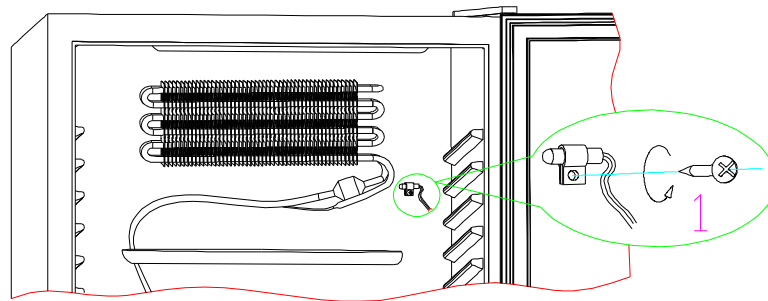

Fig.28.1

2 >. Freezing compartment sensor.

According to the different model, sensor is in the two different position. As the diagram(Fig.29) shows below A, A1.

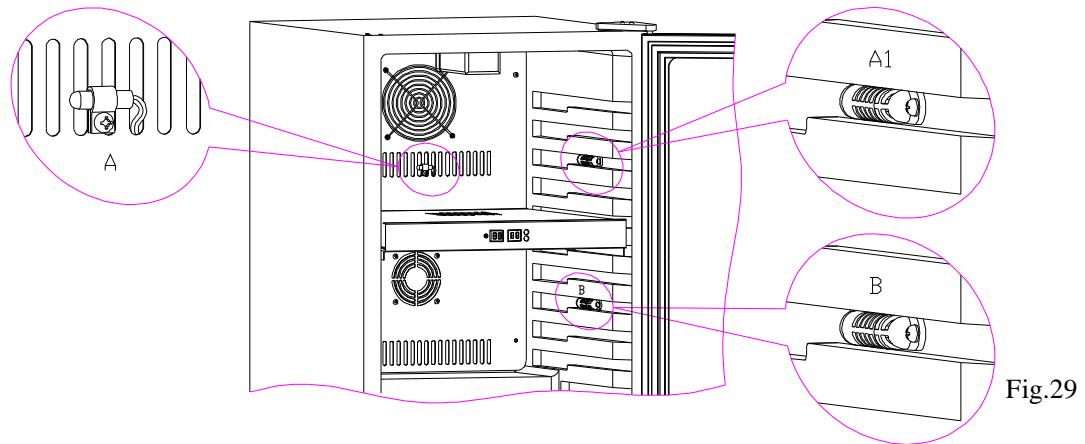

Fig.29

a. As to the sensor in the point A, remove the air-duct board firstly (Page 4), and remove the fixing screw, then take off the sensor, and then unplug another socket X 1 of the sensor in the PCB control panel board in the (Fig.7), and it can be replaced with the same model.

b. As to the sensor in the point A1, there are two installation methods. As the diagram below (Fig.30 & Fig.30.1)

© The new installation version's sensor: remove two fixing screws 1 with the philip head screw driver, and remove the sensor cover 2 and draw the sensor 4 from the sensor cover slightly, and then unplug the Housing 3, it can be replaced with the same model's sensor.

© The old installation version's sensor: remove the air-duct board (page 6), and take off the fixing screw (1), and take off the sensor, and unplug another terminal's from socket X1 (Fig.7) in the PCB board, and replace the sensor with the same model's (Fig.30.1).

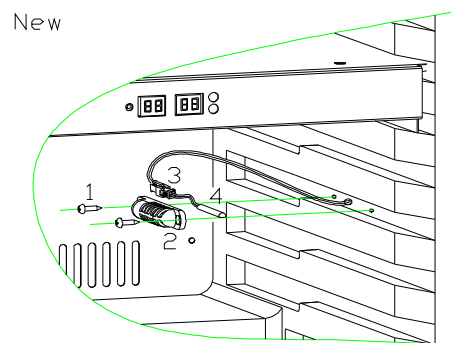

Fig.30

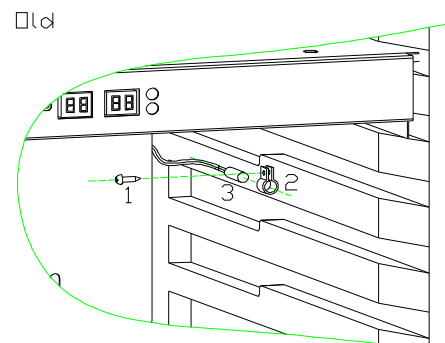

Fig.30.1

3 >. Refrigeration compartment sensor.

Refrigeration compartment sensor is located on (B) of (Fig.29). It has two different installations with 2 different replacements. The replacement is similar with (A1) See (Fig.30 & Fig.30.1)

4 > The solutions above are not good enough, we recommend a better and faster method for you, this method is apply for the below situation.

a. The sensor of the freezing position (A). (Fig.29)

b. The sensor of the refrigerator position, old installation method. (Fig.30.1)

Replacement: (Fig.31)

a. Take off the sensor of the fixing screw, and draw the sensor off, and cut in the end. (A)

b. Tear off the wire 50MM after cutting it off, in the end tear 12mm off. (B)

- c. Prepare two heat compressing pipe.(specification: inner diameter ϕ 2.5mm \times 25mm) prepare a sensor, specification as the diagram (C) (D).
- d. Divide the two heat compressing pipe, and insert them into the wire terminal of the sensor, and connect them spare sensor with the wire, and connect the heat compressing pipe with the middle of the conjunction, dry them until they are tight(E).

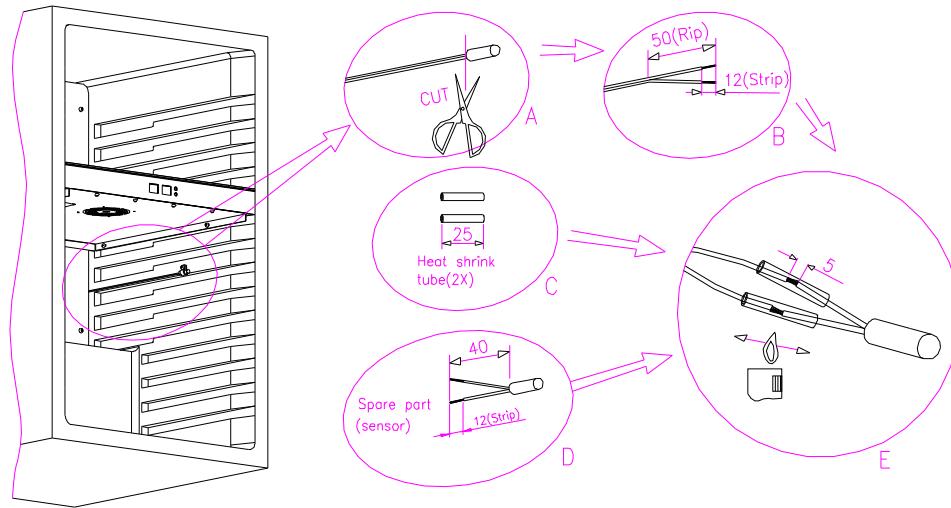

Fig.31

○ The digital display default

This malfunction is caused by the display panel's default, replace with the same model's display panel. (Fig.32 & Fig.33)

○ The dismantlement method of the electrical box spear part.

There are three type of electrical box,old,new and divide version.

PCB board has two modes:

model : PCB board is a complete block,and in the electical box of the same box with the transformer;(Fig.7)

model 2: PCB board divide into 2 blocks, the main PCB board is in the electrical box(Fig.15),the other power PCB board is in the left of the compressor's box with the transformer. (Fig.35)

①The old structure electrical removement.

- a. Remove the shelf, and remove the screw(1,2,3,4) of the middle air-duct cover. Pull out electric box to expose the control panel as per the direction of arrowhead. See (Fig.5 & Fig.6)
- b. Unplug all the connectors from the control panel, and press the 4 studs (5) one by one, and up draw the control panel, and take off the PCB board (B) . Replace it with the same model's PCB board; (Fig.32)
- c. Remove the the screw of the two transformer and take off the transformer (C) for replacement(Fig.32).
- d. To replacing the display board.

Pull the four 4 display cover fasteners on display board cover (E) as per arrowhead direction, and then remove the display board (D) and its two connectors from both sides. Replace the display board. See (Fig.32)

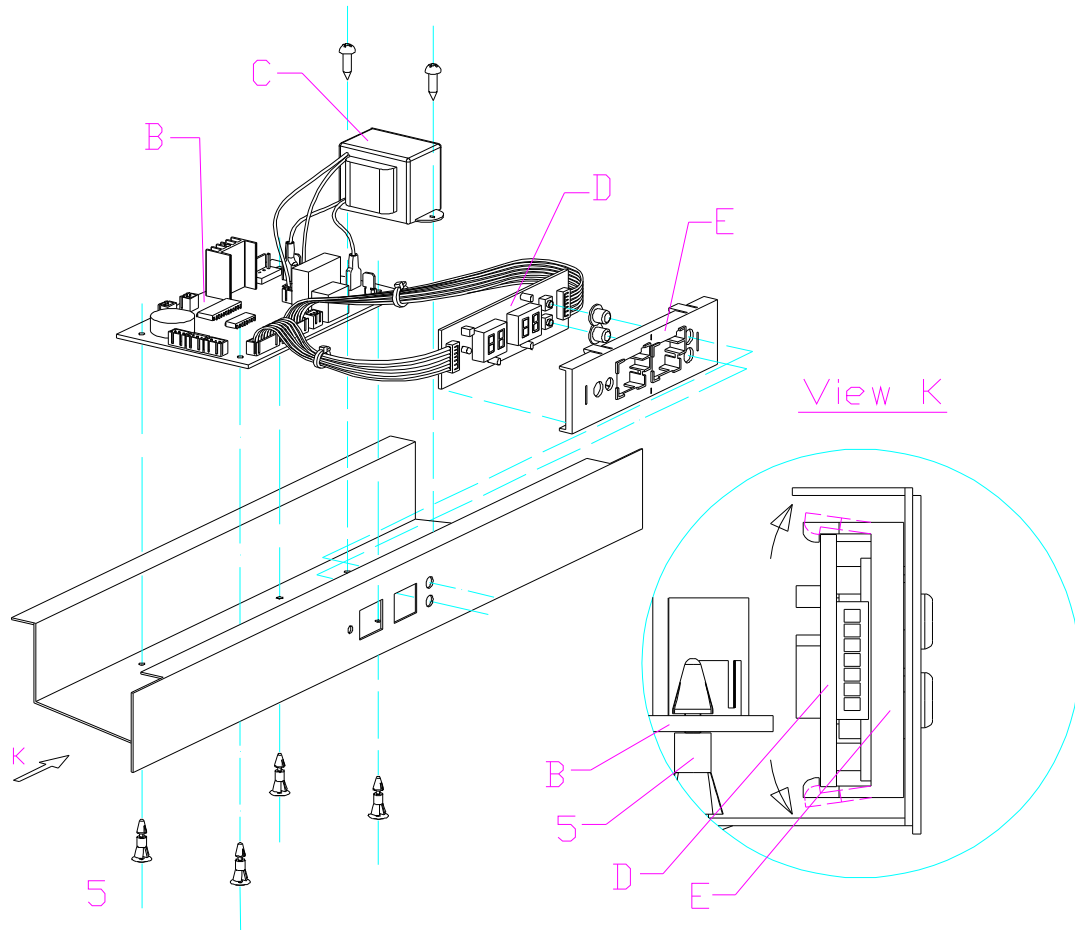

Fig.32

②The new structure electrical removal.

- a. Remove the the shelf , and remove the upper cover of the air-duct panel, expose the whole PCB board(Fig.8)
- b. Unplug all the connector, press the 4 studs (6) one by one. Updraw the PCB board, and draw off the PCB board(C), , replace it with the same model's PCB board. (Fig.33)
- c. Remove two fixing screw of the transformer, take off the tranformer (D) for replacement. (Fig.33)
- d. How to replacing the display board.
Pull the four 4 fasteners of display board cover (F) as per arrowhead direction, and then remove the display board (E) and its two connectors from both sides. Replace the display board. See (Fig.33)

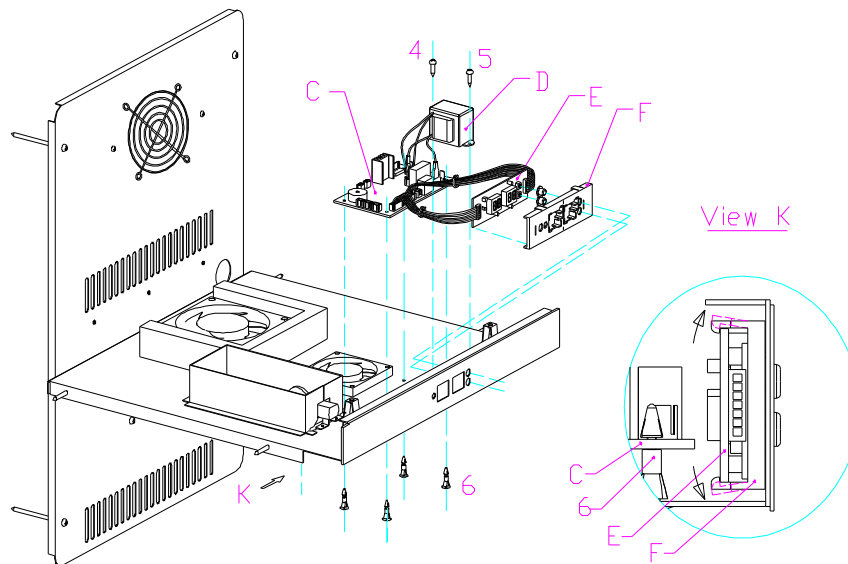

Fig.33

③ The divide structure electrical removal.(in this version PCB board is divide into 2 blocks, one is power PCB,the other is control PCB)

A. How to replace the control PCB

a. Remove the the shelf , and remove the upper cover of the air-duct panel(Fig.13), expose the whole PCB board(Fig.34)

b.Unplug all the connector, press the 4 studs (3) one by one. Updraw the control PCB board, and draw off the PCB board, , replace it with the same model's PCB board. (Fig.34)

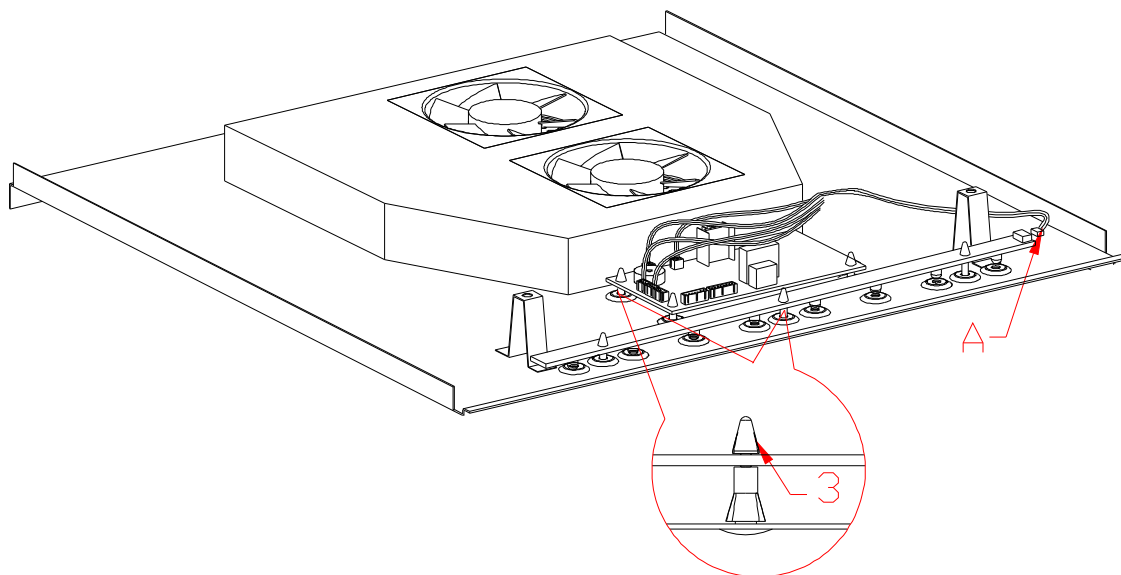

Fig.34

B.How to replace the power PCB and transformer.

a.Remove the two screw(1) that fixing the electrical box for power PCB (Fig.35).

b.Remove the the electrical box(C) for power PCB (Fig.35).

c. Unplug all the connector, press the 4 studs (4) one by one. Updraw the power PCB board(A), and draw off the PCB board, , replace it with the same model's PCB board. (Fig.35) (Vlew K)

d.Remove two fixing screw(3) of the transformer, take off the tranformer (B) for replacement. (Fig.35)

Divide version control panel connections (Fig.36)

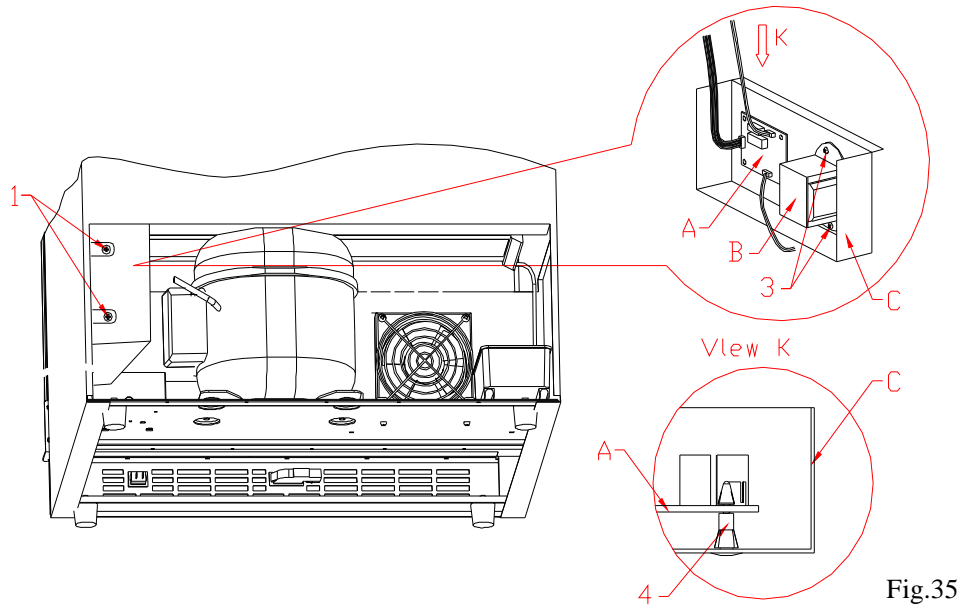

Fig.35

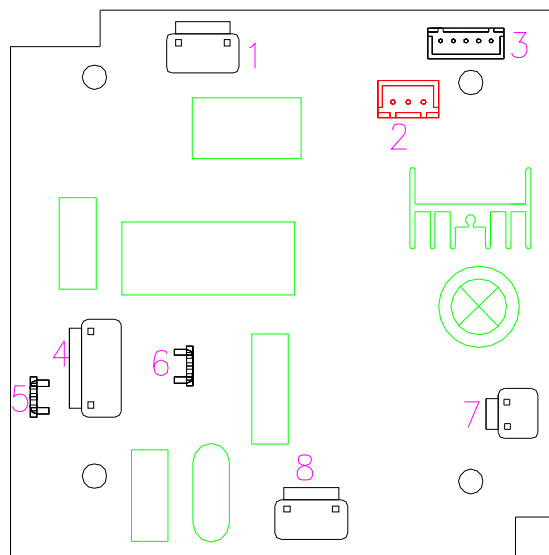

Fig.36

- | | |
|------------------------------------|----------------------------------|
| 1.Heater connector (White) | 2.Outer fan connector (Red) |
| 3.To control PCB (White) | 4. Compressor connector |
| 5.Connectors of the power N | 6. Connector of power L |
| 7. Transformer secondary connector | 8.Transformers primary connector |

○How to replace the light

1 >. How to replace the bulb

- a. Remove the screw fixing lamp cover,take off the lamp cover(Fig.37).
- b. Remove the bulb according to the direction arrowhead show, replace the bulb(Fig.37.1).

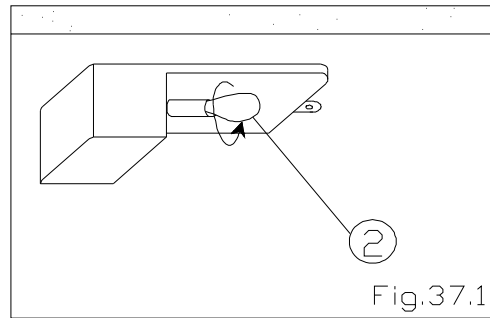
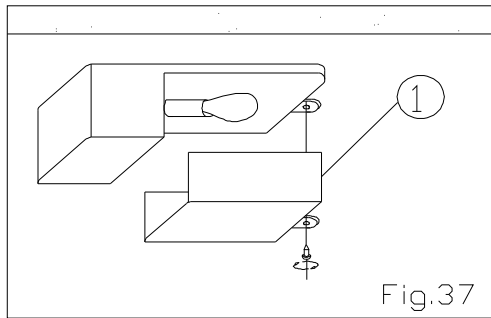

c. Remove the shelves, take the up cover of the middle air duct board, remove the screws(1,2) fixing the lamp hold, remove the bulb according to the direction arrowhead show, replace the bulb. (Fig. 38)

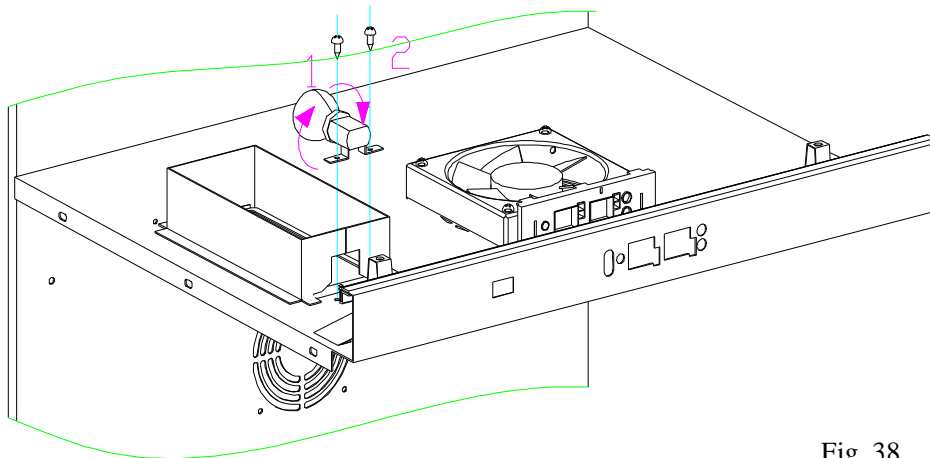

Fig. 38

2 >. How to replace the LED light

A. How to replace the LED light in upper zone (Fig.39)

- a. Remove the shelves. (Fig.1)
- b. Remove the screws(7) fixing light cover(B).
- c. Remove the screw(8) in the center of the light cover, disconnect the LED connector(C) replace the LED light.

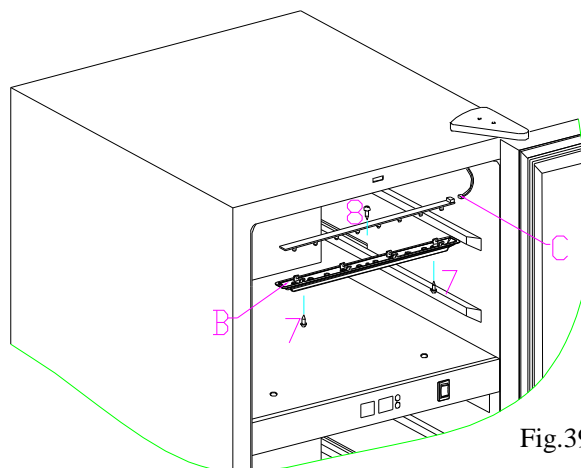

Fig.39

B. How to replace the LED light in lower zone

- ①, Remove the shelves (Fig.1, Fig.1.1, Fig.2, Fig.3, Fig.3.1, Fig.4), take the up cover of the middle air duct board (Fig.13) .

②, Unplug the LED light connector, press the 4 studs one by one,take the LED light upward,replace it.
(Fig.34)

○ How to replace the decorative frame
Remove the screw(1,2,3),pull the decorative frame according to the arrowhead that view K show,then remove the screw(4,5,6) from the gap between decorative frame and cabinet,remove the decorative frame.
(Fig.40)

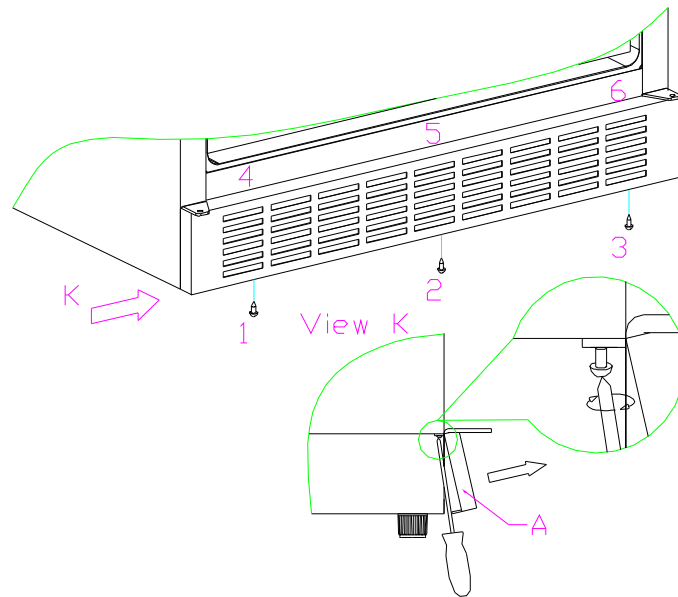

Fig.40