



# WF1546

Caple Free Standing wine cabinet



Technical information

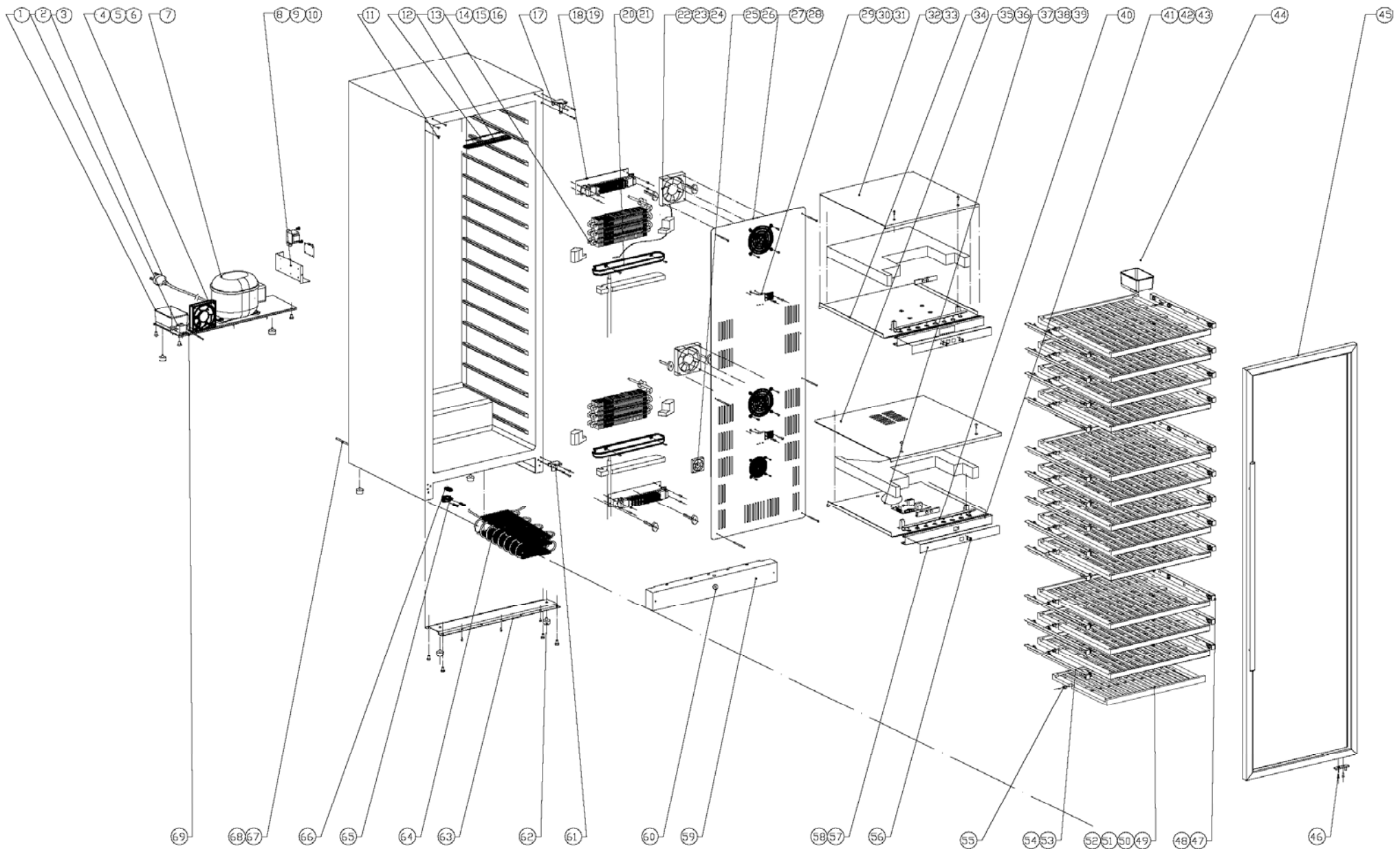

**WF1546**

Caple Free Standing wine cabinet



## WF1546 - Caple Freestanding Wine cabinet

Item	Part Code	Description	Qty
1	DG13-1	Water tank	1
2	DG12-37.1	Refrigerant valve	1
3	DG2-14	Power cord	1
4	DG17-145-2	Condenser fan	1
4.	DG7-3.2-BH	Condenser fan	1
5	DG19-3	Fan cover	1
6	DG14-56	Fan bracket	2
7	DG1-88	Compressor	1
8	DG22-302	Electrical box cover	1
9	DG3-94-1	PCB board	1
10	DG6-19	Transformer	1
10.	BZ5-120	Transformer label	1
11	DG13-8	Decorative nail	4
12	DG3-14-W	LED light	1
13	DG13-129	lamp-chimney	1
14	DG12-50	Evaporator	1
15	DG12-59	Evaporator	1
16	DG18-63	Foam	4
17	DG14-160-SR	Top right hinge module	1
18	DG11-1	Heater	2
19	DG14-24	heat insulation panel	2
20	DG13-10	Water box	2
21	DG18-59	Foam	2
22	DG7-3.2-BH	Fan	1
22.	DG17-143	Fan wire	1
23	DG7-3.2-BH	Fan	1
23.	DG17-144-1	Fan wire	1
24	DG19-6	Fan cover	2
25	DG7-41-BH	Fan	1
25.	DG17-144-1	Fan wire	1
26	DG19-2	fan cover	1
27	DG22-375	Air duct board	1
28	DG13-193	Support bracket of middle aire duct board	2
29	DG8-20	Senser	1
30	DG8-21	Senser	1
31	DG8-26	Senser	1
32	DG22-234	Air duct board	1
33	DG18-60	foam	1
34	DG22-233	Air duct board	1
35	DG22-376	Air duct board	1
36	DG18-83	foam	1
37	DG22-377	Air duct board E	1
38	DG7-3.2-BH	Fan	1
38.	D17-145-1	Fan wire	1



## WF1546 - Caple Freestanding Wine cabinet

Item	Part Code	Description	Qty
39	DG19-6	fan cover	1
40	DG3-18-W	LED light	2
41	DG13-32-1	Display board fix	1
42	DG13-327	Display board fix	1
43	DG13-194	Display board fix	2
44	DG13-1.1	Humid box	3
45	DG23-204	Door	1
45.	DG13-3034	ornament	1
46	DG14-169-SR	Door axis	1
47	DG13-253-R	Track Right	6
48	DG13-253-1R	Track Right	2
49	DG15-155	Wooden shelves E1	6
49.	DG15-138	Stainless Steel Trim	6
50	DG15-1002.2	Wooden shelves WE-2	1
50.	DG15-106	Stainless Steel Trim	1
51	DG15-156	Two-double Wooden shelves	2
51.	DG15-138	Stainless Steel Trim	2
52	DG13-274	Wooden shelf sliding plate	16
53	DG13-253-L	Track Left	6
54	DG13-253-1L	Track Left	2
55	DG13-7	Shelf stopper	18
56	DG13-130-S	button	6
57	DG20-281	Display panel 1	1
58	DG20-281-1	Display panel 2	2
59	DG22-3103-S	Bottom grill	1
60	DG14-140	Lock	1
61	DG14-170-SR	Lower hinge module right	1
62	DG13-6-16	Cabinet leg, type BC50	4
63	DG22-240	Support bracket of front legs	1
64	DG12-91-1	Condenser	1
65	DG14-170-SL	Lower hinge module left	1
66	DG13-366-B	Door support	1
67	DG12-110-1	Air-circulating pipe (LOWER)	1
68	DG12-110	Air-circulating pipe (UPPER)	1
69	DG22-239	Compressor bracket	1
	M160-057	Door Seal	1



# WF1546

Cable Free Standing wine cabinet

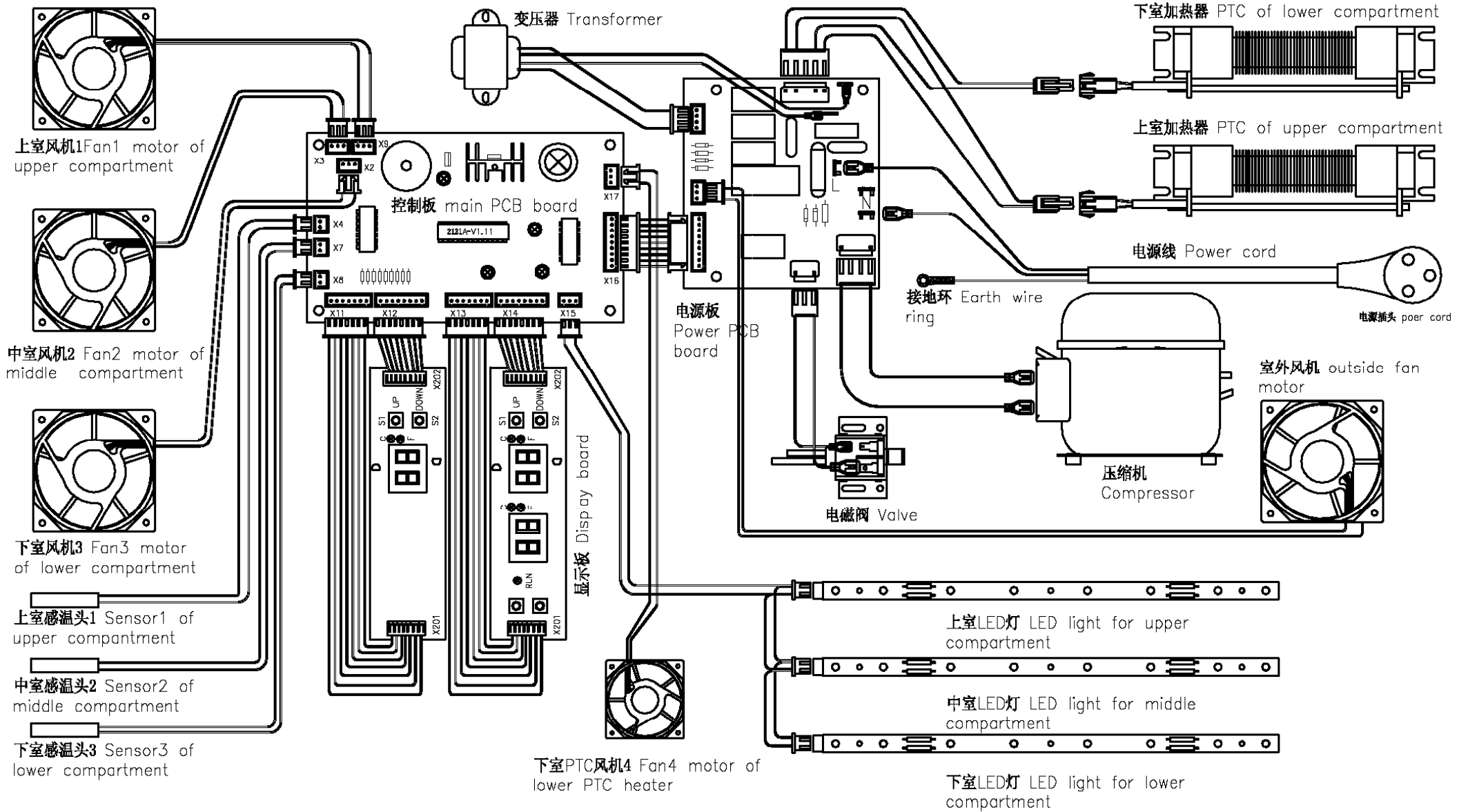

# SERVICE MANUAL

Three temperature zone control wine cooler

WF1546 WF1547

The content below shows different default might happen when the wine cooler is working, and also shows how to find the defaults and repair the defaults. Please find the corresponding default statement and find the repair information in the corresponding pages.

---

Statement: (Fig.4 ) shows the correlative diagram Fig.4

( →6 ) shows the correlative page 6

**WARNING: Before attempting any cleaning or maintenance this unit Must be disconnected from the electrical supply, to prevent electrical shock.**

---

▲ Preparation before maintenance

○ Tools

1. Pliers
2. Phillips head screwdrivers
3. Process pipe
4. Electrical Multi meter
5. Amp meter (5A) (caliper cable type)
6. Electrical soldering iron
7. Wire strippers
8. Seal pliers
- 9/ Scissors

○ Equipment

1. Vacuum pump
- 2.Soldering iron for copper pipes
- 3.Gas meter

▲ Cooling system fault

- How to Evaluate the fault .....(Page 3)
- How to repair the fault ....(Page 3)
- How to remove the air duct board ..... (Page 4)
- Diagram showing the front side soldered joints .....(Page 6)
- Diagram showing the rear side soldered joints .....(page 7)

- ▲ Noise problems
  - Compressor noise .....(Page 8)
  - Fan noise .....(Page 8)
  - Refrigerant jet noise ..... (Page 9)
  - Capillary vibration noise ..... (Page 9)
  - Oil jam noise .....(Page 9)
  
- ▲ Evaporator freezing problems.....(→10)
  
- ▲ Unstable internal temperature problems.....(→11)
  
- ▲ Control system problems
  - Fault finding by the self-check mode .....(Page 11)
  - Sensor fault .....(Page 12)
  - How to replace the sensor .....(Page 13)
  - LED display fault .....(Page 14)
  - How to remove parts inside of electrical box ..... (Page 14)
  - How to replace the light..... (Page16)
  - How to replace the Decorative frame..... (Page17)
  
- ▲ Heating system fault
  - How to Evaluate the fault .....(Page 13)
  - How to repair the fault .....(Page 13)
  
- △ Cooling system faults.
  - How to diagnose faults:

It should take approximate 3 hours to reach the lowest setting temperature of 5°C for an empty unit (assuming ambient temp of 32 degrees centigrade and continuous operation). If not, check the compressor, cooling fans, controller, and sensors. If all these are working normally, there is probably a cooling system's fault.

○ How to repair the default

## 1. Check the compressor

Turn on the unit and check there is electricity current flowing to the compressor using a caliper type Amp meter, the current should be within 0.6 to 2 Amps. If the readings are not in this range, turn off and cut off the pipes (See Fig.4 showing D) and the process pipe (See Fig.4 showing A.) from the compressor, then turn the unit on again (**in this case only run the compressor for a few minuets, so as to avoid the compressor absorb moist air**) and recheck the current and if there is pressure at the outlet pipe. If the current reading is still out of range specified above and no pressure from the compressor outlet, replace the whole compressor.

## 2 . Check the cooling system

1>.Carefully check the cooling system after verifying the compressor is working normally when no zone cooling.It will be refrigerantor leakage, follow the procedure below.

a.Cut off the process pipe and discharge pipe.infill 0.8—1Mpa nitrogen by process pipe.Put you hand near to the discharge pipe and the back of the hand face to the discharge pipe cut kerf. If there is a little gas leak from the terminal, it means normal, or capillary is jamed.(notice:there are two capillary in this unit,normally only one capillary with gas flow,if no any gas leak from discharge pipe, it means one capillary is jamed. Please switch the valve and try again to see if the other capillary is jamed.Refer to 'chack the valve' to switch the valve).

b.Infill 0.8-1MPa nitrogen,and check the welding point point around the compressor (→5) (Fig.4 ) with soap water.If there isn't any leakage,please take apart the airduct board(→3、 →4) (Fig.2.1 & Fig.2.2 & Fig.2.3 & Fig.3) and check the welding point aroudn the evaporator(→4)(Fig.3 ).

c. When no any welding point leakage,it should be evaporator or condensor or inner pipe leakage inner pipe leakage can't be repair.discard the unit please.

Evaporter or condensor broken,replace it please.

d. After repair,refill the gas please.

2>.When only one zone isn't cooling or not cooling enough,the fault will happen on refrigerating parts.Check as below(the cooling system of every zone is same,the check means is same too,so we will

describe only one of them.

a. Test the valve by listening. Exchange the connectors of the valve when power off, then power on, listen carefully, a sound of 'tick' will be heard, otherwise the valve power off or broken, the valve power off means the PCB faulty or wiring problem, if all these are ok, replace the valve please.

b. If the valve is normal, it should be the capillary jammed. Repair it follow the means as foregoing

c. After repairing, make sure the cooling system is normal (no leakage or jammed), refill the refrigerant please.

3 . Refill the refrigerant:

1>. Using the vacuum pump form a vacuum in the system, via the joint of the low-pressure process pipe on the compressor (→5) (Fig.4 showing A) , the high-pressure pipeline is on the process pipe of the filter (Fig.4 showing G). Apply the vacuum pump for approximately 20 minutes. Until the vacuum is lower than 100Pa. Then solder the compressor process pipe of the filter. Keep the vacuum running while soldering this joint

2>. Fill Cooling system with refrigerant via the process pipe (→5) (Fig.4 showing A). (The refrigerant is R134a. Regarding refrigerant quantity Please refer to the instruction at back label of wine cellar). Then solder the compressor process pipe after the system is charged with refrigerant.

4. Running test:

Replace all the components after the procedures above and turn the unit on. To verify the effectiveness of the repair, monitor the unit the compressor should automatically stop within - 2.5 deg centigrade of the set temperature and start with +2.5 deg centigrade of the set temperature within approx 3 hours (assuming an ambient temperature of 32°C and the unit is empty).

- How to remove the air duct board

1. Take away the shelves, normally there three types of fixing means.

1> Shelf support: Drive up the shelves make it above the support, then take it out according to the arrowhead F direction (Fig.1)

2> Side wheel type: Drive the shelf to the end, then take up, and pull it flatly. ( 如图 Fig.1.1)

3> Bottom wheel type: Same as shelf support (Fig.1) .

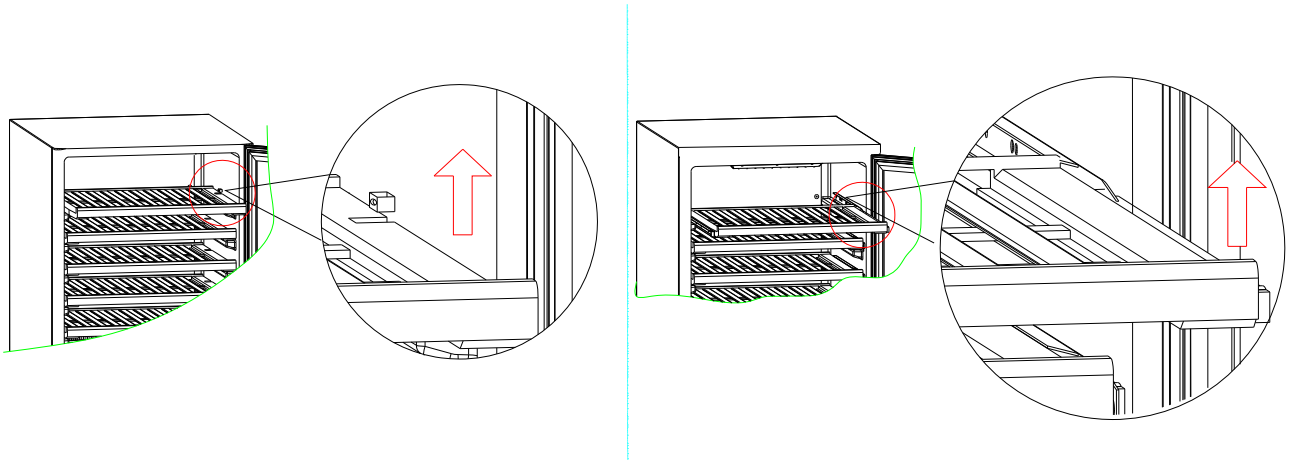

Fig. 1

Fig. 1.1

2. How to remove the middle airduct board: (noticed: the upper middle airduct board is same as lower middle airduct board, here describe one, the main PCB lay in lower middle airduct board)

a. Remove 2 fixing screws (1) of upper cover (A), then take it up, and out. (Fig.2.1)

Fig:2. 1

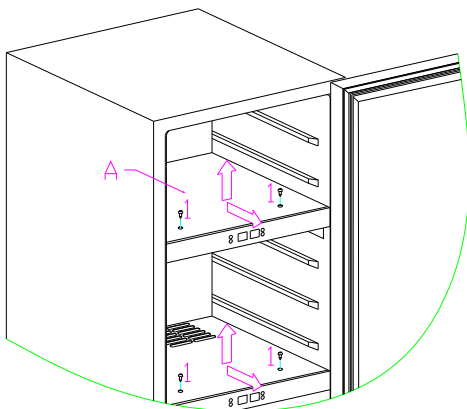

Fig:2. 2

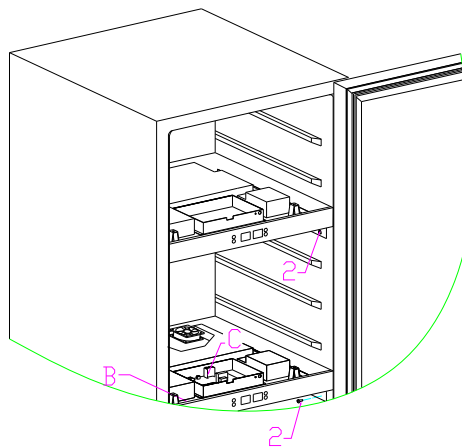
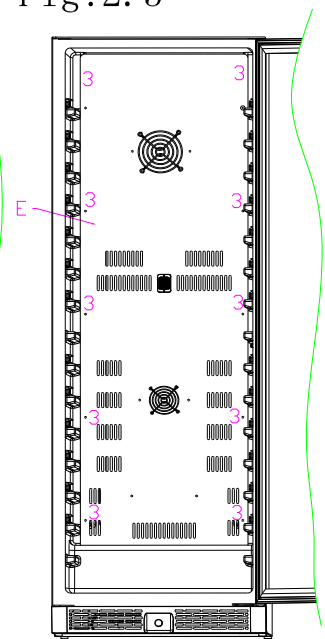

Fig:2. 3



b. Disconnect all connectors on the main PCB (except connectors of the display PCB). Remove 4 fixing screws (2) under the lower cover, pull out and take it away carefully. (Fig.2.2)

c. Remove the 10 fixing screws (3) of the airduct board (E), take it outward carefully (Fig.2.3), when the connectors of the sensor and fans reveal, disconnect them please.

d. The scene after taking away the airduct board show below. the evaporators are same. (Fig.3)

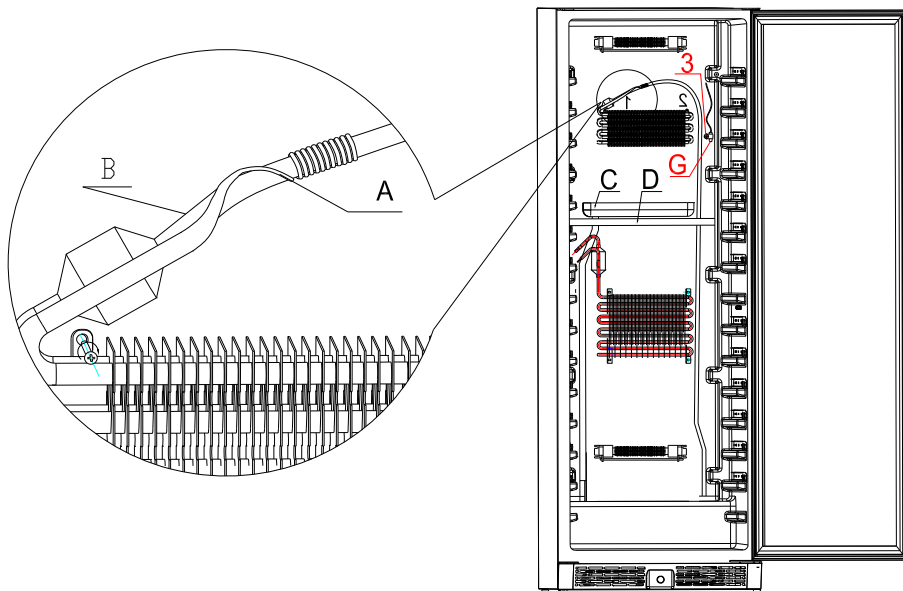

Fig. 3

○ Front side joints location. See (Fig.3)

A. Capillary soldered joints      B. evaporator soldered joints      C.water tank      D:dividing form

○ Rear side view of the joints position (Fig.4)

A. Process pipe soldered joint.      B. Anti-Dew pipe soldered joint  
 C.Suction pipe soldered of lower zone      D. Discharge pipe soldered joint  
 E.Suction pipe soldered of upper zone      F. Condenser soldered joint  
 G. Dry filter process pipe soldered joint.      H.Lower zone capillary soldered joint  
 I.Connecting pipe soldered joint      J.Valve soldered joint.  
 K.Upper zone capillary soldered joint

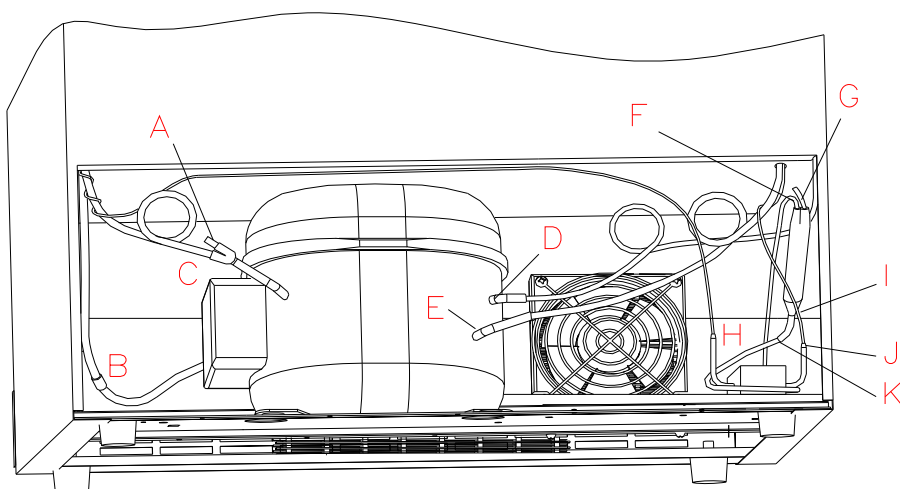

Fig. 4

▲ High noise of wine cellar

○ compressor noise

1. The working of motor and piston motion will cause noise when compressor working. So if noise is steady and not exceeds 42 dB, it's normal. If noise is not steady or very high, it's compressor fault and it should be repaired or replaced.

2. If compressor's shock absorption rubber is hardening or damaged, or fixing screw of compressor is too tight or loose, it will cause noise. The settlement is to change new shock absorption rubber or adjust fixing screws.

○ Fan noise

1. When the fans are running , the vanes are circumrotating rapidly and the air flows, which will cause steady and standard noise. The noise should not exceed 32dB and it is normal.

2. If the noise is extremely high and abnormal, the cause maybe as below

1>. The axis of the fan is broken

2>, The fan is broken and lost balance

3. How to replace the fans

The fan ruined and we could replace it with the same model's fan

1>. Take away the shelves(→3) (Fig.1 & Fig.1.1)

2>. Remove the airduct board. (→3) (Fig.2.1 & Fig.2.2 & Fig.2.3)

3>. Remove 4 fixing screws(1) of the fan,replace it with new one. ( Fig.5)

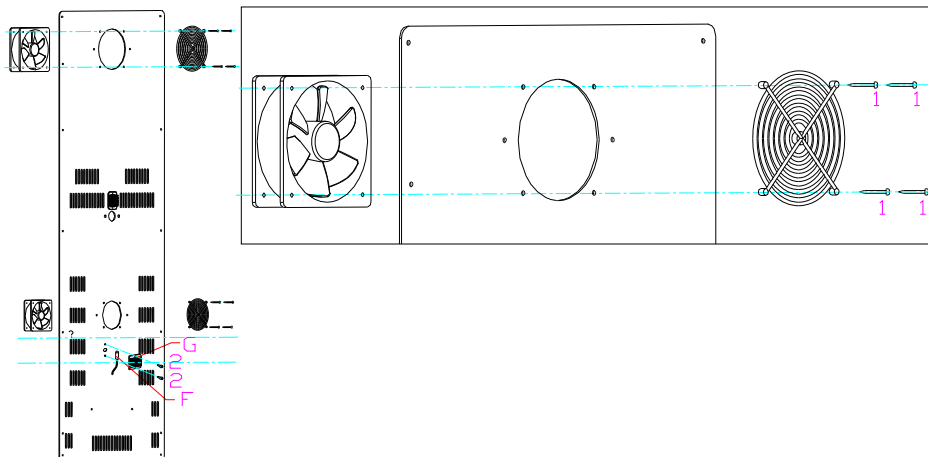

Fig. 5

4>. How to replace the condensor fan.

a. The connects of the condensor fan are connecte to the power PCB,refer 'how to remove the power PCB and transformer'.take apart the power PCB fixing box,then disconnect the connectors of the fan. (→10) (Fig.12.1 & Fig.12.2)

b. lean back the unit with angle 45°,remove the fixing screws(1,2) of the fan from bottom of the compressor branket with crossing head screwdriver.and replace it. (→5) (Fig.6 & Fig.6.1)

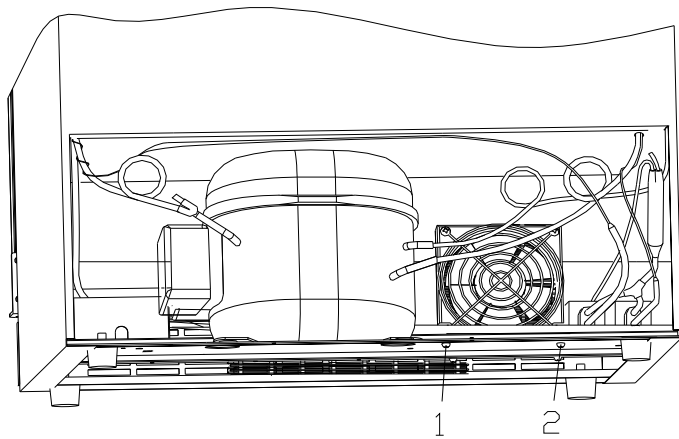

Fig. 6

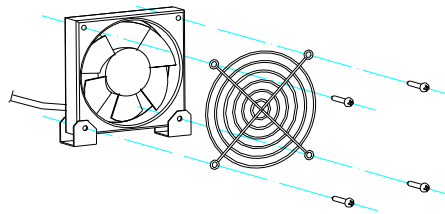

Fig.6.1

○ Refrigerant jet noise

Default: If there is intermittent noise like a water spray from the capillary.

Reason: The end of the capillary in the evaporator is in the wrong position, or there are rough edges on the end of the capillary

Resolvent:

- 1>. Heat the soldered joint of the capillary (“A” of Fig.3), then remove the capillary from the evaporator and smooth the end with an eraser. (Caution: do not allow any particles into capillary unit)
- 2>. Replace the capillary into the evaporator, then solder it back into the correct position (not exceeding 15mm in the evaporator) and pack the joint with anti vibration compound
- 3>. Recharge with refrigerant. See (Page3)

○ Capillary vibration noise

Default: high frequency impact noise in capillary zone.

Caused by either:

- 1>. The capillary being inserted too deep into the evaporator, so when the refrigerant is jetting, the end of vibrating capillary will hit the inside of the evaporator.
- 2>. Vibration from the capillary touching the inside of the cabinet or air duct board, then when refrigerant is jetting.

Solutions:

- 1>. If the capillary is inserted too deep, heat it with the soldering iron, solder it again (Please noted, the deep inserted is not bigger than 15mm), and vacuumize it and infill the refrigerant. (page3)
- 2>. If the capillary touch the inner cabinet and the air duct board, adjust the position of the capillary and add the incabloc plastic. (→4) (Fig.3)

Oil jammed noise

Fault: intermittent and deep jet noise coming from inside of the capillary.

Caused by: Compressor oil flowing into the cooling system pipe work because of wine cooler lean during transportation, and the jetting oil in the capillary cause noise.

Solutions:

Clean the cooling system pipe, and recharge with refrigerant see (page 2)

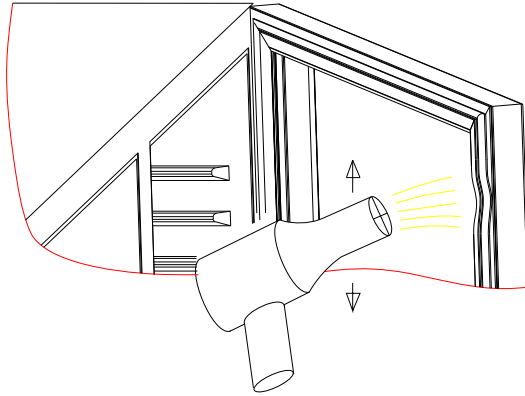

Fig. 7

▲ Evaporator freezing.

- Because the gasket is not air-proof, or the door is not closed well, cause much water fill in the the cabinet, and the water got frozen when it encounter the cold air, sometimes the ice is too thick, and it will block the fan or broken the fan.

The solution:

- 1>. Replace the door gasket or close the door well. If the door gasket is slightly not air-proof, it can be repaired by the heat dryer.  
Aiming at the distortion of the gasket with the heat dryer, and move up and down until it expand to the normal state. When it is cool, check it with the door closed, if there is any distortion, dry it again until it fix for the door. (Fig.7)
- 2 >.If the fan is damed seriously or brocken, replace it with the new fan(Fig.5)

▲ Unstable temperatures inside the cabinet.

The unstable temperature is caused by the evaporator fans cease, and it can be check by the below method: When the compressor is running, the light “Run” is on, the fan should be running, if the fan stop, check the whether is any fault in the fan or fan connection. If the fan is broken, replace it with the fan of the same model. (→5) (Fig.5 & Fig. 6 & Fig. 6.1 ).

▲ Control system fault

- Make use of self examination system to check the fault

Because the wine cellar series adopted computer control system, which is convenient for the maintenance and examination of the wine cellar, and there is the self examination in the computer board.

If there is any doubt about the fault of the control system, please apply the self-examination system. The method is following:

- 1 > . Press up and down at the same time, turn the power, enter the self examination system after hearing two

beeps.

2 > . The normal self examination phenomenon as following:

- a. No answer after pressing key;
- b. The display tune show "—" ;
- c. The compressor works non-stop, and the induction light "RUN" is on ;
- d. The fan of the evaporator, the condenser running speedily and the refrigerant valve switch one time per 3 seconds ;
- e. The light switch normally is controlling the light.

3 > . If the above a-e point is line in the situation, and every components of the mechine is normal; if there is any different, and firstly check the abnormal components and their connection wire. If the connection is tight, replace the components. If the replacement fail, it can be judged as control panel's fault, please replace it with the same module. (→9、→10、→11、) ( Fig.9 & Fig.10 & Fig.11 & Fig.12.1 & Fig.12.2 & Fig.12.3)

4 > . Unplug the plug to exit the self-examination system.

#### ○ Sensor fault

1 . After turning on the power, if the LED display shows the temperature is similar with the ambient temperature, it is normal, if abnormal, please remove the upper cover of the lower middle airduct board, (→3) (Fig.2.1), check the sensor insert whether reliable. If the insert is reliable, it is the sensor's fault, replace the sensor with the same module.

1> . The LED display shows E1, and it is the upper zone's sensor open circuit fault, check the connection wire and the main board whether plough, if not , replace the sensor with the same module. See(→5) (Fig.5.)

2> . If the LED displays "E2" indicates upper zone's sensor short circuit fault, check the connection wire and the main board whether it is in good condition, if yes,the sensor should be replaced see (→5) (Fig.5)

3> . The LED display shows E3, and it is the middle zone's sensor open circuit fault, check the connection wire and the main board whether plough, if not, replace the sensor with the same module. See(→5) (Fig.5.)

4> . If the LED displays "E4" indicates middle zone's sensor short circuit fault, check the connection wire and the main board whether it is in good condition,if yes,the sensor should be replaced see (→5) (Fig.5)

5> . The LED display shows E7, and it is the lower zone's sensor open circuit fault, check the connection wire and the main board whether plough, if not, replace the sensor with the same module. See(→5) (Fig.5.)

6> . If the LED displays "E8" indicates middle zone's sensor short circuit fault, check the connection wire and the main board whether it is in good condition,if yes,the sensor should be replaced see (→5) (Fig.5)

○ How to replace the sensor

1. The sensors are fixing on the airduct board(the same in all zones)

1> . Remove the shelves (→3) (Fig. 1& Fig.1.1)

2> . Remove the airduct board (→5) (Fig. 6& Fig. 6.1)

3> . Pull out 2 fixing plastic nails(2),the cover of the sensor will loose down,take away the sensor(F),replace it(→5) (Fig.5).

○ Valve default

1 > . If any one of upper and middle is normal,the other one is not cooling or temp too low(lower than setting temp more than 3°C),check the valve.

2 > . When power off, exchange the connectors of the valve,turn on the power,listen to the valve carefully,there is a 'tick'sound from it,otherwise confirming the PCB is ok,replace the valve.

3 > . How to replace the valve:

a. Heat the solder joint H,K,J with soldering iron and take apart the valve. (Fig. 8)

b. Remove 2 screws(1) (Fig.8)

c. Replace the valve with new one,then vacuum the unit and refill.

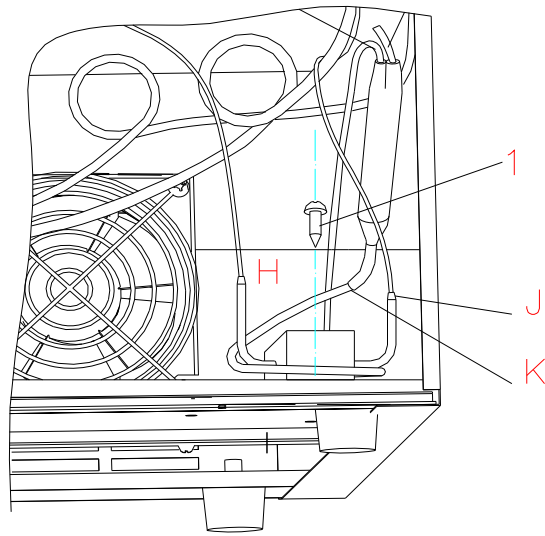

Fig. 8

- Display PCB fault

Replace the displace PCB (→8) (Fig.9).

- How to remove the controller PCBs

**Notice:There are two PCB in the unit,one is main PCB,fixing in the lower middle airduct board,the other is power PCB,fixing in the electrical box with transformer on the left-hand side of the compressor.**

1 . How to remove the main PCB.

1 > . Disconnect all connectors one by one,pinch the head of the plastic nails(4),take up the PCB at the same time,take away the PCB from nails,replace it please( Fig. 9) ( Vlew K ) ,

2 > . How to replace the displace PCB:

Open the fixing part( D )slightly according to the arrowhead in the view I, take apart the displace PCB support ( F ) ,then pull 4 hooks of the support ( F ) according to the arrowhead,take apart the displace PCB(E),disconnect the connectors,replace it please.( Fig. 9) ( Vlew I )

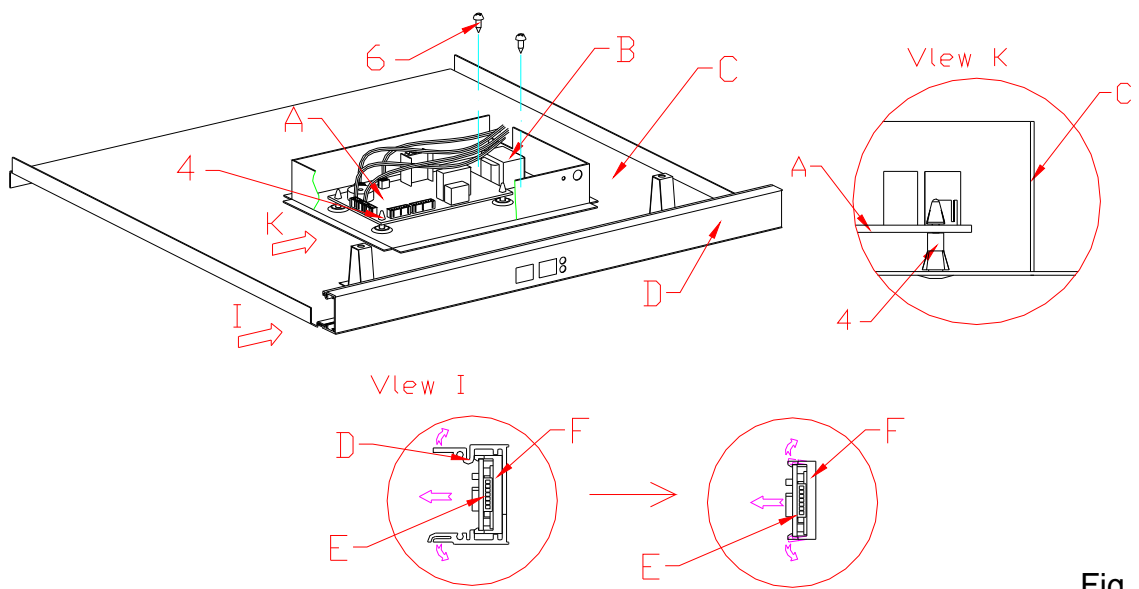

Fig. 9

○ Layout of main PCB ( Fig. 10)

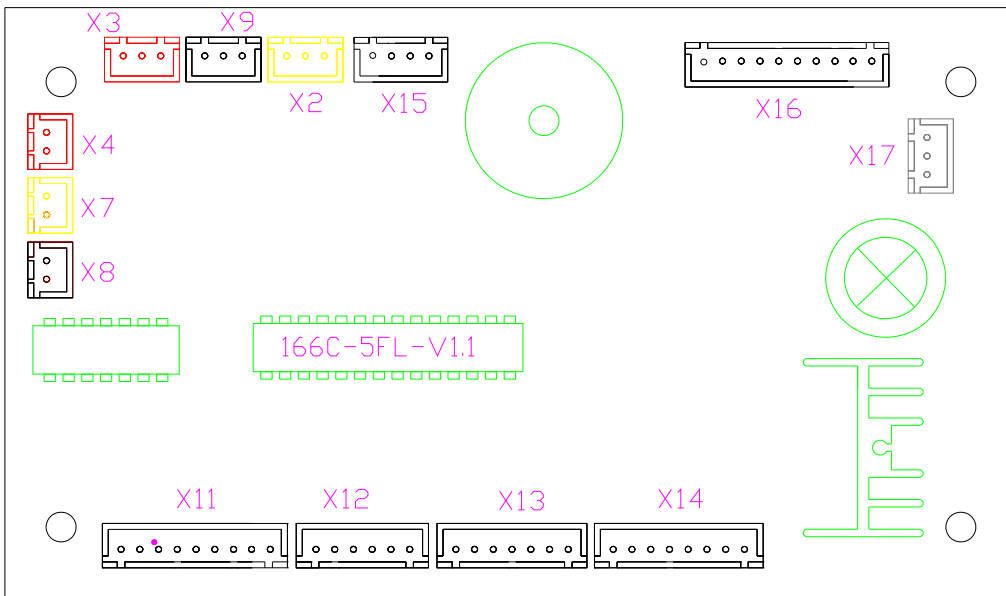

Fig. 10

- X2: To upper fan(yellow)
- X3: To lower fan(red)
- X4: To lower sensor(red)
- X7: To upper sensor(yellow)
- X8: To middle sensor(white)
- X9: To middle fan(white)
- X11: To lower display PCB(X301)
- X12: To lower display PCB(X302)
- X13: To upper display PCB(X201)
- X14: To upper display PCB(X202)

- X15: To LED light(white)
- X16: To power PCB
- X17: To lower heater fan(black)

○ Layout of power PCB ( Fig. 11)

- |                            |                             |
|----------------------------|-----------------------------|
| 1.To transformer primary-L | 2.To power-L                |
| 3.To power-N               | 4.To transformer primary-N  |
| 5.To PTC heater            | 6.To compressor             |
| 7.To valve                 | 8.To main PCB (white)       |
| 9.To condensor fan(red)    | 10.To transformer secondary |

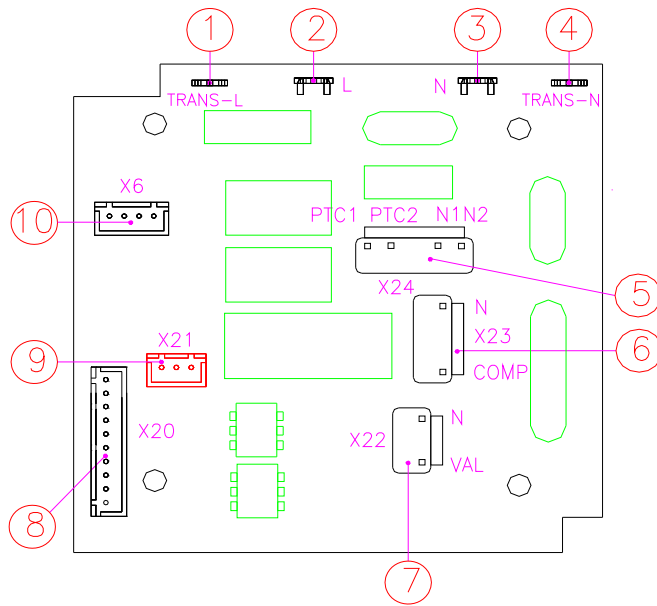
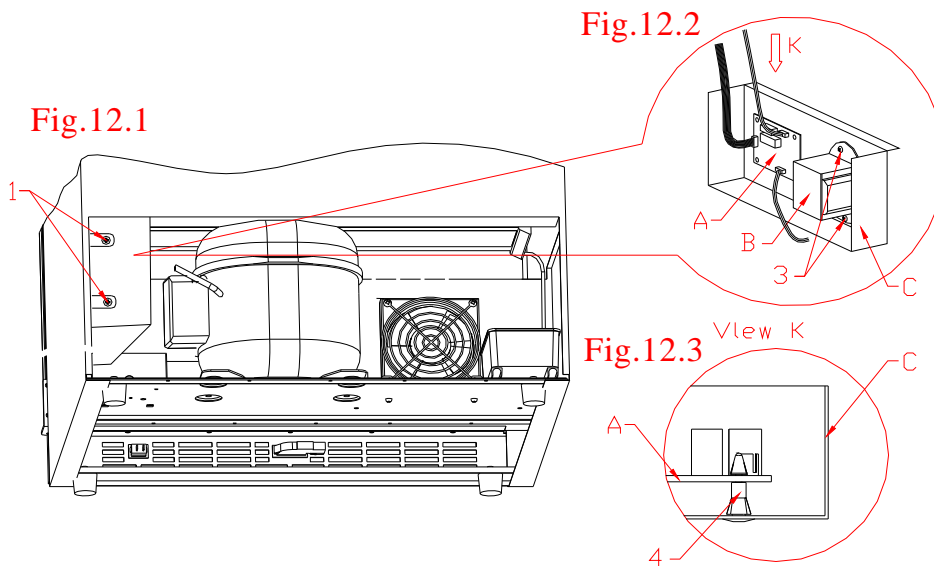

Fig. 11

○How to remove the power PCB and transformer

- 1 > . Remove 2 fixing screws(1) of the electrical box;( Fig.12.1)
- 2 > . Take apart the electrical box( Fig.12.2)
- 3 > . Disconnect all connectors,pinch the plastic nails(4),pull up the PCB(A),take apart the PCB,replace it please.( Fig.12.3) (Vlew K)
- 4> . Connect all connectors, ( Fig.11 )
- 5> . Remove 2 fixing screws(B) of the transformer(3),disconnect the connectors,and replace it.( Fig.12.2)



○ How to replace the LED light

1. How to replace the upper LED light (Fig.13)

1>, Take away the upper zone shelves;(→3) (Fig.1& Fig.1.1 )

2>, Remove 2 fixing screws(7) of the light cover(B),take apart the cover.(Fig.13)

3>, Remove the fixing screws of the LED light PCB(B),disconnect the connector(E),replace the light PCB please.

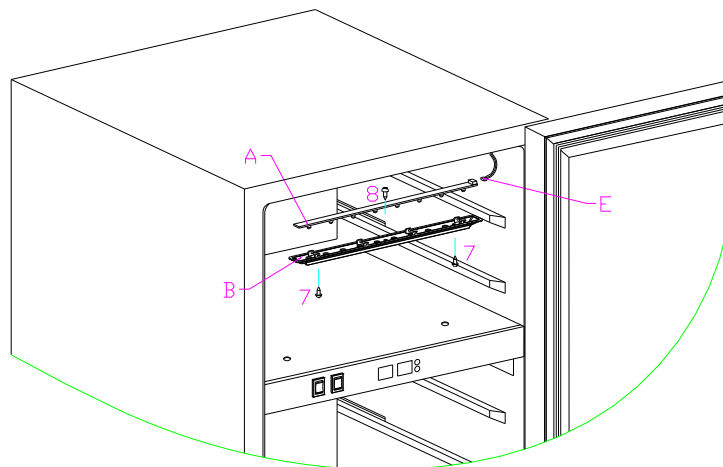

Fig. 13

2. How to replace middle and lower LED light:(Fig.14)

1>, Take apart the shelves(→3) (Fig.1& Fig.1.1 )

2>, Disconnect the upper cover of the middle airduct board.(→3) (Fig.2.1)

3>, Disconnect the connector(C),pinch the head of the plastic nail,pull up the display,take the PCB away from nail one by one,and take apart the light PCB,replace it.( Fig.14)

Notice:it is not need to take the lower cover of the airduct board.

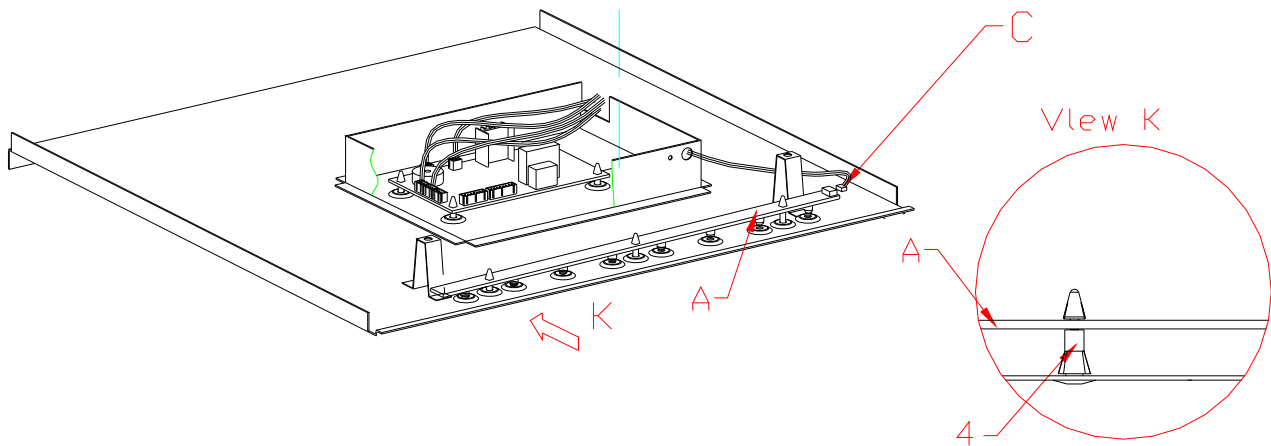

Fig. 14

▲ The heater default

○ How to diagnose the default

If the temperature of refrigeration compartment is ( $-2^{\circ}\text{C}$ ) lower than setting temperature for an empty unit (assuming ambient temp of over 0 degrees centigrade and continuous operation and normal temperature of the refrigerating compartment), check the heater fan and PTC heater. If both are working normally, there is probably a heating system fault.

○ How to repair the fault:

1 . How to check the heater fan.

If the temperature of refrigeration compartment is lower than set temperature but heater fan does not function, after verifying no bad connections replace the fan unit .

2 . How to check the PTC heater

Check the resistance at both sides of PTC heater using a Multi meter; the reading should be approx  $1.5\text{ K}\Omega$  (assuming normal temperature), if open circuits Replace the PTC heater having once verified the connections to the PTC heater. replace new one. See (Fig.19).

3. If no fault in the fan or PTC heater, replace the control panel, see (Page 20-23).

○ How to replace the PTC heater

1>. Take away the shelves( $\rightarrow$ 3) (Fig.1& Fig.1.1 )

2>. Take apart the airduct board( $\rightarrow$ 3 ) (Fig.2.1 & Fig.2.2 & Fig.2.3 )

3>. Remove the fixing screws of heater,replace it. (Fig.15)

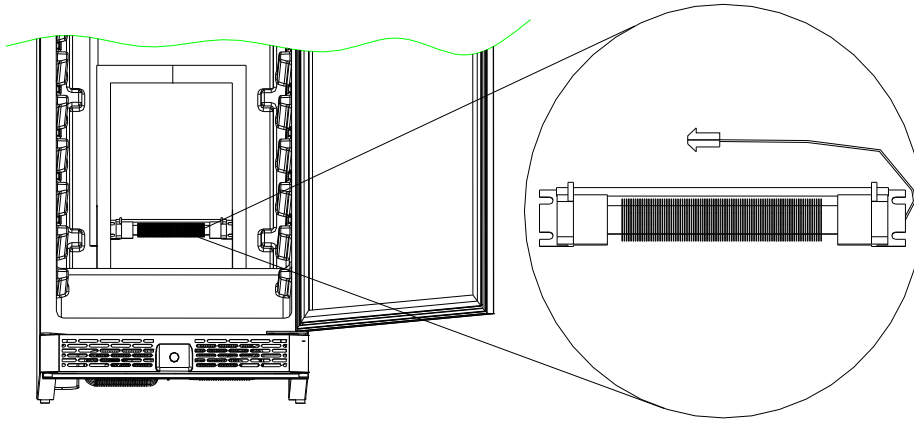

Fig. 15

4 .If it is PCB broken,replace it please. (Fig. 9)

# SERVICE MANUAL

Three temperature zone control wine cooler

JG166C

The content below shows different default might happen when the wine cooler is working, and also shows how to find the defaults and repair the defaults. Please find the corresponding default statement and find the repair information in the corresponding pages.

---

Statement: (Fig.4 ) shows the correlative diagram Fig.4

( →6 ) shows the correlative page 6

**WARNING: Before attempting any cleaning or maintenance this unit Must be disconnected from the electrical supply, to prevent electrical shock.**

---

▲ Preparation before maintenance

○ Tools

1. Pliers
2. Phillips head screwdrivers
3. Process pipe
4. Electrical Multi meter
5. Amp meter (5A) (caliper cable type)
6. Electrical soldering iron
7. Wire strippers
8. Seal pliers
- 9/ Scissors

○ Equipment

1. Vacuum pump
- 2.Soldering iron for copper pipes
- 3.Gas meter

▲ Cooling system fault

- How to Evaluate the fault .....(Page 2)
- How to repair the fault ... (Page 2)
- How to remove the air duct board ..... (Page 3)
- Diagram showing the front side soldered joints .....(Page 4)
- Diagram showing the rear side soldered joints .....(page 5)

▲ Noise problems

- Compressor noise .....(Page 5)
- Fan noise .....(Page 5)
- Refrigerant jet noise ..... (Page 6)
- Capillary vibration noise .....(Page 6)
- Oil jam noise .....(Page 7)

▲ Evaporator freezing problems .....(Page 7)

▲ Unstable internal temperature problems .....(Page 7)

▲ Control system problems

- Fault finding by the self-check mode .....(Page 8 )
- Sensor fault .....(Page 8)
- HI, LO alarm .....(Page 8)
- How to replace the sensor .....(Page 9)
- LED display fault .....(Page 10)
- How to remove parts inside of electrical box ..... (Page 10)
- How to replace the light ..... (Page12)

▲ Heating system fault

- How to Evaluate the fault .....(Page 13)
- How to repair the fault .....(Page 14)

△ Cooling system faults.

- How to diagnose faults:

It should take approximate 3 hours to reach the lowest setting temperature of 5°C for an empty unit (assuming ambient temp of 32 degrees centigrade and continuous operation). If not, check the compressor, cooling fans, controller, and sensors. If all these are working normally, there is probably a cooling system's fault.

- How to repair the default

1. Check the compressor

Turn on the unit and check there is electricity current flowing to the compressor using a caliper type Amp meter, the current should be within 0.6 to 2 Amps. If the readings are not in this range, turn off and cut off the pipes (See Fig.4 showing D) and the process pipe (See Fig.4 showing A.) from the compressor, then turn the unit on again (**in this case only run the compressor for a few minuets, so as to avoid the compressor absorb moist air**) and recheck the current and if there is pressure at the outlet pipe. If the current reading is still out of range specified above and no pressure from the compressor outlet, replace the whole compressor.

2 . Check the cooling system

1>.Carefully check the cooling system after verifying the compressor is working normally when no zone cooling. It will be refrigerant leakage, follow the procedure below.

a. Cut off the process pipe and discharge pipe. infill 0.8—1Mpa nitrogen by process pipe. Put you hand near to the discharge pipe and the back of the hand face to the discharge pipe cut kerf. If there is a little gas leak from the terminal, it means normal, or capillary is jamed. (notice: there are two capillary in this unit, normally only one capillary with gas flow,if no any gas leak from discharge pipe, it means one capillary is jamed. Please switch the valve and try again to see if the other capillary is jamed. Refer to 'check the valve' to switch the valve).

b. Infill 0.8-1MPa nitrogen, and check the welding point around the compressor (→5) (Fig.4 ) with soap water. If there isn' t any leakage, please take apart the air-duct board(→3、 →4) (Fig.2.1 & Fig.2.2 & Fig.2.3 & Fig.3) and check the welding point around the evaporator(→4)(Fig.3 ).

c. When no any welding point leakage, it should be evaporator or condenser or inner pipe leakage inner pipe leakage can' t be repair. discard the unit please.

Evaporator or condenser broken, replace it please.

d. After repair, refill the gas please.

2>.When only one zone isn' t cooling or not cooling enough, the fault will happen on refrigerating parts. Check as below(the cooling system of every zone is same, the check means is same too, so we

will describe only one of them.

a. Test the valve by listening. Exchange the connectors of the valve when power off, then power on, listen carefully, a sound of 'tick' will be heard, otherwise the valve power off or broken, the valve power off means the PCB faulty or wiring problem, if all these are ok, replace the valve please.

b. If the valve is normal, it should be the capillary jamed. Repair it follow the means as foregoing

c. After repairing, make sure the cooling system is normal(no leakage or jamed), refill the refrigerant please.

### 3 . Refill the refrigerant:

1>. Using the vacuum pump form a vacuum in the system, via the joint of the low-pressure process pipe on the compressor(→5) (Fig.4 showing A), the high-pressure pipeline is on the process pipe of the filter(Fig.4 showing G). Apply the vacuum pump for approximately 20 minutes. Until the vacuum is lower than 100Pa. Then solder the compressor process pipe of the filter. Keep the vacuum running while soldering this joint

2>.Fill Cooling system with refrigerant via the process pipe(→5 ) (Fig.4 showing A). (The refrigerant is R134a. Regarding refrigerant quantity Please refer to the instruction at back label of wine cellar). Then solder the compressor process pipe after the system is charged with refrigerant.

### 4. Running test:

Replace all the components after the procedures above and turn the unit on. To verify the effectiveness of the repair, monitor the unit the compressor should automatically stop within - 2.5 deg centigrade of the set temperature and start with +2.5 deg centigrade of the set temperature within approx 3 hours (assuming an ambient temperature of 32°C and the unit is empty).

#### ○ How to remove the air duct board

1. Take away the shelves, normally there three types of fixing means.

1> Shelf support: Drive up the shelves make it above the support, then take it out according to the arrowhead F direction(Fig.1)

2> Side wheel type:Drive the shelf to the end ,then take up,and pull it flatly. (如图 Fig.1.1)

3> Bottom wheel type:Same as shelf support(Fig.1) .

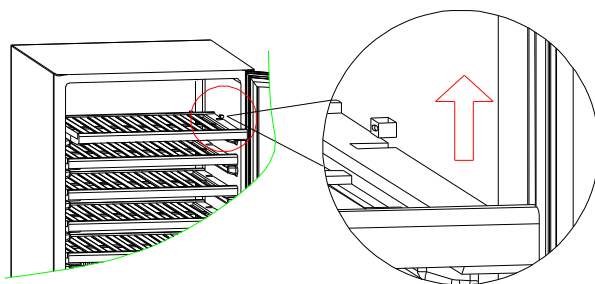

Fig. 1

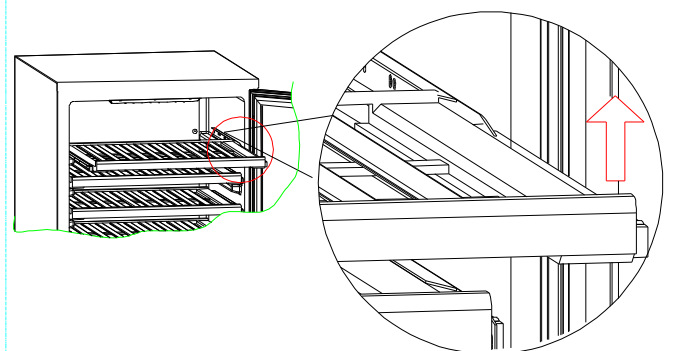

Fig. 1.1

2.How to remove the middle air-duct board:(noticed: the upper middle air-duct board is same as lower middle air-duct board, here describe one, the main PCB lay in lower middle air-duct board)

a. Remove 2 fixing screws(1) of upper cover(A),then take it up, and out. (Fig.2.1)

Fig:2.1

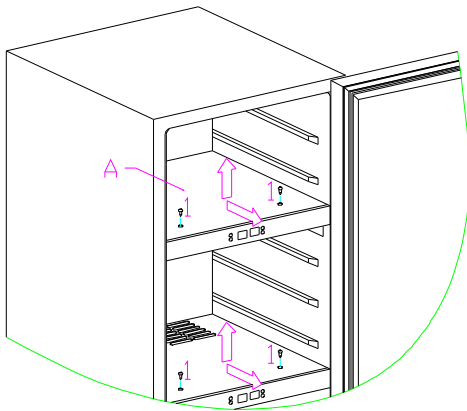

Fig:2.2

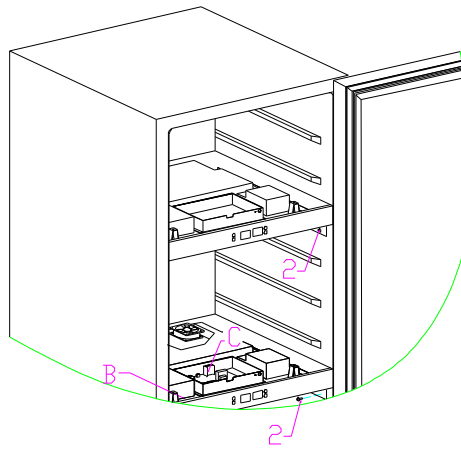
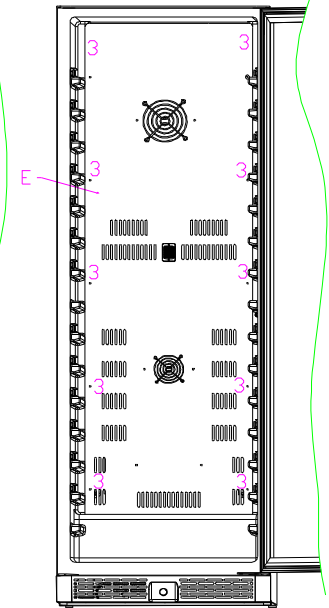

Fig:2.3



b. Disconnect all connectors on the main PCB(except connectors of the display PCB) .Remove 4 fixing screws(2) under the lower cover, pull out and take it away carefully. (Fig.2.2)

c. Remove the 10 fixing screws(3) of the air-duct board(E),take it outward carefully(Fig.2.3),when the connectors of the sensor and fans reveal, disconnect them please.

d. The scene after taking away the air-duct board show below. the evaporators are same. (Fig.3 )

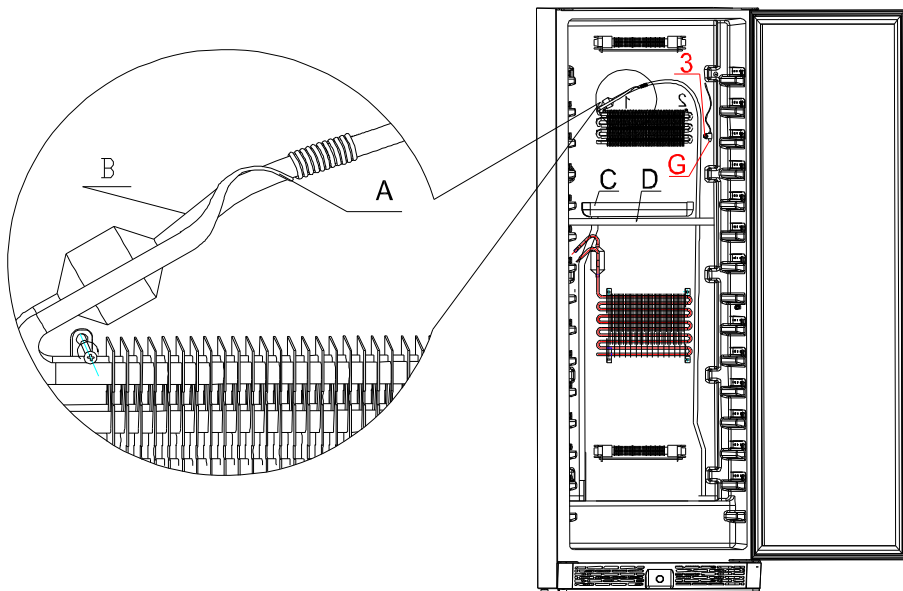

Fig. 3

○ Front side joints location. See (Fig.3 )

A. Capillary soldered joints      B. evaporator soldered joints      C.water tank      D.dividing form

○ Rear side view of the joints position (Fig.4)

A. Process pipe soldered joint.      B. Anti-Dew pipe soldered joint  
 C. Suction pipe soldered of lower zone      D. Discharge pipe soldered joint  
 E. Suction pipe soldered of upper zone      F. Condenser soldered joint  
 G. Dry filter process pipe soldered joint.      H. Lower zone capillary soldered joint

I. Connecting pipe soldered joint

J. Valve soldered joint.

K. Upper zone capillary soldered joint

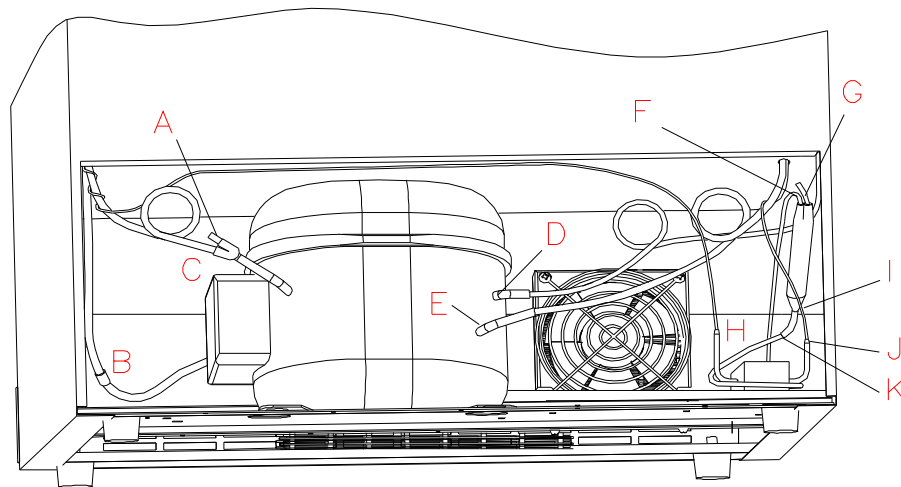

Fig. 4

▲ High noise of wine cellar

○ compressor noise

1. The working of motor and piston motion will cause noise when compressor working. So if noise is steady and not exceeds 42 dB, it's normal. If noise is not steady or very high, it's compressor fault and it should be repaired or replaced.

2. If compressor's shock absorption rubber is hardening or damaged, or fixing screw of compressor is too tight or loose, it will cause noise. The settlement is to change new shock absorption rubber or adjust fixing screws.

○ Fan noise

1. When the fans are running, the vanes are circumrotating rapidly and the air flows, which will cause steady and standard noise. The noise should not exceed 32dB and it is normal.

2. If the noise is extremely high and abnormal, the cause maybe as below

1>. The axis of the fan is broken

2>. The fan is broken and lost balance

3. How to replace the fans

The fan ruined and we could replace it with the same model's fan

1>. Take away the shelves(→3) (Fig.1 & Fig.1.1)

2>. Remove the air-duct board. (→3) (Fig.2.1 & Fig.2.2 & Fig.2.3)

3>. Remove 4 fixing screws(1) of the fan, replace it with new one. (Fig.5)

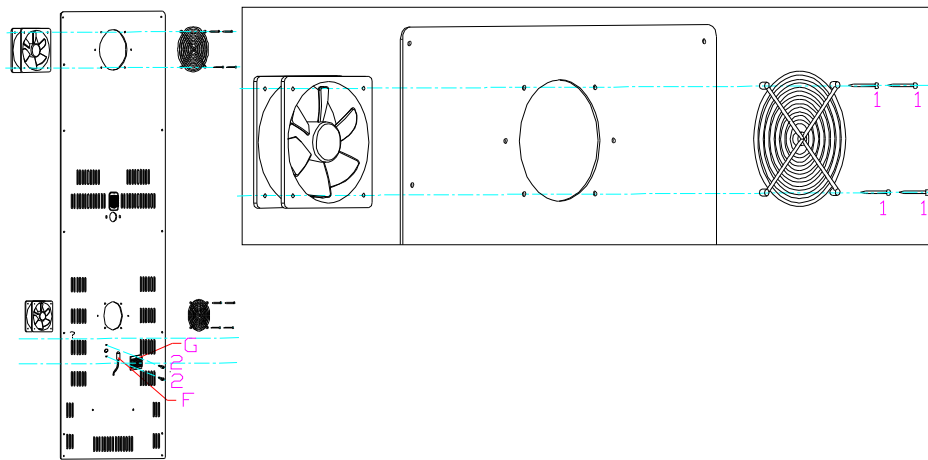

Fig. 5

4>. How to replace the condenser fan.

a. The connects of the condenser fan are connect to the power PCB, refer ‘how to remove the power PCB and transformer’. take apart the power PCB fixing box, then disconnect the connectors of the fan. (→10) (Fig.12.1 & Fig.12.2)

b. lean back the unit with angle 45° ,remove the fixing screws(1,2) of the fan from bottom of the compressor branket with crossing head screwdriver. and replace it. (→5) (Fig.6 & Fig.6.1)

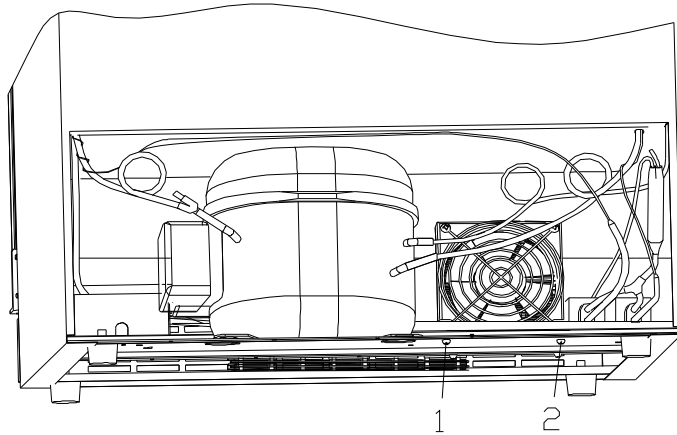

Fig. 6

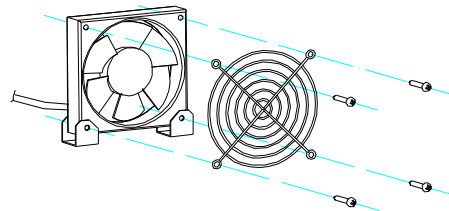

Fig.6.1

○ Refrigerant jet noise

Default: If here is intermittent noise like a water spray from the capillary.

Reason: The end of the capillary in the evaporator is in the wrong position, or there are rough edges on the end of the capillary

Resolvent:

1>. Heat the soldered joint of the capillary (“A” of Fig.3), then remove the capillary from the evaporator and smooth the end with an eraser. (Caution: do not allow any particles into capillary unit)

2>. Replace the capillary into the evaporator, then solder it back into the correct position (not exceeding 15mm in the evaporator) and pack the joint with anti vibration compound

3>. Recharge with refrigerant. See (Page3)

○ Capillary vibration noise

Default: high frequency impact noise in capillary zone.

Caused by either:

1>. The capillary being insert too deep into the evaporator, so when the refrigerant is Jetting, the end of

vibrating capillary will hit the inside of the evaporator.

2>. Vibration from the capillary touching the inside of the cabinet or air duct board, then when refrigerant is jetting.

Solutions:

1>. If the capillary is inserted too deep, heat it with the soldering iron, solder it again(Please noted, the deep inserted is not bigger than 15mm), and vacuumize it and infill the refrigerant. (page3)

2>. If the capillary touch the inner cabinet and the air duct board, adjust the position of the capillary and add the incabloc plastic. (→4) (Fig.3 )

### Oil jammed noise

Fault: intermittent and deep jet noise coming from inside of the capillary.

Caused by: Compressor oil flowing into the cooling system pipe work because of wine cooler lean during transportation, and the jetting oil in the capillary cause noise.

Solutions:

Clean the cooling system pipe, and recharge with refrigerant see (page 2)

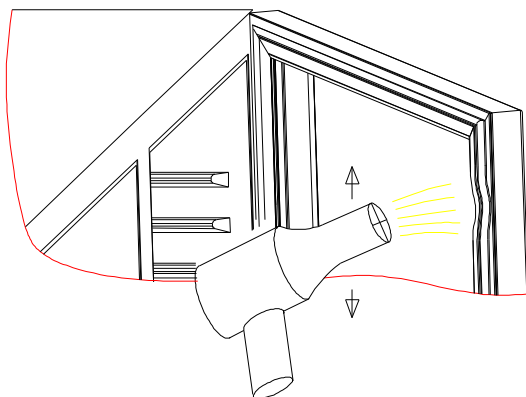

Fig. 7

### ▲ Evaporator freezing.

- Because the gasket is not air-proof, or the door is not closed well, cause much water fill in the cabinet, and the water got frozen when it encounter the cold air, sometimes the ice is too thick, and it will block the fan or broken the fan.

The solution:

1>. Replace the door gasket or close the door well. If the door gasket is slightly not air-proof, it can be repaired by the heat dryer.

Aiming at the distortion of the gasket with the heat dryer, and move up and down until it expand to the normal state. When it is cool, check it with the door closed, if there is any distortion, dry it again until it fix for the door. (Fig.7)

2 >.If the fan is damaged seriously or broken, replace it with the new fan(Fig.5)

### ▲ Unstable temperatures inside the cabinet.

The unstable temperature is caused by the evaporator fans cease, and it can be check by the below method: When the compressor is running, the light “Run” is on, the fan should be running, if the fan stop, check the whether is any fault in the fan or fan connection. If the fan is broken, replace it with the fan of the same model. (→5) (Fig.5 & Fig. 6 & Fig. 6.1 ).

## ▲ Control system fault

### ○ Make use of self examination system to check the fault

Because the wine cellar series adopted computer control system, which is convenient for the maintenance and examination of the wine cellar, and there is the self examination in the computer board.

If there is any doubt about the fault of the control system, please apply the self-examination system. The method is following:

- 1 >. Press up and down at the same time, turn the power, enter the self examination system after hearing two beeps.
- 2 >. The normal self examination phenomenon as following:
  - a. No answer after pressing key;
  - b. The display tune show “— —”;
  - c. The compressor works non-stop, and the induction light “RUN” is on;
  - d. The fan of the evaporator, the condenser running speedily and the refrigerant valve swich one time per 3 seconds;
  - e. The light switch normally is controlling the light.
- 3 >. If the above a~e point is line in the situation, and every components of the machine is normal; if there is any different, and firstly check the abnormal components and their connection wire. If the connection is tight, replace the components. If the replacement fail, it can be judged as control panel’s fault, please replace it with the same module. (→9、→10、→11、) ( Fig.9 & Fig.10 & Fig.11 & Fig.12.1 & Fig.12.2 & Fig.12.3)
- 4 >. Unplug the plug to exit the self-examination system.

### ○ Sensor fault

1. After turning on the power, if the LED display shows the temperature is similar with the ambient temperature, it is normal, if abnormal, please remove the upper cover of the lower middle airduct board, (→3) (Fig.2.1), check the sensor insert whether reliable. If the insert is reliable, it is the sensor’s fault, replace the sensor with the same module.

1>. The LED display shows E1, and it is the upper zone’s sensor open circuit fault, check the connection wire and the main board whether plough, if not , replace the sensor with the same module. See(→5) (Fig.5.)

2>. If the LED displays “E2” indicates upper zone’s sensor short circuit fault, check the connection wire and the main board whether it is in good condition, if yes, the sensor should be replaced see (→5) (Fig.5)

3>. The LED display shows E3, and it is the middle zone’s sensor open circuit fault, check the connection wire and the main board whether plough, if not, replace the sensor with the same module. See(→5) (Fig.5.)

4>. If the LED displays “E4” indicates middle zone’s sensor short circuit fault, check the connection wire and the main board whether it is in good condition, if yes, the sensor should be replaced see (→5) (Fig.5)

5>. The LED display shows E7, and it is the lower zone’s sensor open circuit fault, check the connection wire and the main board whether plough, if not, replace the sensor with the same module. See(→5) (Fig.5.)

6>. If the LED displays “E8” indicates the lower zone’s sensor short circuit fault, check the connection wire and the main board whether it is in good condition, if yes, the sensor should be replaced see (→5) (Fig.5)

7 >. The LED display shows HI, and it is the high temperature protection indication. After running 10 hours with power, if the inner temperature over 23<sup>0</sup>C. the LED display H I. When the HI shows for an hour,

then the HI twinkling , buzzer the alarm. And after the HI is continuous to twinkle for 20 minutes more, the compressor will stop working , and it need to be cut off power to stop the alarm.

The reason and the solution of this phenomena is as following.

- A. If all the upper and middle and/or lower zone show HI, the reason is refrigerant leakage cause the cooling fault. Find the leakage point, and weld it again, vacuumize and refill. (→2)
- B. If any zone shows HI, the reason is as following:
  - a. Because the capillary is blocked, not cooling, please do as the above method. (→2)
  - b. The refrigerator valve damage and can not be switch, cause not cooling, replace with the new one. (Fig.8)
  - c. The evaporator fan do not move, repair it.

8 >. The LED display shows LO, it is the low temperature protection indication. The principle is when the temperature of the cabinet is lower than 0°C, the system start up low temperature protection function, and now the LED display shows LO, and the buzzer alarm, the machine is forced to stop, so as to protect the wine from damage. When the temperature of the cabinet is higher than 0°C, the protection will dismiss automatically, and the LED display show the actual temperature.

Note: the LO usually appear when the temperature set between 4~6°C, if the temperature set higher than 6°C, LO appear, and it is abnormal, the resolution is check whether there is any voltage outlet the refrigerant valve , if no, change the control board.

○ How to replace the sensor

1. The sensors are fixing on the air-duct board(the same in all zones)

1>. Remove the shelves (→3) (Fig. 1& Fig.1.1)

2>. Remove the air-duct board (→5) (Fig. 6& Fig. 6.1)

3>. Pull out 2 fixing plastic nails(2),the cover of the sensor will loose down, take away the sensor(F),replace it(→5) (Fig.5).

○ Valve default

1 >. If any one of upper and middle is normal, the other one is not cooling or temp too low(lower than setting temp more than 3°C),check the valve.

2 >. When power off, exchange the connectors of the valve, turn on the power, listen to the valve carefully, there is a 'tick' sound from it, otherwise confirming the PCB is ok, replace the valve.

3 >. How to replace the valve:

a. Heat the solder joint H,K,J with soldering iron and take apart the valve. (Fig. 8)

b. Remove 2 screws(1) (Fig.8)

c. Replace the valve with new one, then vacuum the unit and refill.

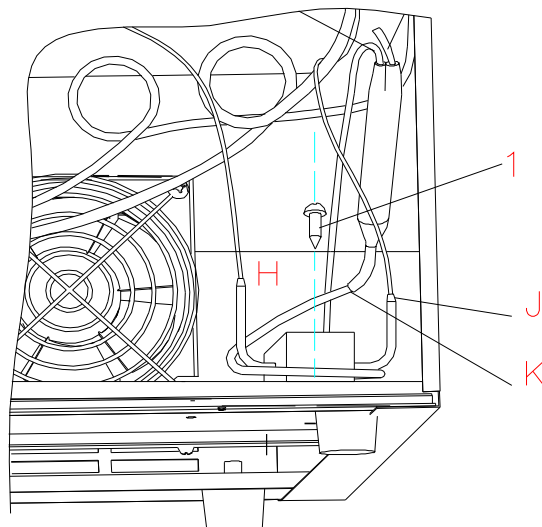

Fig. 8

- Display PCB fault  
Replace the displace PCB (→8) (Fig.9).

- How to remove the controller PCBs

**Notice: There are two PCB in the unit, one is main PCB, fixing in the lower middle airduct board, the other is power PCB, fixing in the electrical box with transformer on the left-hand side of the compressor.**

1 . How to remove the main PCB.

1 >. Disconnect all connectors one by one, pinch the head of the plastic nails(4),take up the PCB at the same time, take away the PCB from nails, replace it please( Fig. 9) ( Vlew K ),

2 >. How to replace the displace PCB:

Open the fixing part (D) slightly according to the arrowhead in the view I, take apart the displace PCB support (F) ,then pull 4 hooks of the support (F) according to the arrowhead, take apart the displace PCB(E),disconnect the connectors, replace it please.( Fig. 9) ( Vlew I )

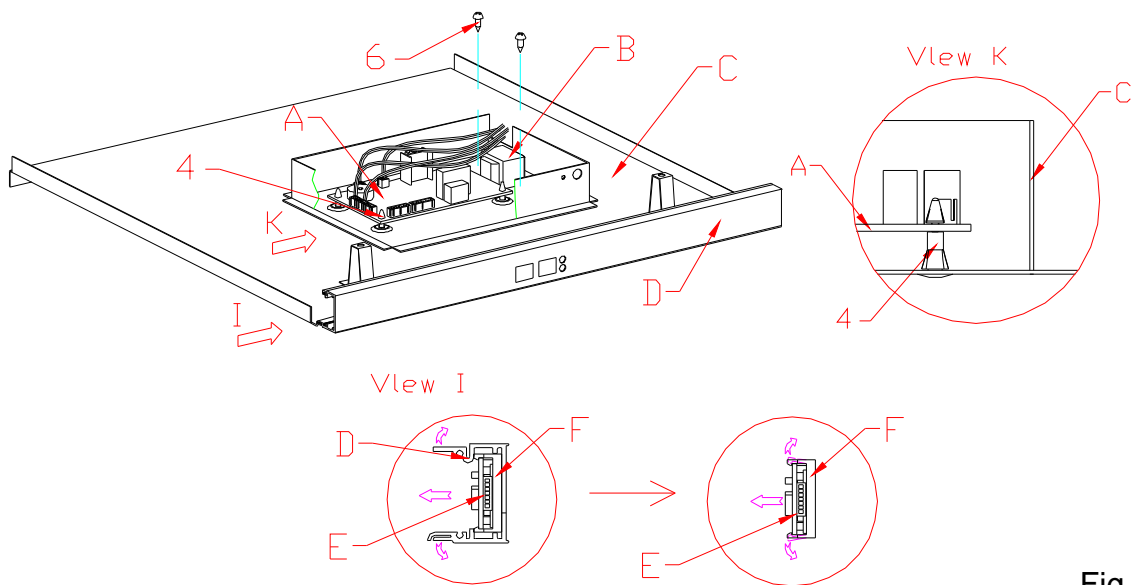

Fig. 9

- Layout of main PCB ( Fig. 10)

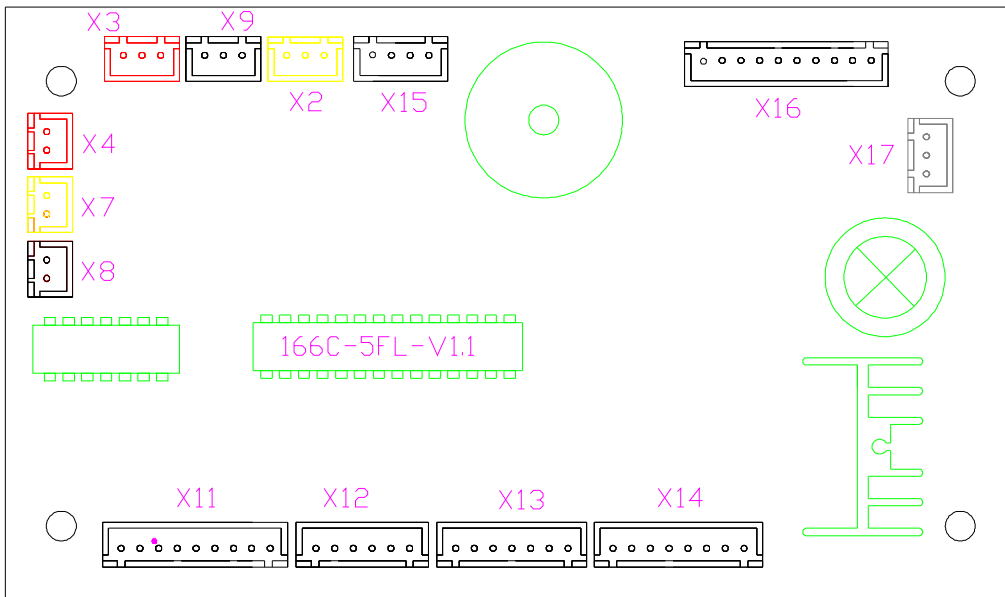

Fig. 10

- X2: To upper fan(yellow)
- X3: To lower fan(red)
- X4: To lower sensor(red)
- X7: To upper sensor(yellow)
- X8: To middle sensor(white)
- X9: To middle fan(white)
- X11: To lower display PCB(X301)
- X12: To lower display PCB(X302)
- X13: To upper display PCB(X201)
- X14: To upper display PCB(X202)
- X15: To LED light(white)
- X16: To power PCB
- X17: To lower heater fan(black)

○ Layout of power PCB ( Fig. 11)

- |                            |                             |
|----------------------------|-----------------------------|
| 1.To transformer primary-L | 2.To power-L                |
| 3.To power-N               | 4.To transformer primary-N  |
| 5.To PTC heater            | 6.To compressor             |
| 7.To valve                 | 8.To main PCB (white)       |
| 9.To condensor fan(red)    | 10.To transformer secondary |

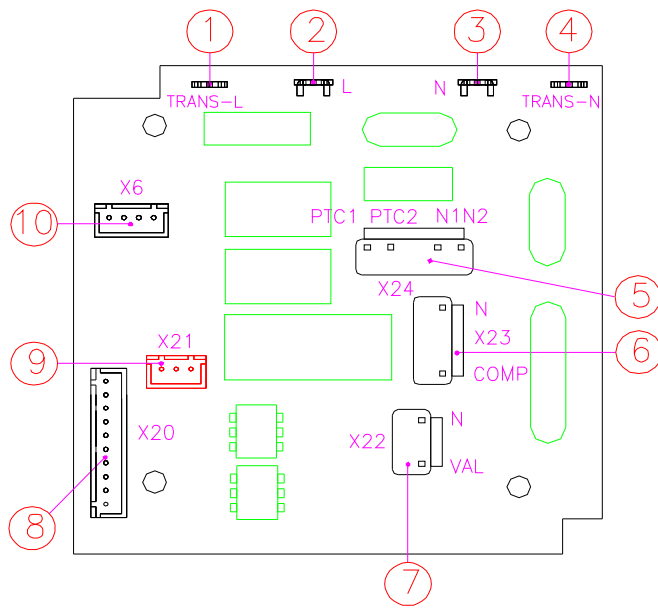
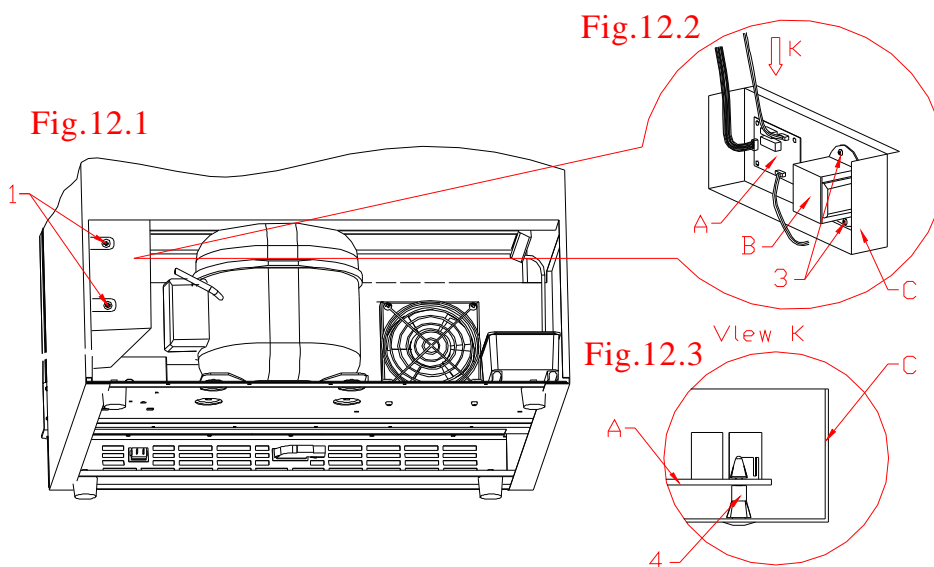

Fig. 11

○ How to remove the power PCB and transformer

- 1 >. Remove 2 fixing screws(1) of the electrical box;( Fig.12.1)
- 2 >. Take apart the electrical box( Fig.12.2)
- 3 >. Disconnect all connectors, pinch the plastic nails(4), pull up the PCB(A), take apart the PCB, replace it please.( Fig.12.3) (Vlew K)
- 4 >. Connect all connectors, ( Fig.11)
- 5 >. Remove 2 fixing screws(B) of the transformer(3), disconnect the connectors, and replace it.( Fig.12.2)



○ How to replace the LED light

1. How to replace the upper LED light ( Fig.13)

- 1 >, Take away the upper zone shelves;(→3) ( Fig.1& Fig.1.1 )
- 2 >, Remove 2 fixing screws(7) of the light cover(B), take apart the cover.( Fig.13)

3>, Remove the fixing screws of the LED light PCB(B),disconnect the connector(E),replace the light PCB please.

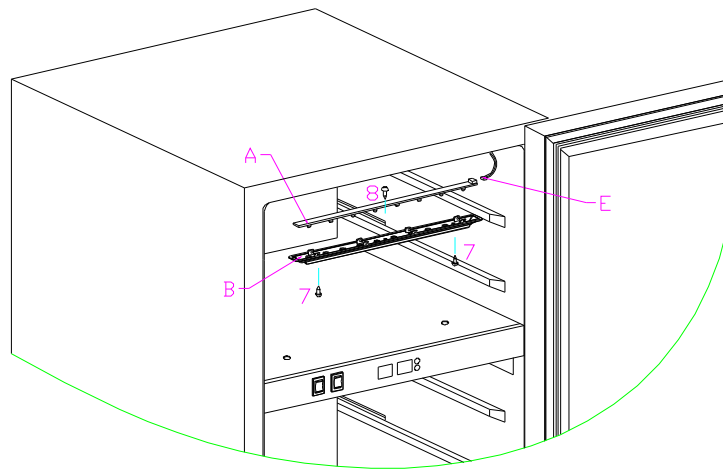

Fig. 13

2. How to replace middle and lower LED light:(Fig.14)

1>, Take apart the shelves(→3) (Fig.1& Fig.1.1 )

2>, Disconnect the upper cover of the middle airduct board.(→3) (Fig.2.1)

3>, Disconnect the connector(C),pinch the head of the plastic nail,pull up the display,take the PCB away from nail one by one,and take apart the light PCB,replace it.( Fig.14)

Notice:it is not need to take the lower cover of the airduct board.

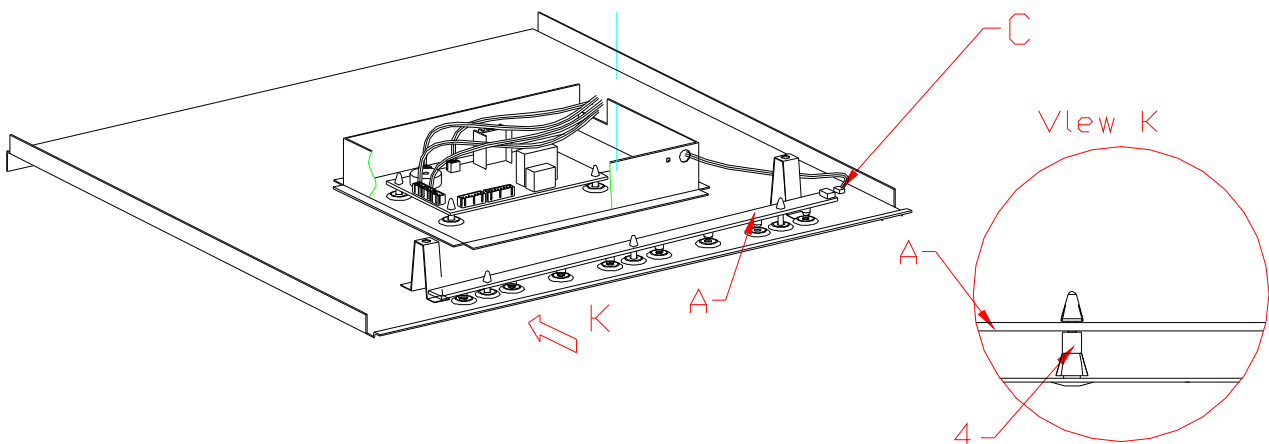

Fig. 14

▲ The heater default

○ How to diagnose the default

If the temperature of refrigeration compartment is (-2°C) lower than setting temperature for an empty unit (assuming ambient temp of over 0 degrees centigrade and continuous operation and normal temperature of the refrigerating compartment), check the heater fan and PTC heater. If both are working normally, there is probably a heating system fault.

○ How to repair the fault:

1. How to check the heater fan.

If the temperature of refrigeration compartment is lower than set temperature but heater fan does not function, after verifying no bad connections replace the fan unit .

2. How to check the PTC heater

Check the resistance at both sides of PTC heater using a Multi meter; the reading should be approx 1.5 KΩ (assuming normal temperature), if open circuits Replace the PTC heater having once verified the connections to the PTC heater. replace new one.See (Fig.19).

3. If no fault in the fan or PTC heater, replace the control panel, see (Page 20-23).

○ How to replace the PTC heater

- 1>. Take away the shelves(→3) (Fig.1& Fig.1.1 )
- 2>. Take apart the airduct board(→3 ) (Fig.2.1 & Fig.2.2 & Fig.2.3 )
- 3>. Remove the fixing screws of heater,replace it. (Fig.15)

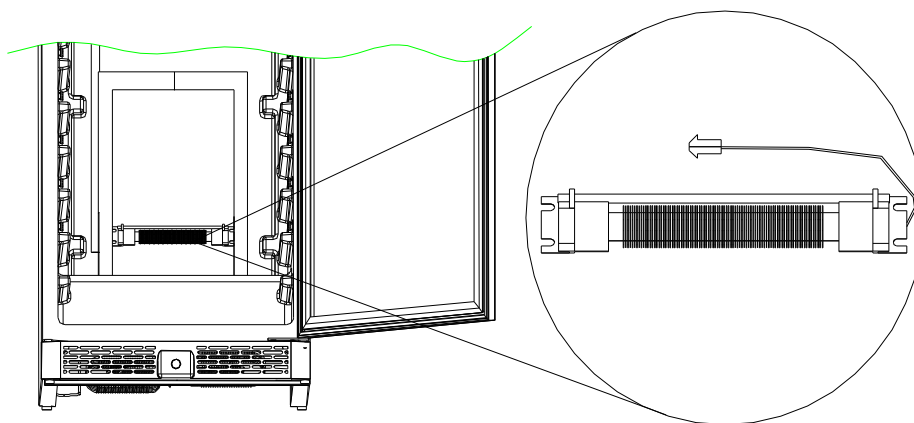

Fig. 15

- 4 .If it is PCB broken,replace it please. (Fig. 9)