



WF1101

Caple Wine cellar
154 bottles 2 zone, black grill



INSTRUCTION MANUAL

Thank you for buying your new CAPLE Wine Cabinet. To ensure that you get the best results from your new purchase, we strongly suggest that you read this instruction manual thoroughly before use. This manual contains installation advice, usage instructions and other important facts about your CAPLE Wine Cabinet. If treated with care, your CAPLE Wine Cabinet should give you many years of trouble-free use.

IMPORTANT WARNINGS AND ADVICE

- Unpack your wine cabinet carefully and remove all of the protective packing from inside and outside.
- Packing (plastic bags, polystyrene, nails, metal, etc.) must not be left within the reach of children as they are a potential source of danger.
- After unpacking, make sure that the appliance is in perfect order. If you have any doubt, do not use it and contact your retailer.
- Check that all the fittings are in the correct position on the inside of the cabinet.
- Release the mains lead which is fitted with a 13 amp UK type plug.
- Move your wine cabinet to its final location.
- **DO NOT MOVE YOUR CABINET WHILE LOADED WITH WINE** as this could distort the cabinet.
- Ensure that the specified ventilation instructions are adhered to.
- Do not try to modify the appliance's technical characteristics as this could be dangerous
- This appliance should only be used for the specific purpose for which it was designed, i.e. storage of wine. It is not designed for food storage.
- Do not clean or maintain the appliance without disconnecting it first.
- To prevent damaging the door gasket, make sure that the door is fully open when pulling shelves out.
- Ensure that you fully understand these instructions before operating this appliance.
- Caple are NOT responsible for: -
 1. Damage caused by incorrect, mistaken or irrational use.
 2. For any errors in this manual, or for any damage linked to or following the provision, performance or use of any wine cabinet.
- The information in this document is subject to modification without prior notice.

DISPOSAL OF OLD APPLIANCE

Discarded appliances are potentially dangerous to CHILDREN.

Before you throw away your old Wine Cabinet:

- **Remove the door. Leave the shelves in place so that children cannot easily climb inside.**
- **Never allow children to operate, play with, or climb inside the appliance.**

INSTALLATION INSTRUCTIONS

BEFORE TURNING THE WINE CABINET ON ENSURE IT IS PERFECTLY LEVEL. This will minimise any vibrations.

Your cabinet is equipped with 4 adjustable feet. However, we recommend that you tighten the back feet to the maximum and then use the front feet to level the cabinet.

IMPORTANT: WAIT 2 HOURS BEFORE TURNING THE WINE CABINET ON FOR THE FIRST TIME.

Safety Instructions

- A fan evacuates heat via the bottom vents.
- It must be installed well away from any heat source.
- It must not be placed in direct sun light.
- It must not be in a damp location (laundry, pantry, bathroom, etc)
- It must be perfectly level.
- It must have a correctly installed and reliable electricity supply correctly earthed.
- Use of a multi-socket or extension lead is not recommended.
- This wine cabinet must be earthed to provide protection in the event of an electrical short circuit.
- It is fitted with a power cord having an earth wire terminating in a 13amp plug.
- Consult a qualified electrician or service engineer if the earthing instructions are not completely understood.

WARNING: INCORRECT EARTHING CAN RESULT IN THE RISK OF ELECTRIC SHOCK.

OPERATING INSTRUCTIONS

The wine cabinet should be placed where the ambient temperature is between 0-35 deg centigrade (32-95 degrees Fahrenheit). If the ambient temperature is above or below this range, the performance of the unit may be affected. For example, placing your unit in extreme cold or hot conditions may cause interior temperatures to fluctuate. The range of 5-18 °C (40-65 degrees Fahrenheit) may not be reached.

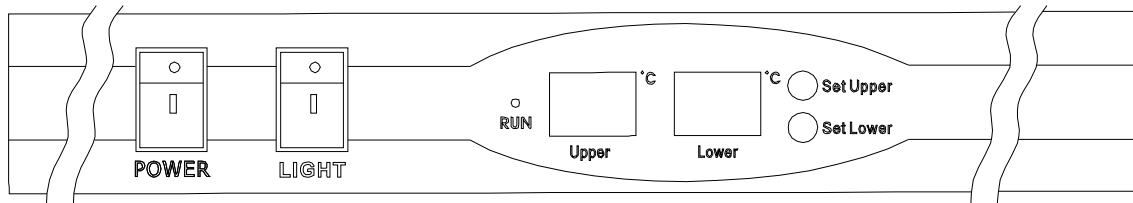

- **RUN**
Indicator light illuminates to signify the cooling mode is currently in operation.
- **Light**
To control the inner light turn on/off.
- **Power**
To control this appliance turn on/off.
- **“Set Upper” Button**
Used to raise(warm) the temperature in the top zone.
- **“Set Lower” Button**
Used to lower(cool) the temperature in the bottom zone.
- **“Upper”**
To show the temperature of the top zone.
- **“Lower ”**
To show the temperature of the bottom zone.

Setting the Temperature Control

- Each compartment of the wine cabinet (upper & lower) is independently controlled. To set the temperature:
Connect the power cord to a properly grounded outlet. In the event of a power interruption, all previous temperature settings are automatically erased and each compartment will default to a preset temperature setting of: 7°C for upper zone and 12°C for lower zone.
Set the desired cooling temperature by pressing the buttons adjacent to the “set upper/set lower” program. Each depression of the buttons will scroll through the available temperature settings (for each compartment) in increments of 1 degree. The temperature selected will flash in the LED display for approximately 5 seconds, then revert back to display the temperature of the internal cabinet

Upper compartment: The temperature setting can be adjusted from 5°C to 18°C.

Lower compartment: The temperature setting can be adjusted from 5°C to 18°C.

- To view the “set” temperature at any time, press and hold the corresponding button for approximately 5 seconds, the “set” temperature will temporarily “flash” in the LED display for 5 seconds.

Door Lock

The door lock keys are located inside the plastic bag that contains the User's Guide. Insert the key into the lock and turn it counterclockwise to unlock the door. To lock the door do the reverse operation making sure metal pin is engaged completely. Remove the key and place it in a secure place for safekeeping.

Installation of Shelves

First pull the shelf out to its limit, then lift the edge of the shelf upward and pull the shelf out of the cabinet. Reverse this operation to install the shelf. (Note: you should first insert the right side of the shelf into the rail compartment.)

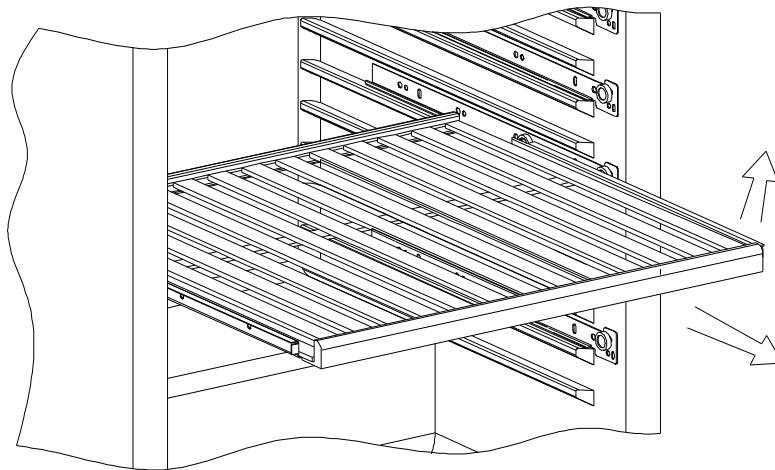

NOTE:

If the unit is unplugged, if power is lost, or turned-off, you must wait 3 to 5 minutes before restarting the unit. If you attempt to restart before this time delay, the wine cabinet will not start.

When you use the wine cabinet for the first time or restart the wine cabinet after it has been switched off for a long time, there could be a few degrees variance between the temperature you select and the one indicated on the LED readout. This is normal and it is due to the length of the activation time. Once the wine cabinet has been running for a few hours, the temperature display will re-gain accuracy.

DEFROSTING/CONDENSATION

Your wine cabinet is designed with an "Auto-cycle" defrost system. When the RUN cycle is OFF, the refrigerated surface of the wine cabinet (interior rear wall) defrosts automatically. The defrost water is channeled into a drain pan which is located at the back of the wine cabinet next to the compressor from where it evaporates.

HUMIDITY MAINTENANCE SYSTEM

The wine cabinet is equipped with a system for maintaining the correct level of humidity. If humidity is too low, insert the small plastic reservoir on to the top shelf. Fill this reservoir 3/4 full with water. Check the water level occasionally and refill as necessary.

CARE AND MAINTENANCE

Cleaning

- Turn off the power, unplug the appliance, and remove all items including shelves and rack.
- Wash the inside surfaces with a warm water and baking soda solution. The solution should be about two tablespoons of baking soda to one litre of water.
- Wash the shelves with a mild detergent solution.
- Wring excess water out of the sponge or cloth when cleaning the control panel, or any electrical parts.
- Wash the outside cabinet with warm water and mild liquid detergent. Rinse well and wipe dry with a clean soft cloth.

Power Failure

- Most power failures are corrected within a few hours and should not affect the temperature of your appliance if you minimise the number of times the door is opened. If the power is going to be off for a longer period of time, you need to take action to protect the contents.

Vacation Time

- **Short vacations:** Leave the wine cabinet operating during vacations of less than three weeks.
- **Long vacations:** If the wine cabinet will not be used for several months, remove all items and disconnect. Clean and dry the interior thoroughly. To prevent odour and mould growth, leave the door open slightly (blocking it open if necessary).

Moving Your Wine Cabinet

- Remove all bottles.
- Securely tape down all shelves inside the cabinet.
- Turn the adjustable legs up to the base to avoid damage.
- Tape the door shut.
- Be sure the appliance stays secure and upright during transportation. Also protect the outside of the wine cabinet. (e.g. with a blanket).

Energy Saving Tips

- The wine cabinet should be located in the coolest area of a room, away from heat producing appliances, and out of the direct sunlight.

TROUBLE SHOOTING GUIDE

You can solve many common wine cabinet problems easily, saving you the cost of a possible service call. Try the suggestions below to see if you can solve the problem before calling the service engineer.

PROBLEM	POSSIBLE CAUSE
The wine cabinet does not operate.	The appliance is not plugged in. The appliance is turned off. The circuit breaker has tripped or a fuse has blown.
The wine cabinet is not cold enough.	Check the temperature control setting. The external environment may require a higher setting. The door has been opened too often. The door is not closed completely. The door gasket does not seal properly.
The wine cabinet turns on and off frequently.	The room temperature is hotter than normal. A large amount of bottles have been added to the wine cabinet. The door has been opened too often. The door is not closed completely. The temperature control is not set correctly. The door gasket does not seal properly.
The light does not work.	The appliance is not plugged in. Not plugged in. The circuit breaker has tripped or a fuse has blown. The bulb needs replacing. The light button is "OFF".
The wine cabinet vibrates	Check that the wine cabinet is level.
The wine cabinet seems to make too much noise.	The rattling noise may come from the flow of refrigerant, which is normal. As each cycle ends, you may hear gurgling sounds caused by the flow of refrigerant. Contraction and expansion of the inside walls may cause popping and crackling noises. The wine cabinet is not level.
The door will not close properly.	The wine cabinet is not level. The door was reversed and not properly installed. The gasket is dirty. The shelves are out of position.

RECOMMENDED TEMPERATURE SETTINGS

For keeping ALL TYPES OF WINES

12 °c to 14 °c

Champagne NV, Sparkling	6 °c
Champagne Vintage	10 °c
Dry White Semillon, Sauvignon Blanc	8 °c
Dry White Gewurstraminer, Riesling	10 °c
Dry White Chardonnay	10 °c
Vintage chardonnay	14 °c
Sweet White Sauternes Monbazillac, Late Harvest ice wine	10 °c
Sweet whites vintage Sauternes	14 °c
Beaujolais	13 °c
Red Pinot Noir	16 °c
Vintage Pinot noir red	18 °c
Red Cabernet, Merlot, French, Australian, New Zealand, Chilean, Argentinean, Italian, Spanish, Californian	18 °c
Red Grenache, Syrah	16 °c