



WF1104

Caple Free Standing wine cabinet



Technical information

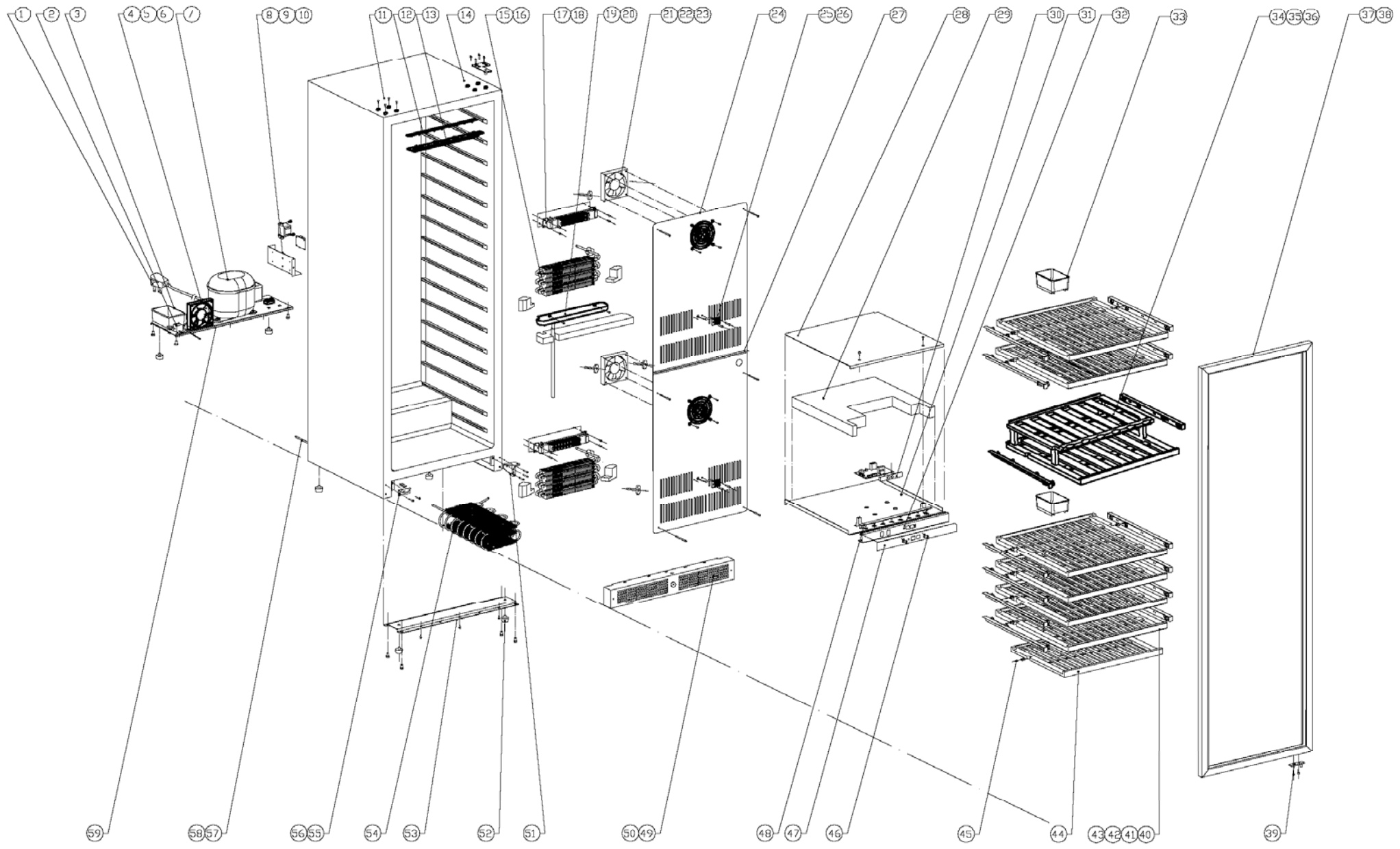

WF1104

Caple Free Standing wine cabinet

8 | 7 | 6 | 5 | 4 | 3 | 2 | 1

D
C
B
A



WF1104 - Caple Free Standing wine cabinet

Item	Part Code	Description	Qty
1	DG2-14	Power cord	1
2	DG12-37.1	Refrigerant valve	1
3	DG13-1	Water tank	1
4	DG17-145-2	Condenser fan	1
	DG7-3.2-BH		
5	DG14-56	Fan bracket	2
6	DG19-3	Fan cover	1
7	DG1-88	Compressor	1
8	DG22-302	Electrical box cover	1
9	DG3-77.6	PCB board	1
10	DG6-19	Transformer	1
	BZ5-120	Transformer label	1
11	DG13-8	Decorative nail	4
12	DG3-13-W	LED light	1
13	DG13-129	LED Light Cover	1
14	DG14-160-SR	Top right hinge module	1
15	DG12-50	Evaporator	2
16	DG18-63	Foam	4
17	DG11-1	Heater	2
18	DG14-24	heat insulation panel	2
19	DG13-10	Water box	1
20	DG18-59	Foam	1
21	DG7-3.2-BH	Evaporator fan(Upper)	1
	DG17-143	Fan wire	1
22	DG7-3.2-BH	Evaporator fan(Upper)	1
	DG17-144-1	Fan wire	1
23	DG19-6	Fan cover	2
24	DG22-283	Air duct board	1
25	DG8-21-1	Senser	1
26	DG8-21	Senser	1
27	DG13-193	Support bracket of middle aire duct board	1
28	DG22-234	Upper panel of middle airway-board	1
29	DG18-60	Foam	1
30	DG13-32-1	Displayer holder	1
31	DG22-233	Lower panel middle airway-board	1



WF1104 - Caple Free Standing wine cabinet

Item	Part Code	Description	Qty
32	DG13-194	Display support	1
33	DG13-1.1	Humid box	2
34	DG15-156	two-double Wooden shelves	1
	DG15-138	Stainless Steel Trim	1
35	DG13-253-1R	Track Right	1
36	DG13-253-1L	Track Left	1
37	DG23-205	Door	1
38	DG13-3034	Lock hole cover	1
39	DG14-169-SR	Door axis	1
40	DG15-155	Wooden shelves E1	6
	DG15-138	Stainless Steel Trim	6
41	DG13-253-R	Track Right	6
42	DG13-253-L	Track Left	6
43	DG13-274	Wooden shelf sliding plate	14
44	DG15-1002.2	Wooden shelves WE-2	1
	DG15-106	Stainless Steel Trim,For shelf WE-2	1
45	DG13-7	Shelf stopper	16
46	DG13-130-S	button	4
47	DG20-285	Display panel	1
48	DG3-18-W	LED light	1
49	DG22-3103-S	Bottom grill	1
50	DG14-140	Lock Assembly	1
51	DG14-170-SR	Lower hinge module right	1
52	DG13-6-16	Cabinet leg, type BC50	4
53	DG22-240	Support bracket of front legs	1
54	DG12-3	Condenser	1
55	DG14-170-SL	Lower hinge module left	1
56	DG13-366-B	Door support	1
57	DG12-111	Air-circulating pipe (Lower)	1
58	DG12-110-2	Air-circulating pipe (UPPER)	1
59	DG22-239	Compressor bracket	1



WF1104

Caple Free Standing wine cabinet

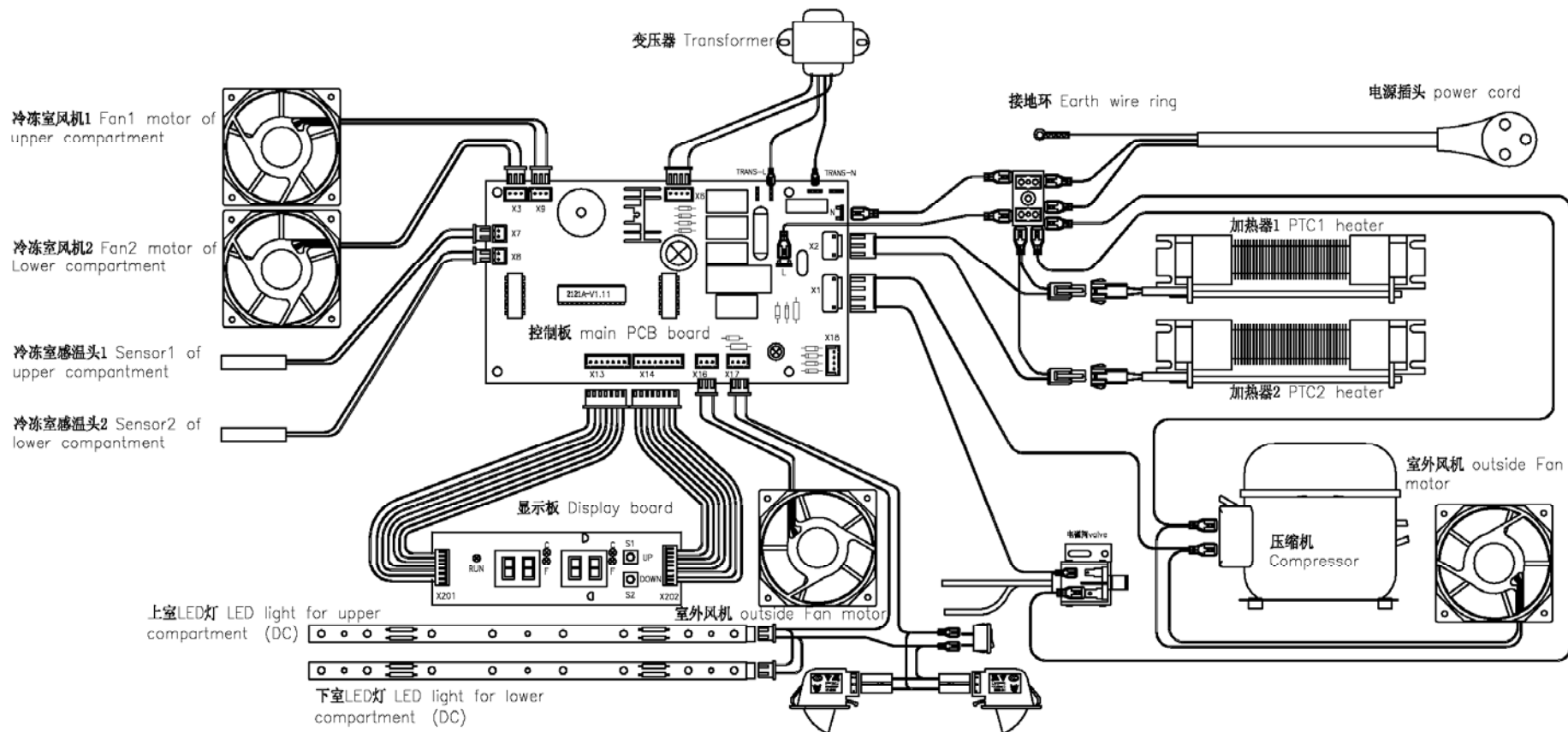

Computer Controlled Single Temperature and Synchronous Dual Temperature Wine Cellar

WF1544 WF1104

Service Manual

Here below we listed various faults while using the wine cellar, and the method of check-up and solve these default, and find the information of the correspondent page

Statement : (Fig.4) shows the reference figure Fig4

(→6) shows the reference page 6

Warning: before attempting any cleaning or maintenance this unit MUST be disconnected from the electrical supply, to prevent electrical shock

▲Preparation before maintenance

○Equipment

- | | |
|---|---------------------------------------|
| 1 . Pliers | 2 . Set of Phillips head screwdrivers |
| 3 . Seal pliers | 4 . Electrical Multi meter |
| 5 . Amp meter (5A) (caliper cable type) | 6 . Electrical soldering iron |
| 7 . Wire strippers | 8 . Seal pliers |

○Equipment

- | | | |
|-----------------|-------------------------------------|----------------------|
| 1 . Vacuum pump | 2 . Soldering iron for copper pipes | 3. Refrigerant meter |
|-----------------|-------------------------------------|----------------------|

▲ Difference

- WF1544 character..... (→3)
- WF1104 character..... (→3)
- JG165BSS character..... (→3)

▲ Cooling system fault

- How to Evaluate the fault.....(→3)
- How to maintain the fault(→4)
- How to remove the air duct board(→5)
- Diagram showing the front side soldered joints.....(→6)
- Diagram showing the rear side soldered joints(→7)

▲ Noise problems

- Compressor noise(→8)
- Fan noise(→7)
- Refrigerant jet noise.....(→10)
- Capillary vibration noise(→10)
- Oil jam noise.....(→10)

▲ Evaporator freezing(→11)

▲ The instability of the wine cellar temperature(→11)

▲ Control system problems

- Fault finding by the self-check mode.....(→11)
- Fault particular happen on Synchronous Dual Temperature Wine Cellar.....(→11)
- Sensor fault.....(→12)
- How to replace the sensor.....(→13)
- Refrigerant Valve fault.....(→13)
- LED display fault.....(→14)
- How to remove electrical box and parts inside of electrical box(→14)

- The name and explanation of the PCB board connectors(→16)
- Diagram show power PCB.....(→17)
- How to remove power PCB board and the transformer.....(→17)
- How to replace the switch.....(→18)
- How to replace the Led light.....(→19)

▲ Heating system problems

- How to evaluate the fault.....(→20)
- How to maintain the fault.....(→20)
- How to replace the PTC heater.....(→20)

△ Difference

○WF1544 character :

1. There is an evaporator in single temperature wine cellar. But it can add a PTC heater & anti-frost protector according to client requirements.

2. There are two kinds of fan location

1>. One is the fan fitted at top of air-duct board

2>. Another is the fan fitted at rear of air-duct board

3. There are two kinds of PCB board.

1>. One is only the main PCB board fitted in electrical box with transformer.

2>. Another includes two parts –

power PCB board which is fitted in compressor compartment with transformer & main PCB board which is fitted in electrical box.

○WF1104 character :

1.1>. Normal dual temperature wine cellar (5°C-10°C

for upper compartment/10°C-18°C

for lower compartment

& 5°C-12°C

for upper compartment/12°C-18°C

for lower compartment) include 1 evaporator, 1 PTC heater, not refrigerant valve.

2>. Synchronous dual temperature wine cellar (5°C-18°C for both compartments) include 2 evaporators, 2 PTC heaters, 1 refrigerant valve.

2. There are two kinds of PCB board.

1>. One is only the main PCB board fitted in electrical box with transformer.

2>. Another includes two parts –

power PCB board which is fitted in compressor compartment with transformer & main PCB board which is fitted in electrical box.

○ JG165B

JG165B character :

1. It includes 2 evaporators, 2 PTC heaters, 1 refrigerant valve

2. PCB board includes two parts –

power PCB board which fitted in compressor compartment with transformer & main PCB board which fitted in electrical box.

△ Cooling system faults

- How to diagnose faults:

It should take approximate 3 hours to reach the lowest setting temperature for an empty unit of both compartments (assuming ambient temp of 32 degrees centigrade and continuous operation). If not, check the compressor, cooling fans, controller, and sensors. If all these are working normally, there is probably a cooling pipe fault.

- Maintain the faults :

1. Check the compressor

If two zones can not refrigerate, check the rated current of the compressor with a caliper type Amp meter, and the current should be within 0.8 to 2 Amps. If the current not in this range, turn off and cut off the pipes (Fig.5 and Fig.5.1, see point D & Fig.5 and Fig.5.1, see point A) from the compressor. Then turn on the unit and check there is electricity current flowing to the compressor, and check if there is pressure at the outlet pipe, If the current reading is still out of range specified above or no pressure from the compressor outlet, replace the whole compressor. (Noted: Turn on the compressor which cut pipe not longer than 15 minutes in order to avoid suck moist air)

2. check the cooling system pipe work

2.1>. Under the condition of the compressor normally running situation, the two zones do not refrigerate, and it is possibly the refrigeration system leak. The maintain procedure is following.

a. Cut off discharge pipe from compressor and charge with refrigerant to 0.8—1Mpa nitrogen via the process pipe. Then place your hand close to the broken end of discharge pipe, if you can feel a little airflow, this proves the capillary is normal, if not it means the capillary is jammed. (Noted: There are two capillaries in synchronous dual temperature wine cellar. If the flowing direction of refrigerant valve is not changed, you can feel a little airflow from only one of capillary, if not, please change the flowing direction of refrigerant valve. See Page 12)

b. Weld the broken discharge pipe if capillary works normal, then charge to 0.8—1Mpa nitrogen via the process pipe and check if there are any leaks from every soldered joint of the cooling system using soapy water and looking for tiny bubbles, Check the soldered joints around the compressor first (Fig.5 & Fig.5.1), then check the soldered joints around the evaporator see (Fig.3). Remove the air duct board when you check the evaporator joints, see (Fig.1&Fig.2).

c. If there are no leaks as the b item. The faults maybe :

①A leak in the condenser or anti-dew pipe. This internal leaks cannot be repaired, and it can be replaced with the new one of the same module.

②Or a fault of other components in the unit, please replace the same module.

d.. If there are no leaks in the cooling system pipe work, please refill refrigerant

2.>.When the compressor work normally, one zone did not refrigerate, the fault is due to the component of one

zone. The maintain procedure is as following (The structure of two zone is the same, and here we only recommend one method).

- a. Check the refrigerant valve, and check the voice. Turn off the power, exchange two poles of the refrigerant valve, then turn on the power, and listen that it will move with a snip-snap, otherwise it is out of power or the refrigerant valve is fault.. Confirm that the circuit board is normal, and replace the same module's refrigerant valve. (→12) (Fig.9)
- b. If the refrigerant valve work normally, the fault capillary may jammed. The examination method is as above.
- c. Replace the fault spare parts. Confirming the cooling system is not jammed, refill the refrigerant.

3. Refill the refrigerant:

1>. Using the vacuum pump from a vacuum in the system, via the joint of the low-pressure pipe which on the process pipe of compressor (→5、 →6) (Fig.5, Fig.5.1 showing A), the high-pressure pipeline which on the process pipe of the drain filter (Fig.5, Fig.5.1 showing G). Apply the vacuum pump for approximately 20 minutes. Until the vacuum is lower than 100Pa. Then solder the drainpipe. Keep the vacuum running while soldering this joint

2>. Fill Cooling system with refrigerant via the process pipe (→5、 →6) (Fig.5, Fig.5.1 showing A). (The refrigerant is R134a. Regarding refrigerant quantity, please refer to the instruction at back label of wine cellar). Then solder the compressor process pipe after the system is charged with refrigerant.

4. Running test.

Fit all the components after the above procedures and turn the unit on. To verify the effectiveness of the repair, monitor the unit the compressor should automatically stop within + or - 2.5 deg centigrade of the set temperature within approx 3 hours (assuming an ambient temperature of 32°C and the unit is empty)

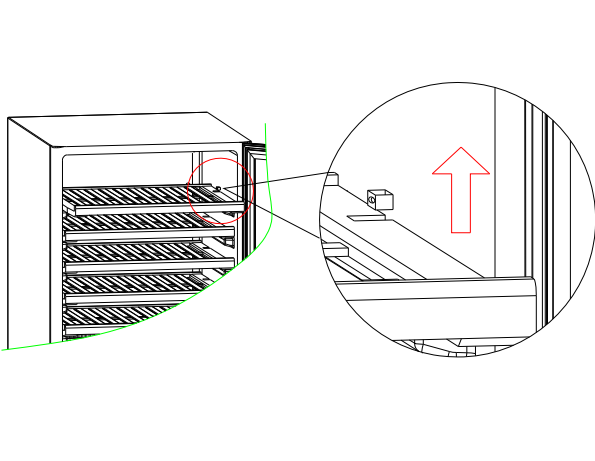

Fig. 1

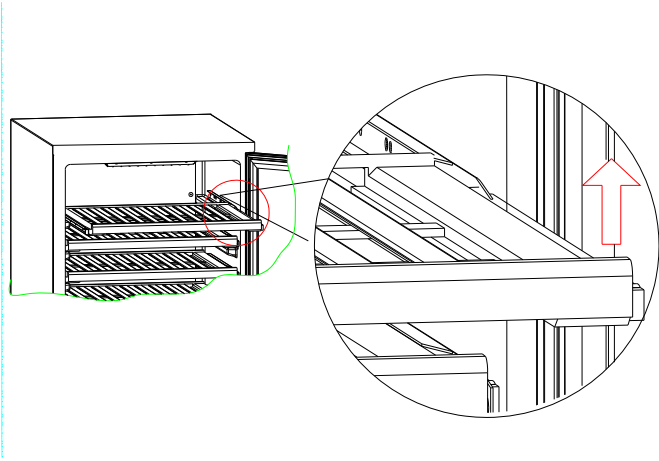

Fig. 1.1

○ How to remove the air duct board

1. Take out the shelves before remove the air duct board. Normally there are three way to fix the shelf.

1> Fixing block installation

Flatly pull the shelf to the corresponding indentation, and then upper the shelf and drag out of it (Fig.1)

2> Side rail installation

Flatly draw off the shelf to the end, then raise upper the shelf and drag it out.(Fig.1.1)

3> Low rail installation

As same as fixing block installation (Fig.1)

2. There are three kinds of air duct board

1> For normal dual temperature model

a. Remove the screw (1) of top middle air duct board cover (A) and take the cover (A) out (Fig.2.1)

b. Unplug all the connectors of PCB board, except transformer and display panel, then remove 4 screws (2) on low air duct board and take it out carefully (Fig.2.2).

Fig:2.1

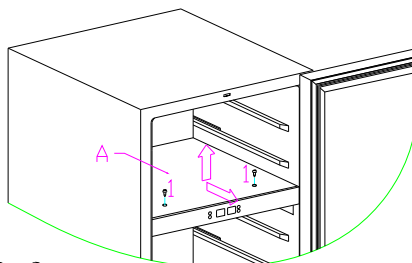

Fig:2.2

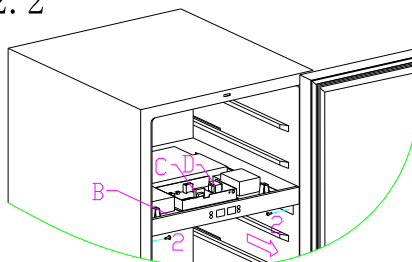
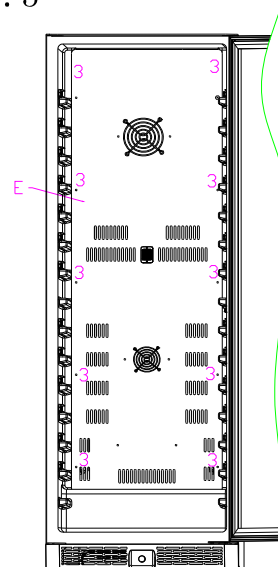

Fig:2.3



c. Remove 10 screws (3), unplug fan and sensor's connectors, then take out air duct board (E) (Fig.2.3)

d. Here is appearance after removed air duct board.(Fig.3)

Please be noted that the evaporator in upper compartment is as same as the one in lower compartment. (Fig.3)

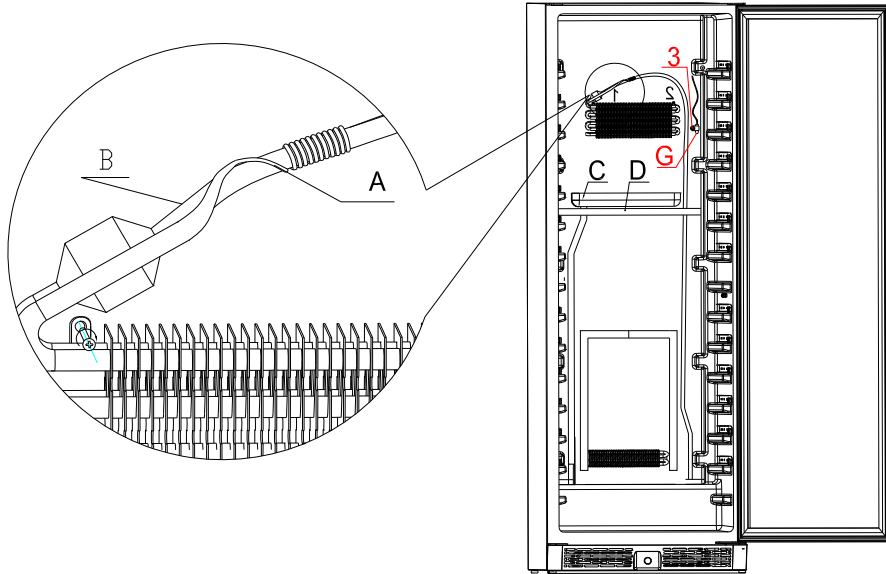

Fig. 3

- 2>. The Synchronous Dual Temperature air duct board's teardown way is as same as normal dual temperature model
- 3>. For single temperature model which the evaporator's fan and PTC heater's fan is fitted at rear of air duct board.
 - a. Remove 10 screws (3), unplug fan and sensor's connectors, then take out air duct board (E) (Fig.2.3)
- 4>. For single temperature model which the evaporator's fan and PTC heater's fan fitted at top of inner
 - a. Remove 5 screws (1) (Fig.4), then take out the electrical box (Fig.4.1). Mark relevant note on PCB board connector to avoid any mistake when installed, then unplug all the connector on PCB board.
 - b. Remove 6 screws (2) (Fig.4), then take out top air duct board (Fig.4.1).

Fig. 4

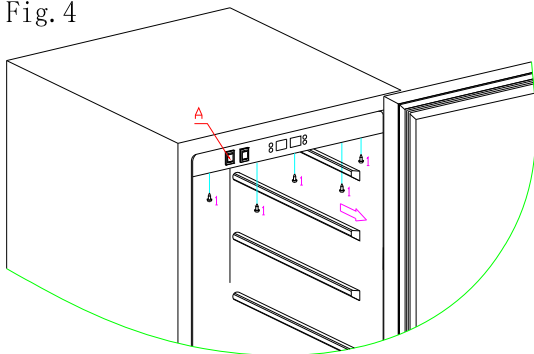

Fig. 4. 2

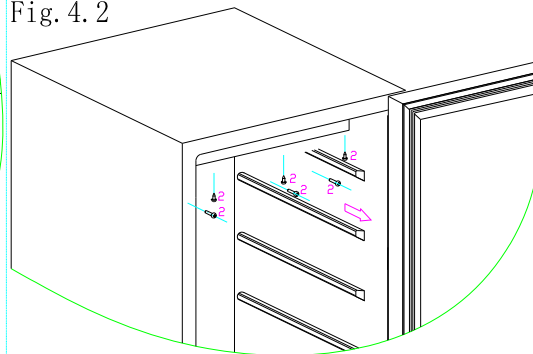

Fig. 4. 1

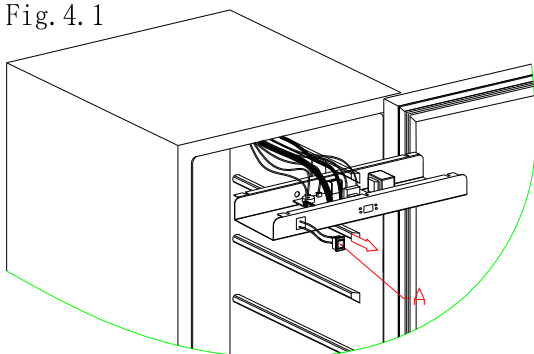
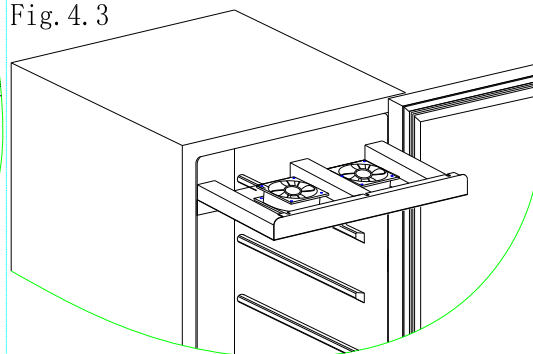

Fig. 4. 3



○ Front solder conjunction distribution diagram (→5) (Fig.3)

A: Capillary solder conjunction B: Evaporator solder conjunction C: Water tank D Foam of middle air duct board

○ Back solder conjunction distribution diagram

The wine cellar with refrigerant valve (→6) (Fig.5)

The wine cellar without refrigerant valve (→7) (Fig.5.1)

A: Process pipe solder conjunction B: Dew clearance pipe solder conjunction

C: Lower compartment's circulating pipe solder conjunction

D: Discharge pipe solder conjunction E: Upper compartment's circulating pipe solder conjunction

F: Condenser solder conjunction G: Dry filter seal pipe solder conjunction

H: Lower compartment's capillary solder conjunction I: Connecting pipe solder conjunction

J: Refrigerant valve solder conjunction K: Upper compartment's capillary solder conjunction

1. This is the wine cellar with refrigerant valve's back solder conjunction distribution diagram

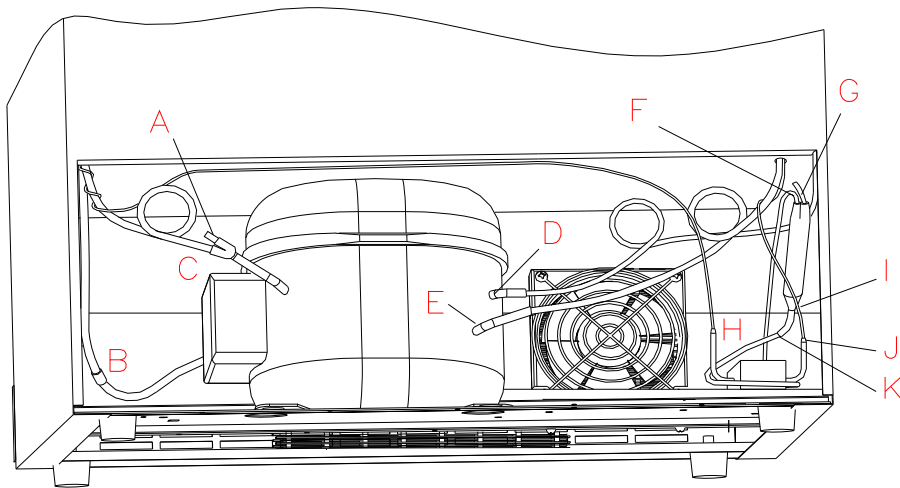

Fig. 5

2. This is the wine cellar without refrigerant valve's back solder conjunction distribution diagram

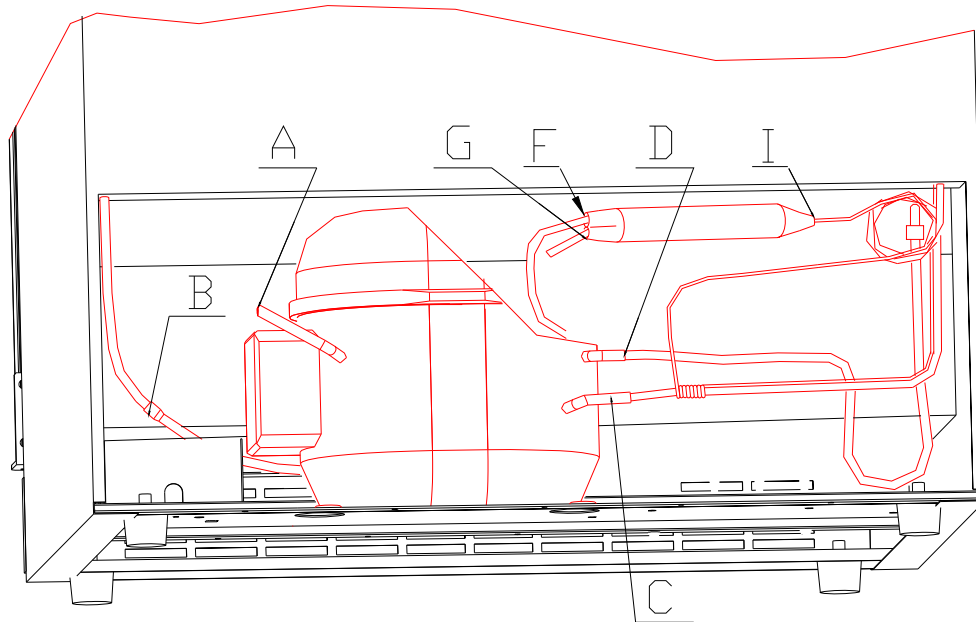

Fig.5.1

▲ Noise problems

○ Compressor noise

1. The working of motor and piston motion will cause noise when compressor working. So if noise is steady and not exceeds 42 dB, it's normal. If noise is not steady or very high, it's compressor fault and it should be maintained or replaced.
2. If compressor's shock absorption rubber is hardening or damaged, or fixing screw of compressor is too tight or loose, it will cause noise. The settlement is to change new shock absorption rubber or adjust fixing screws.

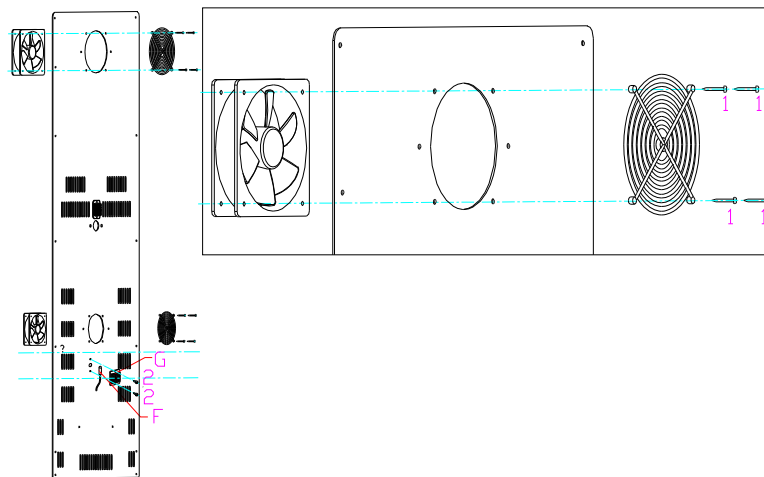

Fig. 6

○ Fan noise

1. When the fans are running , the vanes are circumrotating rapidly and the air flows, which will cause steady and standard noise. The noise should not exceed 32dB and it is normal.
2. If the noise is extremely high and abnormal, the cause maybe as below
 - 1>. The axis of the fan is broken
 - 2>. The fan is broken and lost balance
3. If the fan is broken, please replace the same specification's one. According difference model, there are three kinds of fan
 - 1>. For Synchronous Dual Temperature wine cellar (Note: the way to replace upper compartment's fan is as same as lower compartment's fan)

a. Remove the shelves. (→3) (Fig.1 & Fig.1.1)

b. Remove the air duct board (→5) (Fig.2.1 & Fig.2.2 & Fig.2.3)

c. Remove 4 screws (1), then replace the fan. (Fig.6)

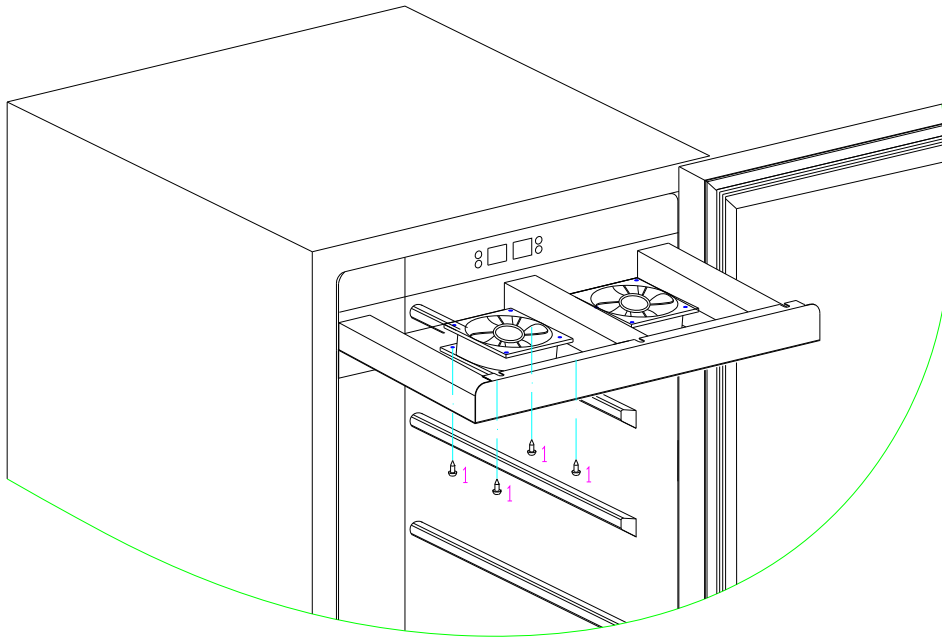

Fig. 6.1

3>. For normal two temperature wine cellar

The way to replace fan after air duct board is as same as synchronous dual temperature wine cellar (→6) (Fig.6)

Below is how to replace the fan in middle air duct board.

a. Remove the shelves (→3) (Fig.1 & Fig.1.1)

b. Remove 8 screws (1), then take out fan cover (Fig.6.2) . Remove 3 screws (2), then take out lower middle air duct board

& unplug fan's connector, replace the fan (Fig.6.3)

4>. How to replace condenser fan.

a. Remove snap rings (A), take out compressor electrical's cover (→9) (Fig.7)

b. Mark relevant note on connector (C & D), then unplug them (→9) (Fig.7)

c. Move the upper body backwards and down 45°

or put it on table and let the compressor support bracket suspend.

Remove 2 screws (1 & 2), then replace the fan (→9) (Fig.7 & Fig.7.1)

(Note: For the model with separated PCB board, the fan's connect is on power PCB board. Please refer to how to remove power PCB board and transformer, remove PCB board cover first, then unplug fan's connector, replace the fan (→15)

(Fig.13)

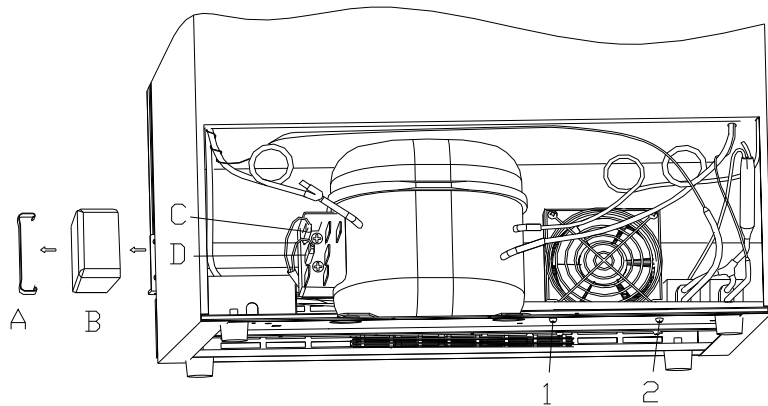

Fig. 7

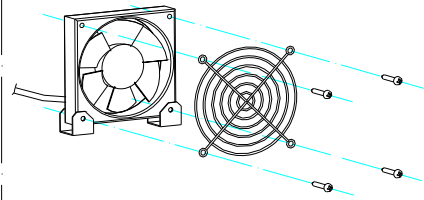

Fig. 7.1

○ Refrigerant jet noise

Default: It is continuous noise like a water spray from the capillary.

Reason: The end of the capillary is in the wrong position, or there are rough edges on the end of the capillary.

Solution:

- 1>. Heat the soldered joint of the capillary (→5) (Fig.3, A) , then remove the capillary from the evaporator and smooth the end with rasp. (Caution: do not allow any particles into capillary)
- 2>. Insert the capillary into the evaporator, then solder it back into the correct position (not exceeding 15mm in the evaporator) and pack the joint with anti vibration compound
- 3>. Refill with refrigerant. (→4)

○ Capillary vibration noise

Default: High frequency impact noise in capillary.

Caused by either reason below:

- 1>. The capillary being insert too deep into the evaporator, so when the refrigerant is Jetting, the end of vibrating capillary will hit the inside of the evaporator.
- 2>. Vibration from the capillary touching the inside of the cabinet or air duct board, then when refrigerant is jetting.

Solutions:

- 1>. If the capillary is inserted too deep, heat it with the solder, and solder it again(Please noted, the deep inserted is not longer than 15mm), and vacuumize it and refill the refrigerant. (→4).
- 2>. If the capillary touch the inner cabinet and the air duct panel, adjust the position of the capillary and add the anti vibration compound (→5) (Fig.3).

○ Oil jammed noise

Fault: intermittent and deep jet noise coming from inside of the capillary.

Cause: Compressor oil flowing into the cooling system pipe work probably due to the capillary slightly out of alignment during transportation.

Solution: Clean the cooling system pipe, vacuumize it and refill with refrigerant. See (→4)

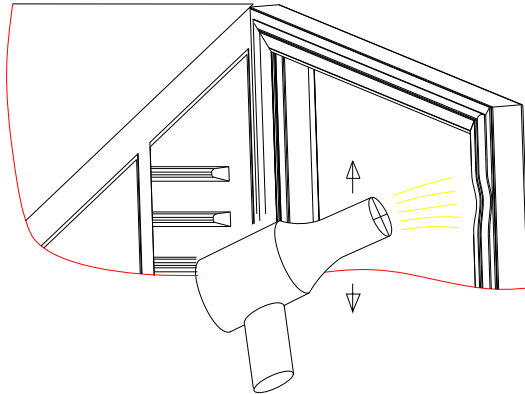

Fig. 8

▲ Evaporator freezing

○ Because the door seal is not air-proof, or the door is not closed well, cause much water fill in the cabinet, and the water got frozen when it encounter the cold air, sometimes the ice is too thick, and it will block the fan or broken the fan.

The solution:

1 >. Replace the door seal or close the door well. If the door seal is slightly not air-proof, it can be repaired by the heat dryer. Aiming at the distortion of the seal with the heat dryer, and move up and down until it expand to the normal state. When it is cool, check it with the door closed, if there is any distortion, dry it again until it fix for the door. See (Fig.8)

▲ The instability of the wine cellar temperature

The instability temperature is caused by evaporator's fan on/off.

Solution: When the compressor is on, the indicator light on control panel is on, the fan should be running. If not, check the fan's connector & fan. Once the fan is fault, please replace a new one (→8) (Fig. 6 & Fig. 6.1 & Fig. 6.2 & Fig. 6.3)

▲ Control system problems

○Fault finding by the self-check mode

Because this series' wine cooler is electrical controlled, in order to maintain and repair the wine coolers.

There is self-check function in the PCB board. If there is any default of PCB system, please start the self-check system. The method is as below.

1 > . Press and hold "Set lower"

and "Set upper" button with power on. 2 beeps will sound, and then the controller will start the self-check function

2 > . If everything is operating correctly, :

a. No response when pressing buttons.

b. LED reader display "____"

- c. The compressor works and the “RUN” indicator light are on all the time.
- d. The evaporator fan and condenser fan should be work. The refrigerant valve is on all the time.
- e. The switch controls the light functions normally.

3 > . If the situation fit for a~e statement, the spare parts are normal, if the control panel and the various components of the unit do not respond as above check the faulty part and relevant connection. If this does not cure the fault replace the control board. (→13、 →14、 →15、) (Fig.10.1 & Fig.11& Fig.12& Fig.13& Fig.14.1& Fig.14.2)

4 > . To return the control panel to its normal working mode unplug the unit and plug it in again

○Fault synchronous dual temperature model

1>. The LED display show HI, it is the high temperature protection indication. The elements is that machine will self-test after turning on 10 hours. If inner temperature is over 23°C, LED display show HI. Once it persist for 1 hour, LED display flash “HI” and beeper alarm is start. After beeper larm more than 20 minutes, compressor will be forced to stop, beeper alarm stop but HI code is still flash until turn off the machine.

Solution:

- A. If LED display of two compartments bother show HI, it cause by gas leak. Please find the maintain procedure to Page 4
- B. If LED display of one compartment show HI, it case as below:
 - a. The capillary is jamed. Please find the maintain procedure to Page 4
 - b. The refrigerant value is fault, please replace a new one. (→12) (Fig.9)
 - c. The evaporator fan is fault, please replace a new one. (→7) (Fig. 6& Fig.6.1)

2>. The LED display show LO, it is the low temperature protection indication. The elements is when the temperature of the cabinet is lower than 0°C, the system start up low temperature protection function, and now the LED display shows LO. , and the buzzer alarm, the machine is forced to stop, so as to protect the wine from damage. When the temperature of the cabinet is higher than 0°C, the protection will dismiss automatically, and the LED display show the actual temperature.

Note: the LO usually appear when the temperature set between 4~6°C, if the temperature set higher than 6°C, LO appear, and it is abnormal, the resolution is check whether there is any voltage outlet the refrigerant valve , if no, change the control board.

○ Sensor fault

Accorcding different model, there are 3 kinds of sensor

1. For synchronous dual temperature wine cellar’s sensor

1>. After turning on the power, if the LED display shows the temperature is similar with the ambient temperature, it is normal, if abnormal, please remove air duct board (→5、 →14) (Fig.2.1 & Fig.11& Fig.12), check the sensor connecter is well, if yes, the sensor is fault, please replace a new one.

a . The LED display shows E7, and it is the lower compartment sensor’s fault, check the connection wire and the main board

whether plough, if not , replace the sensor with the same module. (→7) (Fig.6)

b . The LED display shows E8, and it is the lower compartment sensor's fault, check the connection wire and the main board whether plough; if not, replace the sensor with the same module. (→7) (Fig.6)

c . The LED display shows E1, and it is the upper compartment sensor's fault, check the connection wire and the main board whether plough, if not , replace the sensor with the same module. (→7) (Fig.6)

d . The LED display shows E2, and it is the upper compartment sensor's fault, check the connection wire and the main board whether plough, if not , replace the sensor with the same module. (→7) (Fig.6)

2.For normal dual temperature wine cellar's sensor

1>. After turning on the power, if the LED display shows the temperature is similar with the ambient temperature, it is normal, if abnormal, please remove air duct board (Fig.2.1 & Fig.11& Fig.12), check the sensor connector is well, if yes, the sensor is fault, please replace a new one.

2 . Sensors of the dual zone without valve fault.

a . The LED display shows E1, and it is the upper compartment sensor's fault, check the connection wire and the main board whether plough, if not , replace the sensor with the same module. (→7) (Fig.6)

b . The LED display shows E2, and it is the upper compartment sensor's fault fault, check the connection wire and the main board whether short circuit; if not, replace the sensor with the same module. (→7) (Fig.6)

c . The LED display shows E3, and it is the lower compartment sensor's fault, check the connection wire and the main board whether plough, if not , replace the sensor with the same module. (→7) (Fig.6)

d . The LED display shows E4, and it is the lower compartment sensor's fault, check the connection wire and the main board whether short circuit, if not , replace the sensor with the same module. (→7) (Fig.6)

e . The LED display shows E7, and it is the frost free sensor's fault, check the connection wire and the main board whether plough, if not , replace the sensor with the same module. (→5) (Fig.3)

f. The LED display shows E7, and it is the frost free sensor's fault, check the connection wire and the main board whether short circuit, if not , replace the sensor with the same module. (→5) (Fig.3)

3.For single temperature wine cellar's sensor

1>. After turning on the power, if the LED display shows the temperature is similar with the ambient temperature, it is normal, if abnormal, please remove air duct board (→6) (Fig.4 & Fig.4.1), check the sensor connector is well, if yes, the sensor is fault, please replace a new one.

- a . The LED display shows E1, and it is the inner sensor's fault, check the connection wire and the main board whether plough, if not , replace the sensor with the same module. (→7) (Fig.6)
- b . The LED display shows E2, and it is the inner sensor's fault fault, check the connection wire and the main board whether short circuit; if not, replace the sensor with the same module. (→7) (Fig.6)
- e . The LED display shows E3, and it is the frost free sensor's fault, check the connection wire and the main board whether plough, if not , replace the sensor with the same module. (→5) (Fig.3)
- f. The LED display shows E4, and it is the frost free sensor's fault, check the connection wire and the main board whether short circuit, if not , replace the sensor with the same module. (→5) (Fig.3)

○ How to replace sensor.

1. The sensor fit on air duct board (the way is same for upper compartment and lower compartment)
 - 1>. Remove the shelves (→4) (Fig. 1& Fig.1.1)
 - 2>. Take our air duct board (→7) (Fig. 6& Fig. 6.1)
 - 3>. Take out 2 screws (2), the sensor cover is loosed, unplug sensor's connector on PCB board and take out the sensor, replace a new one. (→7) (Fig. 6)
2. Frost free unit's sensor (There is not any frost free unit's sensor for synchronous dual temperature wine cellar)
 - 1>. Remove the shelves (→4) (Fig. 1& Fig.1.1)
 - 2>. Take our air duct board (→7) (Fig. 6& Fig. 6.1)
 - 3>. Take out screw (3), take out the sensor (G), replace a new one. (→5) (Fig.3)

○Synchronous dual temperature wine cellar's refrigerant valve fault

- 1>. If the temperature of one compartment is normal, another compartment is abnormal or lower than setting temperature 3 °C, please check the exceptional compartment's refrigerant valve
- 2>. Turn off the power, change the two poles of the refrigerant valve, and turn on the power again, please pay attention to the sound snip-snap, or the refrigerant valve out off power or ruins. Replace the same module's refrigerant when confirming the electrical board is normal.
- 3 > . How to replace the refrigerant valve:
 - A. Use oxygen welding to heat the 3 welding point H, K , J, and then take off the refrigerant valve. (Fig. 9)

B. Use the cross screwdriver to wrest the refrigerant welding screw 1 (totally 2pcs, another isn't not in the picture.) (Fig.9)

C. Replace with the new refrigerant, and vacuumize it, and add refrigerant, complete the replacement.

3 > . How to replace the refrigerant valve:

A. use oxygen welding to heat the 3 welding point H, K , J, and then take off the refrigerant valve. (Fig. 9)

B. Use the cross screwdriver to wrest the refrigerant welding screw 1 (totally 2pcs, another isn't not in the picture.) ; (Fig.9)

C. Replace with the new refrigerant, and vacuumize it, and add refrigerant, complete the replacement.

Fig. 9

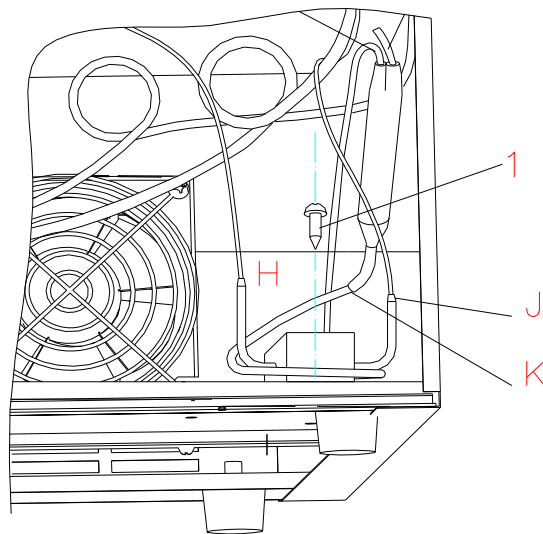

Fig. 9

○LED display fault:

This fault caused by led displayer , just change it will be OK. (→13) (Fig.10 & Fig.10.1)

○ How to replace the PCB board.

Here are two kinds of PCB board.

1. One is only the main PCB board fitted in electrical box or middle air duct board with transformer.

Please refer Page 13 (Fig.10 & Fig.10.1) for how to replace PCB board.

2. Another include two parts –

power PCB board which fitted in compressor compartment with transformer & main PCB

board which fitted in electrical box. (→14、 →15) (Fig.12 & Fig.13 & Fig.14.1 & 14.2)

3. For Normal dual temperature wine cellar

1>. Remove the shelves (→4) (Fig.1 & Fig.1.1)

2>. Take out upper middle air duct board (→4、 →6) (Fig.2.1 & Fig.4)

3>. Here is the drawing after remove upper middle air duct board. (→13) (Fig10& Fig10.1)

4>. Unplug all the connectors, then press the head of each of the four plastic screws (4) one by one, then remove the control board and replace the control board see (Fig. 10) (Vlew K)

5>. Remove the two transformer fixing screws (6) and replace the transformer (Fig. 10)

6>. How to replace display panel

Pull the four 4 display cover fasteners (D) as per arrowhead direction (Vlew I), and then remove the display board (E) and its two connectors from both sides. Replace the display board. See (Fig. 10) (Vlew I)

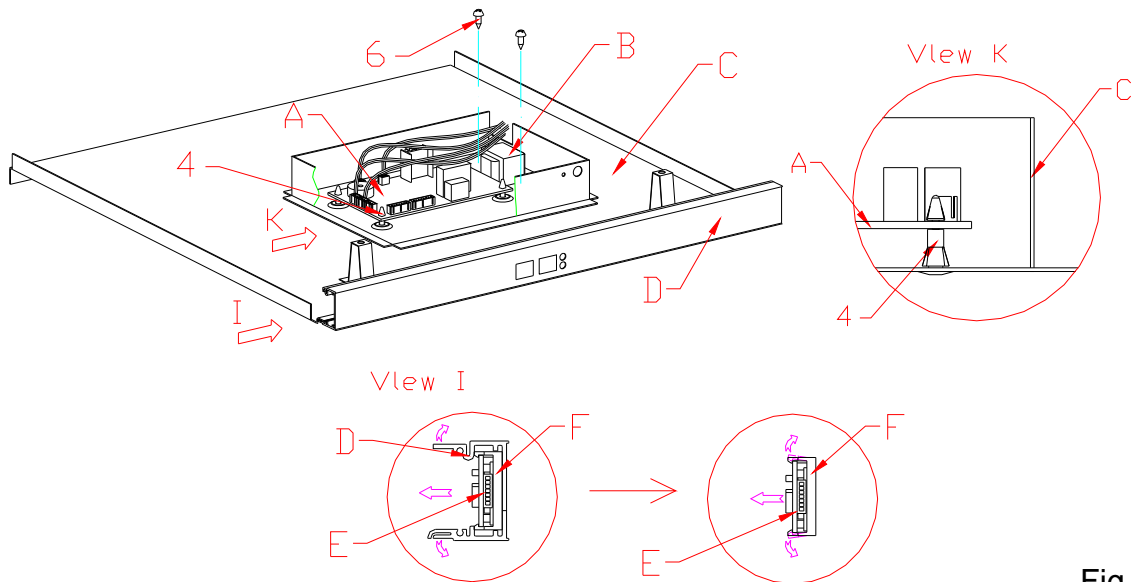

Fig. 10

4. The way to replace synchronous dual temperature wine cellar's PCB board is as same as normal dual temperature wine cellar's one

5. For single temperature wine cellar

1>. Remove electrical box (→6) (Fig.4)

2>. Unplug all the connectors, then press the head of each of the four plastic screws (4) one by one, then remove the control board and replace the control board see (Fig. 10.1) (Vlew I)

3>. Remove the two transformer fixing screws (6) and replace the transformer (Fig. 10.1)

4>. The way to replace display board is as same as normal dual temperature model

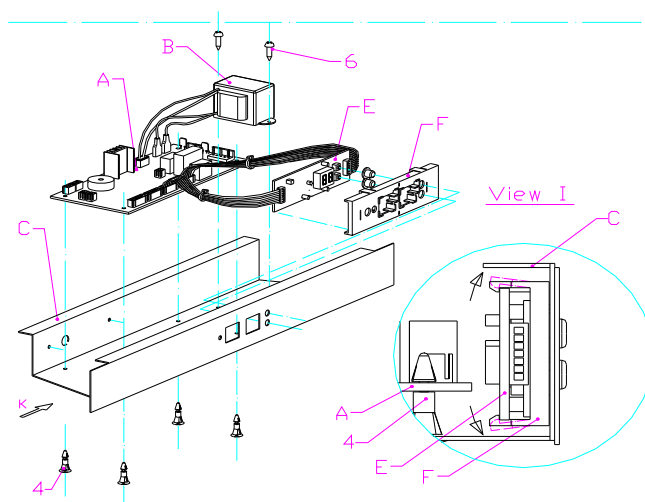

Fig. 10.1

Fig. 10.1

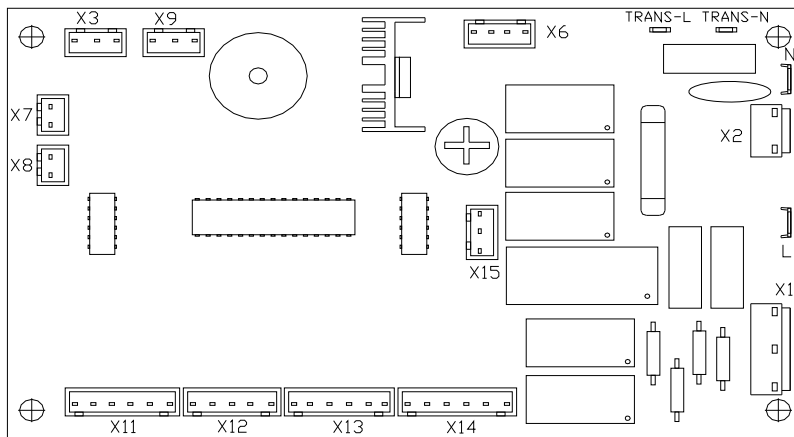

Fig. 11

○ This is drawing for normal PCB board (Fig. 11)

X1: Compressors connector

X2: Heater connectors

X3: Connectors of the lower zone evaporator fan

X6: The connectors of the transformer fan-out

X7: Connectors of the upper zone sensor (yellow)

X8: Connectors of the lower zone sensor (yellow)

X9: Connectors of the upper zone evaporator fan (yellow)

X11、 X12: Connectors of the lower zone display board

X13、 X14: Connectors of the upper zone display board

X15: Connectors of the LED light (red)(if fix white lamp no this connector)

N: Connectors of the main power N

L: Connectors of the main power L

TRANS-L: Input terminal of the transformer L

TRANS-N: Input of the transformer N

○ This is drawing for main PCB board (Fig. 12)

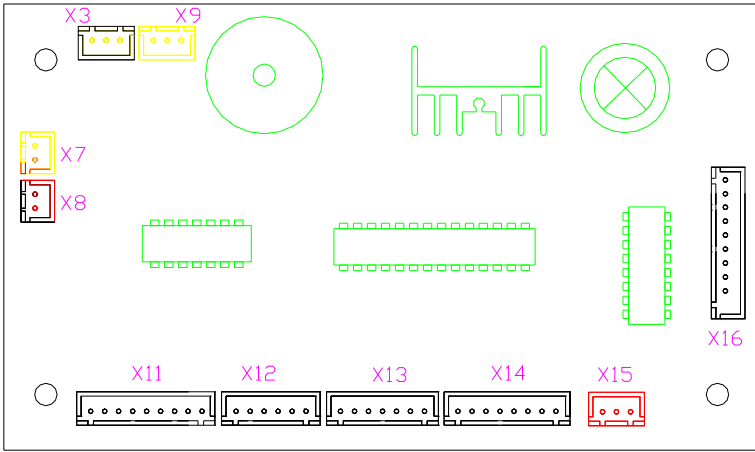

Fig. 12

X7: Connectors of the upper zone sensor (yellow)

X8: Connectors of the lower zone sensor (yellow)

X9: Connectors of the upper zone evaporator fan (yellow)

X3: Connectors of the lower zone evaporator fan (white)

X11、 X12: Connectors of display board

X13、 X14: Connectors of display board

X15: Connectors of the LED light (red)(if fix white lamp no this connector)

X16: Connectors of power PCB board

○ This is drawing for power PCB board (Fig. 13)

1. PTC heater connector (White)
2. Input terminal of the transformer L
3. Input terminal of the transformer (N) 4. Connectors of the main power N
5. Input terminal of the transformer L 6. Compressors connector
- 7 . Refrigerant valve connector 8. Mainer PCB board connector (White)
9. Condenser connector (Red) 10. Output terminal of the transformer

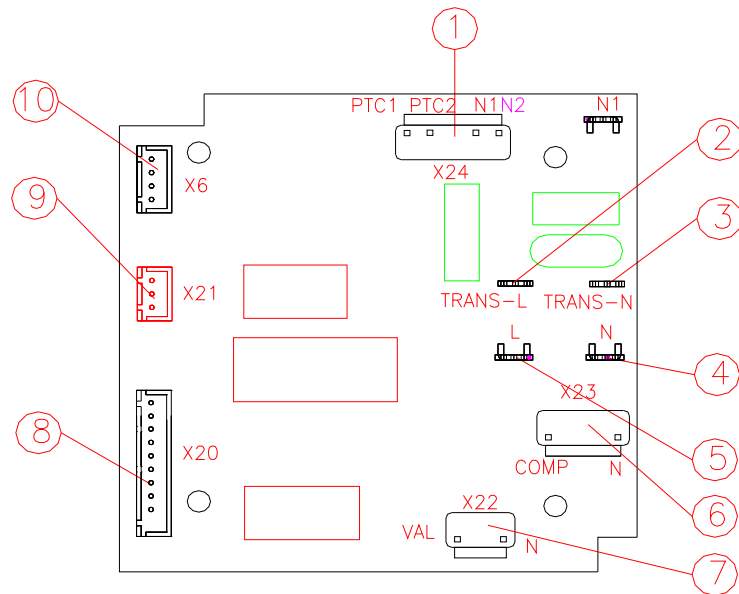
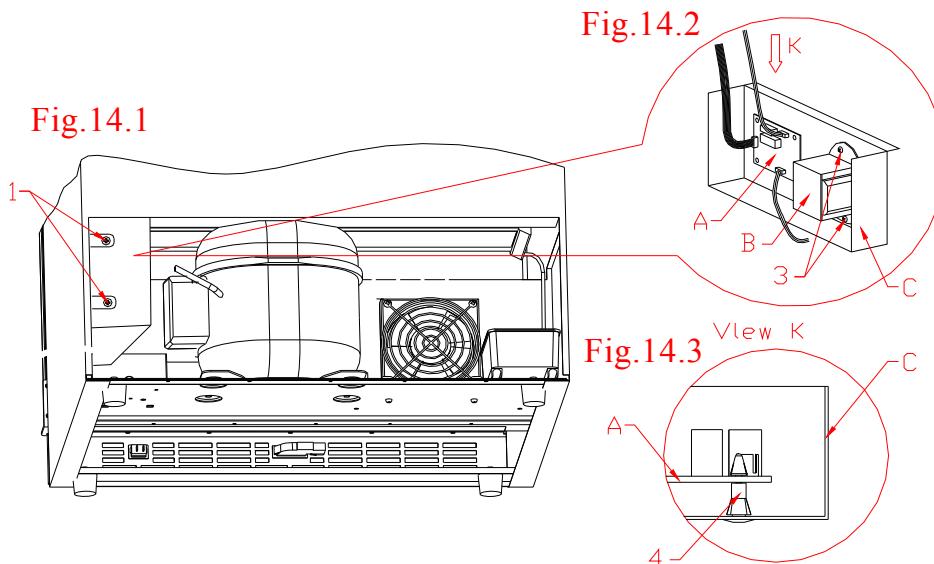

Fig. 13



○ How to replace power PCB board and transformer

1>. Remove the 2 screws (1) (Fig.14.1)

2>. Remove the electrical box (Fig.14.2)

3>. Unplug all the connectors, then press the head of each of the four plastic screws (4) , move up-ward the control board (A) , then replace a new one. (Fig.14.3) (View K)

4>. Plug all the connectors; (Fig.13)

5>. Remove the 2 screws (3) and transformer (B), then replace a new transformer.(Fig.14.2)

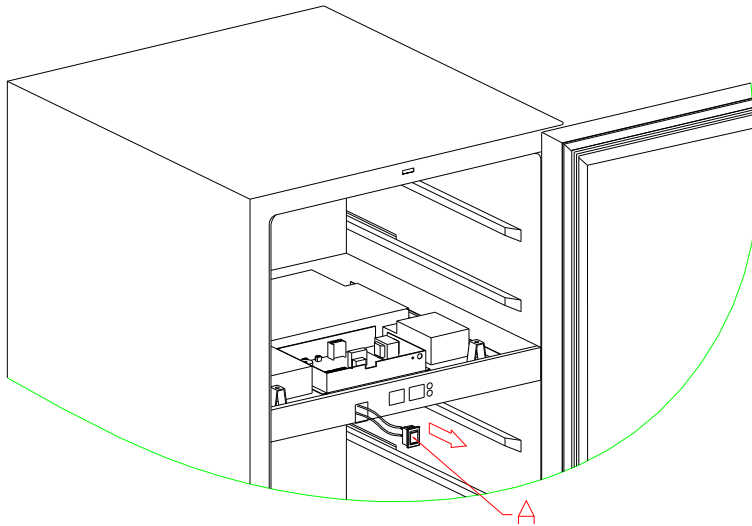

Fig. 15

○ How to replace light waved switch or power waved switch

1. For normal dual temperature wine cellar

1>. Remove shelves and upper air duct board (Fig.2.1)

2>. Pull out the switch from the lower air duct board follow the arrowhead's heading , pull out the connected line , then change the same spec of switch. (Fig.15)

2. The way to replace synchronous dual temperature wine cellar's waved switch is as same as normal dual temperature wine cellar's one

3. For single temperature wine cellar

1>. Remove shelves and upper air duct board (Fig.4)

2>. Pull out the switch from the electrical box follow the arrowhead's heading , pull out the connected line , then change the same spec of switch. (Fig.4.1)

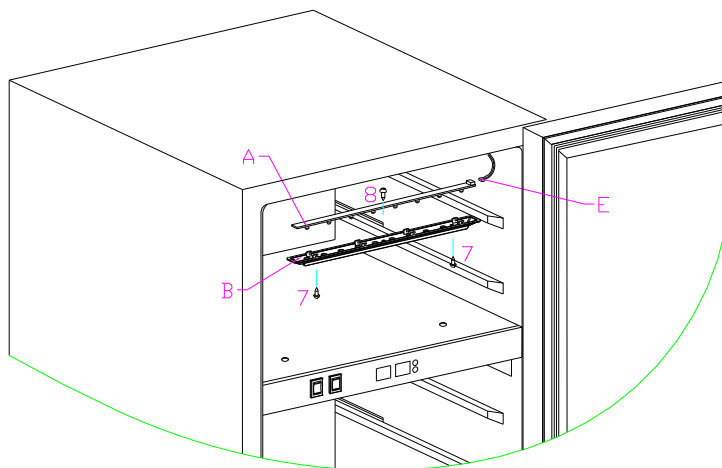

Fig. 16

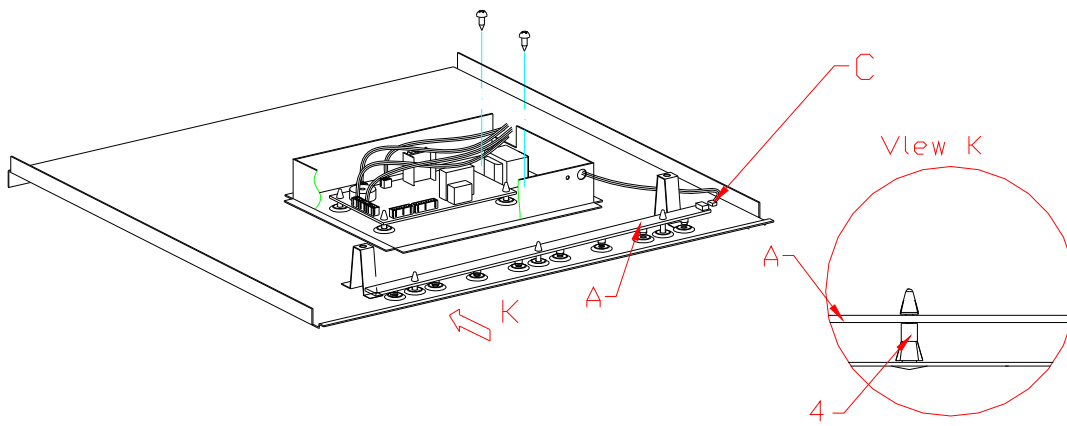

Fig. 17

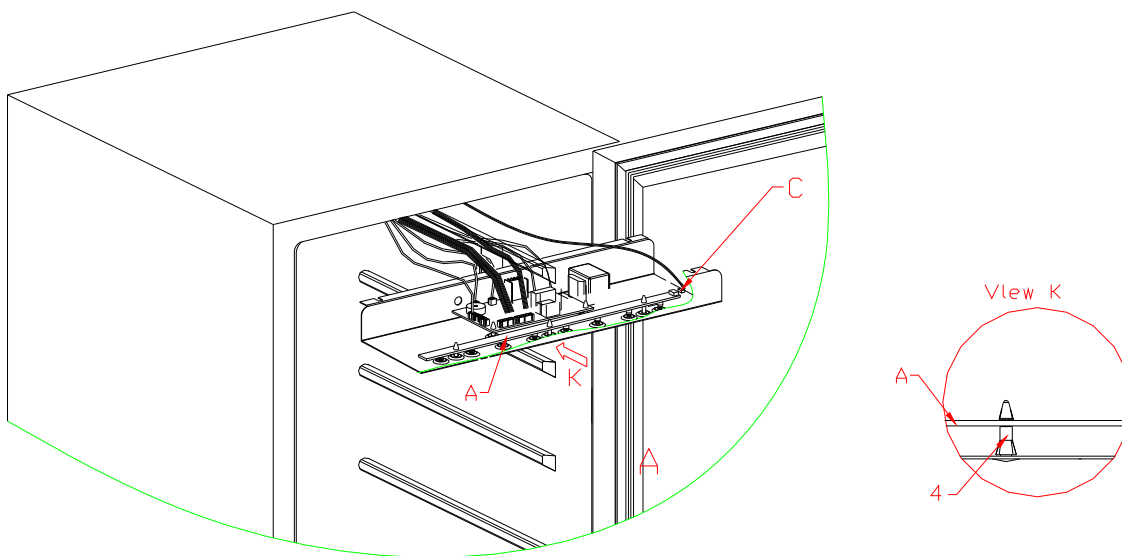

Fig. 18

○ How to replace LED light

1. How to replace normal dual temperature wine cellar's upper LED light (Fig.16)

1>. Remove upper compartment's shelves (Fig.1& Fig.1.1)

2>. Remove the two screws (7) which on light cover (B), then take out the light cover (B) (Fig.16)

3>. Remove one screw (8) on LED light, unplug connector (E), then replace a new one

2. The way to replace synchronous dual temperature wine cellar's upper LED light is as same as normal dual temperature wine cellar's one

3. How to replace normal dual temperature wine cellar's lower LED light (Fig.17)

1>. Remove the shelves (→4) (Fig.1& Fig.1.1)

2>. Remove upper air duct board (→5) (Fig.2.1)

3>. Unplug connector (C), press the head of each of the three plastic screws (4), move up-ward the LED light, then replace a new one (Fig.17)

4. The way to replace synchronous dual temperature wine cellar's lower LED light is as same as normal dual temperature wine cellar's one

5. How to replace single temperature wine cellar's LED light

1>. Remove the shelves (→4) (Fig.1& Fig.1.1)

2>. Take out electrical box (Fig.4)

3>. Unplug connector (C), press the head of each of the three plastic screws (4), move up-ward the LED light, then replace a

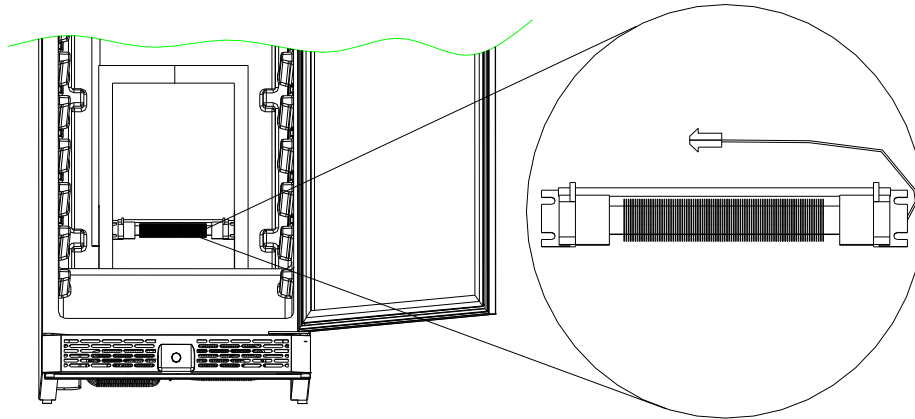

Fig. 19

▲Heating system problems

○ How to diagnose fault:

It should take approximate 3 hours when environment temperature is about 0°C. If refrigerating room is normal and chill room is lower than setting point (tolerance -2°C), please check heater fan & PTC heater. If these are working normally, there is probably heating system problems.

○Maintain the fault :

1. Check heater fan

If chill room is lower than setting point, the fan stop turning, please check fan connector, if connector is normal, it is fan fault, please replace a new one (→7) (Fig.6)

2. Check PTC heater

Check the cold resistance with multimeter, it should be 1.5kΩ, if incomplete circuit, please check connector, if connector is normal, please replace a new PTC heater (Fig.19)

○

How to replace PTC heater

1. For normal dual temperature wine cellar

1>. Remove shelves (→4) (Fig.1& Fig.1.1)

2>. Take out air duct board (→5、 →6、 →7) (Fig.2.1 & Fig.2.2 & Fig.2.3 & Fig.4 & Fig.6)

3>. Remove four screws on heater, then replace a new one (Fig.19)