



JLWF301

JLP 300mm 1 temp wine cabinet



TECHNICAL INFORMATION

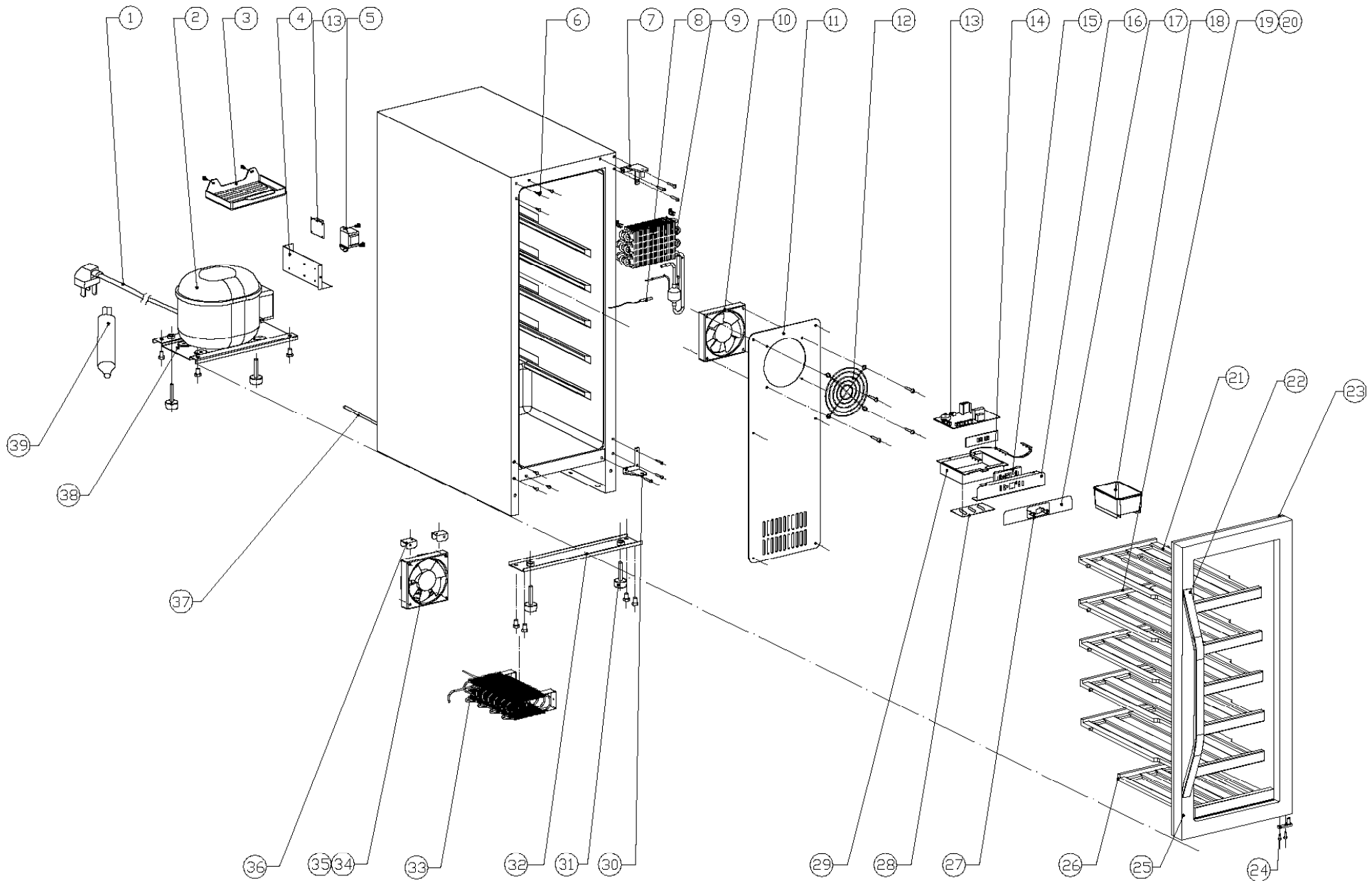

caple

JLWF301

JLP 300mm 1 temp wine cabinet



JLWF301 - JLP 300m 1 temp w.cell

Item	Part No.	Description	Qty
1	DG2-14	Power cord	1
2	DG1-72	Compressor	1
3	DG13-199	Water tank	1
4	DG13-272	Electrical box cover	1
5	DG6-7	Transformer	1
6	DG13-8	Decorative nail	6
7	DG14-15.2-SR	Top hinge module	1
8	DG8-8	Senser	1
9	DG12-44	Evaporator	1
10	DG7-40-BH	Evaporator Fan	1
11	DG22-209	Air duct board	1
12	DG19-1	Fan cover	1
13	DG3-98	PCB board	1
14	DG3-12-W	LED Light	1
15	DG13-327	Display support	1
16	DG13-383	Electrical box panel	1
17	DG20-168	Display panel	1
18	DG13-1.2	Humid box	1
19	DG15-26	Wooden shelf A9	4
20	DG15-25	Stainkess Steel edge,for wooden shelves	4
21	DG15-26.1	Wooden shelf A9A	1
22	DG13-411	cylinder knop	1
23	M130-001	Gasket	1
24	DG14-116-S	Door Axis	1
25	DG23-142	Door	1
26	DG15-27	Wooden shelf	1
27	DG13-130	Button	4
28	DG13-353	Airproof slice	1
29	DG22-395	Electrical box	1
30	DG14-167-SR	Lower hinge module	1
31	DG13-6.11	Cabinet leg	4
32	DG22-40	Support bracket of front legs	1
33	DG12-3	Condenser	1
34	DG7-24-H	Condenser fan	1
35	DG19-3	Fan cover	1
36	DG14-33	Bracket of fan (pair)	1
37	DG12-82-4	Air-circulating pipe	1
38	DG22-39	Compressor bracket	1
39	DG11-4	Drier	1



JLWF301

Caple Single zone wine cabinet

Service Manual

SERVICE MANUAL

(One temperature zone control wine cooler)

JG series includes JG18 series, JG32B,JG45AJG50A,JG50A-1,JG50FA

The content below shows different default might happen when the wine cooler is working, and also shows how to find the defaults and repair the defaults. Please find the corresponding default statement and find the repair information in the corresponding pages.

Statement: (Fig.4) shows the correlative diagram Fig.4

(→6) shows the correlative page 6

WARNING: Before attempting any cleaning or maintenance this unit Must be disconnected form the electrical supply, to prevent electrical shock.

▲ Preparation before maintenance

○ Tools

1. Pliers
2. Phillips head screwdrivers
3. Process pipe
4. Electrical Multi meter
5. Amp meter (5A) (caliper cable type)
6. Electrical soldering iron
7. Wire strippers
8. Seal pliers
- 9/ Scissors

○ Equipment

1. Vacuum pump
- 2.Soldering iron for copper pipes
- 3.Gas meter

▲ Cooling system fault

- How to Evaluate the fault(Page 3)
- How to repair the fault(Page 3)
- How to remove the air duct board (Page 4)
- Diagram showing the front side soldered joints(Page 6)
- Diagram showing the rear side soldered joints(page 7)

▲ Noise problems

- Compressor noise(Page 8)
- Fan noise(Page 8)
- Refrigerant jet noise (Page 9)
- Capillary vibration noise (Page 9)
- Oil jam noise(Page 10)

- ▲ Evaporator freezing problems.....(Page 10)

▲ Unstable internal temperature problems.....(Page 12)

▲ Control system problems

○ Fault finding by the self-check mode.....(Page 12)

○ Sensor fault(Page 12)

○ LED display fault(Page 14)

○ How to remove the electrical box (Page 14)

○ The dismantlement method of the electrical box spear part. (Page 14)

○ How to replace the light..... (Page16)

○ How to replace the Decorative frame..... (Page17)

△ Cooling system faults.

○ How to diagnose faults:

It should take approximate 3 hours to reach the lowest setting temperature of 5°C for an empty unit (assuming ambient temp of 32 degrees centigrade and continuous operation). If not, check the compressor, cooling fans, controller, and sensors. If all these are working normally, there is probably a cooling system's fault.

○ How to repair the default

1. Check the compressor

Turn on the unit and check there is electricity current flowing to the compressor using a caliper type Amp meter, the current should be within 0.6 to 2 Amps. If the readings are not in this range, turn off and cut off the pipes (See Fig.8 showing G) and the seal pliers (See Fig.8 showing E.) from the compressor, then turn the unit on again (**in this case only run the compressor for a few minutes, so as to avoid the compressor absorb moist air**) and recheck the current and if there is pressure at the outlet pipe. If the current reading is still out of range specified above and no pressure from the compressor outlet, replace the whole compressor.

2. Check the cooling system pipe work:

Carefully check the cooling system after verifying the compressor is working normally. Then follow the procedure below.

1>. Then cut off process pipe and check the refrigerant. If there is not enough refrigerant, the default of the refrigerant system should be caused by the leaking. If the refrigerant is sufficient., it is probably jamed in the capillary.

2>.If the default is concentrated on the cooling system, the checking procedure is as below.

A. Cut off the vent pipe of the compressor, and infuse 0.8-1MP nitrogen by process pipe, and please put the hand close to the cut kerf of the vent pipe. If there is a little gas leak form the terminal, it means normal, or it is jamed.

B. Make sure the capillary is working normally, when the drainpipe is conncted again, and infuse 0.8-1MP nitrogen then test the leakage if the cooling system of the soldering point with the soap water. Check from the the soldering point around the compressor(Fig.8 & Fig.9、Fig.9.1), and if everything is ok, remove the air-duct board and chech the soldering point around evaporator(Fig.6 & Fig.7). please see the remove method and the procedure as below. (Fig.1, Fig.2 ,Fig.3, Fig.4 & Fig.5)

C. If all the soldering point in B is not leaking, there are two possibility, one is leakage in the inner condenser, another is the damage on the parts (such as evaporator,condenser and so on) in the cooling system. If it is the inner damage, it can not be repaired, and if the damage on the parts, replace them.

3>. Make sure that there is not leakage in the cooling system, refill the refrigerant.

3. Refill the refrigerant:

1>. Using the vacuum pump form a vacuum in the system, via the joint of the low-pressure process pipe on the compressor , the high-pressure pipeline is on the process pipe of the filter. Apply the vacuum pump for approximately 20 minutes. Until the vacuum is lower than 100Pa. Then solder the compressor process pipe of the filter. Keep the vacuum running while soldering this joint

2>.Fill Cooling system with refrigerant via the process pipe. (The refrigerant is R134a. Regarding refrigerant quantity Please refer to the instruction at back label of wine cellar). Then solder the compressor process pipe after the system is charged with refrigerant.

4. Running test:

Replace all the components after the procedures above and turn the unit on. To verify the effectiveness of the repair, monitor

the unit the compressor should automatically stop within - 2.5 deg centigrade of the set temperature and start with +2.5 deg centigrade of the set temperature within approx 3 hours (assuming an ambient temperature of 32°C and the unit is empty).

○ How to remove the air duct board.

1.Remove the shelves firstly.

a. Remove the shelves; some models have Phillips head screws to hold other models have no screws (Fig.1)

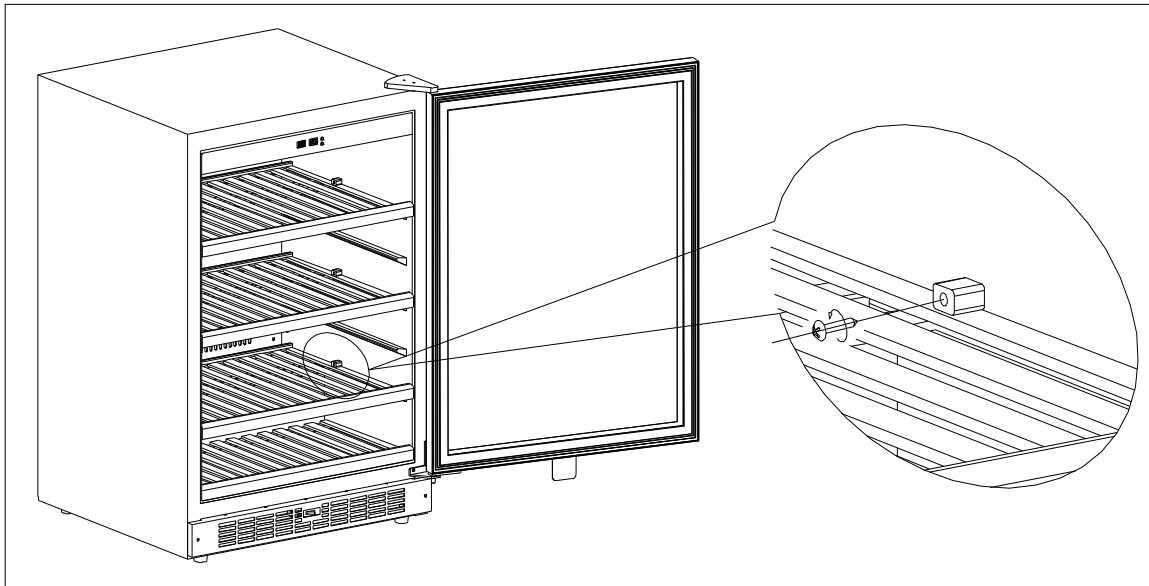

Fig.1

②. Pull the shelves to the bottom, circumscribe any side of the right and left, and let the setter of the shelf go out of the channel, and then draw out the shelves. (Fig.2)

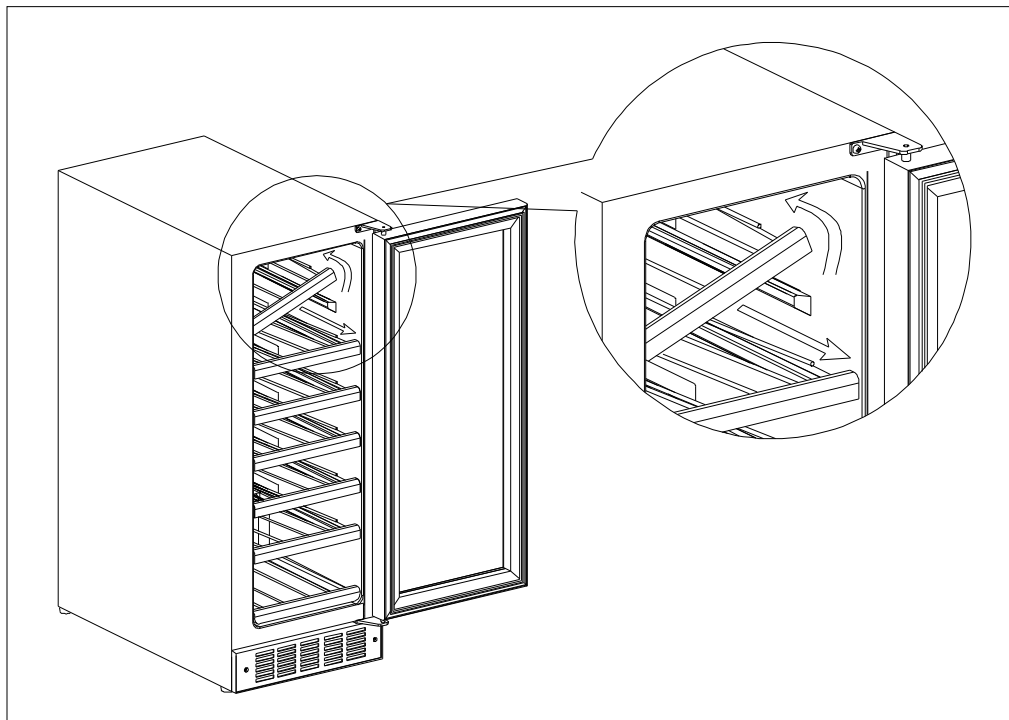

Fig.2

③. Drive up the shelves make it above the fixer 1 (Fig.3), then take it out according to the arrowhead Fdirection(Fig.4)

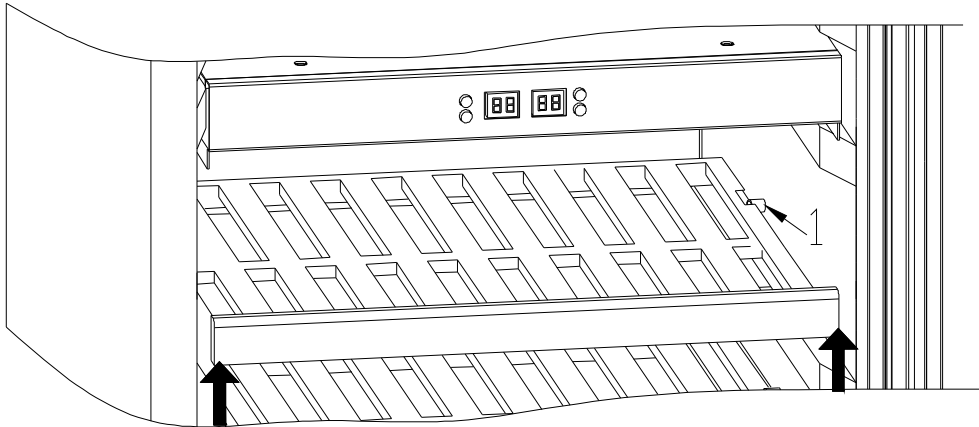

Fig.3

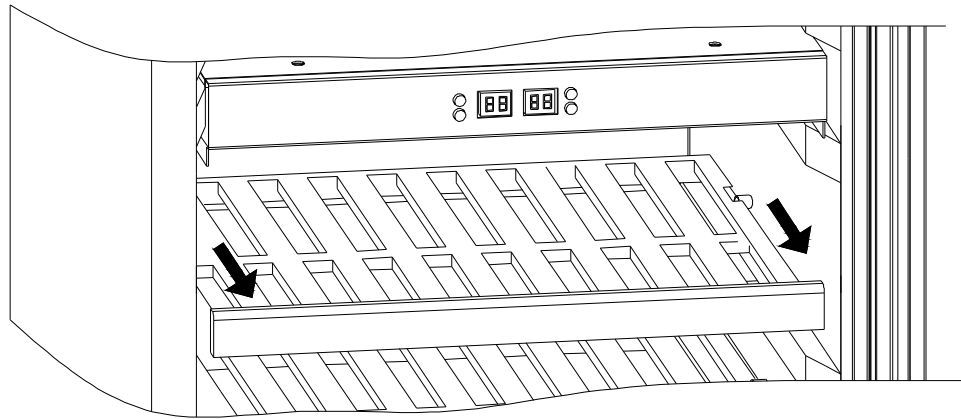

Fig.4

2>. How to remove the air duct board(A).(in Fig.5 1~10 are the screws fixing the air duct board,in different types,the situations and quantity of them are different,A~D are the screws fixing the fan,no need to remove),Remove the fixing screws of air duct board (1,2,3,4,5,6,7,8,9,10), then pull out air duct board (A). See (Fig 5)

Be attention to unplug the connection wire when removing the air-duct board. You can move slowly aside until you can see the fans wire, and unplug it, and then take out the whole air-duct board. ;

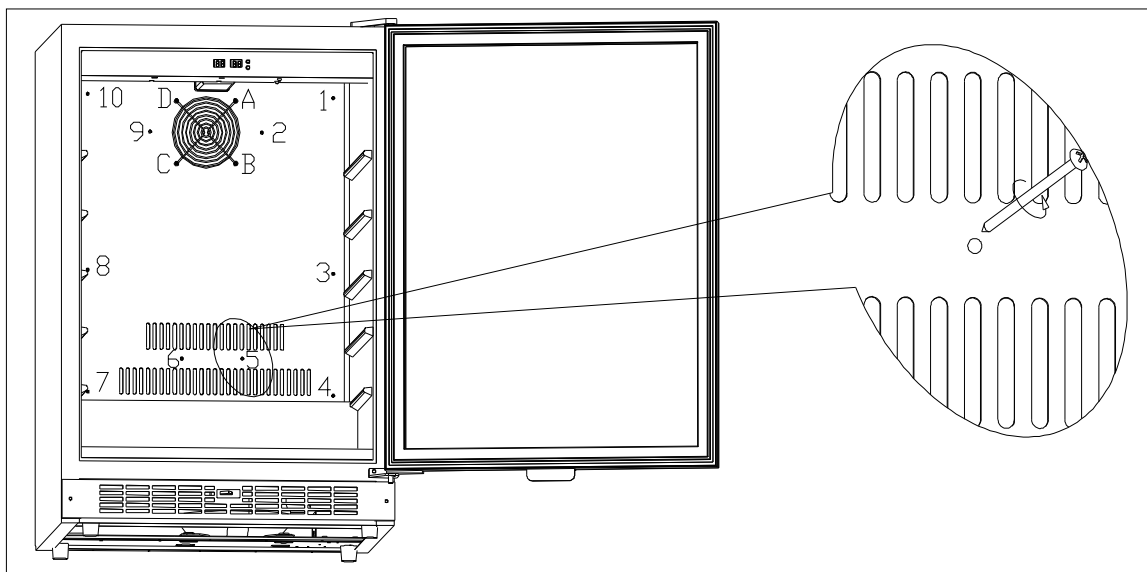

Fig.5

3>.For a View of the internal configuration after removal of the air duct board, see (Fig.6 & Fig.7)

○Diagram showing the front side soldered joints (There are two different types of evaporator:Finned and pipe evaporator,se (Fig.6& Fig.7)

A. Capillary soldered joints

B. evaporator soldered joints

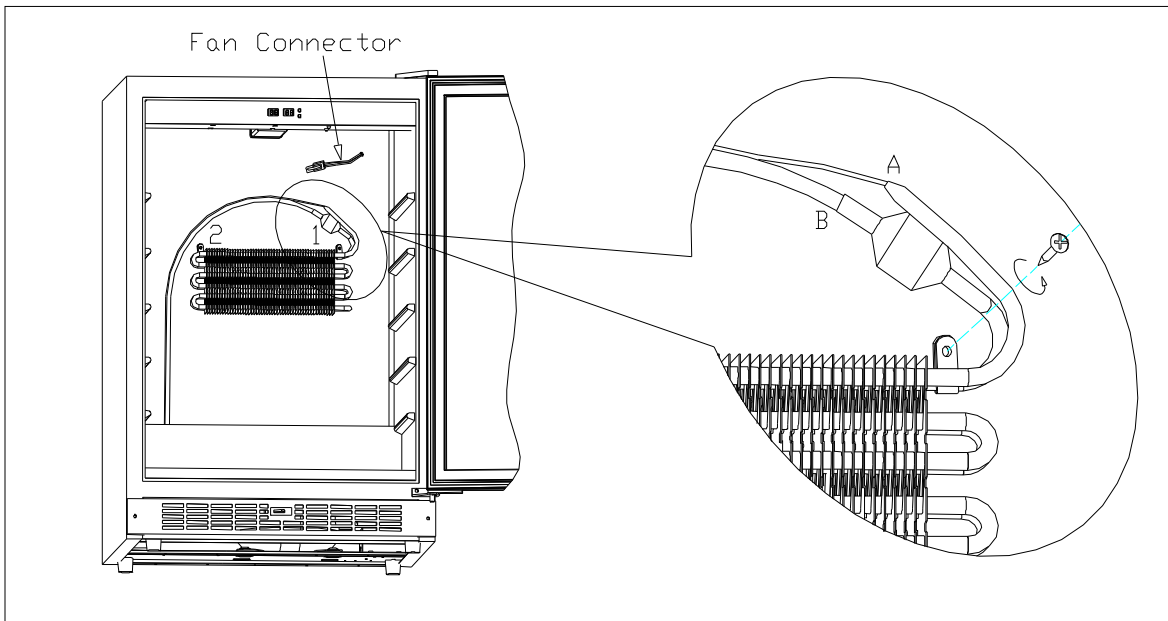

Fig.6

Finned evaporator

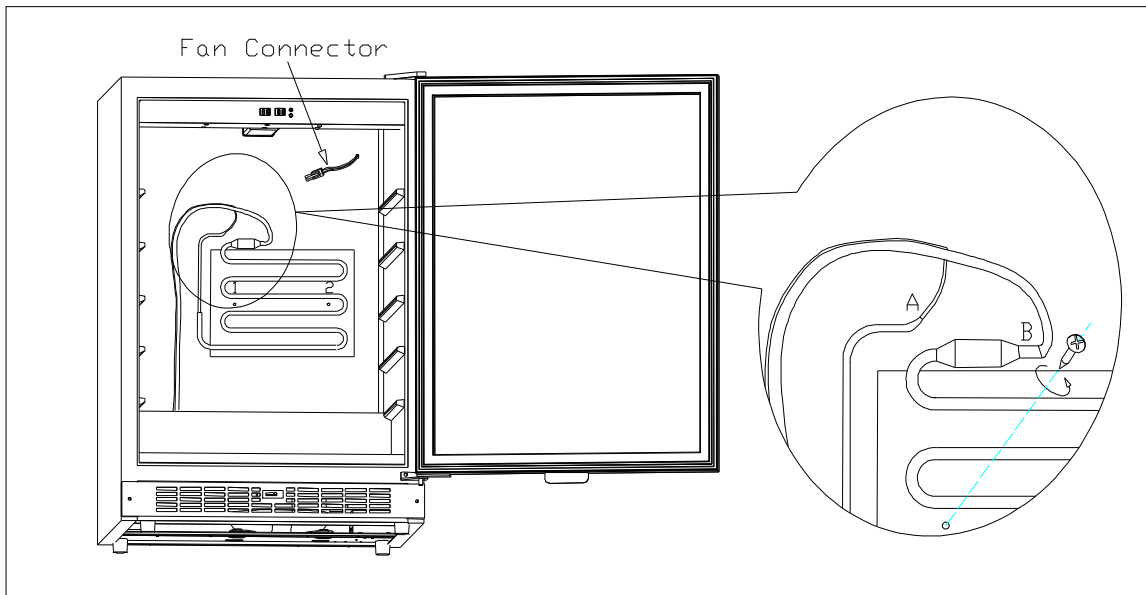

Fig.7

Pipe board evaporator

○ Diagram showing the rear side solder joints. There are two different condensers: built-in(Fig.8) and outboard condenser).See (Fig.9 & Fig.9.1)

- B: Dry filter process pipe soldered joint C: Dry filter soldered joint D: Capillary soldered joint
- E: Process pipe soldered joint F: Suction pipe soldered joint G: Discharge pipe soldered joint
- H: Condenser process pipe soldered joint I: Anti-Dew pipe soldered joint

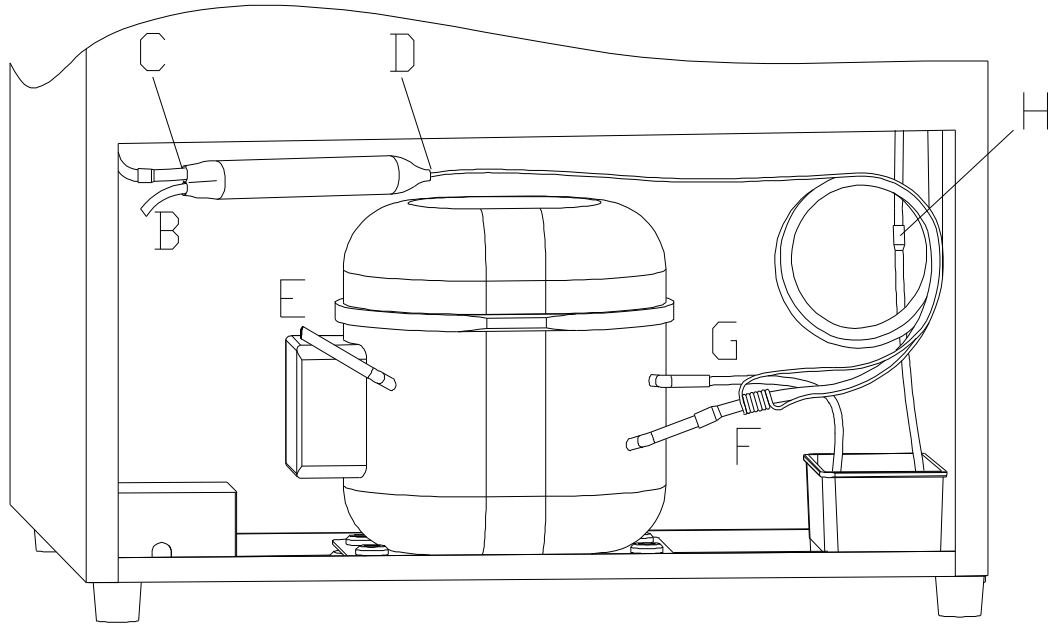

Fig.8

Built-in condenser

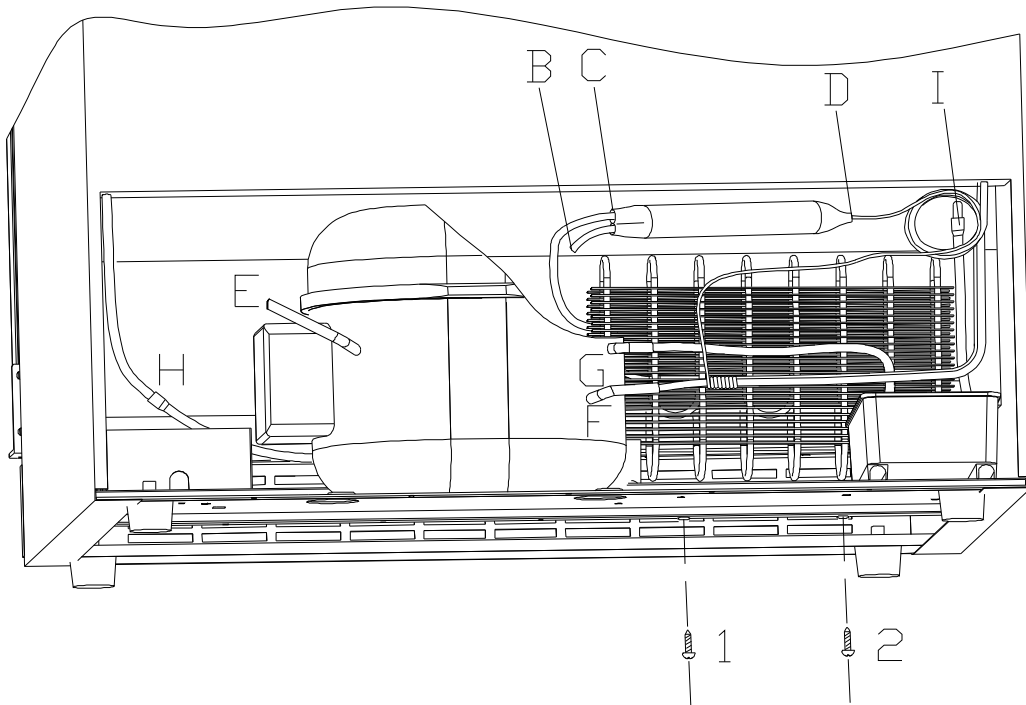

Fig.9

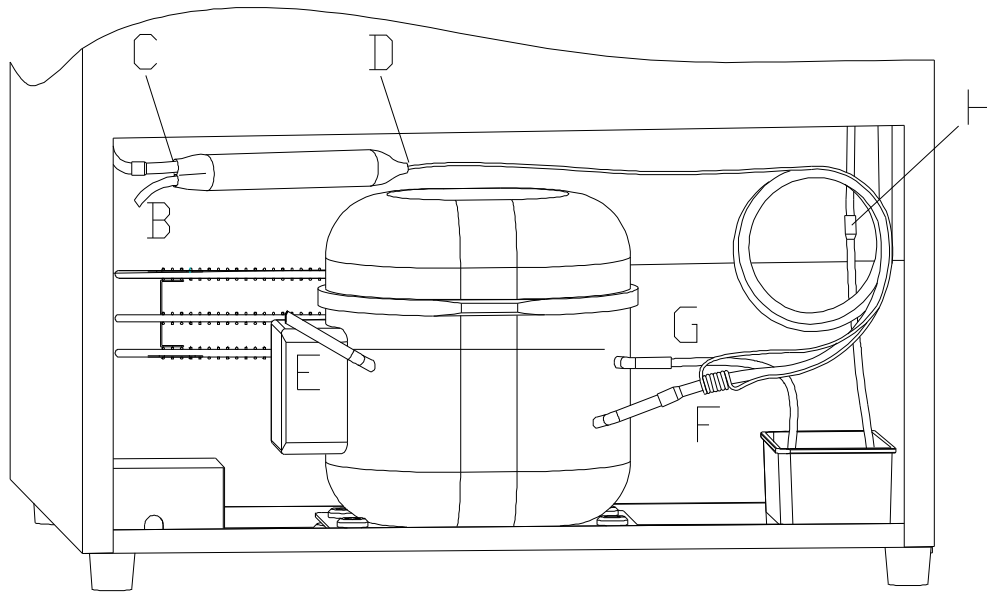

Fig.9.1

Outboard condenser

▲ High noise of wine cellar

○ compressor noise

1. The working of motor and piston motion will cause noise when compressor working. So if noise is steady and not exceeds 42 dB, it's normal. If noise is not steady or very high, it's compressor fault and it should be repaired or replaced.

2. If compressor's shock absorption rubber is hardening or damaged, or fixing screw of compressor is too tight or loose, it will cause noise. The settlement is to change new shock absorption rubber or adjust fixing screws.

○ Fan noise

1>. Normal fan motor and airflow should not exceed 32dB.

2>. If there is noise above 32 dB or the noise levels fluctuate, the fan shaft is either damaged or worn.

3>. How to replace the fans

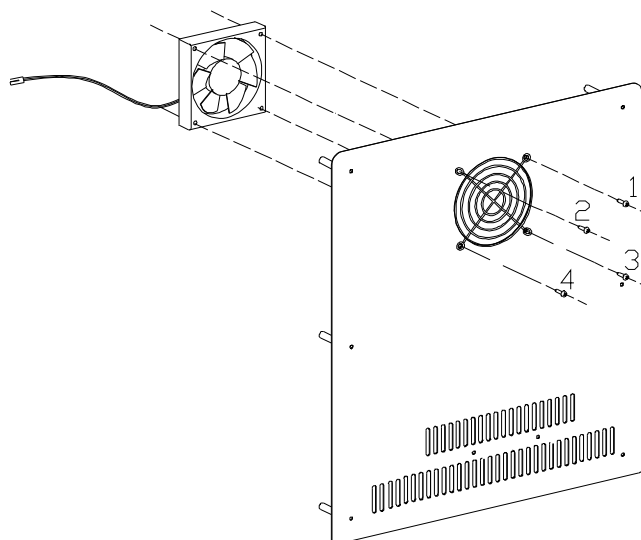

Fig.10

a. Replacing the evaporator fan

- 1>.Remove the shelf holde fixing screws, and remove the shelves. See (Fig.1, Fig.2 ,Fig.3,Fig.4)
- 2>.Remove the air duct board. See(Fig.5)
- 3>.Remove the fan fixing screws (1, 2, 3, 4), and replace the fan. See (Fig.10)

b. Replacing the condenser fan (different model may have different fan position, but the procedure for replacement is the same)

- 1>. Remove clip (A), then take off the electrical box cover of the compressor. See (Fig.11)
- 2>. Mark the two ends of the power cord of the fan (this is important to ensure replacement is correct),and then removes the power cords (C, D), (The figure is as per “ZEL” compressor; different compressor may have different power cord positions, see (Fig.11))
- 3>. Remove the two screws under the fan (1, 2), and remove the condenser fan. See (Fig.11)
- 4>. Remove the four fan securing screws (3, 4, 5, 6), and replace the fan. See (Fig.11.1)
- 5>. Re-assemble the unit

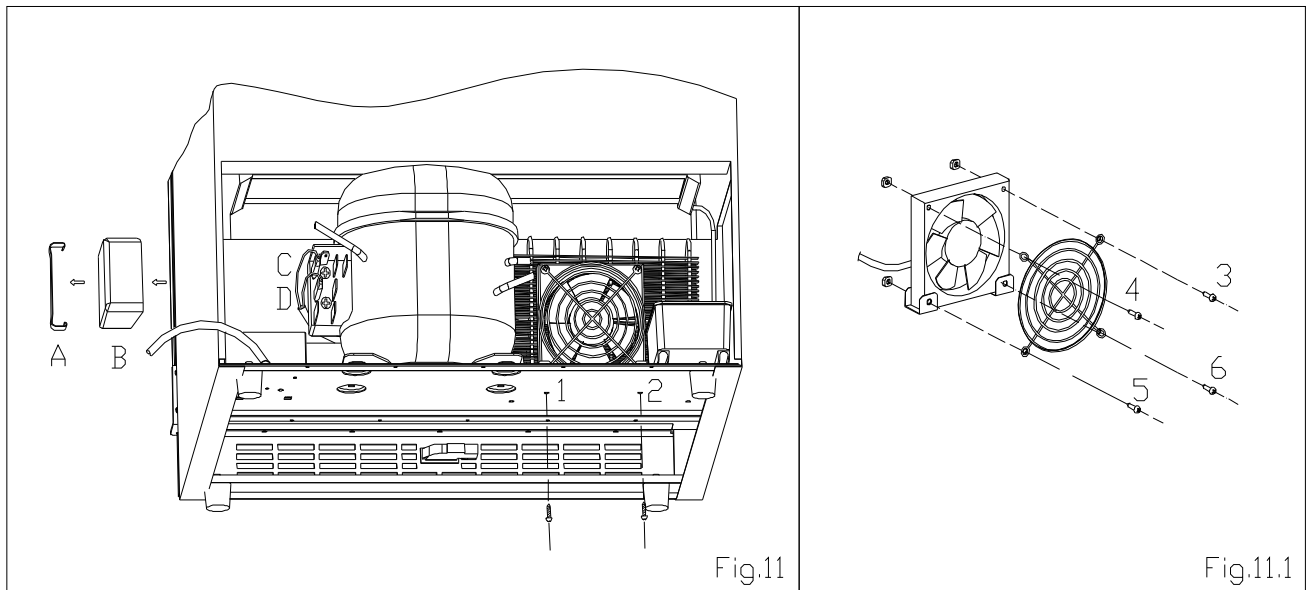

○ Refrigerant jet noise

If there is continuous noise like a water spray from the capillary, the end of capillary is in the wrong position, or there are rough edges on the end of the capillary.

- 1>.Heat the soldered joint of the capillary (A of Fig.8 and Fig.9, Fig.9.1), then remove the capillary from the evaporator and smooth the end with an eraser (Caution: Do not allow any particles into capillary unit)
- 2>.Replace the capillary into the evaporator, then solder it back into the correct position (not exceeding 15mm in the evaporator) and pack the joint with anti vibration compound
- 3>. Recharge with refrigerant. See (Page7)

○ Capillary vibration noise

Fault: Hight frequency impact noise in capillary zone

Caused by either:

- 1>. The capillary being insert too deep int the evaporator, so when the refrigerant is jetting, the end of vibration capillary will hit the inside of the evaporator.
- 2>. Vibration from the capillary touchig the inside of the cabinet or air duct board, then when refrigeran is jetting.

How to repair this problem

- 1>. De-solder the capillary and re-solder in the correct position avoiding contact with the inside of the evaporator, (The depth should be within 15mm), then recharge the unit with refrigerant see (→7)
- 2>. If the capillary touches the inside of the cabinet or air duct board, you should adjust position of capillary and pack it with anti-vibration compound. (Fig.8 & Fig.9、 Fig.9.1)

Oil jammed noise

Fault: intermittent and deep jet noise coming from inside of the capillary.

Caused by: Compressor oil flowing into the cooling system pipe work because of wine cooler lean during transportation, and the jetting oil in the capillary cause noise.

Solutions:

Clean the cooling system pipe, and recharge with refrigerant see (page 7)

▲ Evaporator freezing

○ This is normally due to

A/ Poor seal between door and door frame

B/ The door not closed correctly for a long period of time

This allows moist air into the cabinet, which freezes in the evaporator, if the ice is allowed to get too thick, it may damage the fan.

1>. Ensure door is sealed against the frame, if there is slight distortion of the seal, heat the effected area gently with a hair dryer genrly see (fig 12) with smooth strokes of the hair dryer, then when still warm pull the effected area back into its original position, this process may have to be repeated until the seal is completely back to its original condition.

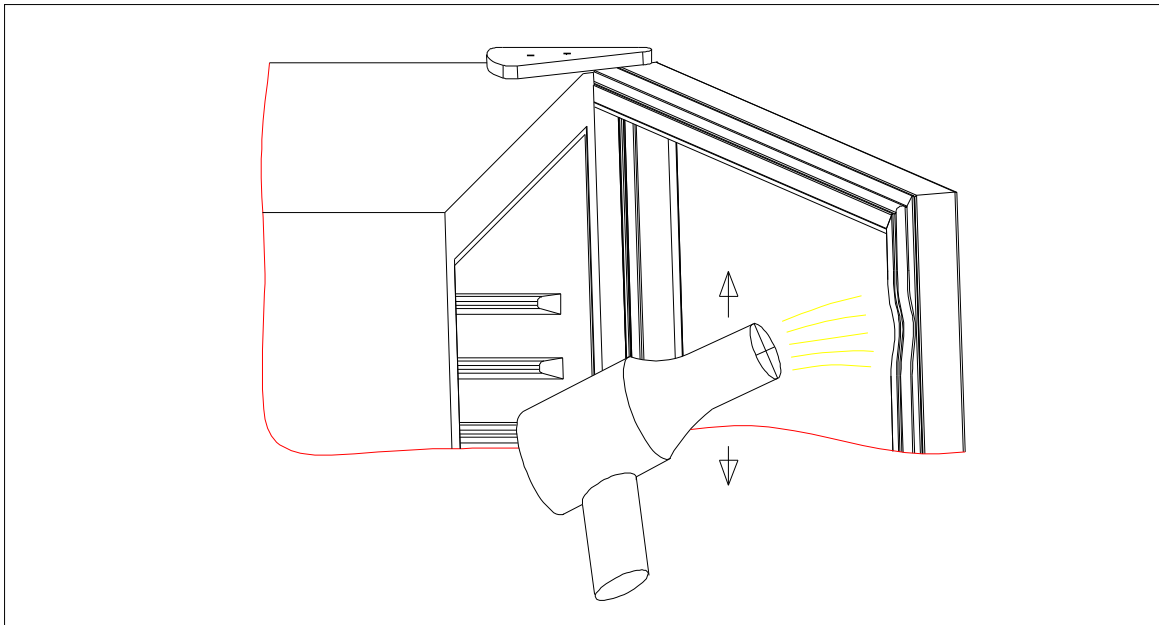

Fig.12

2>. If the ice has damage the fan it will need to be replaced see. (Fig.10)

○In some older models, the electrical connector of the fan wires is fixed under the evaporator, and water from evaporator may drip onto this junction box ,this may effect the electrical connection ,causing the fan to stop. Which in turn causes surface freezing.

1>. Remove the air duct board see(Fig.1, Fig.2 ,Fig.3, Fig.4 & Fig.5), remove the cable clip securing screws(A), and remove the cable clip see (Fig.13)

2>. Cut off the both connectors see. (Fig.13.1)

3>. Strip the ends of the wires about 12mm and re-connect then.

Ensure this electrical joint is sealed against future water damage, and is electrically safe(Fig.14)

4>. Fix the wire in the correct position using the cable clip with screw (Fig.15)

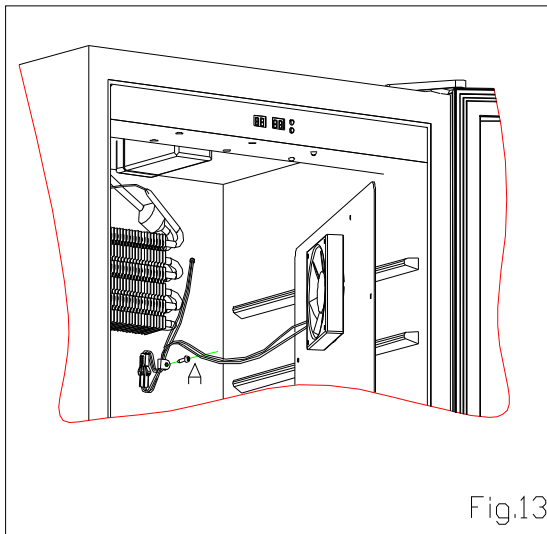

Fig.13

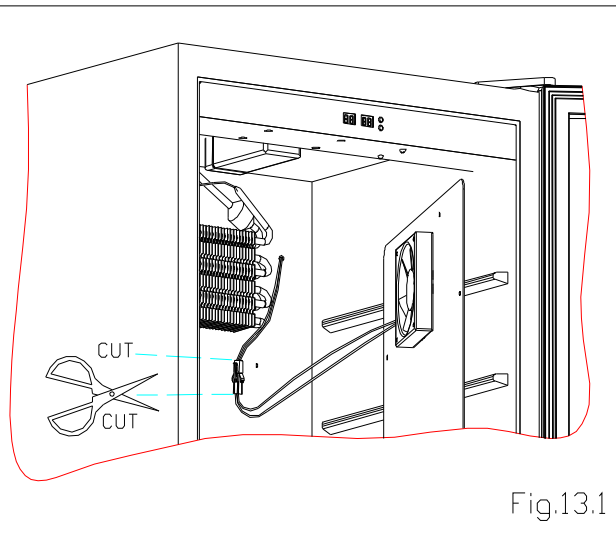

Fig.13.1

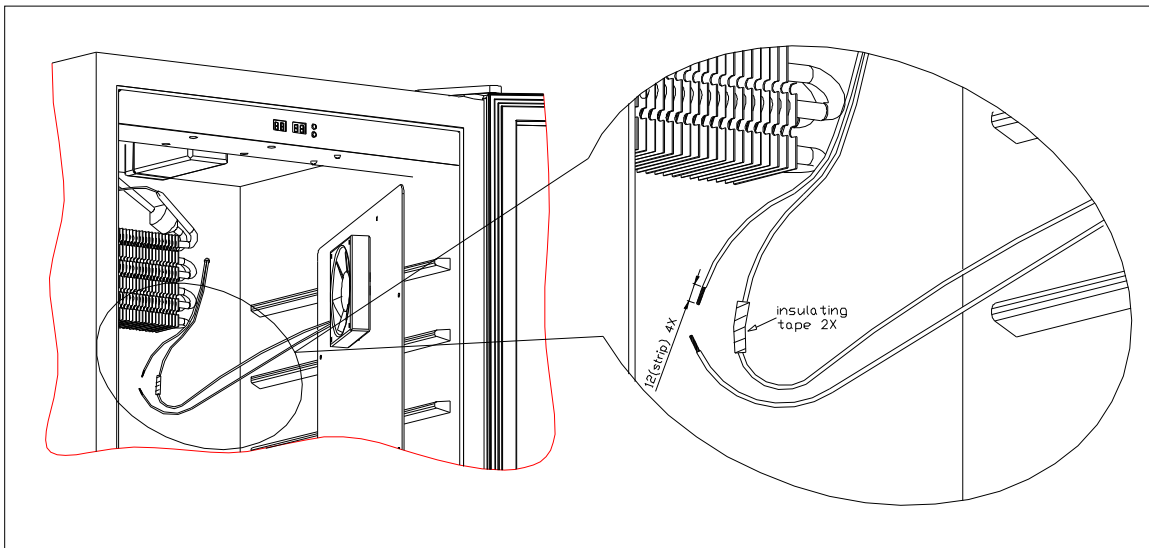

Fig.14

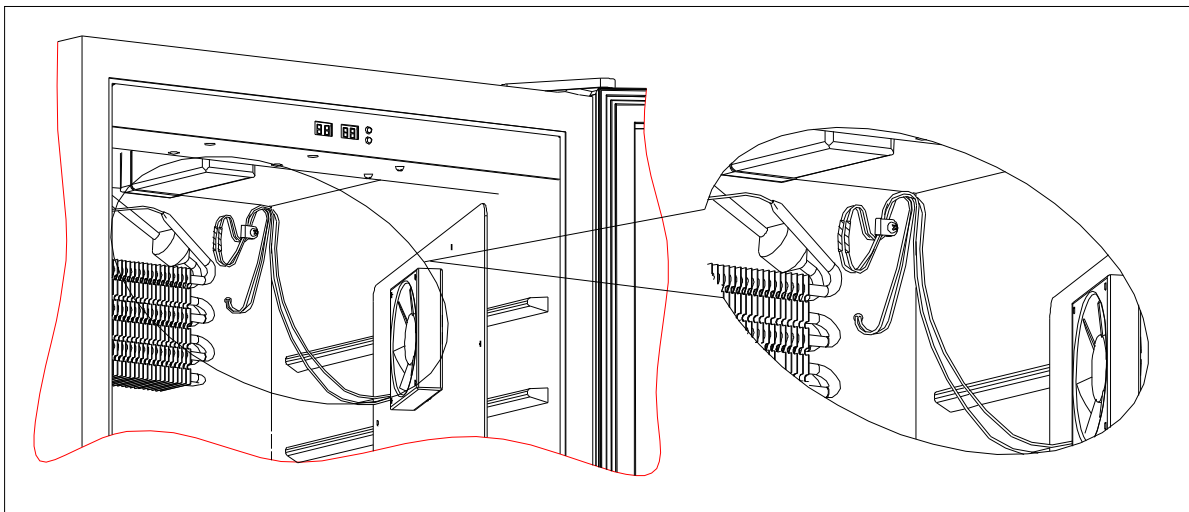

Fig.15

5>. If fan is fault ,please relace the whole fan.

6>.Note:the upper method only for the connector fixed under the evaporator.

▲ Unstable temperatures inside the cabinet

Unstable temperatures inside the cabinet is mostly due to a fault in the evaporator fan, you can check this by: When compressor works, the “RUN” indicator light should come on and the fan should spin, If fan does not spin check the fans electrical connections are faulty and repair them or if the fan is damaged replace the whole fan unit see (fig 10).

▲ Control system fault.

- Use the self-check mode to check this fault.

This series wine cellar has a computerized controller with built in self-check function.

Start the self-check mode as follows:

- 1 >. Press and hold “Set lower” and “Set upper” button with power on. 2 beeps will sound, and then the controller will start the self-check function
- 2 >. If everything is operating correctly:
 - a. No response when pressing buttons.
 - b. The LED display is: “— —“
 - c. The compressor works and the “RUN” indicator light are on all the time.
 - d. The condenser and evaporator fans (Some models do not have evaporator fan) work at full speed
 - e. The switch which controls the light functions normally
- 3 >. If the control panel and the various components of the unit do not respond as above
Check the faulty part and relevant connection. If this does not cure the fault replace the control board see (Fig.18 & Fig.19)
- 4 >. If you return the control panel to its normal working mode, please pull out the plug and plug it in again

- Sensor fault

- 1 >. Normally the LED temperature display should show the ambient temperature shortly after the unit is plugged in, if not, disassemble the electrical box see (fig 18), check if the sensor plug marked “X1” “X10” connected properly, if these connections are made correctly and the fault persists replace this sensor after the air duct board(Fig.1, Fig.2, Fig.3, Fig.4 & Fig.5).
- 2 >. If the LED displays” E1” ” E2”, it indicates the sensor “E1” ” E2,” should be replaced the sensor on the evaporator (Fig.16, Fig.16.1)
- 3 >. Take off the screw (A) and cable clip (Fig.16);
- 4 >. Cut off the fault sensor, please noted that do not cut too long of wire (Fig.16.1);

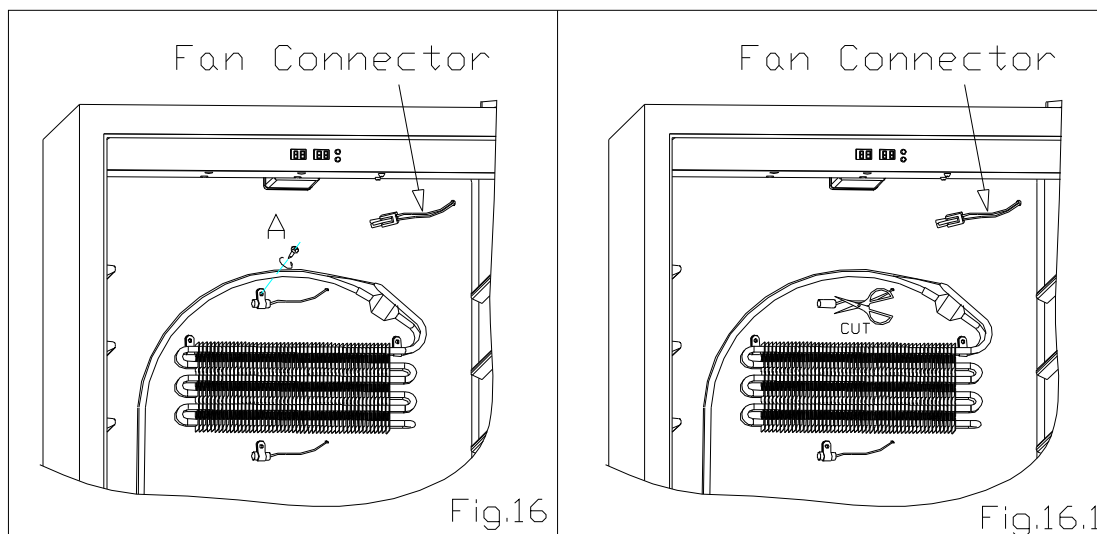

5>. Strip the ends of the wires, cut of the connect of new sensor and strip the ends of wires about 12mm , re-connect them.

Ensure this electrical joint is sealed against future water damage, and is electrically safe

Fix the wire in the correct position using the cable clip with screw(Fig17& Fig17.1)

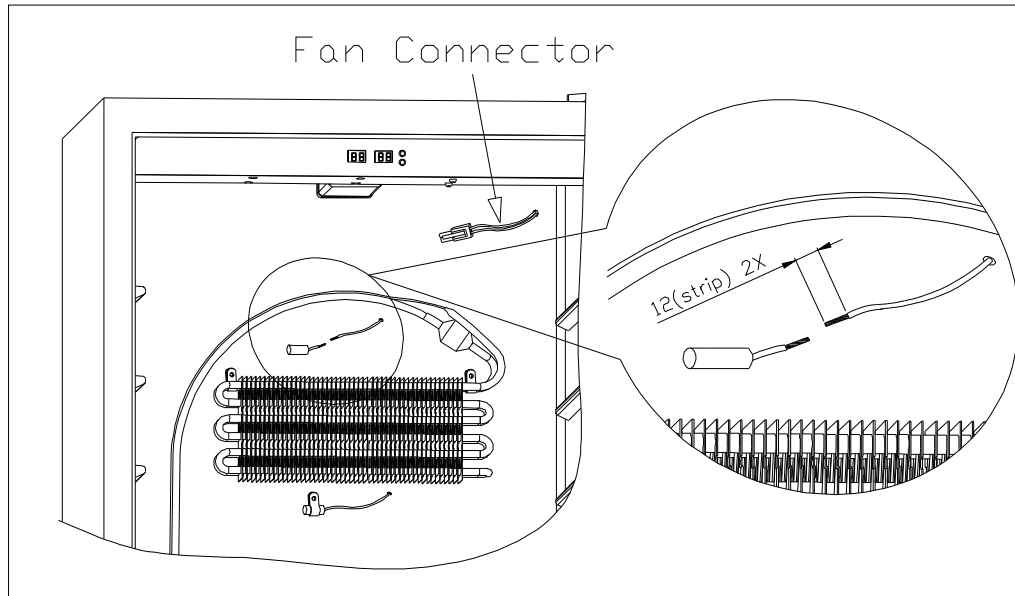

Fig.17

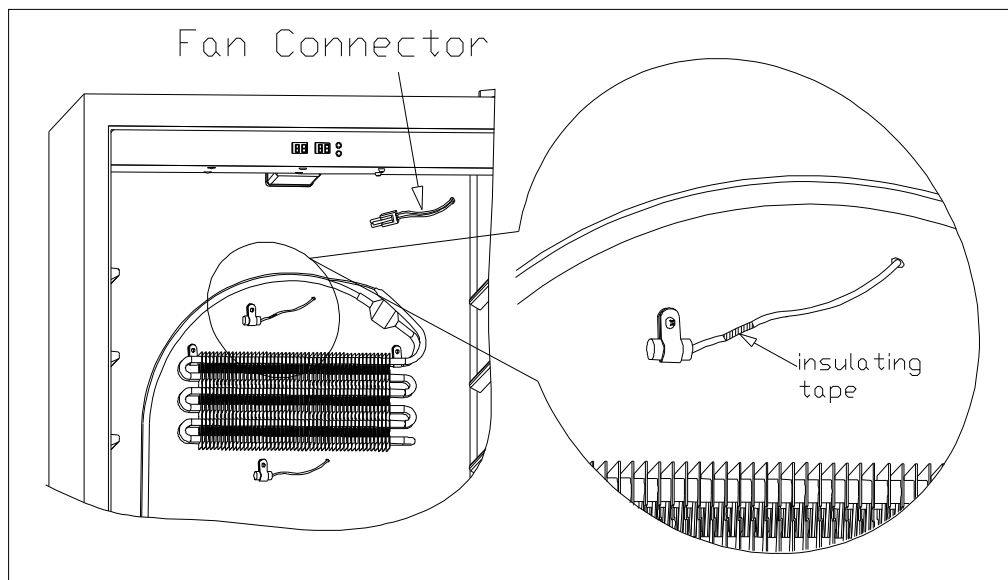

Fig.17.1

6 >. If the LED displays” E3” ” E4”, it indicates the sensor “E3” ” E4,” should be replaced the anti-frost sensor under the evaporator (The replacement method is as same as below)

○ Since the location of sensor on the old model is difference, check the sensor as below:

1 >. Normally the LED temperature display should the ambient temperature shortly after the unit is plugged in, if not, disassemble the electrical box see (Fig.18 & Fig.19), check if the sensor plug marked “XI” connected properly, if this connection is made correctly and the fault persists replace this sensor,

- 2 >. If the LED displays” E1” it indicates the inner sensor should be replaced see (Fig.18 & Fig.19)
- 3 >. If the LED displays” E2” it indicates the inner sensor should be replaced see (Fig.18& Fig.19)
- 4 >. For some older models with old computerized control panels,If the LED displays 37°C, 99F or, infinity, replaces the sensor. See(Fig.18& Fig.19)

○ LED display error

Replace the electrical display board fault; see (Fig.18& Fig.19)

○ How to remove the electrical box.

- 1 >. Remove the shelves; see (Fig.1, Fig.2 ,Fig.3,Fig.4)
- 2 >. Remove the two screws at back of electrical box (2,3), then half-remove the two front screws (1,4), then remove the electrical box; see (Fig.18)

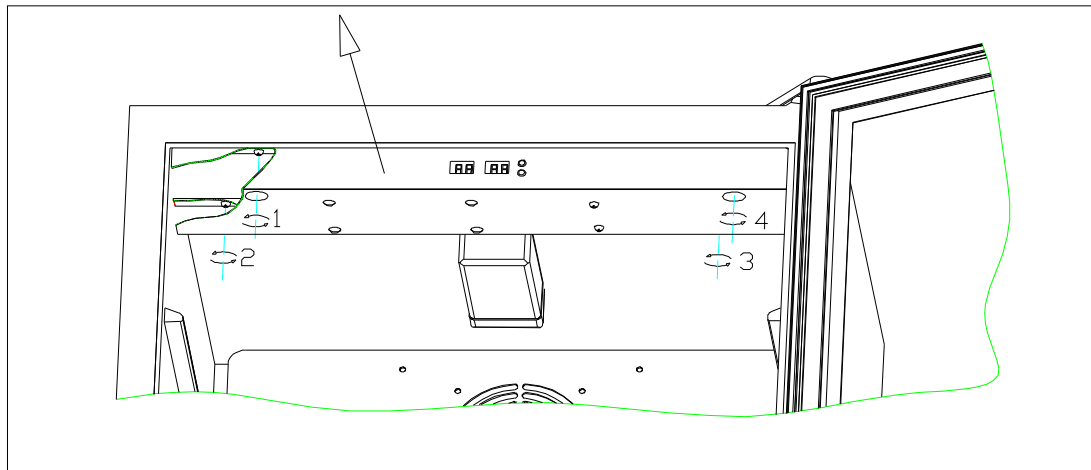

Fig.18

- 3 >. Remove the sensor fixing screw (1), unplug the other end from “X1” housing of the control board, and fit a new sensor; see; (Fig19)
- 4 >. Unplug all the connectors, then press the head of each of the four plastic screws (4) one by one, then remove the control board and replace the control board see (Fig.19)
- 5 >. Remove the two transformer fixing screws and replace the transformer (6);(Fig.19)
- 6 >. To replacing the display board,
Pull the four 4 display cover (8) fasteners as per arrowhead direction, and then remove the display board and its two connectors from both sides. Replace the display board. See (Fig.19)

○ The dismantlement method of the electrical box spear part.

There are two type of electrical box,old and divide version.

PCB board has two modes:

model1: PCB board is a complete block,and in the electicial box of the same box with the transformer;(Fig.19)

model 2: PCB board divide into 2 blocks, the main PCB board is in the electrical box(Fig.22),the other power PCB board is in the left of the compressor’s box with the transformer. (Fig.21)

1>.The old structure electrical removalent.

Unplug all the connectors from the control panel, and press the 4 studs (4) one by one, and up draw the control panel, Replace it with the same model’s PCB board; (Fig.19)

2>.The divide structure electrical removalent.

A. How to replace the main PCB

- a. Remove the the shelf , (Fig.19)
- b.Unplug all the connector, press the 4 studs (3) one by one. Updraw the control PCB board, and draw off the PCB board, , replace it with the same model's PCB board. (Fig.19)

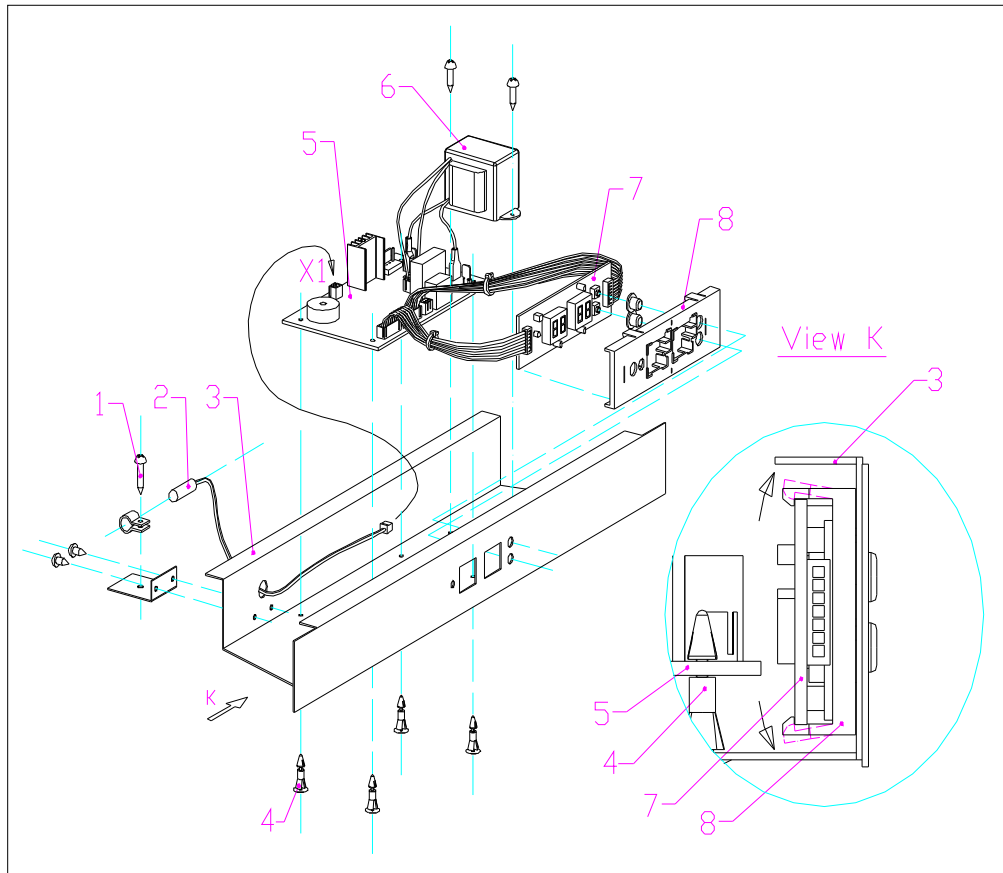

Fig.19

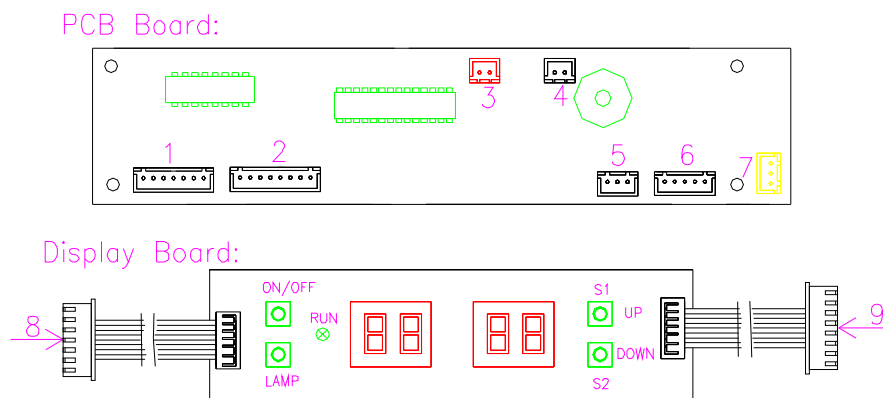

Fig.20

Diagram of the main PCB(Fig.20).

- | | |
|---------------------------------|---------------------------------|
| 1. To display PCB(connect to 8) | 2. To display PCB(connect to 9) |
| 3.To evaporator sensor (Red) | 4.To inner sensor(White) |
| 5.To LED light (White) | 6.To power PCB (White) |
| 7. To outer fan (Yellow) | |

B.How to replace the power PCB and transformer.

- a. Remove the two screw(1) that fixing the electrical box for power PCB (Fig.21).
- b. Remove the the electrical box(C) for power PCB (Fig.21).
- c. Unplug all the connector, press the 4 studs (4) one by one. Updraw the power PCB board(A), and draw off the PCB board, , replace it with the same model's PCB board. (Fig.21) (Vlew K)
- d. Remove two fixing screw(3) of the transformer (B) , take off the tranformer (B) for replacement. (Fig.35),Divide version control panel connections (Fig.21)

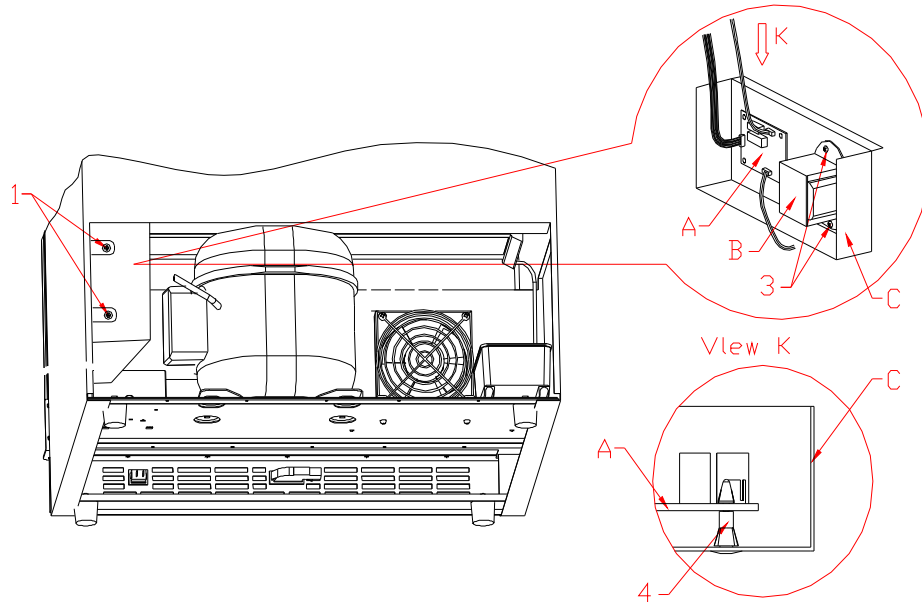

Fig.21

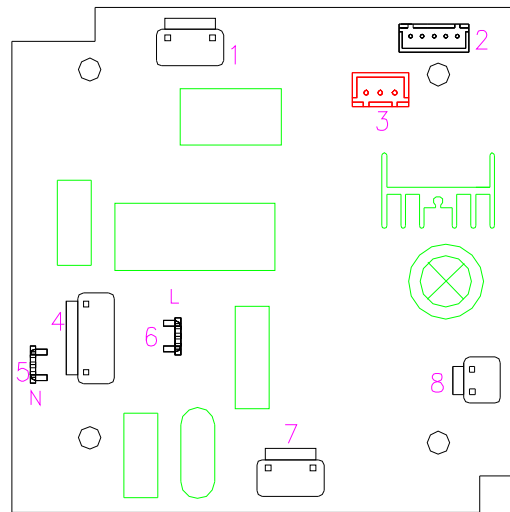

Fig.22

Diagram of the power PCB (Fig.22)

- | | |
|----------------------------------|------------------------------------|
| 1. To PCB heater(white) | 2. To main PCB(white) |
| 3. To out fan (Red) | 4. To compressor |
| 5. Connectors of the power N | 6. Connectors of the power L |
| 7. Transformer primary connector | 8. Transformer secondary connector |

○How to replace the light

1 >. How to replace the bulb

- a. Remove the screw fixing lamp cover(Fig.18),take off the lamp cover(Fig.23).
- b. Remove the bulb according to the direction arrowhead show, replace the bulb(Fig.23.1)

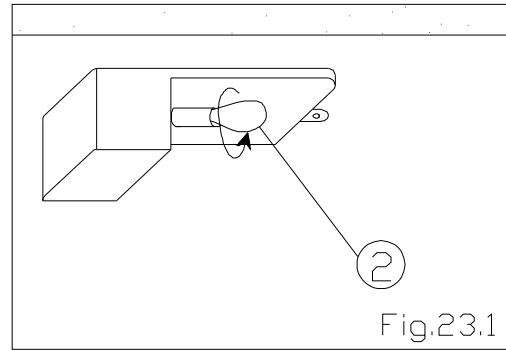
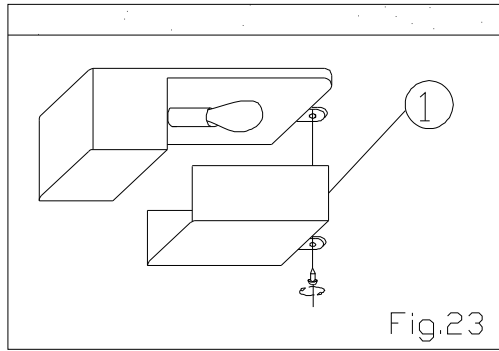

2>. How to replace the LED light

Remove the electrical box,Unplug the LED light connector, press the 4 studs one by one,take the LED light upward,replace it. (Fig.24)

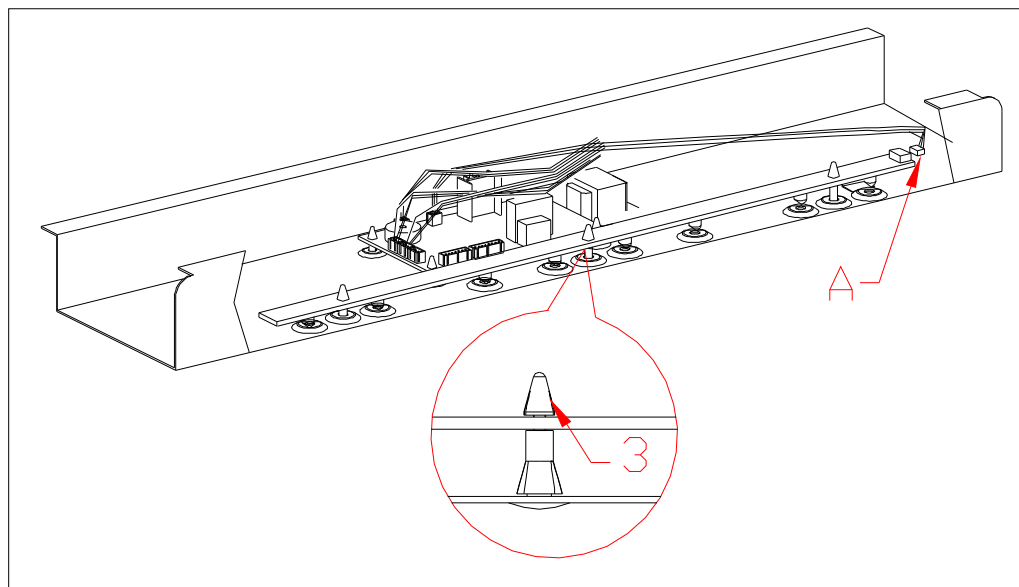

Fig.24

○ How to replace the decorative frame

Remove the screw(1,2,3),pull the decorative frame according to the arrowhead that view K show,then remove the screw(4,5,6) from the gap between decorative frame and cabinet,remove the decorative frame. (Fig.25)

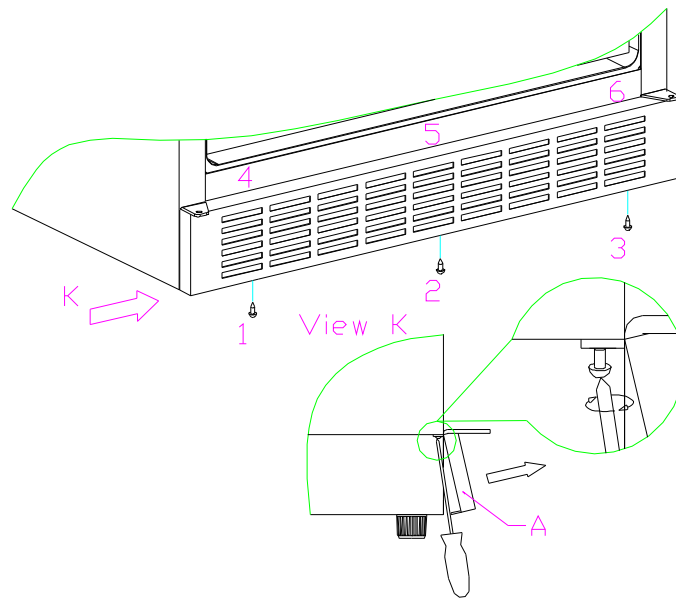

Fig.25