

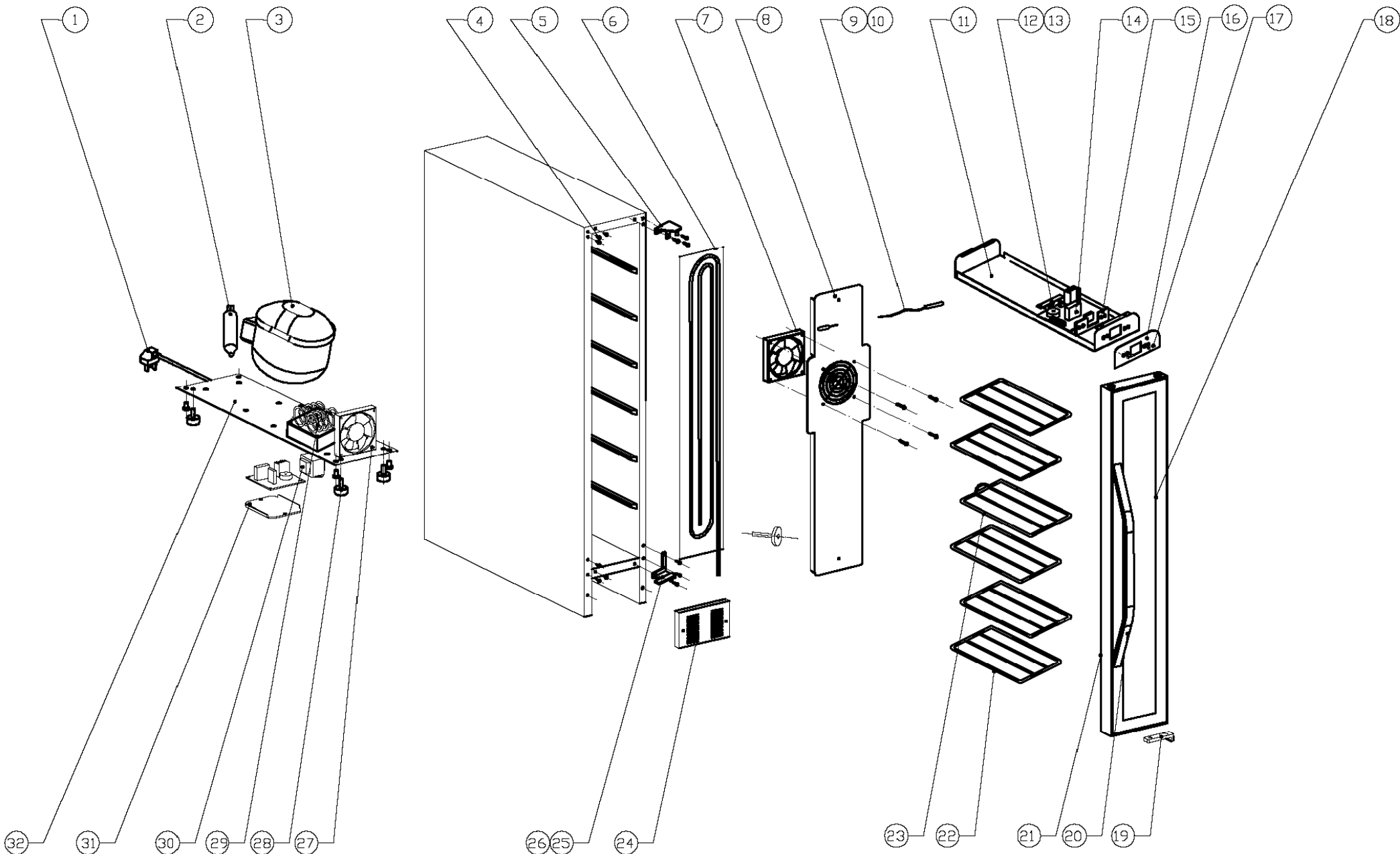

JLWF153

150mm wine cabinet

Technical information



JLWF153
150mm wine cabinet

8 7 6 5 4 4 3 2 1

D
C
B
A



JLWF153 - 150mm wine cabinet

Item	Part Code	Description	Qty
1	DG2-14	Power cord	1
2	DG11-4	Drier filter	1
3	DG1-58	Compressor	1
3	DG12-119	Start Device	1
3	DG12-120	Overload Protector	1
4	DG13-8	Decorative nail	3
4	DG13-268	Decorative nail	3
5	DG14-205-SR	Top hinge module (right)	1
6	DG12-77-1	Evaporator	1
7	DG7-41-BH	Evaporator fan(Upper)	1
8	DG22-397	Air duct board	1
9	DG8-7-W	Senser	1
10	DG8-7-R	Senser	1
11	DG22-396	Electrical box	1
12	DG3-41-W	LED light LED	1
13	DG13-127	LED Light Cover LED	1
14	DG3-42-3	PCB board	1
15	DG13-348	Button gasket	1
16	DG20-205	Display panel	1
17	DG13-130-S	Button	4
19	DG23-225	Cabinet door	1
20	DG22-3073	Stopper	1
21	DG13-407	Handle	1
22	M160-053	Gasket M160	1
23	DG15-139	shelves	5
24	DG15-146	Shelf	1
25	DG22-3108	Decorative frame	1
26	DG14-208-SR	Lower hinge module (right)	1
27	DG22-3057	Lower axis	1
28	DG7-33-BH	Condenser fan	1
29	DG13-6-15	Cabinet legs	4
30	DG12-78	Condenser	1
31	DG6-17	Transformer	1
32	DG22-410	Electrical board cover	1
33	DG22-409	Compressor bracket	1
	DG14-205-SL	Top hinge module (left)	1
	DG14-208-SL	Lower hinge module (left)	1

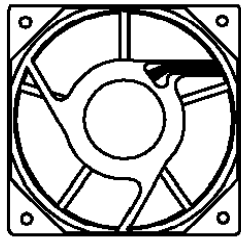

室内风机 inner fan motor

LED灯 LED light

变压器 Transformer

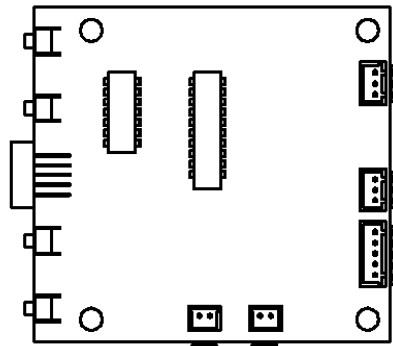

电源线 Power cord

室内感温头 Sensor of inner compartment

接地环 Earth wire ring

除霜感温头 Sensor of Anti-freezer

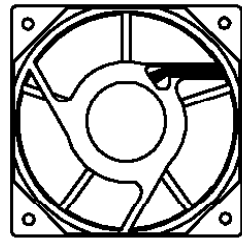

室外风机 outside fan motor

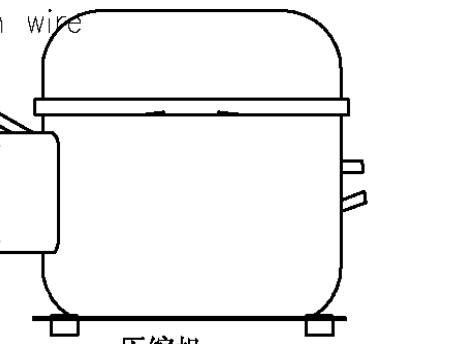

压缩机 Compressor



JLWF153

150mm wine cabinet

8 7 6 5 4 3 2 1

D

C

B

A

A



JLWF153

150mm wine cabinet

