



# **C780G/W**

**Caple 70cm Gas on Glass  
5 Burner Hob White**

**INSTRUCTION MANUAL**

# GENERAL NOTICE



**We invite you to read this instruction booklet carefully, before installing and using the equipment. It is very important that you keep this booklet together with the equipment for any future consultation. If this equipment should be sold or transferred to another person, make sure that the new user receives the booklet, so that he can learn how to operate the appliance and read the corresponding notice.**

- The installation must be carried out by experienced and qualified personnel, in conformity with the regulations in force.
- This equipment has been designed to be used by adults.
- Therefore, make sure that children do not go near the equipment to play with it.
- While the appliance is running, watch the children and make sure they neither stay near the equipment, nor touch the surfaces that have not cooled down completely.
- Before powering the equipment, check that it is properly adjusted for the type of gas at disposal (see the "installation" paragraph).
- Before carrying out the maintenance or cleaning the equipment, cut power supply off and make it cool down.
- Make sure that air circulates around the gas equipment. Insufficient ventilation produces a lack of oxygen.
- In case of an intense or prolonged use of the equipment, it may be necessary to improve aeration, for example by opening a window or increasing the mechanical suction power, if it exists.
- The products of combustion must be discharged outside through a suction hood or an electric fan (see the "installation" paragraph).
- For any possible operation or modification, apply to an authorized Technical Assistance Centre and demand original spare parts.

## SYMBOLS



Do not place anything, e.g. flame tamer, asbestos mat, between pan and pan support as serious damage to the appliance may result.



Do not use large pots or heavy weights which can bend the pan support or deflect the flame onto the hotplate.



Do not remove the pan support and enclose the burner with a wok stand as this will concentrate and deflect the heat onto the hotplate.



Locate pan centrally over the burner so that it is stable and does not overhang the appliance.

***The manufacturer refuses all responsibility for possible damages to things or people, resulting from a wrong installation or from an improper, incorrect or unreasonable use of this equipment.***

# DESCRIPTION AND DIMENSIONS

DIMENSIONS mm		
700x510	600x510	290x510

1 Rapid burner	3000 W	10,8 Mj/h
2 Semi-rapid burner	1650 W	5,9 Mj/h
3 Auxiliary burner	1000 W	3,6 Mj/h
4 Ultra-rapid burner	3300 W	11,9 Mj/h
5 Electric hot plate 145	1500 W	-
6 electric hot plate 180	2000 W	-
8 Control Knob for burner or electric hot plate		

# INSTRUCTIONS FOR THE USER



**IT IS NECESSARY THAT ALL THE OPERATIONS REGARDING THE INSTALLATION, ADJUSTMENT AND ADAPTATION TO THE TYPE OF GAS AVAILABLE ARE CARRIED OUT BY QUALIFIED PERSONNEL, IN CONFORMITY WITH THE REGULATIONS IN FORCE.  
THE SPECIFIC INSTRUCTIONS ARE DESCRIBED IN THE BOOKLET SECTION INTENDED FOR THE INSTALLER**

## USING THE BURNERS

The symbols silk-screen printed on the side of the knob indicate the correspondence between the knob and the burner.

### Start-up without valves

Turn the corresponding knob anticlockwise up to the maximum position (large flame, fig.1) and press start-up button **P** (fig.1).

### Automatic start-up without valves

Turn the corresponding knob anticlockwise up to the maximum position (large flame, fig.1) and press the knob.

### Automatic start-up with valves

Turn the corresponding knob anticlockwise up to the maximum position (large flame, fig.1) and press the knob.

Once the burner has been started up, keep the knob pressed for about 10 seconds.

### Using the burners

In order to obtain the maximum yield without

waste of gas, it is important that the diameter of the pot is suitable for the burner potential (see the following table), so as to avoid that the flame goes out of the pot bottom (fig.2).

Use the maximum capacity to quickly make the liquids reach the boiling temperature, and the reduced capacity to heat food or maintain boiling. All of the operating positions must be chosen between the maximum and the minimum ones, never between the minimum position and the closing point.

The gas supply can be interrupted by turning the knob clockwise up to the closing position.

If there is no power supply, it is possible to light the burners with matches, setting the knob to the start-up point (large flame).

Burners	Power W	ø of pots
Auxiliary	1000	10-14 cm
Semi-rapid	1650	16-18 cm
Rapid	3000	20-22 cm
Ultra-rapid	3300	24-26 cm

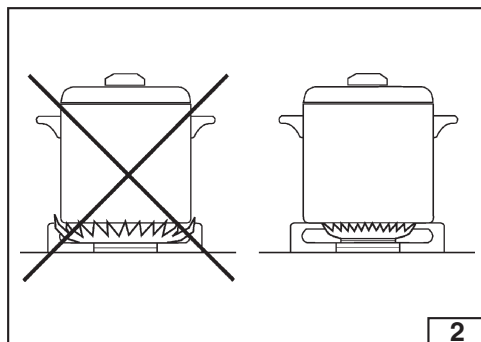
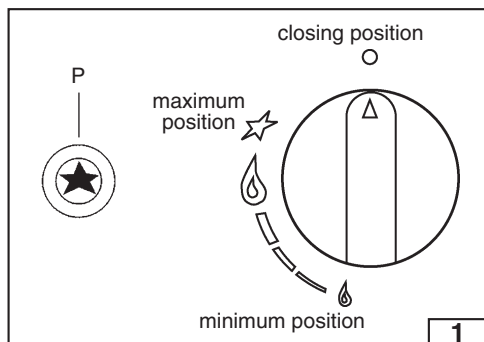

# INSTRUCTIONS FOR THE USER

## USING THE BURNERS

### Notice

- When the equipment is not working, always check that the knobs are in the closing position (see fig.1).
- If the flame should blow out accidentally, the safety valve will automatically stop the gas supply, after a few seconds. To restore operation, set the knob to the lighting point (large flame, fig.1).
- While cooking with fat or oil, pay the utmost attention as these substances can catch fire when overheated.
- Do not use sprays near the appliance in operation.
- Do not place unstable or deformed pots on the burner, so as to prevent them from overturning or overflowing.
- Make sure that pot handles are placed properly.
- When the burner is started up, check that the flame is regular and, before taking pots away, always lower the flame or put it out.

## ELECTRIC PLATE USE

The electric-plate is operated with a seven-position switch and to turn the electric-plate on, rotate the switch to any of the positions shown.

The red light is switched on when the electric-plate is in operation.

Below as indicative basis, the settings to be used for operating the electric-plate.

### Warning

Use only flat pans and with sufficiently thick base, equal or not much superior than that of the plate.

Do not switch the electric plate without the pan over the plate.

Do not cook any food on the plate surface.

Turn off the plate few minutes before the cooking end.

After use the electric plate remains very hot for a prolonged period of time, do not touch it and do not place any object on top of the plate.

For a good preservation, the electric plate must be thoroughly cleaned with appropriate cleaning products which are readily available.

When operating for the first time, it is necessary to eliminate any humidity or oil which may accumulated around the electric elements of the plate by operating the electric plate on its lowest setting (1) for about 30 minutes.

KNOB SETTING	HEAT	TYPE OF COOKING
0	Off	
1	Very low	To heat small quantities of liquids.
2	Low	Heating medium quantities of liquid, to prepare sauces and creams requiring long cooking.
3	Mild	To defrost frozen foods, cook stews, at to below boiling point.
4	Medium	For foods which require boiling point, delicate meat and fish.
5	Strong	For roasting, grilling , stews.
6	Very strong	To boil large quantities of liquid , to fry.

# INSTRUCTIONS FOR THE USER

## **CLEANING**

Before any operation, disconnect the appliance from the electric grid.

It is advisable to clean the appliance when it is cold.

### **Glass platform and enamelled parts**

The glass platform and all of the enamelled parts must be washed with a sponge and soapy water or with a light detergent.

Do not use abrasive or corrosive products.

Do not leave substances, such as lemon or tomato juice, salt water, vinegar, coffee and milk on the enamelled surfaces for a long time.

### **Burners and racks**

These parts can be removed to make cleaning easier.

The burners must be washed with a sponge and soapy water or with a light detergent, wiped well and placed in their housing perfectly. Make sure that the flame-dividing ducts are not clogged.

Check that the feeler of the safety valve and the start-up electrode are always perfectly cleaned, so as to ensure an optimum operation.

The racks can be washed in the dishwasher.

### **Gas taps**

The possible lubrication of the taps must be carried out by specialized personnel, exclusively.

In case of hardening or malfunctions in the gas taps, apply to the Customer Service.

# INSTRUCTIONS FOR THE INSTALLER



## IMPORTANT NOTICE:

THE OPERATIONS INDICATED BELOW MUST BE FOLLOWED BY QUALIFIED PERSONNEL EXCLUSIVELY, IN CONFORMITY WITH THE REGULATIONS IN FORCE.

THE MANUFACTURING FIRM REFUSES ALL RESPONSIBILITY FOR DAMAGES TO PEOPLE, ANIMALS OR THINGS, RESULTING FROM THE FAILURE TO COMPLY WITH SUCH PROVISIONS.

## INSTALLATION

### Installing the top

The appliance is designed to be embedded into heat-resistant pieces of furniture.

The walls of the pieces of furniture must resist a temperature at least a 90°C temperature.

The equipment must not be installed near inflammable materials, such as curtains, cloths, etc.

Make a hole in the top of the piece of furniture, with the dimensions indicated in fig. 3 and in fig. 4, at a distance of at least 50 mm from the appliance border to the adjacent walls.

Any possible wall unit over the cook-top must be placed at a distance of at least 700 mm from the top.

APPLIANCE DIMENSIONS	L (mm)	P (mm)
700 X 510	550	470
600 X 510	550	470
290 X 510	268	490

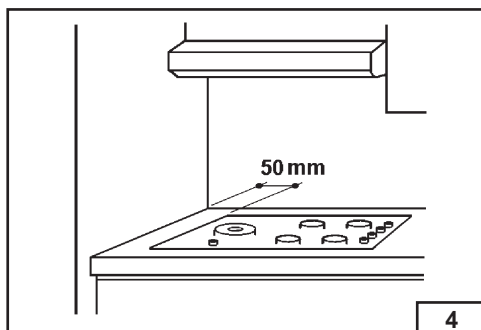
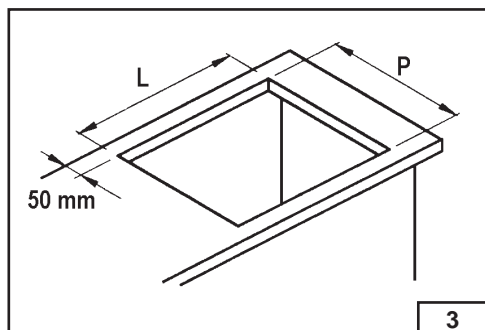

# INSTRUCTIONS FOR THE INSTALLER

## INSTALLATION

### Fastening the top

Every cook-top is equipped with a special washer having an adhesive side.

- Remove the racks and burners from the top.
- Turn the appliance upside down and lay the adhesive washer S along the external border of the glass (fig.5).
- Introduce and place the cook-top in the hole made in the piece of furniture, then block it with the V screws of the fastening hooks G (fig.6).

### Installation room

This appliance is not provided with a device for exhausting the products of combustion.

Regarding room ventilation rules where appliance is installed make reference to the legislation, in conformity with the local regulations.

### FOR THE U.K. ONLY

The room containing this hotplate should have an air supply in accordance with BS 5440: Part 2: 1989.

- All rooms require an openable window, or equivalent and some rooms will require a permanent vent a well.
- For room volumes up to 5 m<sup>3</sup> an air vent of 100 cm<sup>2</sup> is required.
- For room volumes between 5 m<sup>3</sup> and 10 m<sup>3</sup> an air vent of 50 cm<sup>2</sup> is required.
- If the room is greater than 5 m<sup>3</sup> and has a door that opens directly to the outside, then no air vent is required.

If there are other fuel burning appliances in the same room BS 5440: Part 2:1989 should be consulted to determine the air vent requirements.

### Gas connection

Make sure that the appliance is adjusted for the gas type available (see the label under the appliance). Follow the instructions indicated in the chapter "gas transformations and adjustments" for the possible adaptation to different gases. The appliance must be connected to the gas system by means of stiff metal pipes or flexible steel pipes having continuous walls, in compliance with the regulations in force.

Gas enters the appliance through a cylindrical threaded male gas union (1/2").

The connection must not stress the gas ramp.

Once the installation is over, check the connection seal with a soapy solution.

### Electric connection

The connection to the electric grid must be carried out by qualified personnel and in conformity with the regulations in force.

The voltage of the electric system must correspond to the value indicated in the label under the appliance. Make sure that the electric system is provided with an effective ground connection in compliance with the regulations and provisions of the law. Grounding is compulsory. If the appliance is not equipped with a plug, apply a standardized plug to the power supply cable. It is possible to effect the connection to the electric grid directly, by interposing an omnipolar switch having a contact opening distance of at least 3 mm.

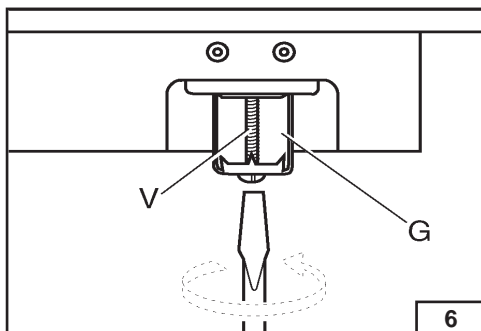
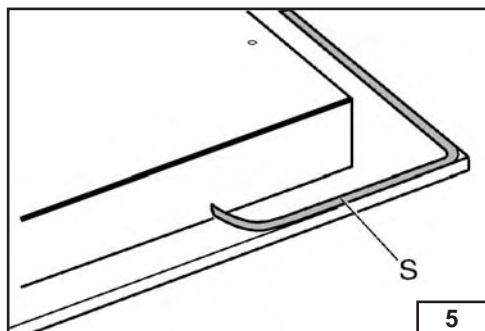

# GAS TRANSFORMATIONS AND ADJUSTMENTS

## GAS TRANSFORMATIONS AND ADJUSTMENTS

### Replacing the nozzles

If the equipment is adjusted for a type of gas that is different from the one available, it is necessary to replace the burner nozzles.

The choice of the nozzles to replace must be made according to the table of the "technical characteristics".

Act as follows:

- Remove the racks and burners.
- by means of a straight spanner L, unscrew the nozzle U (fig.7) and substitute it with the corresponding one.
- tighten the nozzle strongly.

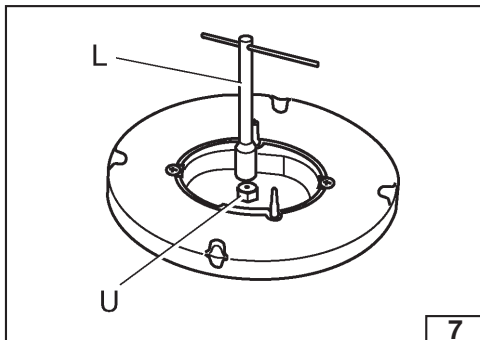

### Adjusting the burners

The lowest flame point must always be properly adjusted and the flame must remain on even if there is an abrupt shift from the maximum to the minimum position.

If this is not so, it is necessary to adjust the lowest flame point as follows:

- start the burner up
- turn the tap up to the minimum position (small flame)
- remove the knob from the tap rod
- introduce a flat-tip screwdriver C in the hole F of the tap (fig.8) and turn the by-pass screw up to a proper adjustment of the lowest flame point.

As regards G 30 gas burners, the by-pass screw must be tightened completely.

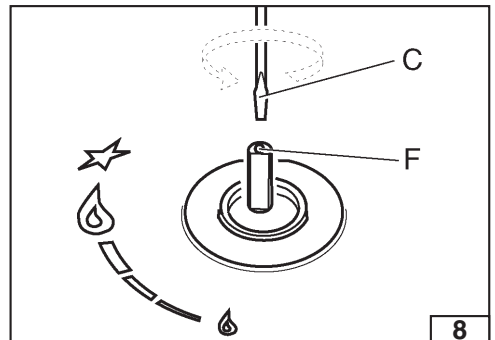

# MAINTENANCE

## MAINTENANCE

### Lubricating the taps

In case of tap hardening, it is necessary to disassemble and grease it.

These are the operations to carry out:

- Unscrew the two screws that lock the head flange of the tap.
- Lift the gas adjusting cone and carefully clean it with gasoline or diluent.
- Spread a little high-temperature grease on it, making sure that the gas holes are not obstructed.
- Reassemble all of the parts with care.

### Replacing the power supply cable

If the power supply cable should be replaced, it is necessary to use a cable with a section of 3 x 0.75 mm<sup>2</sup>, type HO5VV-F or H05RR-F, complying with the regulations in force.

The connection to the terminal board must be effected as shown in fig. 9:

brown cable	L	(phase)
blue cable	N	(neutral)
green-yellow cable		(ground)

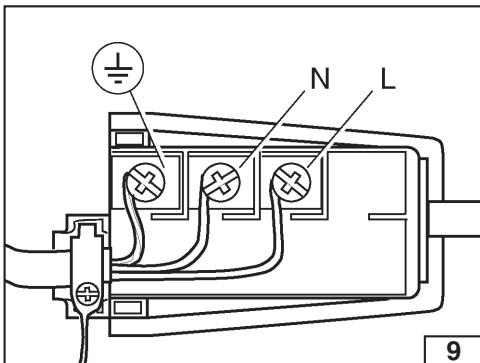

# TECHNICAL CHARACTERISTIC TABLES

BURNERS		GAS	NORMAL PRESSURE mbar	NOMINAL RATE		INJECTOR DIAMETER 1/100 mm	TAPE BY PASS DIAMETER 1/100 mm	NOMINAL HEAT INPUT (WATT)	
N°	DESCRIPTION			g/h	L/h			Max.	Min.
1	RAPID	G30	30	218	-	85	40	3000	900
		G31	37	214	-	85	40	3000	900
		G20	20	-	274	128	Reg.	3000	900
		G25	25	-	322	132	Reg.	3000	900
2	SEMI-RAPID	G30	30	120	-	65	29	1650	600
		G31	37	118	-	65	29	1650	600
		G20	20	-	154	94	Reg.	1650	600
		G25	25	-	179	100	Reg.	1650	600
3	AUXILIARY	G30	30	73	-	50	27	1000	450
		G31	37	72	-	50	27	1000	450
		G20	20	-	95	76	Reg.	1000	450
		G25	25	-	107	80	Reg.	1000	450
4	ULTRA-RAPID	G30	30	240	-	92	60	3300	1850
		G31	37	236	-	92	60	3300	1850
		G20	20	-	312	139	Reg.	3300	1850
		G25	25	-	312	139	Reg.	3300	1850

BURNERS		GAS	NOMINAL PRESSURE Kpa	INJECTOR DIAMETER 1/100 mm	NOMINAL HEAT IMPUT (MJ/h)	
N°	DESCRIPTION				Max.	Min.
1	RAPID	NATURAL U-LPG	1,0	1,55	10,8	3,20
			2,75	0,85	10,8	3,50
2	SEMI-RAPID	NATURAL U-LPG	1,0	1,10	5,90	1,00
			2,75	0,65	5,90	1,30
3	AUXILIARY	NATURAL U-LPG	1,0	0,90	4,00	1,00
			2,75	0,50	3,80	0,80
4	WOK	NATURAL U-LPG	1,0	1,60	11,90	5,00
			2,75	0,95	11,90	5,30

## **This product complies with EU Directive 2002/96/EC.**

The crossed-out dustbin symbol reported on the appliance indicates that the appliance must be disposed of separately from other domestic refuse at the end of its useful life. It must therefore be delivered to a waste recycling centre specifically for electric and electronic equipment or returned to the retailer at the moment of purchase of a new equivalent appliance.



The user is responsible for delivering the appliance to the appropriate collection centre at the end of its useful life. Failure to do so may result in a fine, as provided for by laws governing waste disposal.

Differential collection of waste products for eventual recycling, treatment and environmentally friendly disposal helps reduce possible negative effects on the environment and health, and also enables the materials making up the product to be recycled.

For more detailed information on the available refuse collection systems, refer to the local Municipal Solid Waste disposal centre or the shop where the product was purchased.

Producers and importers are responsible for fulfilling their obligations as regards recycling, treatment and environmentally friendly disposal by directly or indirectly participating in the collection system.

The manufacturing firm refuses all responsibility for any possible imprecision in this booklet, due to misprints or clerical errors. It reserves the right to make all the changes that it will consider necessary in its own products, without affecting the essential characteristics of functionality and safety.