



C751G/SS

Caple 70cm 5 Burner Gas Hob
Stainless Steel



INSTRUCTION MANUAL

GENERAL NOTICE



We invite you to read this instruction booklet carefully, before installing and using the equipment. It is very important that you keep this booklet together with the equipment for any future consultation. If this equipment should be sold or transferred to another person, make sure that the new user receives the booklet, so that he can learn how to operate the appliance and read the corresponding notice.

THIS APPLIANCE COMPLIES WITH THE FOLLOWING DIRECTIVES :

EEC 90/396	(Gas)
EEC 73/23 and 93/88	(Low Voltage)
EEC 89/336	(Electromagnetic Compatibility)
EEC 89/109	(Contact with foods)

- The installation must be carried out by experienced and qualified personnel, in conformity with the regulations in force.
 - This equipment has been designed to be used by adults.
 - Therefore, make sure that children do not go near the equipment to play with it.
 - While the appliance is running, watch the children and make sure they neither stay near the equipment, nor touch the surfaces that have not cooled down completely.
 - Before powering the equipment, check that it is properly adjusted for the type of gas at disposal (see the "installation" paragraph).
 - Before carrying out the maintenance or cleaning the equipment, cut power supply off and make it cool down.
 - Make sure that air circulates around the gas equipment. Insufficient ventilation produces a lack of oxygen.
 - In case of an intense or prolonged use of the equipment, it may be necessary to improve aeration, for example by opening a window or increasing the mechanical suction power, if it exists.
 - The products of combustion must be discharged outside through a suction hood or an electric fan (see the "installation" paragraph).
 - For any possible operation or modification, apply to an authorized Technical Assistance Centre and demand original spare parts.
-
-

The manufacturer refuses all responsibility for possible damages to things or people, resulting from a wrong installation or from an improper, incorrect or unreasonable use of this equipment.

DESCRIPTION AND DIMENSIONS

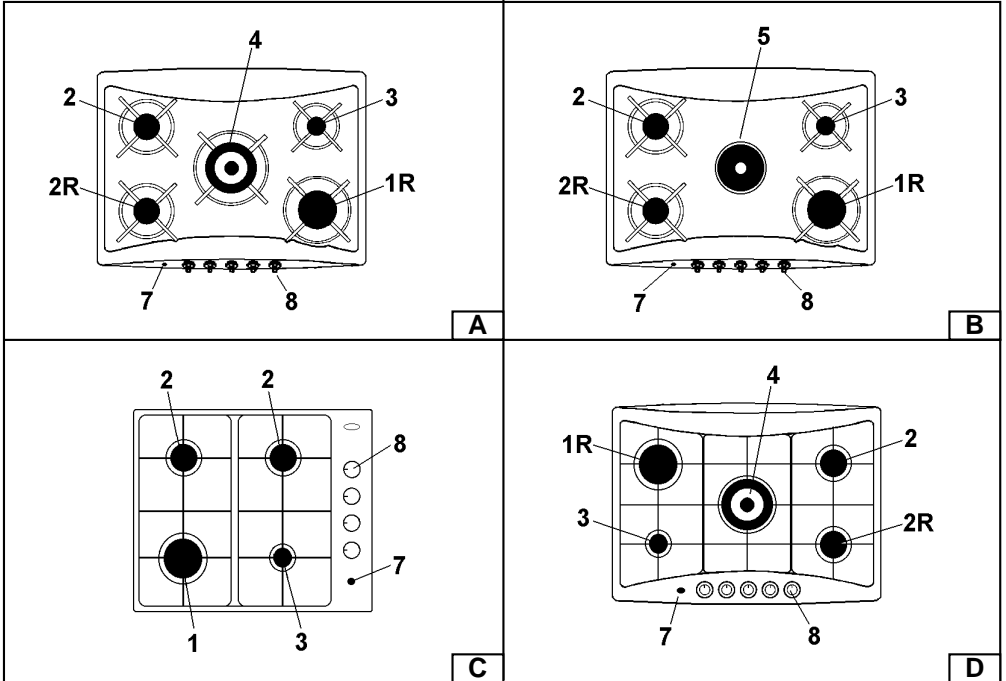

1	Rapid burner	2900W
1R	Rapid burner	2600W
2	Semi-rapid burner	1650W
2R	Semi-rapid burner	1400W
3	Auxiliary burner	1000W
4	Triple ring burner	3500W
5	Electric hot plate	1500W
7	Electric ignition button	
8	Control knobs for gas and electric hot plates	

INSTRUCTIONS FOR THE USER



IT IS NECESSARY THAT ALL THE OPERATIONS REGARDING THE INSTALLATION, ADJUSTMENT AND ADAPTATION TO THE TYPE OF GAS AVAILABLE ARE CARRIED OUT BY QUALIFIED PERSONNEL, IN CONFORMITY WITH THE REGULATIONS IN FORCE. THE SPECIFIC INSTRUCTIONS ARE DESCRIBED IN THE BOOKLET SECTION INTENDED FOR THE INSTALLER

USING THE BURNERS

The symbols silk-screen printed on the side of the knob indicate the correspondence between the knob and the burner.

Manual ignition

Press the knob and turn it anticlockwise until it reaches the  symbol on the control panel (maximum flame position) and place a lighted match or lighter near the burner.

Electrical ignition

Press the knob and turn it anticlockwise until it reaches the  symbol on the control panel (maximum flame position) and press the button on the control panel.

Automatic electrical ignition

Press the knob and turn it anticlockwise until it reaches the  symbol on the control panel (maximum flame position) and then depress the knob.

On those models fitted with a safety device, the knob must be pressed in for about 6 seconds once the burner has ignited.

Using the burners

In order to obtain the maximum yield without waste of gas, it is important that the diameter of the pot is suitable for the burner potential (see the following table), so as to avoid that the flame goes out of the pot bottom (fig.1).

Use the maximum capacity to quickly make the liquids reach the boiling temperature, and the reduced capacity to heat food or maintain boiling. All of the operating positions must be chosen between the maximum and the minimum ones, never between the minimum position and the closing point.

The gas supply can be interrupted by turning the knob clockwise up to the closing position.

Burners	Power W	ø of pots
Auxiliary	1000	10-14 cm
Semi-rapid	1400/1650	16-18 cm
Rapid	2600/2900	20-22 cm
Ultra-rapid	3500	24-26 cm

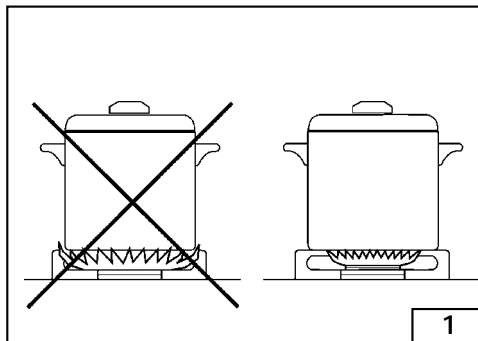

INSTRUCTIONS FOR THE USER

USING THE BURNERS

Notice

- When the equipment is not working, always check that the knobs are in the closing position (●).
- While cooking with fat or oil, pay the utmost attention as these substances can catch fire when overheated.
- Do not use sprays near the appliance in operation.
- Do not place unstable or deformed pots on the burner, so as to prevent them from overturning or overflowing.
- Make sure that pot handles are placed properly.
- When the burner is started up, check that the flame is regular and, before taking pots away, always lower the flame or put it out.

ELECTRIC PLATE USE

The electric-plate is operated with a seven-position switch and to turn the electric-plate on, rotate the switch to any of the positions shown.

The red light is switched on when the electric-plate is in operation.

Below as indicative basis, the settings to be used for operating the electric-plate.

Warning

Use only flat pans and with sufficiently thick base, equal or not much superior than that of the plate.

Do not switch the electric plate without the pan over the plate.

Do not cook any food on the plate surface.

Turn off the plate few minutes before the cooking end.

After use the electric plate remains very hot for a prolonged period of time, do not touch it and do not place any object on top of the plate.

For a good preservation, the electric plate must be thoroughly cleaned with appropriate cleaning products which are readily available.

When operating for the first time, it is necessary to eliminate any humidity or oil which may accumulated around the electric elements of the plate by operating the electric plate on its lowest setting (1) for about 30 minutes.

KNOB SETTING	HEAT	TYPE OF COOKING
0	Off	
1	Very low	To heat small quantities of liquids.
2	Low	Heating medium quantities of liquid, to prepare sauces and creams requiring long cooking.
3	Mild	To defrost frozen foods, cook stews, at to below boiling point.
4	Medium	For foods which require boiling point, delicate meat and fish.
5	Strong	For roasting, grilling , stews.
6	Very strong	To boil large quantities of liquid , to fry.

INSTRUCTIONS FOR THE USER

CLEANING

Before any operation, disconnect the appliance from the electric grid.

It is advisable to clean the appliance when it is cold.

Enamelled parts

The enamelled parts must be washed with a sponge and soapy water or with a light detergent.

Do not use abrasive or corrosive products.

Do not leave substances, such as lemon or tomato juice, salt water, vinegar, coffee and milk on the enamelled surfaces for a long time.

Stainless steel parts

Stainless steel can be stained if it remains in contact with highly calcareous water or aggressive detergents for an extended period of time.

The stainless steel parts should also be cleaned with soapy water and then dried with a soft cloth.

Burners and racks

These parts can be removed to make cleaning easier.

The burners must be washed with a sponge and soapy water or with a light detergent, wiped well and placed in their housing perfectly. Make sure that the flame-dividing ducts are not clogged.

Check that the feeler of the safety valve and the start-up electrode are always perfectly cleaned, so as to ensure an optimum operation.

The racks can be washed in the dishwasher.

Gas taps

The possible lubrication of the taps must be carried out by specialized personnel, exclusively.

In case of hardening or malfunctions in the gas taps, apply to the Customer Service.

INSTRUCTIONS FOR THE INSTALLER



IMPORTANT NOTICE

THE OPERATIONS INDICATED BELOW MUST BE FOLLOWED BY QUALIFIED PERSONNEL EXCLUSIVELY, IN CONFORMITY WITH THE REGULATIONS IN FORCE. THE MANUFACTURING FIRM REFUSES ALL RESPONSIBILITY FOR DAMAGES TO PEOPLE, ANIMALS OR THINGS, RESULTING FROM THE FAILURE TO COMPLY WITH SUCH PROVISIONS.

INSTALLATION

Installation room

This appliance is not provided with a device for exhausting the products of combustion. Therefore, it is necessary to discharge these smokes outside.

The room where this appliance is installed must have a natural air inflow, so as to ensure a regular gas combustion and room ventilation: the necessary air volume must not be lower than 20 m³.

In rooms less than 20 m³ air must come from permanent openings made on the room walls that communicate with the outside.

The section of these openings shall correspond to at least 200 cm².

Installing the top

The appliance is designed to be embedded into heat-resistant pieces of furniture.

The walls of the pieces of furniture must resist a temperature of 75°C besides the room one.

The gas hobs are equipped with type X degree protection against overheating. Therefore, the appliance can be installed next to cabinets, provided the height of the cabinet does not exceed that of the hob.

The equipment must not be installed near inflammable materials, such as curtains, cloths, etc. Make a hole in the top of the piece of furniture, with the dimensions indicated in fig.2, at a distance of at least 50 mm from the appliance border to the adjacent walls.

Any possible wall unit over the cook-top must be placed at a distance of at least 760 mm from the top.

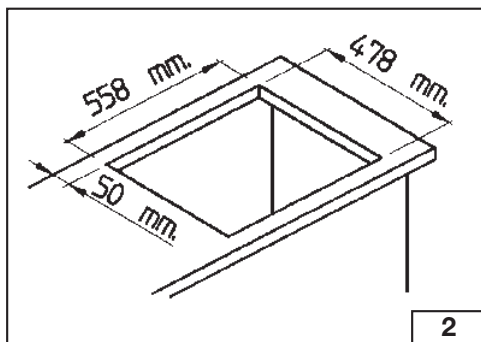

INSTRUCTIONS FOR THE INSTALLER

INSTALLATION

Fastening the top

Every cook-top is equipped with a special washer having.

This must be placed under the edge of the box unit, as close as possible to the edge itself.

With 70 mm hob, hooks must be placed, with suitable screws V to the box unit.(fig. 3).

Introduce and place the cook-top in the hole made in the piece of furniture, then block it with the screws of the fastening hooks C (fig. 4 or 5).

Gas connection

Make sure that the appliance is adjusted for the gas type available (see the label under the appliance). Follow the instructions indicated in the chapter "gas transformations and adjustments" for the possible adaptation to different gases. The appliance must be connected to the gas system by means of stiff metal pipes or flexible steel pipes having continuous walls, in compliance with the regulations in force.

Gas enters the appliance through a cylindrical

threaded male gas union (1/2").

The connection must not stress the gas ramp.

Once the installation is over, check the connection seal with a soapy solution.

Electric connection

The connection to the electric grid must be carried out by qualified personnel and in conformity with the regulations in force.

The voltage of the electric system must correspond to the value indicated in the label under the appliance. Make sure that the electric system is provided with an effective ground connection in compliance with the regulations and provisions of the law. Grounding is compulsory. If the appliance is not equipped with a plug, apply a standardized plug to the power supply cable.

It is possible to effect the connection to the electric grid directly, by interposing an omnipolar switch having a contact opening distance of at least 3 mm.

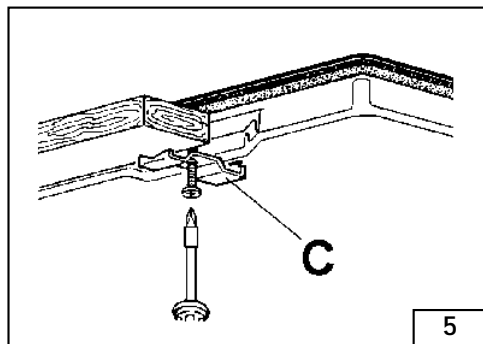
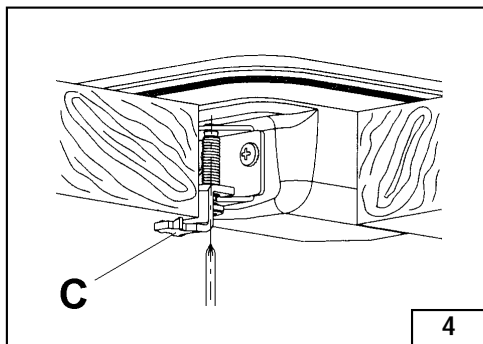
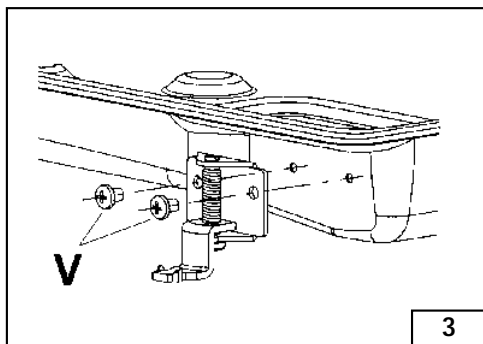

GAS TRANSFORMATIONS AND ADJUSTMENTS

GAS TRANSFORMATIONS AND ADJUSTMENTS

Replacing the nozzles

If the equipment is adjusted for a type of gas that is different from the one available, it is necessary to replace the burner nozzles.

The choice of the nozzles to replace must be made according to the table of the "technical characteristics".

Act as follows:

- Remove the racks and burners.
- by means of a straight spanner L, unscrew the nozzle U (fig.6) and substitute it with the corresponding one.
- tighten the nozzle strongly.

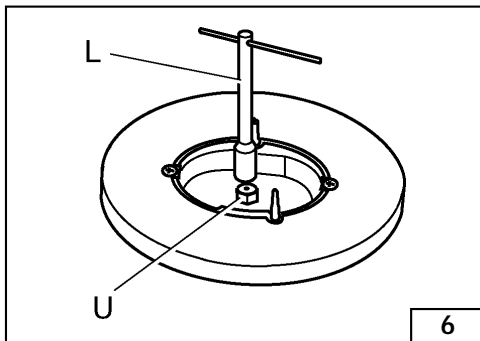

Adjusting the burners

The lowest flame point must always be properly adjusted and the flame must remain on even if there is an abrupt shift from the maximum to the minimum position.

If this is not so, it is necessary to adjust the lowest flame point as follows:

- start the burner up
- turn the tap up to the minimum position (small flame)
- remove the knob from the tap rod
- introduce a flat-tip screwdriver C in the hole F or near the tap rod (fig. 7-7A) and turn the by-pass screw up to a proper adjustment of the lowest flame point.

As regards G 30 gas burners, the by-pass screw must be tightened completely.

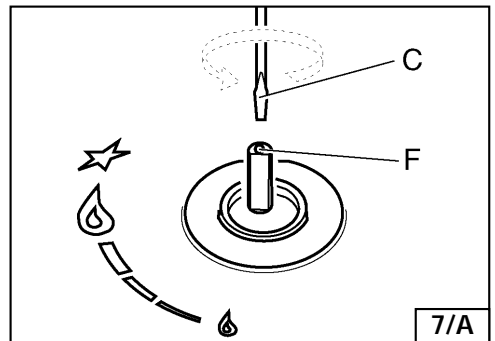
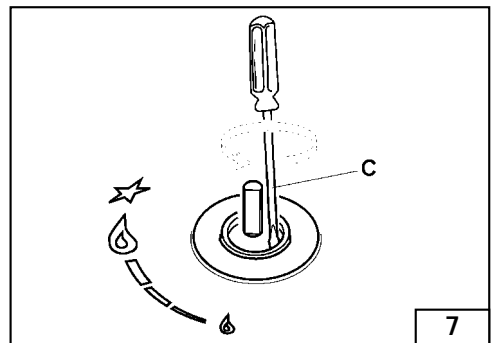

MAINTENANCE

MAINTENANCE

Lubricating the taps

In case of tap hardening, it is necessary to disassemble and grease it.

These are the operations to carry out:

- Unscrew the two screws that lock the head flange of the tap.
- Lift the gas adjusting cone and carefully clean it with gasoline or diluent.
- Spread a little high-temperature grease on it, making sure that the gas holes are not obstructed.
- Reassemble all of the parts with care.

Replacing the power supply cable

If the power supply cable should be replaced, it is necessary to use a cable with a section of 3×0.75 mm², type HO5VV-F or H05RR-F, complying with the regulations in force.

The connection to the terminal board must be effected as shown in fig. 9:

brown cable	L	(phase)
blue cable	N	(neutral)
green-yellow cable		(ground)

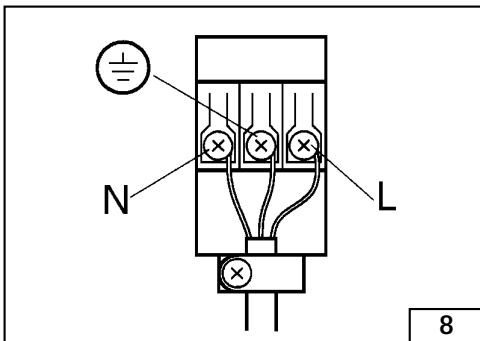

TECHNICAL CHARACTERISTIC TABLES

BURNERS		GAS	NORMAL PRESSURE mbar	NOMINAL RATE		INJECTOR DIAMETER 1/100 mm	INJECTOR DIAMETER 1/100 mm	NOMINAL HEAT INPUT (WATT)	
N°	DENOMINAZIONE			g/h	L/h			Max.	Min.
1	RAPID	G30 - G31 G20	28 - 30 20	218 -	- 274	85 128	40 Reg.	2900 2900	950 950
1R	RAPID	G30 - G31 G20	28 - 30 20	189 -	- 247	80 117	40 Reg.	2600 2600	950 950
2	SEMI-RAPID	G30 - G31 G20	28 - 30 20	120 -	- 154	65 94	29 Reg.	1650 1650	600 600
2R	SEMI-RAPID	G30 - G31 G20	28 - 30 20	102 -	- 131	60 86	30 Reg.	1400 1400	600 600
3	AUXILIARY	G30 - G31 G20	28 - 30 20	73 -	- 95	50 76	27 Reg.	1000 1000	450 450
4	ULTRA-RAPID	G30 - G31 G20	28 - 30 20	254 -	- 333	90 + 37 121 + 63	60 Reg.	3500 3500	1500 1500

DESCRIPTION (pag. 4)	A - D	B	C
CATEGORY	II 2H3+	II 2H3+	II 2H3+
GAS RATES	738 g/h 10,15 kW	484 g/h 6,65 kW	531 g/h 7,2 kW
VOLTAGE	230 V. ~ 50 Hz	230 V. ~ 50 Hz	230 V. ~ 50 Hz
POWER RATING	-	1500 W	-

The manufacturing firm refuses all responsibility for any possible imprecision in this booklet, due to misprints or clerical errors. It reserves the right to make all the changes that it will consider necessary in its own products, without affecting the essential characteristics of functionality and safety.