



WDU050

Caple Waste Disposal Unit



Technical information

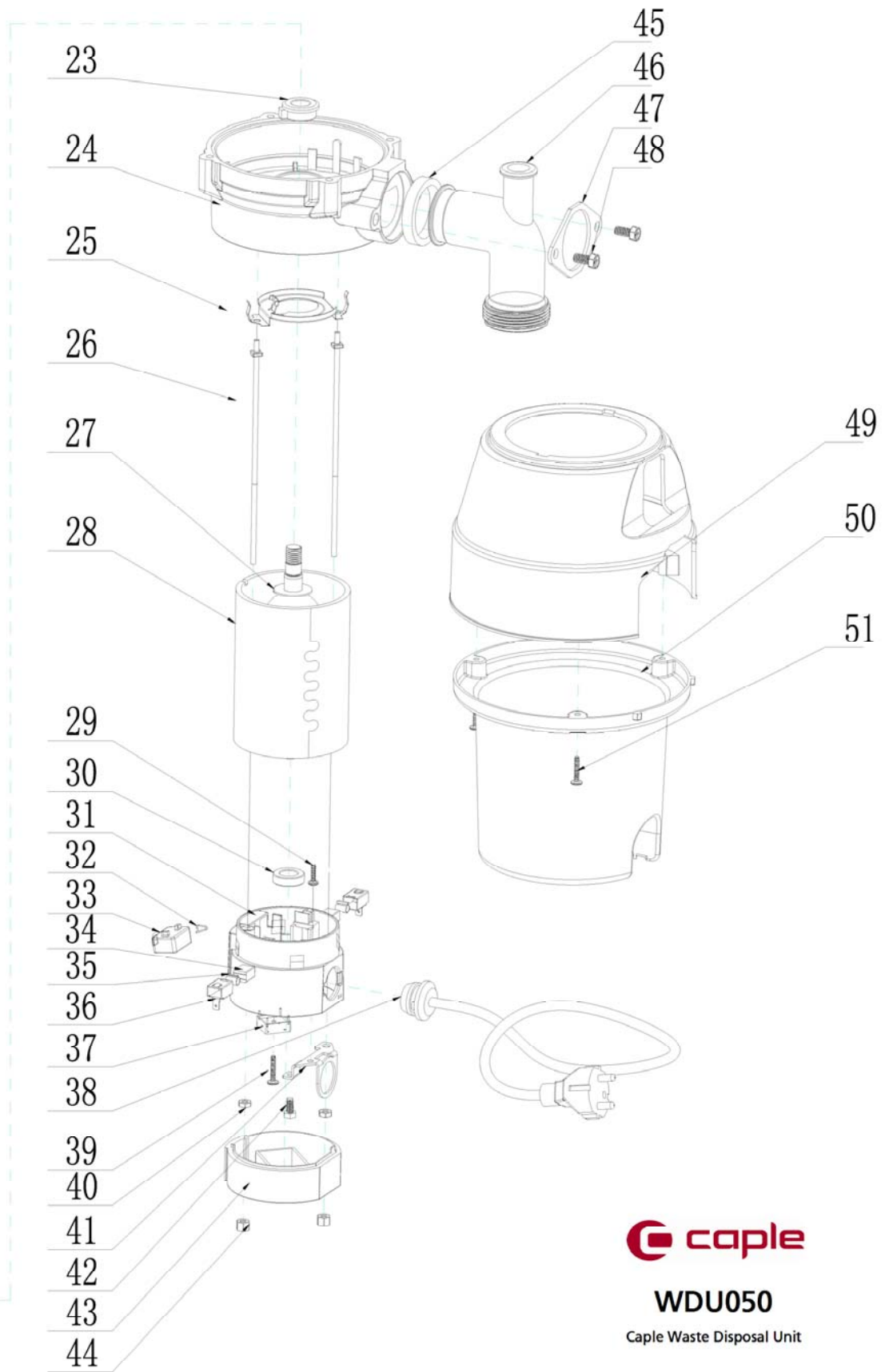
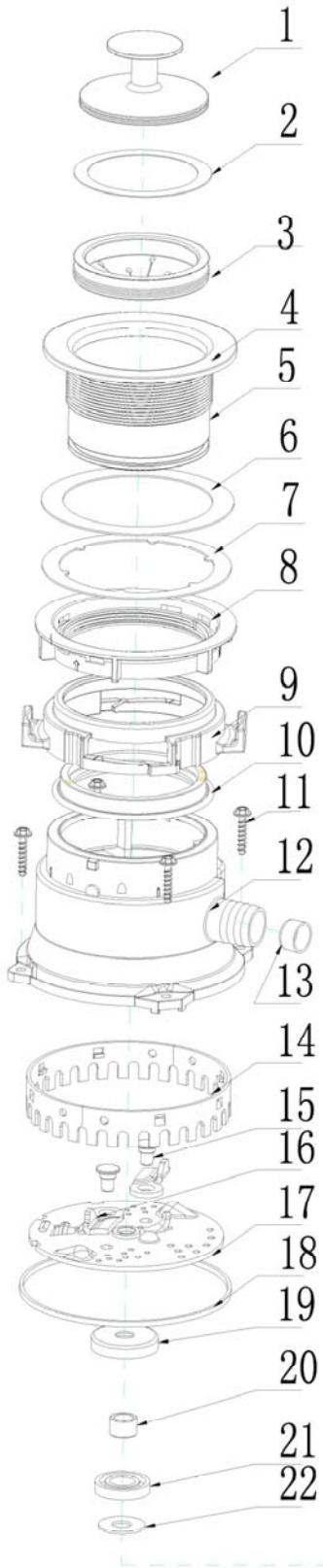

caple

WDU050

Caple Waste Disposal Unit



WDU050 - Caple Waste Disposal Unit

Item	Part Code	Description	Qty
1	660820600002	Stoper	1
2	660920300002	Stoper seal ring	1
3	660920600000	Splash guard	1
4	660620200001	Sink Flange Steel	1
5	660820700000	Sink Flange Body	1
6	660920200000	Rubber Sink Flange Gasket	1
7	660521900000	Fiber Gasket	1
8	660820900000	Support Ring	1
9	660620300000	Mount Ring	1
10	660920100000	Cushion Mount	1
11	660520100000	Grinding Chamber Screw	4
12	660820400001	Upper Grinding Chamber	1
13	660820600001	DW Discharge Inlet Plug	1
14	660620700001	Grinding Ring	2
15	660521500000	Rivet	2
16	660620800001	Swivel impeller	2
17	660620900001	Turntable	1
18	660920300000	Waterproof ring	1
19	660620600001	Shaft Cover	1
20	660523200000	Shaft Ring	1
21	660523000000	Oil Seal	1
22	660620400000	Metal Ring (Grinding Chamber)	1
23	660523100000	Oiliness bearing(Up)	1
24	660820500000	Lower Grinding Chamber	1
25	660620600000	Asphalt Felt Mud Cover	1
26	660520400005	Motor Long Double Screw	2
27	660620400001	Metal Ring(Shaft Ring)	1
28	662820600004	Motor ASM	1
29	660520200000	Tension Plate Screw	1
30	660523100001	Oiliness Bearing(Lower)	1
31	660821100004	Bottom Plate	1
32	660520500000	Proctector Bracket	1
33	660720400004	Protector	1
34	660720300001	Carbon Brush	2
35	660520500001	Carbon Brush Spring	2
36	660620500001	Carbon Brush Bracket	2
37	660720020602	Bridge Rectifier	1
38	660720700005	Power cord	1
39	660520300000	Cooling Plate Screw	1
40	660521000000	Screw Nut(3.2)	2
41	660620500000	Tension Plate	1



WDU050 - Caple Waste Disposal Unit

Item	Part Code	Description	Qty
42	660520100002	Grounding Screw	1
43	660400400001	lower cover	1
44	660521000001	Screw Nut(6.5)	2
45	660920300001	Drainpipe Seal Ring	1
46	660821000001	Drainpipe	1
47	660620600003	Drainpipe Plate	1
48	660520100001	Drainpipe Screw	2
49	660820100012	Upper Shell	1
50	660820100013	Lower Shell	1
51	660520300000	Cooling Plate Screw	3



Wiring diagram for Caple Waste Disposal Units

220~240V/50HZ

