



Waste Disposal Unit Instruction Manual

WDU050



Contact Caple on 0117 938 7420 for spare parts or www.caple.co.uk

CONTENTS

Safety Information	4
Electrical Connection	8
Installation Instructions	12
Dimensions	18
Operating Instructions	19
Care and Maintenance	21
Troubleshooting	21
Caple Contact Details	24

INSTRUCTIONS

Read these instructions carefully and completely before using your Waste Disposal Unit, keep it in a convenient place for reference when necessary.

NOTE: This Waste Disposal Unit has been designed to operate at 220/240V~, 50/60 Hz household current exclusively. Using any other voltage or Hz adversely affects performance, and invalidates the warranty.

CAUTION: Be sure to review the Safety Instructions Warning and Electrical Connection section before using disposer.

NOTE:

Model information and serial number appears on the rating label affixed to bottom of the disposer. For your convenience, write down the model and serial numbers prior to installation.

SAFETY INSTRUCTIONS

Instructions pertaining to a risk of fire, electric shock or injury to persons. Save these instructions.

WARNING:

- Use this appliance only for its intended purpose, as described in this instruction manual. Read all instructions before using the waste disposal unit.
- To reduce the risk of injury, close supervision is required when an appliance is in use near children.
- DO NOT put your fingers or hands into the waste disposer.
- If the appliance becomes jammed or an object is stuck, turn off the power at the mains before attempting to remove it.
- When attempting to loosen a jam, use a long wooden object such as a wooden spoon.
- When attempting to remove objects from a waste disposer, use non-magnetic long handled tongs instead of pliers.
- To reduce the risk of materials being expelled when in use and causing harm, do not put the following in the disposer:
 1. Clam or oyster shells.
 2. Caustic drain cleaners or similar.
 3. Glass, china or plastic.

4. Large whole bones.
 5. Metal such as bottle caps, tin cans, utensils or aluminum foil.
 6. Hot grease or other hot liquids.
 7. Whole corn husks.
- This appliance must be installed in accordance to local laws and standards. We recommend using a qualified installer.
 - Do not disassemble the appliance for any reason, there are no serviceable parts.
 - When not using the disposer we recommend leaving the stopper in place to help prevent items falling in.
 - The appliance must be installed ensuring the reset button is readily accessible.
 - This appliance is not intended for use by persons (including children) with reduced physical, sensory or mental capabilities or lack of experience and knowledge, unless they have been given supervision or instruction concerning the use of the appliance by a person responsible for their safety.
 - Children should be supervised to ensure they do not play with the appliance.
 - If the supply cord becomes damaged, it must be replaced by a Caple engineer or a similiary qualified person in order to avoid a hazard.
 - Make sure the installation of this appliance is allowed by the local authorities.

- For correct earthing instructions please see the 'Electrical connection' section of this manual.
- Never use this appliance in a damp location (for example a bathroom or laundry room)
- Do not use this appliance to dispose of hard materials such as glass or metal.
- Switch off or unplug the appliance before attempting to free a jammed rotor.



ENVIRONMENTAL PROTECTION

Waste electrical products should not be disposed of with household waste. Please recycle where facilities exist. Check with your Local Authority or retailer for recycling advice. This appliance is marked according to the European Directive on Waste Electrical and Electronic Equipment (WEEE).

By ensuring this product is disposed of correctly, you will help prevent potential negative consequences for the environment and human health, which could otherwise be caused by inappropriate waste handling of this product. The symbol on the product indicates that this product may not be treated as household waste. Instead it shall be handed over to the applicable collection point for the recycling of electrical and electronic equipment. Disposal must be carried out in accordance with local environmental regulations for waste disposal.

For more detailed information about treatment, recovery and recycling of this product, please contact your local council, your household waste disposal service or the retailer where you purchased the product.

CE DECLARATIONS OF CONFORMITY



This appliance has been manufactured to the strictest standards and complies with all applicable legislation, Low Voltage Directive (LVD) and Electromagnetic Compatibility (EMC).

UKCA DECLARATIONS OF CONFORMITY



This appliance has been manufactured to the strictest standards and complies with all applicable legislation.

WARRANTY

Your new appliance is covered by warranty. The warranty card is enclosed - if it is missing, you must provide the following information to your retailer in order to receive a replacement: date of purchase, model and serial number. Registration can also be completed online by visiting www.caple.co.uk.

ELECTRICAL CONNECTION

If you are not familiar with electrical installations and procedures, please contact a qualified electrician.

DANGER

An incorrect earth connection can result in a risk of electric shock. Check with a qualified electrician if you are in doubt as to whether the waste disposal unit is correctly earthed. Do not modify the plug provided with the appliance, if it will not fit in the socket have a correct connection installed by a qualified electrician.

These appliances are meant for household use, do not use in a commercial application.

EARTHING INSTRUCTIONS

This appliance must be earthed. In the event of a malfunction or breakdown earthing provides a path of least resistance for the electric current to reduce the risk of electric shock. This appliance is equipped with a cord having an equipment earthing conductor and earthed plug. The plug must be plugged into an appropriate socket that is correctly installed and earthed in accordance with the local codes and ordinances.

If you are not familiar with electrical power and procedures, call a qualified electrician.

The power cord and/or connections must comply with local codes and ordinances.

FOR MODELS NOT EQUIPPED WITH A CORD:

- › Choose a power cord not less than H 05V V-F, 3G1.0mm incorporate with a plug rated 250V 13A (fuse in plug:250V,10A) approved by BSI with matched ground wire for the UK market (Standard: BS1363-1) or a plug rated 250V 16A approved by VDE with matched ground wire (Standard: DINVDE0620-1).
- › Chose a power cord not less than H05VV-F, 3G1.0mm and fitted with a switch, the switch shall be directly connected to the supply terminals and shall have a contact separation in all poles, providing full disconnect under overvoltage category III conditions (the full disconnection not less than 3mm).
- › Make sure the switch is easily visible and accessible. The recommend distance between this appliance and electrical switch is within 2m.

DANGER:

Improper connection of the equipment-grounding conductor can result in a risk of electric shock. Check with a qualified electrician if you are in doubt as to whether the appliance is properly grounded.

NOTE:

Disconnect the electric power to disposer circuit before installation. Turn the circuit breaker to the OFF position or remove the fuse.

- A. Connect the disposer to 220-240 Volt, 50-60 Hz AC current only.
- B. If a plug-in cord is used, use a three-prong plug. A earth wire should be attached to the ground screw in the bottom of the disposer (end bell). Follow the lead connected to this blade marked with a 'L' and attach that lead to the blue wire on the waste disposer.
- C. Use a cable clamp strain relief connector where the power cord enters the disposer.

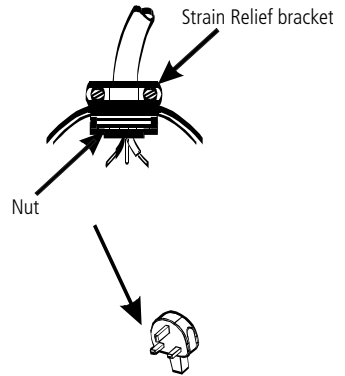

NOTE:

When viewing face of electrical plug with the earth pin at top, the left blade is connected to the identified wire.

TO WIRE YOUR DISPOSER DIRECTLY INTO THE MAINS GROUNDING INSTRUCTIONS

This appliance must be connected to a grounded, metal, permanent wiring system, or an equipment grounding conductor must be run with the circuit conductors and connected to the equipment grounding terminal or lead on the appliance.

IF YOU USE A BX CABLE:

1. These products are designed for household use.
2. Connect a line wire to blue lead of disposer with a wire nut. Connect the neutral wire to the brown lead of disposer with a wire nut. Connect the bare ground wire to the ground screw. The ground wire should be clamped and held by a strain relief bracket.
3. Do not use a rigid conduit for the wiring connection.
4. A dedicated acceptable motor switch, with the off position marked, shall be provided for this disposer at the time of installation (not included). The switch shall be mounted in sight of the disposer or the sink opening for the disposer.
5. If a BX cable is not used, provide a separate ground wire to the nearest reliable ground, using the screw in the end bell for the ground wire.

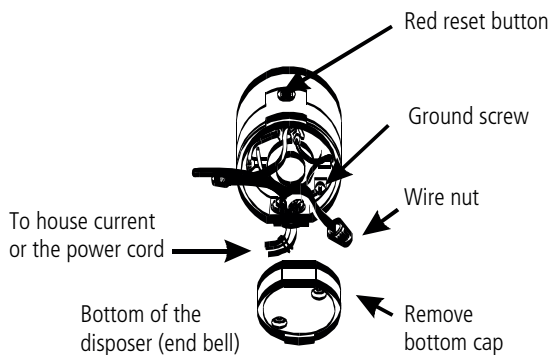

TYPICAL ELECTRICAL CONNECTION

You can install this waste disposal unit with a wall mounted control switch (not supplied).

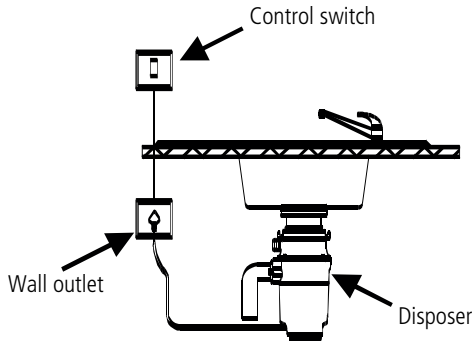

INSTALLATION INSTRUCTIONS

Before you begin read these instructions completely and carefully.

IMPORTANT

Keep these instructions.

IMPORTANT

Observe all governing codes and ordinances.

NOTE TO INSTALLER

Be sure to leave these instructions with the consumer.

NOTE TO CONSUMER

Keep these instructions for future reference.

SKILL LEVEL

The installation of this appliance requires basic mechanical skills.

COMPLETION TIME

1 hour.

NOTE

The correct installation is the responsibility of the installer.

PREPARATION

1. Disconnect electrical power supply to the disposer.
2. Remove the old disposer or sink flange assembly.
3. Inspect drain line. If it is heavily coated with hardened grease and accumulations, clean out before you proceed with the installation.
4. Remove old sealing materials and gasketing from the sink opening, both top and bottom.

NOTE

The top and bottom of the sink surfaces must be free of any materials to prevent leaks.

WHAT YOU WILL NEED



Phillips and flat blade screwdrivers



Channel lock pliers, slip joint



Nut driver



Hammer

- › Steel punch or wooden dowel
- › Petroleum jelly or liquid soap
- › Hose clamp
- › Dishwasher drain connector
- › Adjustable pipe wrench
- › Plumbers putty (for ceramic sinks)
- › Stepped rubber drain adapter
- › Wire nuts
- › Cable connector
- › Flexible drain pipe
- › Power cord kit

COMPONENTS AND INSTALLATION

NOTE:

Pay close attention to the order of the sink flange parts, as they have been correctly assembled by the factory.

- A. Disassemble the sink flange assembly from the disposer by turning the mount ring to the left (clockwise) and removing it.
- B. Raise the mount ring toward the top of the sink flange. Remove the cushion mount and the mount ring. You may want to practice installing the cushion mount at this point before you are under the sink.
- C. Unscrew the support ring from the sink flange and remove the fiber gasket. You are now left with the sink flange and the rubber gasket.
- D. The rubber gasket is used instead of plumbers putty with stainless steel sinks. Some ceramic sinks will require putty or silicone.
- E. If no putty is used, insert the sink flange through the rubber gasket into the sink opening. Do not turn the flange once it is seated.
- F. If you use putty instead of the gasket, form a ring around the underside of the sink flange. Insert the flange into the sink opening, press down hard to squeeze out excess putty. From under the sink, trim off excess putty flush with the bottom edge of the sink opening.

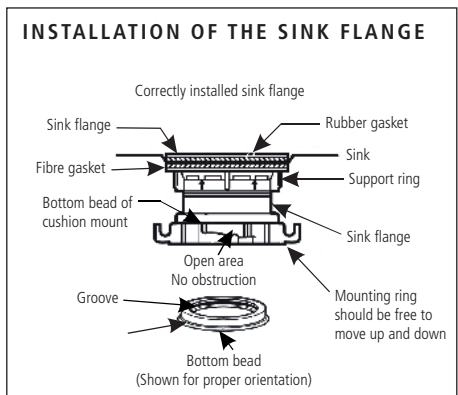
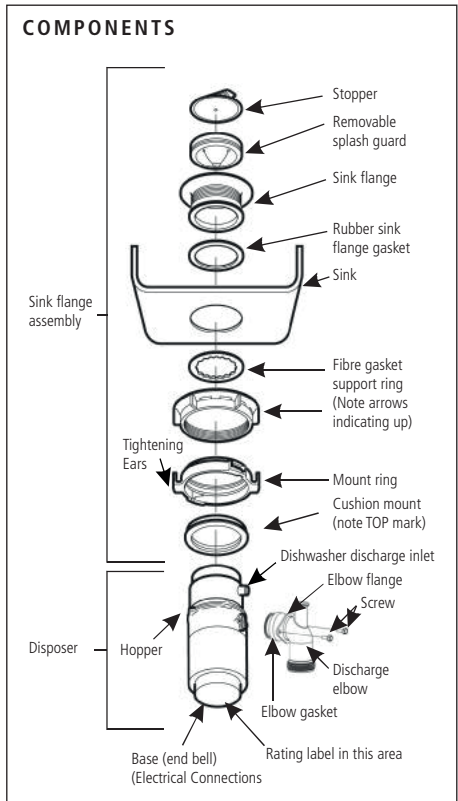

G. From underneath the sink, slip the fiber gasket onto the exposed sink flange. With arrows pointing up, screw the support ring onto the sink flange and hand tighten until the sink flange will not move. (NOTE: If your sink is more than 15mm thick you will need to flip the supporting ring so the arrows are pointing down. This will provide a greater distance on the sink flange allowing it to be used on sinks up to approximately 22mm thick). At this point you may want to insert the stopper into the sink and fill with water to check the sink flange seal and ensure there are no leaks.

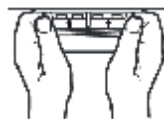

Hand tighten sink flange

H. Place the mount ring over the sink flange and hold in place while installing the cushion mount (large side down). Make sure the groove on the inside of the cushion mount fits over the lip on the sink flange, similar to putting the lid on a plastic container. Run your fingers around the entire cushion mount with slight pressure. Do not press too hard. When the cushion mount is properly seated, the mount ring can be pulled downward over the cushion mount and will be free to turn.



Cushion mount detail

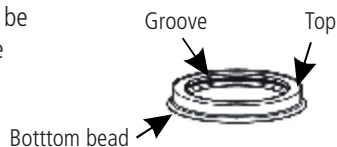

DISHWASHER CONNECTION (IF REQUIRED)

If you are connecting a dishwasher to your waste disposal unit, please complete the following steps. If you are not connecting a dishwasher proceed to connecting the discharge elbow.

1. Knock out the plug:

Using a blunt instrument (for example a steel punch or wooden dowel) knock out the entire plug. Do not use a screwdriver or sharp tool. When the knocked out plug falls into the disposer, you may remove it or simply grind it up when you first use the appliance. This will not damage the disposal unit in any way, but may take some time to grind over several uses.

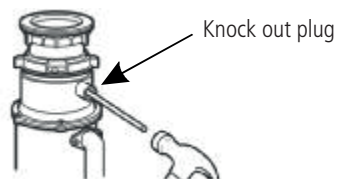

2. Connect the hose:

Connect the dishwasher hose using a hose clamp. If the hose size is different you will need a stepped rubber adapter.

CONNECTING THE DISCHARGE ELBOW

Discharge elbow must be installed by a professional. Some installations (see page 9 for examples) may require the use of a flexible drain pipe.

NOTE

If the dishwasher connection is made without removing the plug, the dishwasher may overflow.

3. Connect the discharge elbow to the disposer.

4. Make sure all plumbing connections are tight.

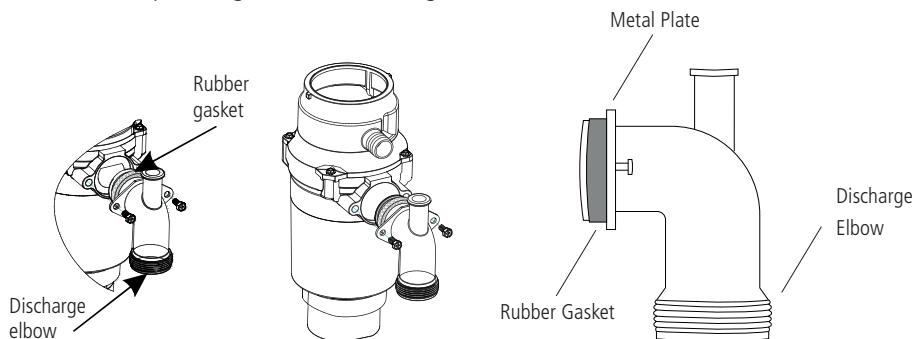

CONNECTING THE DISPOSER TO THE SINK FLANGE

1. Attach to the sink flange.

Line up the disposer under the sink flange. Guide the hopper projections into the mount ring slots. Turn the mount ring about $1\frac{4}{8}$ " to the right so that the disposer is temporarily supported.

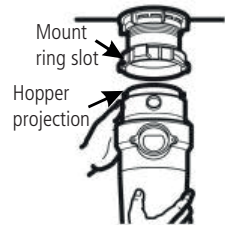

2. Line up with the outlet pipe.

Turn the mount ring and the disposer until the disposer discharge elbow lines up with the outlet pipe. See next page.

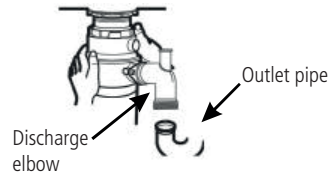

3. Lock the mount ring.

Turn the mount ring to the right until it locks up tight. Hopper projections must be to the extreme left of the mounting slots. If the mount ring is hard to turn, you may add a small amount of petroleum jelly or liquid soap to the hopper projection. Run water and check for leaks.



4. Check for leaks.

Check the unit for leaks 24 hours after installation and first operation.

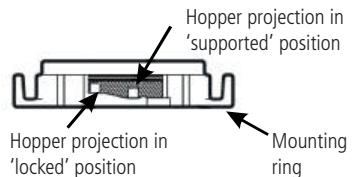

IMPORTANT:

DO NOT put your head or body under the disposer during the installation as it could fall.

DIMENSIONS

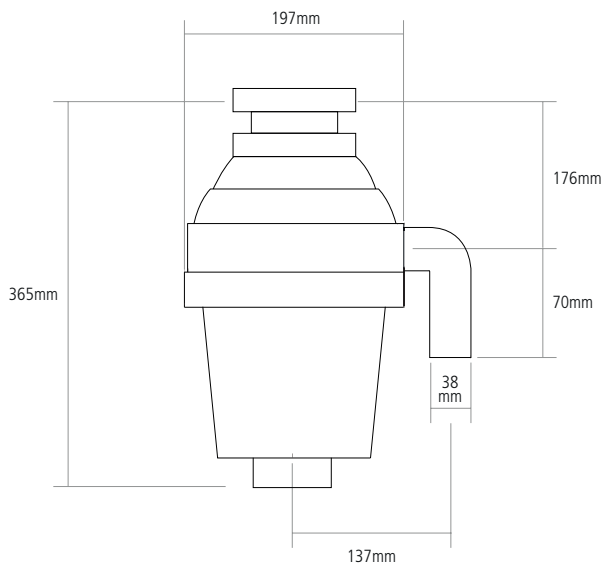

SOME TYPICAL INSTALLATIONS

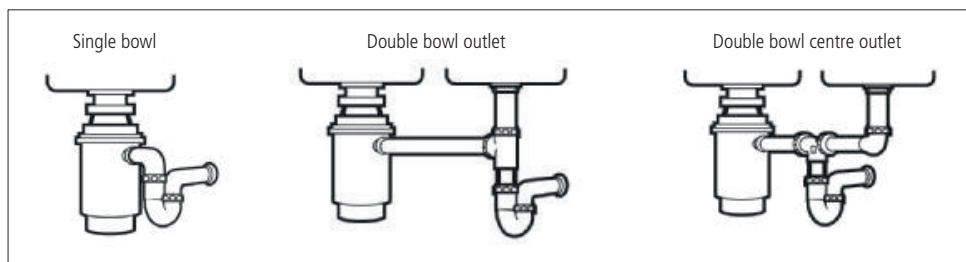

NOTE

1. It is essential for the correct operation of the waste disposer that this dimension (a) shown on the right is 230mm - 300mm depending on the models listed above, this will avoid standing water in the motor housing.
2. Flexible drain pipe may be necessary for this application.

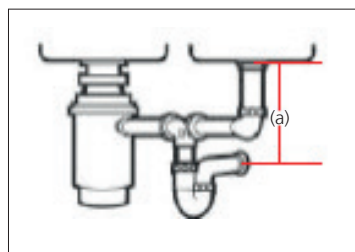

OPERATING INSTRUCTIONS

This disposer uses anti-jam swivel impellers that make a clicking sound as they swing into place. This indicates normal operation, and is not a fault.

1. Remove the sink stopper and turn on a medium flow of cold water.
2. Turn on the waste disposer.
3. Slowly insert food waste into disposer and position stopper to minimize possible ejection of material while grinding.
4. After grinding is complete, turn off the waste disposer and run the cold water for at least a further 15 seconds to flush the drain line.

HELPFUL HINTS

DO...

- › Be sure the disposer is empty before using the dishwasher so it can drain properly.
- › You may want to leave the stopper in the drain when not in use to prevent utensils and foreign objects from falling into the disposer.
- › TO SPEED UP FOOD WASTE DISPOSAL... Cut or break up large bones, melon rinds, grapefruit skins and corn cobs. Items such as large bones, fibrous husks like lima bean pods and corn husks require considerable cutting time. For this reason, you may prefer to place them in the recycling.
- › Grind peelings from citrus fruits to freshen up drain smells.
- › Use a waste disposer cleaner or deodorizer as necessary to relieve objectional odours caused by any grease build up. Also remove and clean the splash guard regularly.
- › Let the disposer run for 15 seconds after shredding stops, then once turned off allow water to rinse through for another 15 seconds, this will ensure all the waste is thoroughly flushed through the trap and drain.

DON'T...

- › Don't be alarmed if the disposer slows down when grinding, the appliance is actually increasing torque (grinding power) and is operating under normal conditions.
- › Don't pour grease, oil or fat into your waste disposer or any drain. It can build up in pipes and cause drain blockages. Put grease in a jar (when cooled) and dispose of in your bin.
- › Don't use hot water when grinding food waste, it is ok to drain hot water into the disposer when it is not in operation.
- › Don't put tin cans, bottles, bottle caps, glass, china, leather, cloth, crockery, rubber, string, feathers etc into your disposer. It is designed for food waste only.
- › Don't fill the disposer with food all at once. Turn on the cold water flow and gradually feed in the food waste.
- › To avoid possible drain blockages don't grind extremely fibrous food waste like whole corn husks, artichokes, celery etc.
- › Don't turn off your waste disposer until grinding has completed and only the sound of the motor and water can be heard.

CARE AND MAINTENANCE

THE MOTOR IS PERMANENTLY LUBRICATED FOR LIFE. DO NOT ATTEMPT TO LUBRICATE YOUR DISPOSER.

The disposer is self cleaning and scours itself with each use.

- › NEVER put bleach or chemical cleaners into the disposer, as they cause serious corrosion of metal parts.
- › Your disposer is equipped with a removable splash guard for ease of cleaning or replacement. Remove the splash guard by pulling it out from the top. To replace, insert into the sink flange and push down until it is properly seated.
- › If an odour develops, run orange or lemon rinds through the disposer. A dozen ice cubes sprinkled with a little household scouring powder will also work.

TROUBLESHOOTING TIPS

BEFORE CALLING CAPLE SERVICE

Review the below chart before contacting Caple Service as you may find a simple solution, saving you both time and money.

SAFETY NOTE

Before investigating any possible issues you **MUST** disconnect the power supply.

WARNING

Before resetting, disconnect the power supply, please see SAFETY NOTE above. The overload control prevents the motor from operating should overloading occur. This feature protects your house wiring and your disposer. When overloaded, the motor will stop automatically.

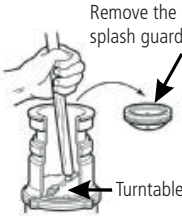
PROBLEM	POSSIBLE CAUSES	WHAT TO DO
<p>Loud noises (other than those during grinding of bones and fruit pits)</p>	<p>Silverware , bottle cap or other foreign object has fallen into the disposer.</p>	<p>Remove the splash guard and remove the object with long-handled tongs, then replace the splash guard</p>
<p>The disposer does not start</p>	<p>Reset button has been tripped.</p> 	<p>With the splash guard removed, check to see if the turntable will move freely using a wooden spoon. If the turntable moves freely, replace the splash guard and check the reset button to see if it has been tripped. The reset button is red and located opposite the discharge elbow, near the bottom of the disposer. Push the button in until it clicks and remains depressed. If the reset button has not been tripped, check for a shorted or broken wire connecting the disposer. Check the electrical power switch, fuse box or circuit breaker. If the wiring and electrical components are intact, the unit may have internal problems that require service or replacement.</p>
	<p>Turntable cannot rotate.</p> 	<p>If the turntable does not turn freely, check for an object lodged between the turntable and the grind ring. Dislodge the object by moving the turntable with a wooden spoon handle. Then remove the object. If no foreign object is present, there may be internal problems. Contact Caple Service.</p>
<p>The disposer leaks</p>	<p>If the leak is at the top, it may be caused by:</p> <ol style="list-style-type: none"> 1. Improper seating of the sink flange (gasket choice, putty or tightening). 2. Support ring is not tightened properly 3. Defective cushion mount. <p>If the leak is at the discharge elbow , the leak may be caused by improper tightening of the elbow flange screws.</p>	<p>Check the installation and correct as required.</p>

NOTES



Caple Service
Fourth Way
Avonmouth
Bristol
BS11 8DW

T: 0117 938 1900
E: service@caple.co.uk
www.caple.co.uk