



WMI3007

Caple Integrated Washing Machine 1400rpm



Technical Manual



WMI3007

Caple Integrated Washing Machine 1400rpm

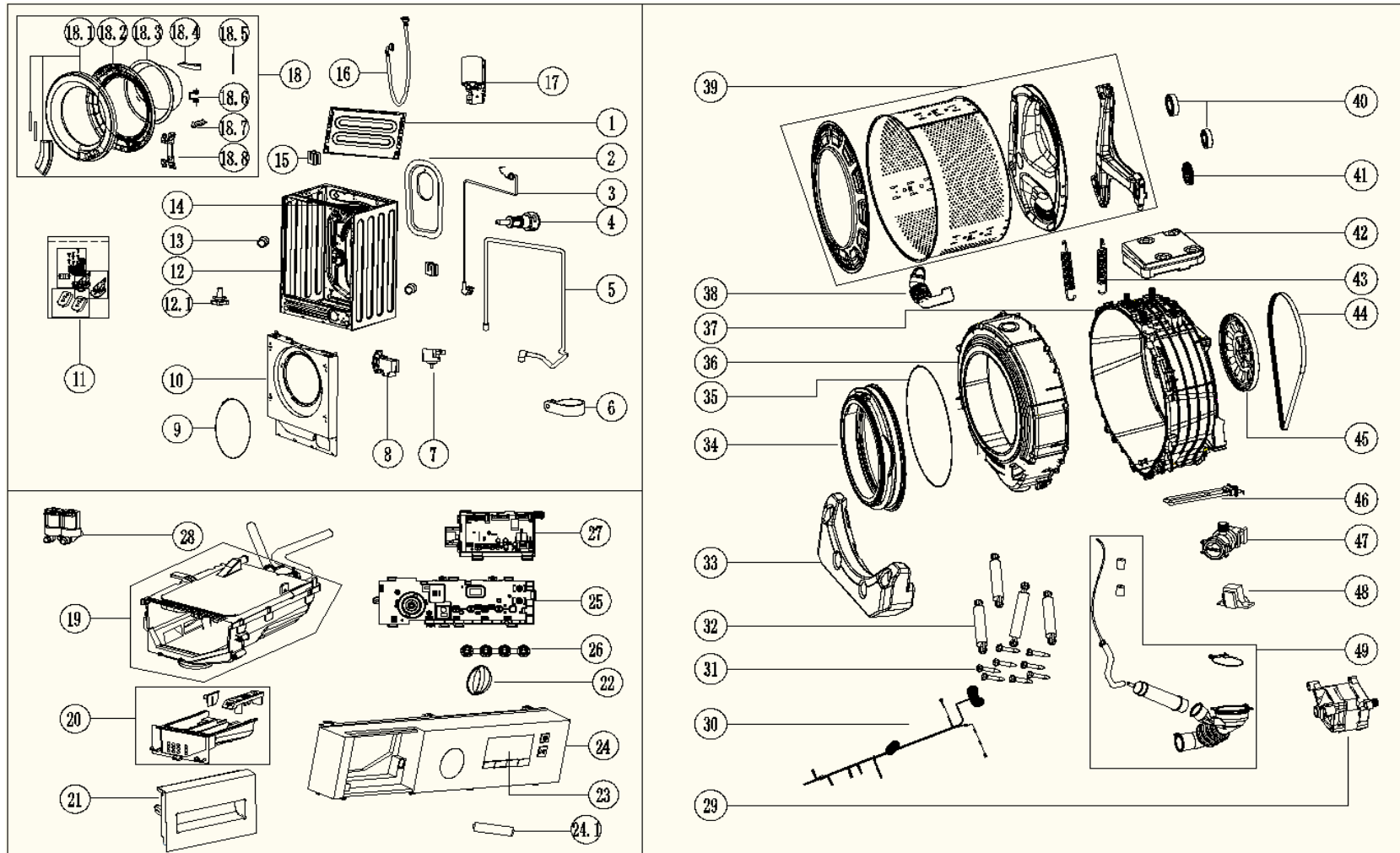



WMI3007

Caple Integrated Washing Machine 1400rpm

Item	Part Number	Description	Quantity
1	12238100001250	Sheet metal Top Cover	1
2	12238100002053	Rear Cover	1
3	17438100000550	European Standard Power Cord	1
4	12938100000062	Shipping Screw Assembly	4
5	12600501000908	Up Drain Hose Assembly	1
6	12138100003094	Drain Hose Catch	1
7	17438100001348	Water Level Sensor	1
8	17438100000456	Door Lock	1
9	12938100000047	Door Gasket Spring Clip Spring	1
10	12238100002901	Front Panel Assembly	1
11	16338100002221	Accessory Assembly	1
12	12238100009383	Cabinet Assembly	1
12.1	12638100003322	Adjustable Foot Assembly	4
13	12138100027886	Front Panel Pin Assembly	2
14	12238100003261	Top Bracket	1
15	12138100003060	Spring Support	2
16	12038100A00301	Water Inlet Hose Assembly	1
17	17438100008045	Electric Filter Assembly	1
18	12138100019606	Door Subassembly	1
18.1	12138100010082	Outer Frame Assembly	1
18.2	12138100006744	Inner Ring	1
18.3	12538100000006	Door Glass	1
18.4	12338100000216	Door Latch	1
18.5	11302804000011	Pin	1
18.6	12900101000243	Torsion Spring	1
18.7	12138100001922	Door Plunger Stand	1
18.8	12338100000185	Hinge Assembly	1
19	12138100026224	Dispenser Subassembly	1
20	12138100008249	Drawer Assembly	1
21	12138100A29910	Drawer Handle Assembly	1
22	12100403000884	Cycle Select Knob	1
23	12138100A29909	LED Decorate Plate And Printing	1
24	12138100A56086	Control Panel Subassembly	1
24.1	11201807002323	Digital display screen	1
25	17138100029273	Display Panel	1
26	12638100000559	Silicone Button	1
27	17138100028990	PCB	1
28	17438100000413	Water Inlet Valve	1
29	11002015018757	Brushless DC Motor	1



WMI3007

Caple Integrated Washing Machine 1400rpm

Item	Part Number	Description	Quantity
30	17438100006805	Internal Wire Assembly	1
31	12138100002987	Damper Pin	8
32	12938100000466	Damper	4
33	12738100000008	Lower Counterweight	1
34	12638100000441	Door Gasket	1
35	12938100000016	Door Gasket Clamp	1
36	121381000029447	Front Tub	1
37	12138100019040	Rear Tub Assembly	1
38	12638100000278	Tub Water Inlet Hose Assembly	1
39	12238100000523	Basket Assembly	1
40	12938100000128	Bearing	1
40	12938100000129	Bearing	1
41	12638100004022	Oil Seal	1
42	12338100003642	Upper Counterweight	1
43	12900104000017	Suspension Spring	2
44	12638100000421	Belt	1
45	12338100000148	Belt Wheel	1
46	17438100000434	Heater	1
47	11001011000245	Permanent Magnet Synchronous Pump	1
48	17400306001863	Choke	1
49	12638100000488	Tub Drain Hose Assembly	1



WMI3007 Wiring Diagram

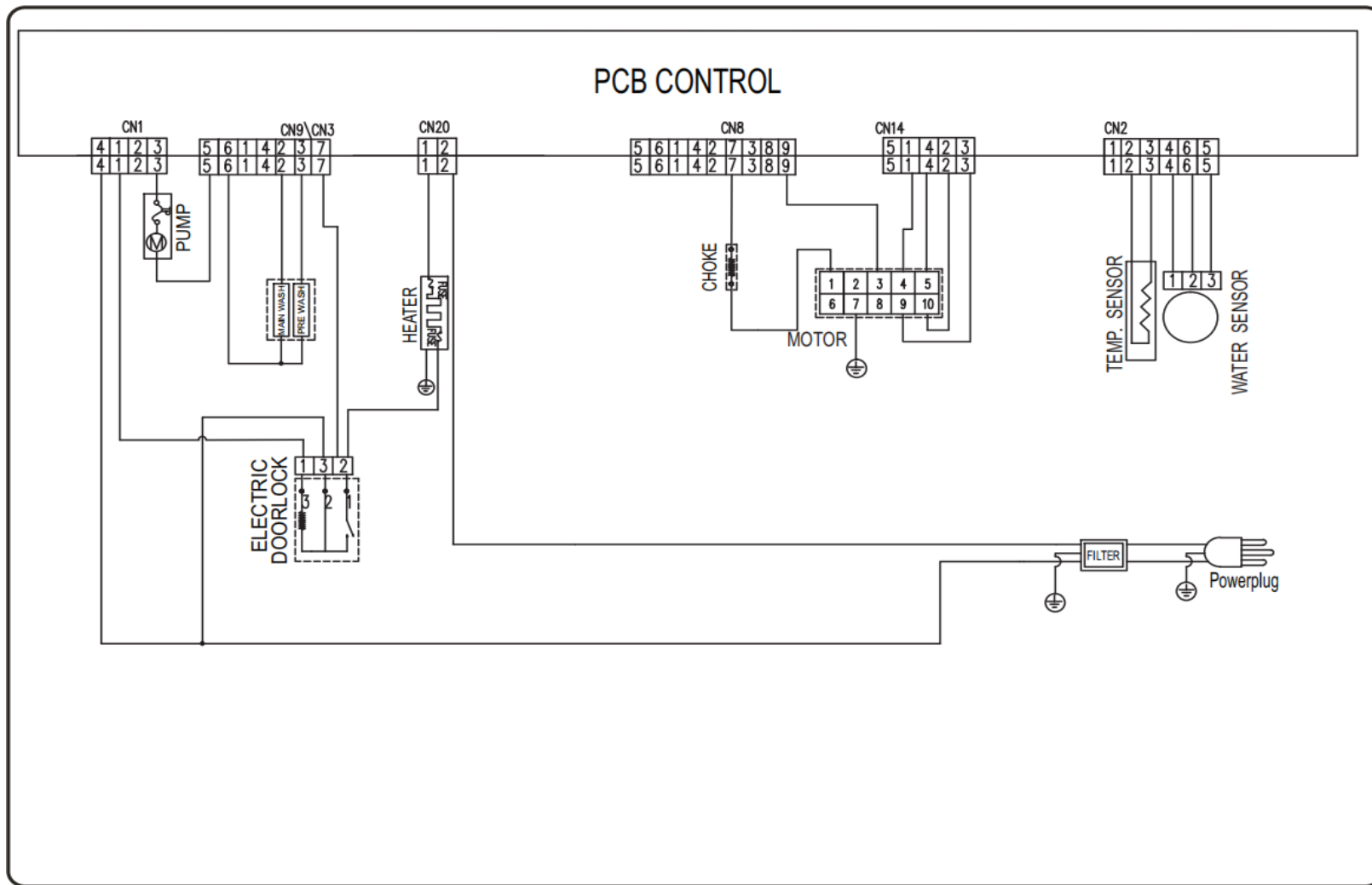



WMI3007
Service Manual



Contents

1 PRECAUTION.....	3
1.1 Safety Precautions	
1.2 Servicing Precaution	
1.3 Cautions For Safety	
2 FACTORY PATTEN DETECTION	7
3 UNPACKING WAYS OF MAIN PARTS.....	11
4 MALFUNCTIONS CODES AND EXPLANATIONS	19
5 TROUBLESHOOTING	24
5.1 Maintenance non-heating malfunction	
5.2 Door non-locked & its maintenance	
5.3 Door non-locked & its maintenance	
5.4 Heating beyond the setting temperature its maintenance	
5.5 Maintenance of non-drain or drain exceed the setting time	
5.6 Water inlet overflow malfunction maintenance	
5.7 Drum non-rotating malfunction maintenance	
5.8 Maintenance water inlet and water outlet at the same time	
6 CHECK POINT OF CIRCUIT	34
7 SERVICE TOOLS.....	35

Note:

**Before service the unit, please read this manual first.
Contact with your service center if meet problem**

When performing troubleshooting and part replacement during servicing, note the following safety precautions:

1.1 Safety Precautions

1.1.1 Use Genuine Parts

The components of the washing machine have safety features such as non-combustibility and voltage with standing. Therefore, always use the same part as suggested by the maker.

In particular be sure

to use only designated parts in case of major safety parts identified by the marker.

1.1.2 Grounding

Connect the grounding wire to the shell plate, and bury it under at least 25cm of earth: alternatively, connect the ground wire to the appropriate pin on a properly grounded power receptacle. Never connect the wire to a telephone line, lightning rod, or gas pipe.

1.2 Servicing Precautions

1.2.1 Observe Warnings

Be sure to follow special warning and precautions that are described on part labels and in the owner's manual.

1.2.2 Parts Assembly and Wiring

Be sure to use insulation material (such as tube and tape). And be sure to restore all parts and wires to their original position. Take special care to avoid contact with sharp edges.

1.2.3 Perform Safety Checks after Servicing

After servicing, check to see that the screws, parts, and wiring are restored to their original positions, and check the insulation between the external metals and the socket plug. In addition, place the washing machine in a level position (less than 1 degree) to prevent vibration and noise during operations.

1.2.4 Insulation Checks



Pull out the plug from the power receptacle, pour water into the spin tub, and then set the timer.

Check to see that the resistance insulation between the terminals of the plug and the externally exposed metal is greater than 1M.



Note :When it is impossible to insulation check with a 500V insulation resistance tester, use other testers for inspection.



1.3 CAUTIONS FOR SAFETY









- Please observe the following notes for safety.
- The symbols indicate as follows.





Symbol	Meaning
 WARNING	Indicates possibility of death or serious injury of a repair technician and a person nearby through the misconducted work , or of a user by a defect of the product after the work performed by the technician.
 CAUTION	Indicates possibility of injury or physical damages* of a repair technician and a person nearby through the misconducted work , or of a user by a defect of the product after the work performed by the technician.

* Means secondary damages of property, furniture , domestic animal and pet.

Symbol	Meaning
 ELECTRIC SHOCK	Indicates a caution (including a warning). Specific instruction is followed by a graphic or characters in or near. Symbol left warns an electric shock.
 DO NOT DISASSEMBLE	Indicates prohibition (act must not be conducted). Specific instruction is followed by a graphic or characters in or near. DO NOT Symbol left warns not to disassemble.
 UNPLUG	Indicates forcing (act must be conducted). Specific instruction is followed by a graphic or characters in or near . Symbol left warns to unplug the power cord.

Symbol	Meaning
 OUT OF CHILD	Advise the customer to keep children out of the work place. Children may be injured with a tool or a disassembled part.
 UNPLUG POWER	Unplug power cord for the work such as disassembling which is not unnecessary to power on . Do not hold the plug by a wet hand. Failing to unplug may cause an electric shock.
 USE REPAIR PARTS	Use the specified repair parts when repairing the product. Otherwise , amalfunction or a defect may occur. Also , a short circuit , ignition or other danger to the customer may occur.

WARNING	
 CHECK INSULATION RESISTANCE	<p>After repair, measure insulation resistance between the charging part(power cord plug) and the non-charging metallic part (ground) with an insulation resistance meter (500V).The resistance shall be 10M or more.</p> <p>Failing to check the insulation resistance may cause a short circuit, electric shock or other diseases to the customer.</p>
 DO NOT MODIF	<p>Do not modify the product.</p> <p>An electric shock or ignition may occur.</p>
 DO NOT MODIFY	<p>Only a repair technician can disassemble and repair.</p> <p>An electric shock, ignition or malfunction may cause injury.</p>
 USE EXCLUSIVE SOCKET	<p>Use an exclusive 110 VAC/15 A socket for the washing machine.</p> <p>Use an exclusive 220VAC/17A socket for the washing machine.</p> <p>Otherwise , an electric shock or ignition may cause. Sharing the same socket with other instrument causes heating of a branch socket and result in a fire.</p>
 CONNECT GROUNDING WIRE	<p>Connect the grounding wire.</p> <p>Failing to do so may cause an electric shock when a short circuit occurs.</p> <p>Consult an electric work shop or a sales shop.</p>
 DO NOT USE WET PLACE	<p>Do not install in a bath room or a place exposed to wind or rain.</p> <p>An electric shock or a short circuit may cause a fire.</p>
 DO NOT SPLASH WATER	<p>Do not pour or immerse electrical parts into water or liquid solution.</p> <p>An electric shock or ignition may occur.</p>
 REMOVE DUST	<p>Wipe off dust adhered to the plug of power cord.</p> <p>Dust may cause a fire.</p>
 AVOID INFLAMMABLE	<p>Do not put inflammable into the washing tub.</p> <p>Do not put cloths stained with kerosene, gasoline, benzene, thinner, alcohol, etc. It may cause a fire or explosion.</p>

WARNING	
 DO NOT TOUCH	Do not touch the laundry before the spin basket stops completely. The laundry entangles your hand causing an injury even if the basket rotates slowly. Pay special attention to children.
 INSTALL CAREFULLY	Ask an electric work shop to install the product. Install the product securely and safely according to the electrical equipment technical standard and the wiring standard. Incorrect work causes an electric shock and a fire.
 DO NOT PULL	Do not pull the power cord when unplugging. Hold the power plug to unplug. An electric shock or short circuit may cause a fire.
 DANGER HAND	Do not insert your hand under the washing machine during operation. There is a rotary part under the machine which may cause an injury.
 WATER LEAKAGE	Before starting washing, open the faucet and check water supply hose joint which shall not be loosened for no water leaks. The loose screw or hose joint may cause water leakage resulting in an unexpected damage.

2.1 Service mode

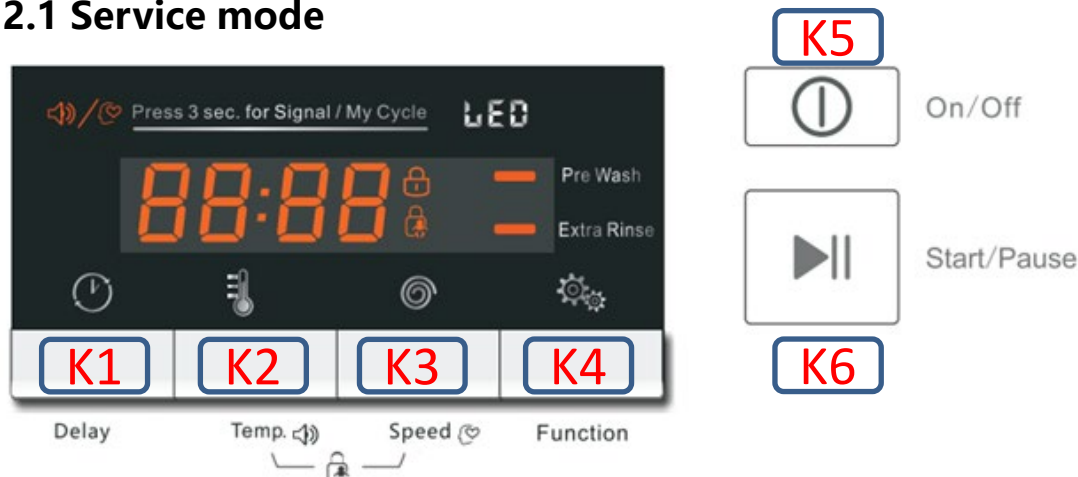

Before entering into service mode, make sure no water remains in the inner drum, if not, select drain only program to drain them out.

Turn on the machine and take turns [K2] [K4] [K2] [K4] buttons in 30s.

Press [K1] or [K2] to select test program. Press [K6] button to confirm your selection and start the selected test. If you want to go back to test selection interface, press the [K6] button to cancel previous selection.

LED Display	Check Target	Check Method	Check Item
t01	Version switchover	<ol style="list-style-type: none"> 1. Press [K6] button 2. Press [K2] to change version 3. Press [K1] button continuously for 3s to confirm your change 	LED displays "0xx" x means current version
t02	Error code checking	<ol style="list-style-type: none"> 1. Press [K6] button 2. Press [K1] to show the last code and press [K2] to show the next code 3. Press [K2] and [K3] button at the same time continuously for 3s, after hearing the beep, all the error codes records deleted, LED displays E00. 	LED displays "Err"
t03	Version information checking	<ol style="list-style-type: none"> 1. Press [K6] button Enter into service mode, LED displays "cod" . 2. Press [K6], LED displays project number. 3. Press [K1] button, LED displays version number 	LED displays version number

2.1 Service mode

LED Display	Check Target	Check Method	Check Item
t04	UI Checking	Press [K6] button	The whole LED display flashes
t05	Drain-pump checking	Press [K6] button to drain out all the remaining water. If all water drained out, LED displays "EP" , and 6 minutes later ,if there is still water remains in it, LED displays "FP"	LED displays "PPT"
t06	Pressure switch checking	1. Press [K6] button to activate inlet valve. LED displays level frequency once water lever get the main wash level.	LED displays LL
t07	Water temperature sensor and heater checking	Press [K6] button to activate the main inlet valve and get the water lever to heating level then turn on the heater and 5 mins later turned off automatically	LED displays the current temperature
t08	Inlet valve checking	<ol style="list-style-type: none"> 1. Press [K6] button, LED displays "uu" and switch on the main wash inlet valve for 10 min. 2. Press [K1] button, LED displays "u1" and switch on prewash valve for 5s. 3. Press [K1] button, LED displays "u2" and switch on the main wash inlet valve for 5s. 4. Press [K1] button to switch on main wash and prewash valve and get the water lever to setting level, then drain out the water. 	LED displays "UU"

2.1 Service mode

LED Display	Check Target	Check Method	Check Item
t09	Rotating checking	Press [K6] button, inner drum rotates in 45r/m clockwise for 15s and stop for 10s then rotates counterclockwise for 15s, over and over again.	LED displays "tUB"
t10	Spin speed checking	Press [K6] button , the number on the display goes up in the same pace with the real speed and when it reach 400rpm, you need to press [K1] button to get the machine to reach its target speed	LED displays "spn"

2.2 Self-check

Push the buttons of function and pre-washing without loosening, in the meantime screw the program knob to the position of cotton and keep 3s, then the program will be in the state of self test. When the buzzer toots, all the indicating lights glitter 3 times (pushing 0.5s, the 0.5s light is on and off), then the lights are on all the time. When the knob screw to the following position in this time and push the button of start/off, the test is effective.

1. Delay washing test (cotton normal water):the maximum inlet water time is 10s.
2. Main washing test(cotton 40°C): the maximum inlet water time is 10s.
3. Washing test(cotton 60°C): the maximum inlet water time is 10s.
- 4.Heating test(cotton 90°C): estimate whether the water level is 1, if not, adding water to 1, then begin to heat in the maximum of 10 minutes.
- 5.Tub leaking test(speedy washing 30°C): estimate whether the water level is 1, if not, adding water to 1, according to cycle of clockwise 10s-stop 2s-anticlockwise 10s to test in the rotate speed of 250rpm (fault alarm E6/E7).
6. Drain test (single drain): if the water level is below 1, it is plus 40s (malfunction alarm E3).
7. Dehydration (single dehydration): judge whether the water level is below 1, if not, drain water until it is below the 1 plus 20s, then dehydrate in the maximum of speed (unbalanced test is needless), the maximum time is 10 minutes(fault alarm E5).

NOTE:

- 1) The tests foregoing are reversible.
- 2) It is need to close the door lock before each test , or else the door clock is malfunction alarm E1.
- 3) The knob can be screwed to every position, the corresponding test is valid once pushing the start/pause button.
- 4) If the knob is not in the position of that test, there is not responsive.
Exit need to close the power.

2.3 Marketing-show (no-water testing)

Target: in order to display the washer' s operation in the supermarket, set up display mode.

Operation program: push the function + pre-washing button and screw the knob to 40°C, keeping 3 minutes, when the buzzer toot, it enter the sales display mode. In the mode, the washer without and the heater without power, run the two minutes standard cotton washing + washing program and three minutes dehydration program after pushing the start/pause button, then stop, if you push the start/pause button again, the operation repeat.

Exit need to cut off the power.

3. UNPACKING WAYS OF MAIN PARTS

1. Undo the back cover
2. Undo top cover
3. Undo the control panel
4. Undo the lower panel
5. Undo the door lock
6. Undo the front plate
7. Undo the facade counterweight
8. Undo the gasket
9. Undo the PCB panel
10. Undo the detergent box
11. Undo the inlet valve
12. Undo the pressure
13. Undo the pulley
14. Undo the absorber pin
15. Undo the filter
16. Undo the drain pump
17. Undo the heater
18. Undo the NTC
19. Undo the door glass
20. Undo the panel support
21. Undo the drum tub assembly
22. Undo the absorber
23. Undo the motor

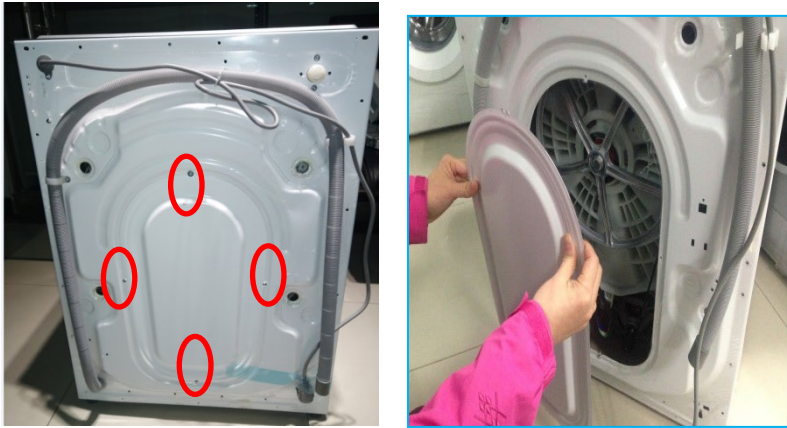
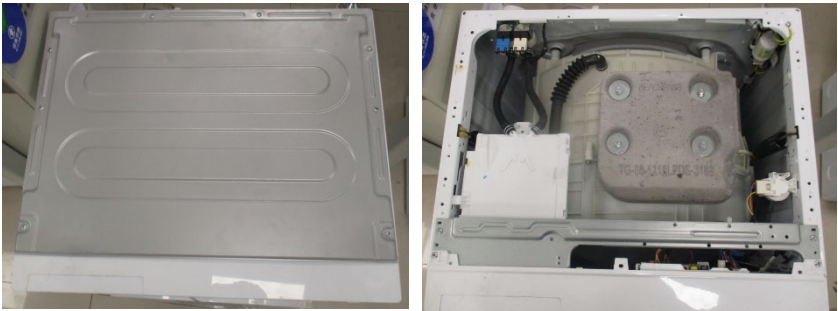
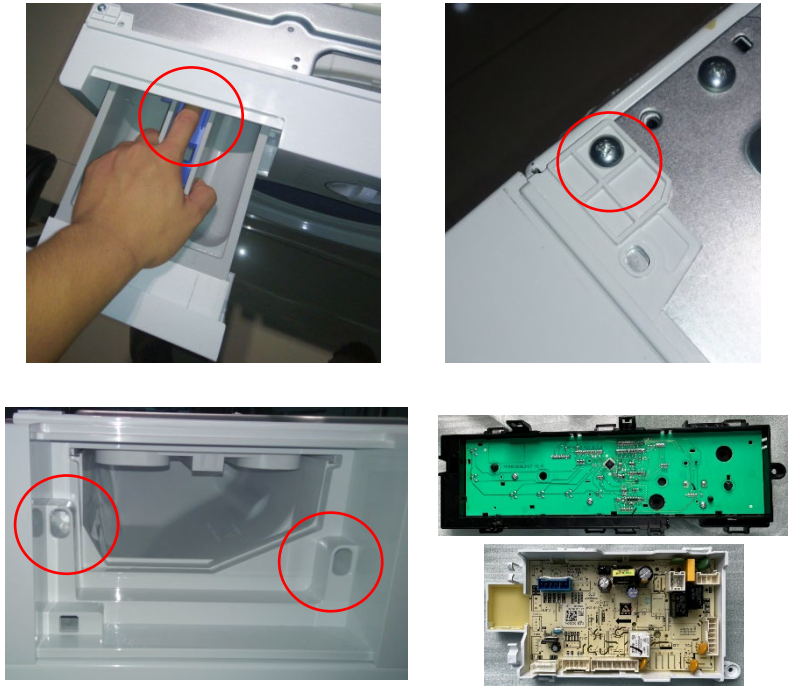
Operation	Picture
<p>1. Undo the back cover Undo four screws fit between back plate and cabinet, and then pull out.</p>	
<p>2. Undo the top cover I. Undo 6 screws on the Cabinet. II. take it down.</p>	
<p>3. Undo the control panel I. Departing the top cover II. Draw out the detergent drawer. III. Loosen two screws fit on the control panel. IV. Loosen two screws fit on the control panel. V. Take out the control Panel inclined from the panel.</p>	

4. Undo the door assembly

Undo the door

- I. Open the door of washing machine.
- II. Take the outer gasket
- III. Remove two screws on the door and take down the door .

Undo the door gasket

- I. Remove the outer gasket clamp between the door seal and the front plate. Loosen the inner gasket clamp between the door seal and the front of the outer tub.

Undo the door lock

- I. Remove two screws on the door lock, and take down the door lock.
- II. Take out the door lock and draw out the plug.

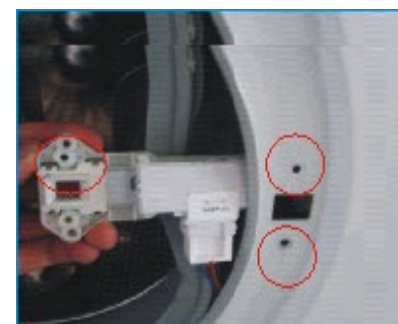
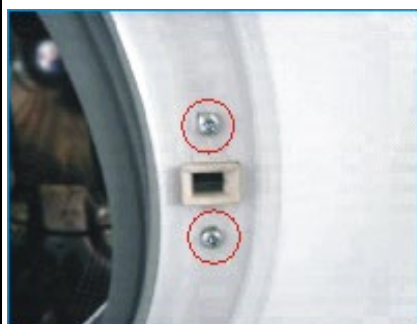
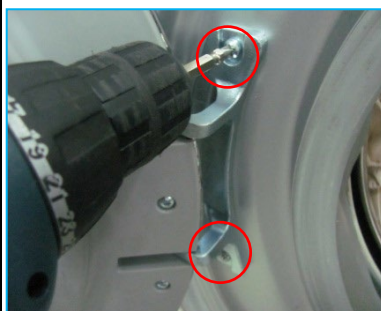

5. Undo the front plate

- I. Remove the lower cover.
- II. Undo 7 screws in front plate
- III. Put the front plate up to the clasp of the front plate away from the loading holder, and then take off the front plate.



6. Undo the facade counterweight

- I. Undo the front plate
- II. Remove 4 screws pull out the facade counterweight.



7. Undo the detergent box

I. Release the hose clamp and pull out the inlet hose.
II. Release the hose clamp and pull out the detergent box hose, and then take out the detergent box. 1.
III. Undo 2 screws between cabinet and inlet valve. Release the clamp fixing the inlet valve and the inlet hose, and then pull out the inlet hose

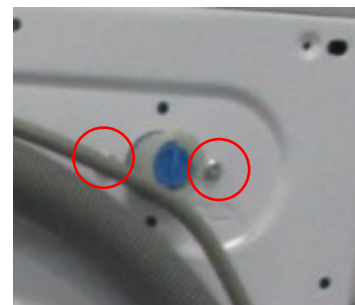

8. Undo the pressure switch

I. Undo the top cover
II. Pull out the plugs on the pressure switch.
II. Loosen the pressure switch hose clamp, and pull out the hose from the pressure switch interface.
III. Rotate the pressure switch anticlockwise by 90°, and then pull out the pressure switch.

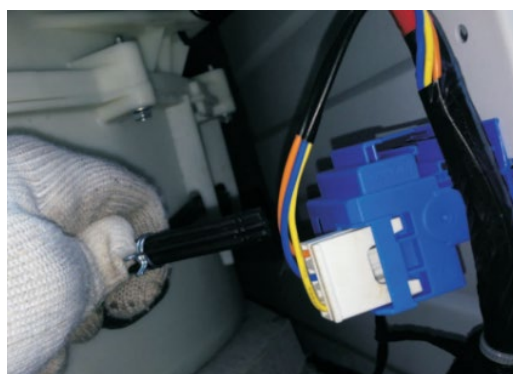

9. Undo the drain pump
 I.Pull out the terminal behind the drain pump.
 II.Nip out clamp between drain hose and the drain pump, and then pull out the drain hose.
 III.Loosen the screws fitted on the drain pump, and then pull out the drain pump.

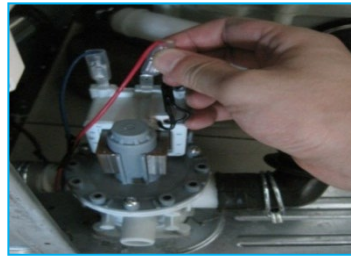

10.Undo the pulley and motor

Undo the pulley

Rotate the pulley and at the same time pull out the belt.

Undo the motor

I.Let the machine lie down on the back and then pull out the motor wire and grounding wire.
 II.Use spanner to remove the motor screw, and lift up the motor with the other hand in case of falling to the drain pump

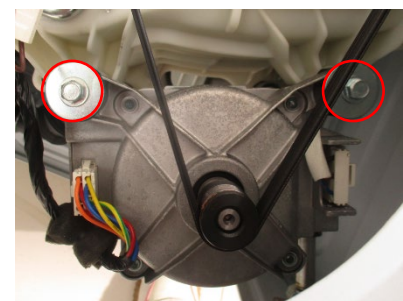
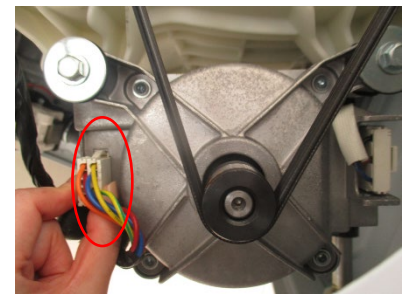

11. Undo the absorber pin from the cabinet

Use pliers to pinch the absorber pin's protuberance, and knock the absorber pin out from back lightly; in the same way, remove the other one



12. Undo the drum tub assembly

Undo the upper and façade counterweight

I. Remove 3 screws fit on the upper counterweight and then pull out it.

II. Remove 6 screws pull out the façade counterweight.

Undo the panel support

Remove two screws fixing the panel support, and then remove it.

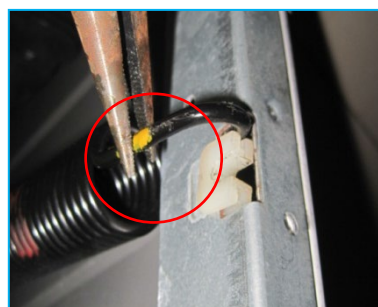

Undo the drum tub
 Remove the screws fixing the pulley, and then
 V.Remove the screws fixing the front and rear tub, and then remove the tub.
 VI.Remove the inner drum kit.

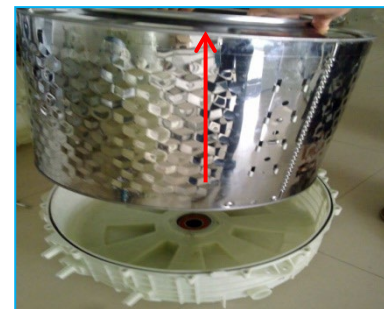

13. Undo the absorber from the drum

I.Lift out the outer tub kit.
 II.Undo the absorber pin between absorber and rear tub, remove the absorber.



14.Undo the heater and NTC

I.Pull out the heater plug.
 II.Pull out the NTC .

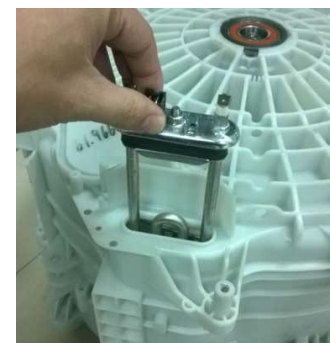

Error Code	Unit Action	Causes	Explanation
E10 In 7 minutes, the water level doesn't change with valves open	Unit will close valve and stop with Error code display	Low Water Pressure from House Supply	If the washer fills very slowly, the water pressure from the house might be too low. If the water inlet valve isn't leaking and there are no other symptoms this problem does not need to be corrected.
		Water inlet hose	Make sure that water faucet is turned on and that the screens on the hoses are not restricted.
		Water inlet valve (The voltage on the water inlet valve is normal)	If the water pressure is good, try cleaning the screens inside the water inlet valve hose connection ports. If those are clean replace the water inlet valve.
		Water level sensor or control switch (No voltage on the water inlet valve)	A water lever control switch controls how much water enters the washing machine by PCB. If the water level control switch is defective, or more commonly , if the small air pipe attached to the air bell restricted, The switch will not be able to close the electrical contacts to the washer fill valve. CHECK THE AIR PIPE CHECK THE WATER LEVERL SENSOR CHECK THE PCB and the inner wire between PCB and the sensor

Error Code	Unit Action	Causes	Explanation
E12 Overflowing.	Unit will close valve and stop with Error code display	Restart	Some time just restart the unit can solve the problem.
		Water inlet valve (The voltage on the water inlet valve is normal)	If the washer is overflowing, the water inlet valve has failed. Replace it.
		Water level sensor or control switch (No voltage on the water inlet valve)	A water lever control switch controls how much water enters the washing machine by PCB. If the water level control switch is defective, or more commonly, if the small air pipe attached to the air bell restricted, The switch will not be able to close the electrical contacts to the washer fill valve. CHECK THE AIR PIPE CHECK THE WATER LEVERL SENSOR CHECK THE PCB and the inner wire between PCB and the sensor

Error Code	Unit Action	Causes	Explanation
E20 Pump open circuit	Unit will close valve and stop with Error code display	Pump	Check the pump or the and the inner wire of the pump
E21 Washer Won 't Drain. Or drain timeout	Unit will close Pump and stop with Error code display	Drain Hose	If the washer won't drain water check the drain hose. Be sure the hose did not get kinked behind the washer. Also, remove the hose from the pump and check it for obstructions .
		Pump	If the washer won't drain water the drain pump might be defective. It's also common for a small sock or other article of clothing to get caught in the drain pump or in the drain hose. Check both for an obstruction before replacing the pump.
		PCB	Check PCB

Error Code	Unit Action	Causes	Explanation
E30 Washer Door Won't Lock	Try 6 times, not lock	Door Lock	If the door won 't latch , the door lock assembly might be defective. If the door won' t latch ,check the door to see if the door is closed before replace it.
		PCB	If the washer door won 't unlock the problem might be the main control board. This is not common. Check the inner wire between the PCB and the door lock. .
E31 Washer Door Won't unlock		Door Lock	If the door won ' unlock, the door lock assembly might be defective. If the door won' t latch ,check the door to see if the door is closed before replace it.
		PCB	If the washer door won't unlock the problem might be the main control board. This is not common. Check the inner wire between the PCB and the door lock.

Error Code	Unit Action	Causes	Explanation
E33 Water level sensor error	Unit will close valve and stop with Error code display	Water level sensor or control switch (No voltage on the water inlet valve)	E33 means the unit can't detect the Signal of Water level sensor. CHECK THE WATER LEVEL SENSOR CHECK THE PCB and the inner wire between PCB and the sensor
E34/E35 NTC error	The water temperature in the drum exceed a certain level for alarm(background)	Water Temperature Sensor Failure	Check the heater NTC
E64 Inverter PCB error	Motor Inverter and Main PCB communication fault	Inverter PCB fault	1.Check the Motor Inverter PCB board or main PCB board 2.Check the connect wire
E80 Display PCB error	Display PCB and Main PCB communication fault	Display PCB fault	1.The Connect wire is broken 2.Check the Main PCB board

Fault tree

1. Maintenance non-heating malfunction

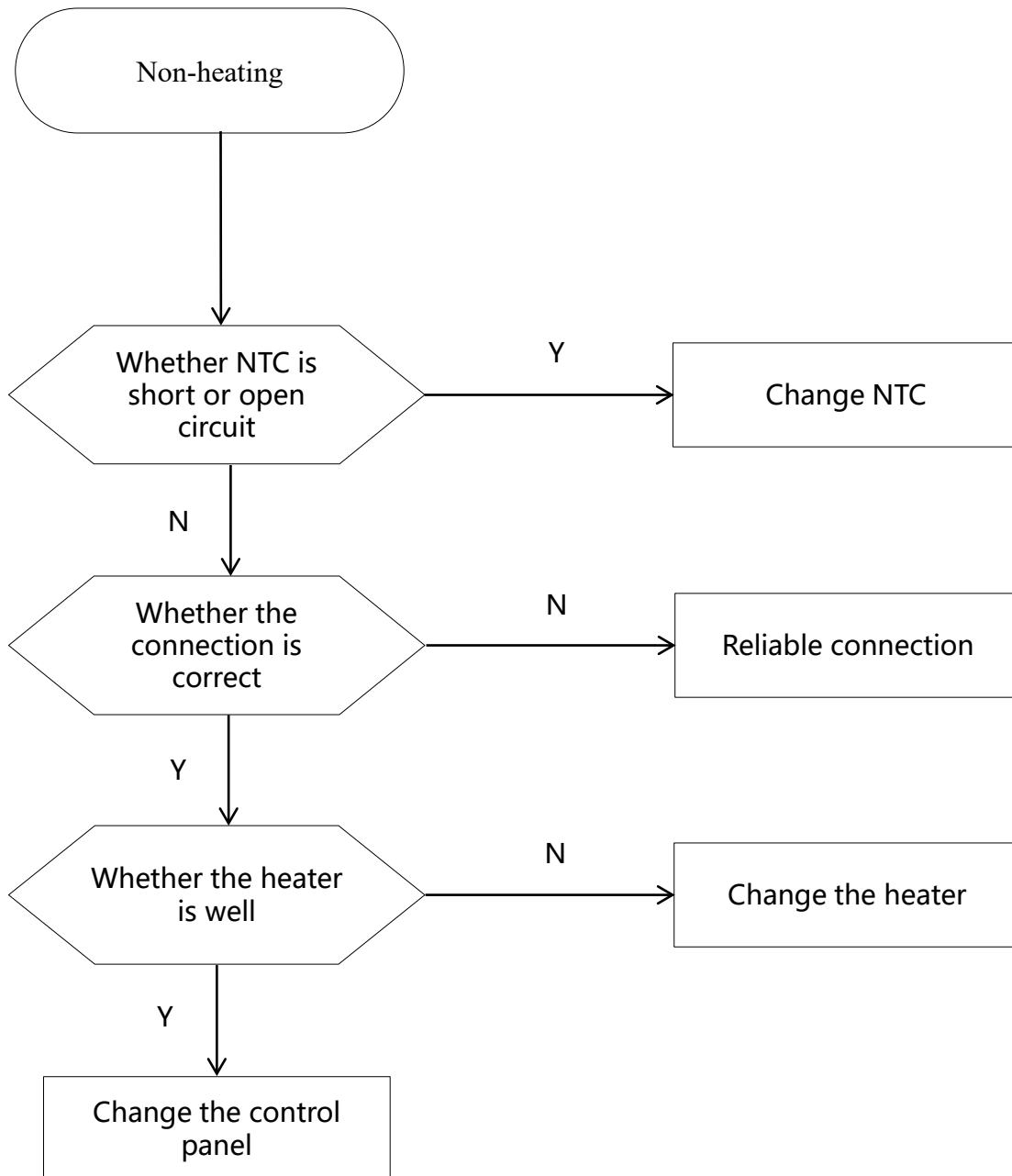

2. Door non-locked & its maintenance

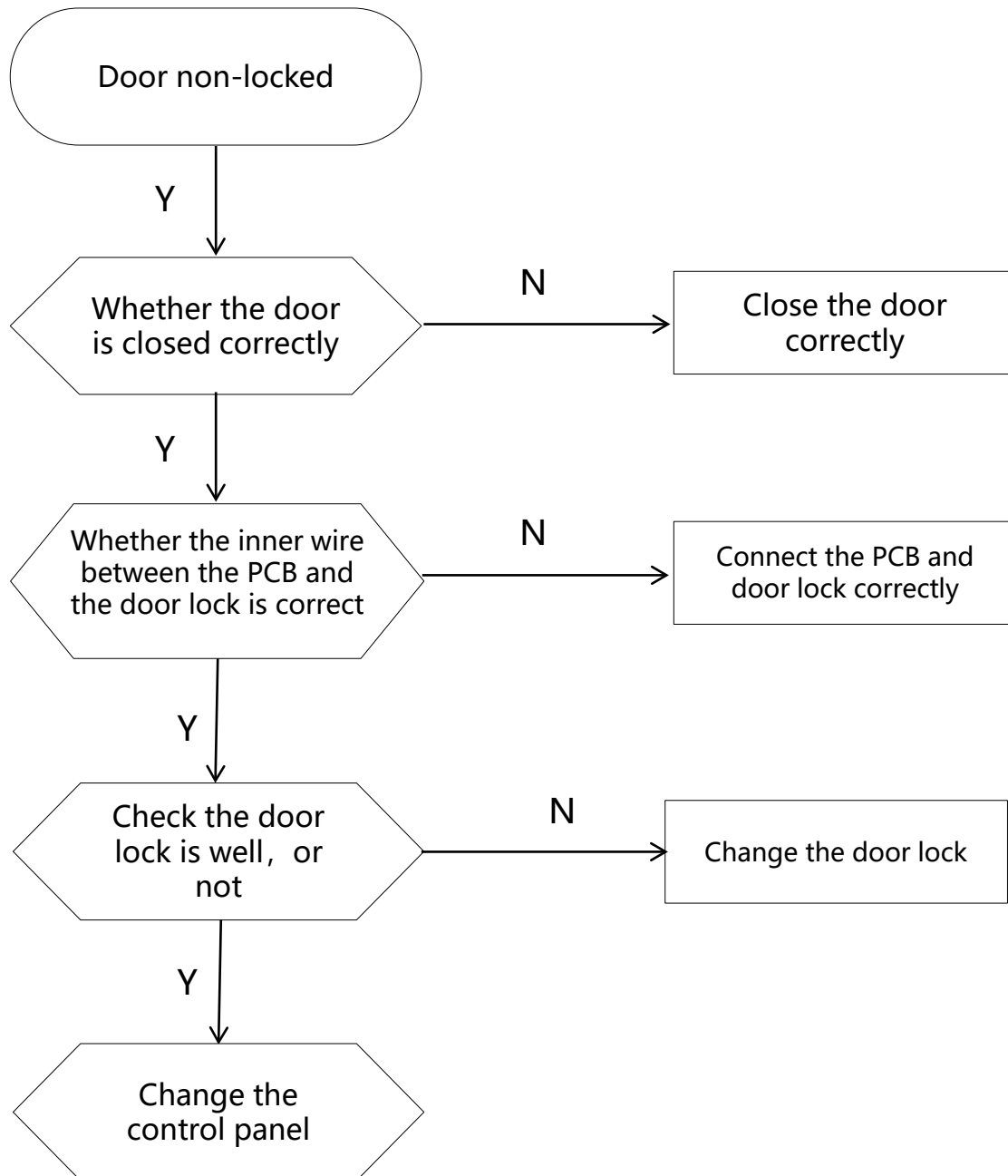

3. No water inlet or water inlet overtime

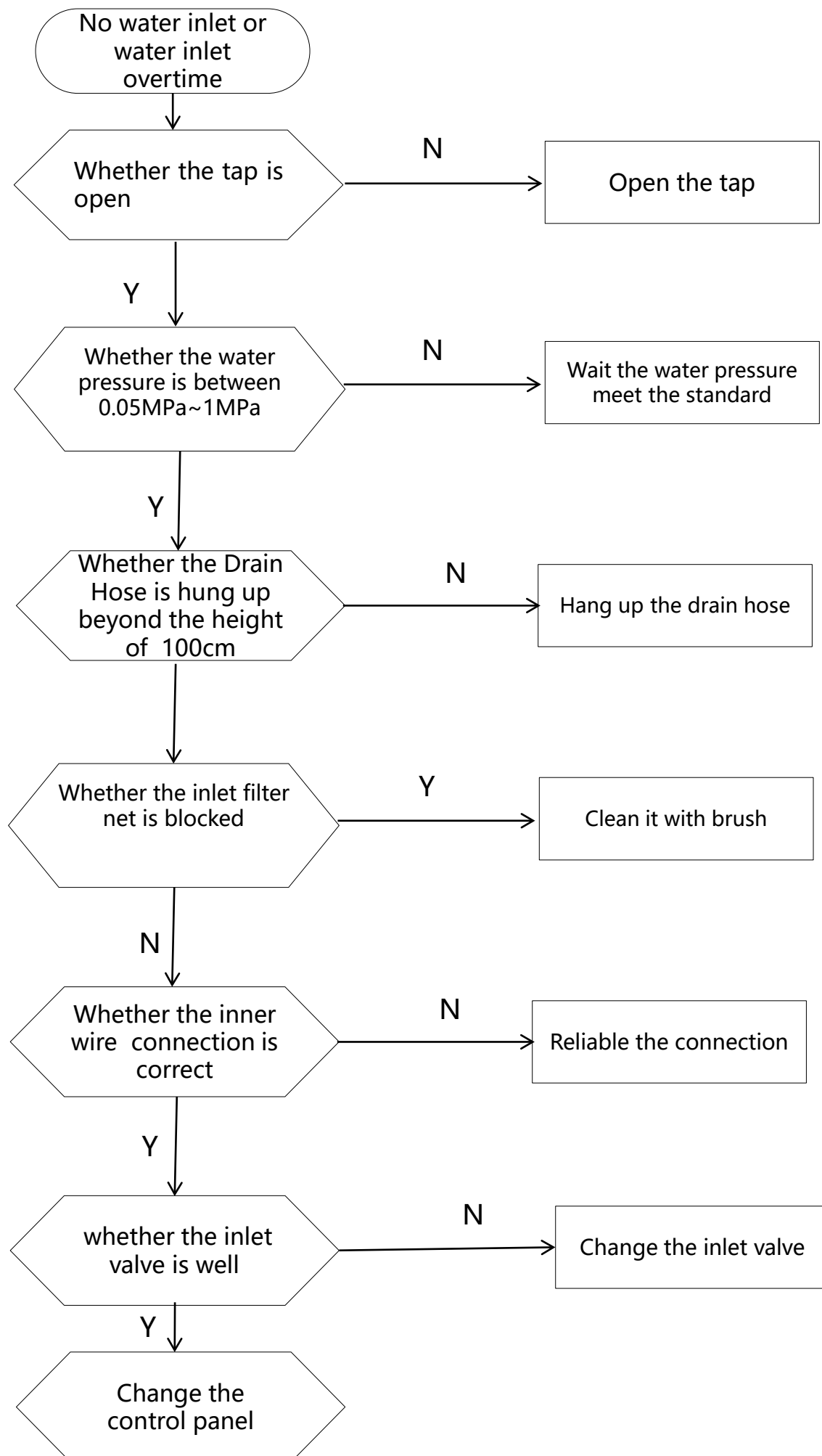

4. Over heating

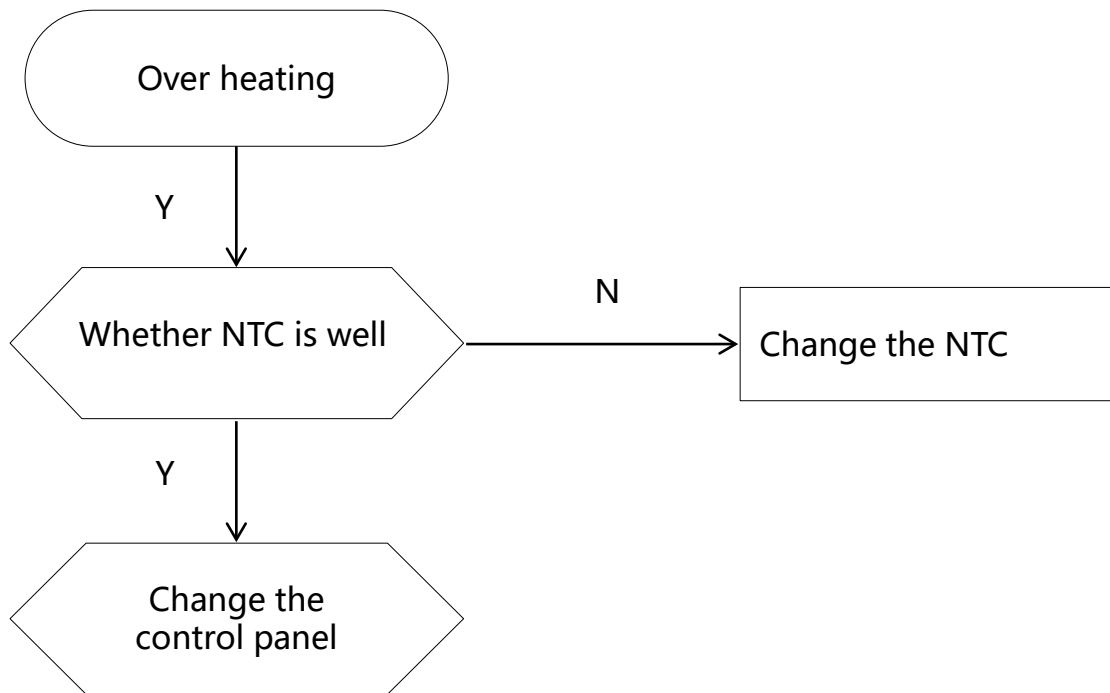

5. Maintenance of non-drain or drain exceed the setting time

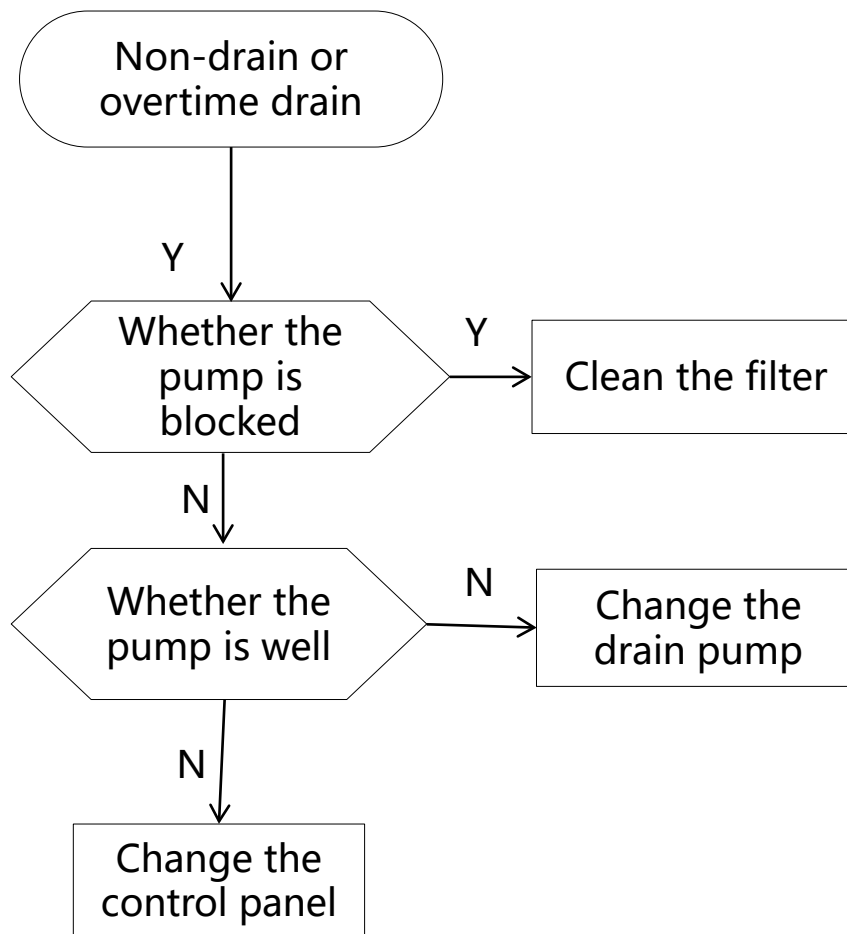

6. Water inlet overflow malfunction maintenance

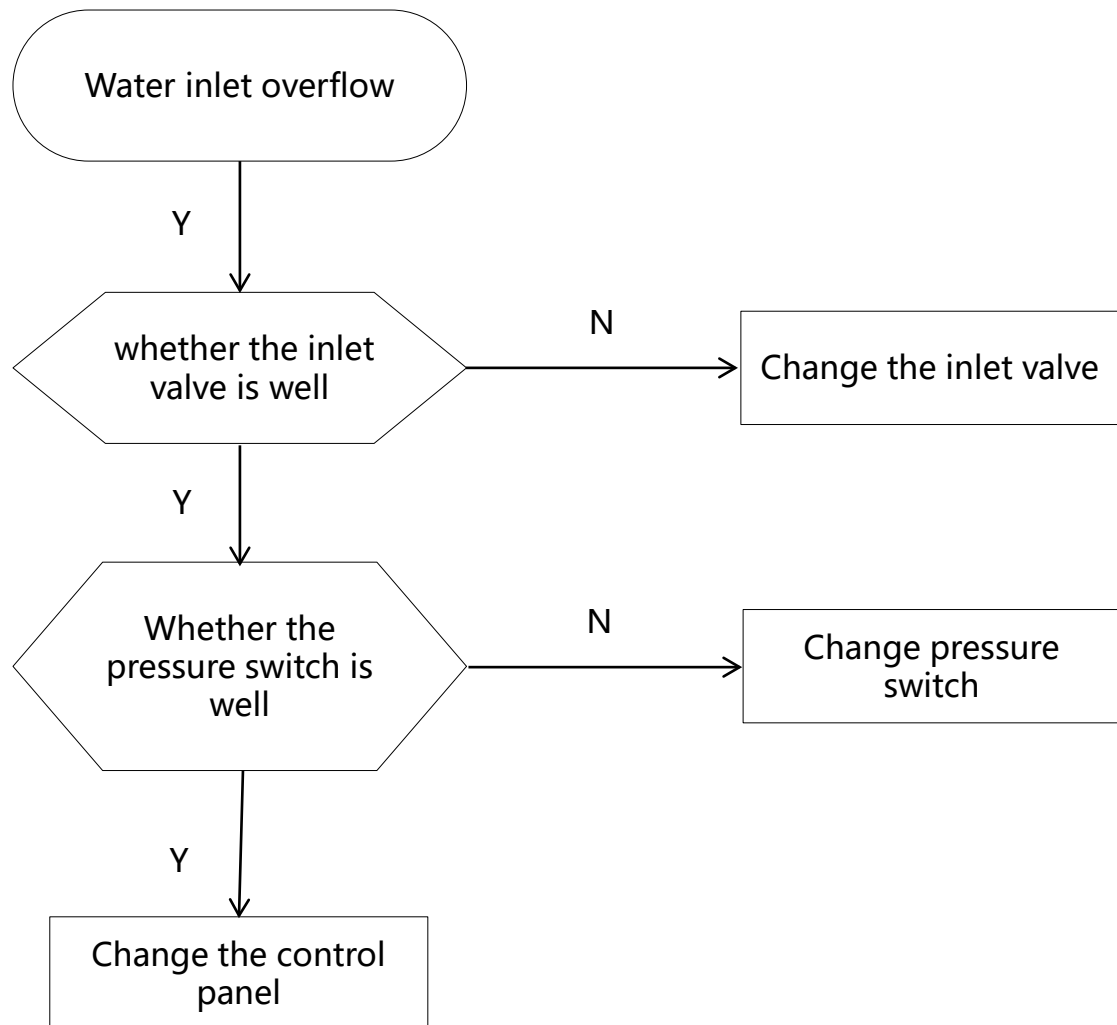

7. Drum non-rotating malfunction maintenance

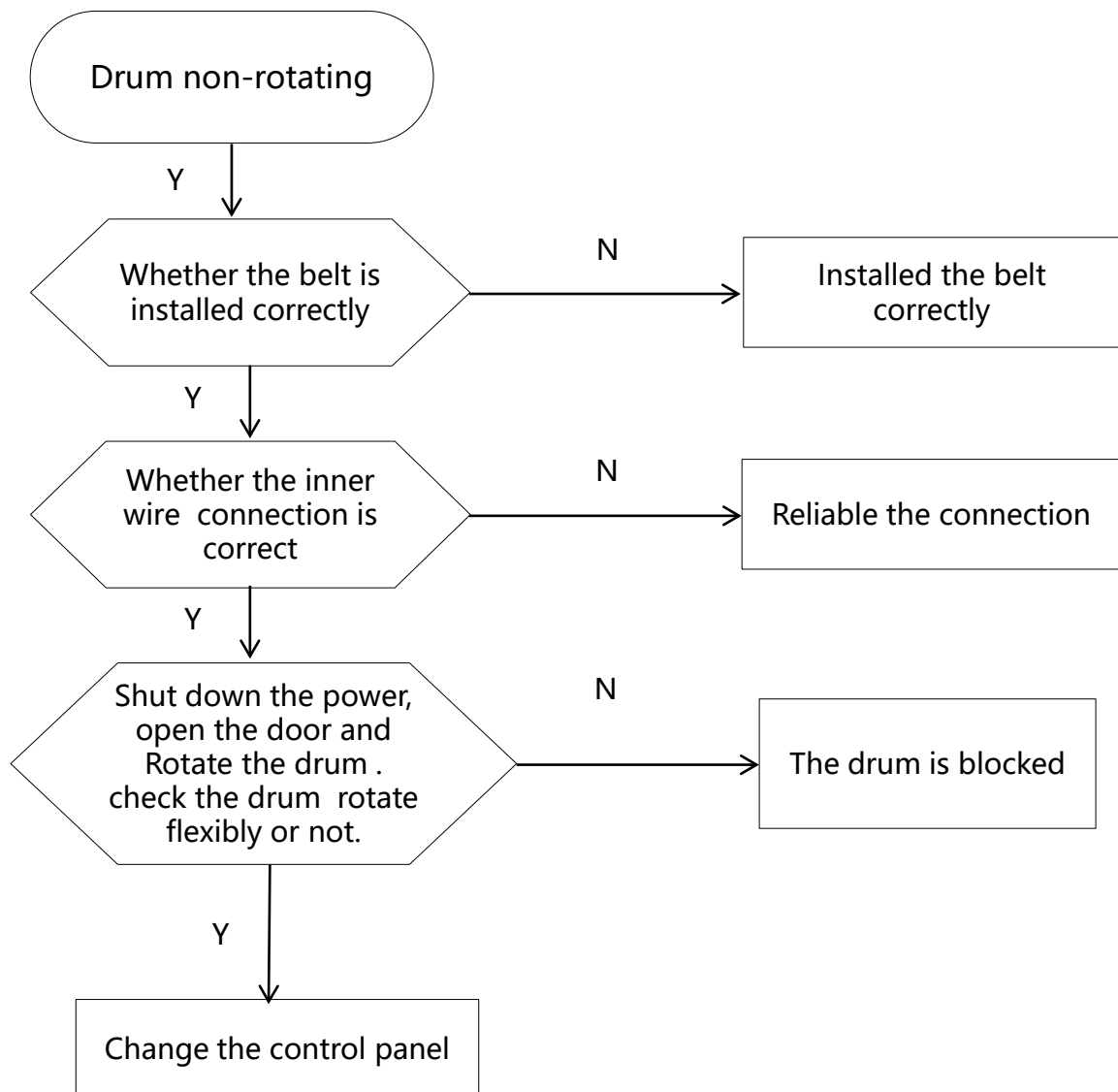

8. Maintenance water inflow and drain off water at the same time

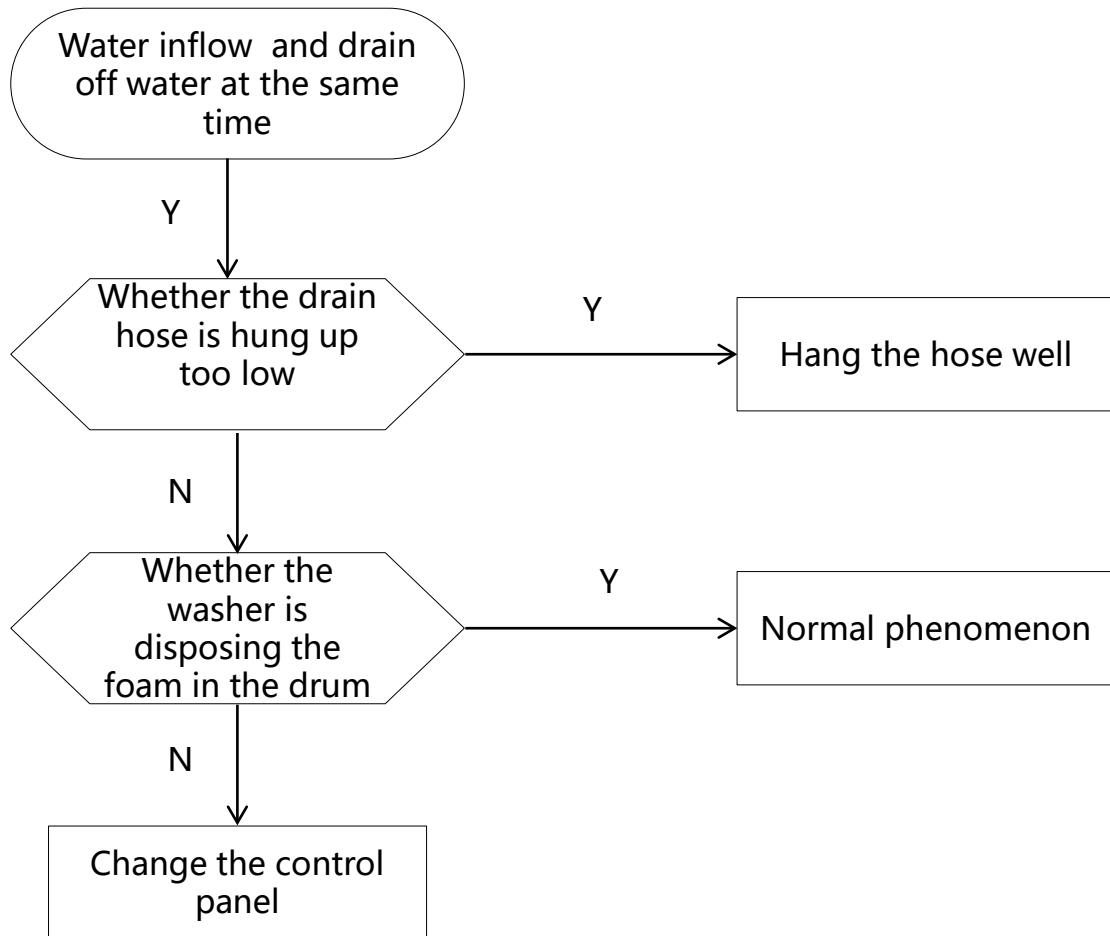

Malfunction and solution

Description	Solution
The washing machine does not work	Close the washing machine's door.
Water leakage	Correctly connect the inlet water pipe.
The speed of the clothes is abnormal	Reload and distribute the laundry evenly in the drum.
There is the peculiar smell in the washing machine	Run a Self clean(Drum clean) cycle without any clothes.
No water is visible in the drum	No fault-water is under the visible area.
There is the remaining water in the softener's box	No fault- the effect of the softener will not be affected.
The remaining detergent is left on the clothes	The water-fast component of the non-phosphorus detergent will be left on the clothes to form the line scale. Please select 【rinse】 or 【spin】 programme or brush away the fleck with the brush when the clothes is dried.
The washing machine does not fill	<p>Open the water tap.</p> <p>Check the selection of the procedure.</p> <p>Check the water.</p> <p>Pressure to see if the water pressure is insufficient.</p> <p>Put through the feed-water.</p> <p>Close the washing machine's door.</p> <p>To check it the inlet water pipe is bent or blocked.</p>
The washing machine fills and empties at the same time.	<p>Make sure the end of the drainage pipe to be higher.</p> <p>Check if the drainage pipe and sewage have been sealed, if they have been, there will be the poor ventilation to cause the sip hon age effect.</p>
No drainage of the washing machine	<p>Check if the drainage pump is blocked.</p> <p>Check if the drainage pipe is bent or blocked.</p> <p>Check the height of the drainage nozzle, make sure it is 0.6-1 meter from the bottom of the washing machine.</p>

<p>Vibration of the washing machine</p>	<p>Level the washing machine. Level the washing machine. Fasten the footing. To check if the internal packing for the transportation have all been removed.</p>
<p>The bubble spills from the detergent</p>	<p>Check if the detergent is excessive, if it is the specialized detergent for the cylinder washing machine. Dip one scoop of the softener mixed with 1/2 liter of water to the detergent box II. Reduce the usage amount of the detergent in the next time's wash.</p>
<p>The machine stops when the procedure has not been finished</p>	<p>Power failure or water cut.</p>
<p>The drainage pump has noise during the operation when the water has just been drained</p>	<p>The inner barrel water of the washing machine has been drained but there is still a small amount of water in the drainage pump and pipe. The drainage pump continuously operates and takes in the air, and at this time there is the noise, which is normal situation.</p>
<p>To stop for some time during the wash procedure</p>	<p>The washing machine adds water automatically. Because there is too much bubble in the tube, the washing machine is cleaning the bubble.</p>
<p>If you cannot solve the above abnormal situations, would you please: 1. To turn the procedure knob to 【OFF】 , pull out the attachment plug; 2. To close the water tap, and contact the nearest service center.</p>	

Before repairing, use multimeter to judge circuit stand of fail.

No	Parts	Picture	Test Description	Parameter	Remarks
1	Water Level Switch		1.Measuring two straight line terminals 2.Measuring two vertical terminals	Break over after blow- PASS	
2	Door lock		Electrify the resistance	2 seconds after the power supply can automatically locked 1-2 mins after the power off can automatically locked- PASS	
3	Water valve		measuring resistance	Resistance value range 3-6K Ω - PASS	
4	Pump		Measure the resistance of the toroids	Resistance value range 150-250 Ω - PASS	
5	Heater		measuring resistance	Resistance value range 20-35 Ω - PASS	
6	NTC		measuring resistance	Resistance value range 4.8k Ω \pm 8% $\text{@}25^{\circ}\text{C}$ 0- PASS	
6	Motor		Measure the resistance of the toroids	Resistance value range PIN5~PIN10 1.3 \pm 10% Ω - PASS	



Number	Tools	Suitable kit
1	Sleeve spanner	Heater 1
		Motor 1 counterweight 5
		Drum tub assembly
		Strap screw
2	Spanner	Adjust pulley screw leg and undo transport bolts
3	Pliers and pinchers	Assembling or auxiliary function
4	Other tools(screwdriver, pliers and so on)	Common service tools