



WMI3005

Caple integrated washing machine



Technical information



WMI3005

Cable integrated washing machine

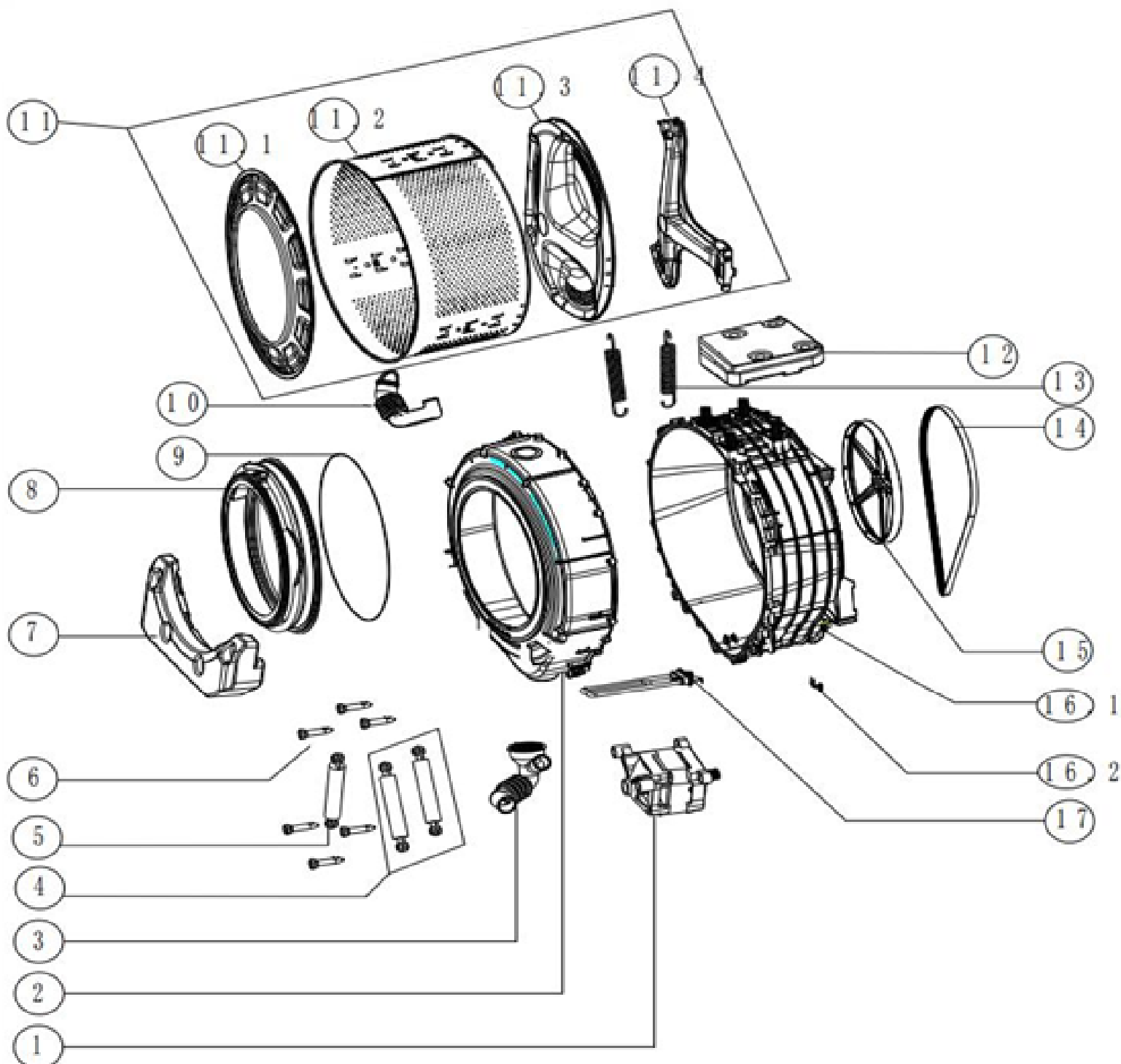

WMI3005

Caple integrated washing machine

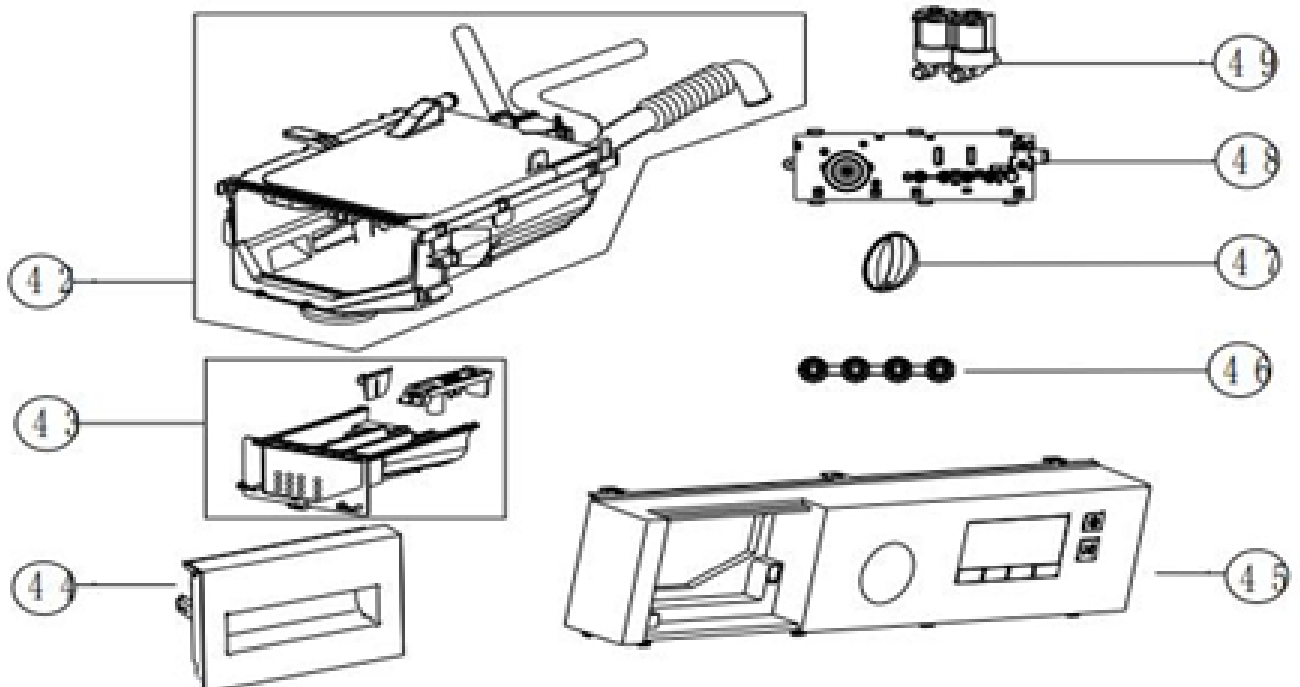
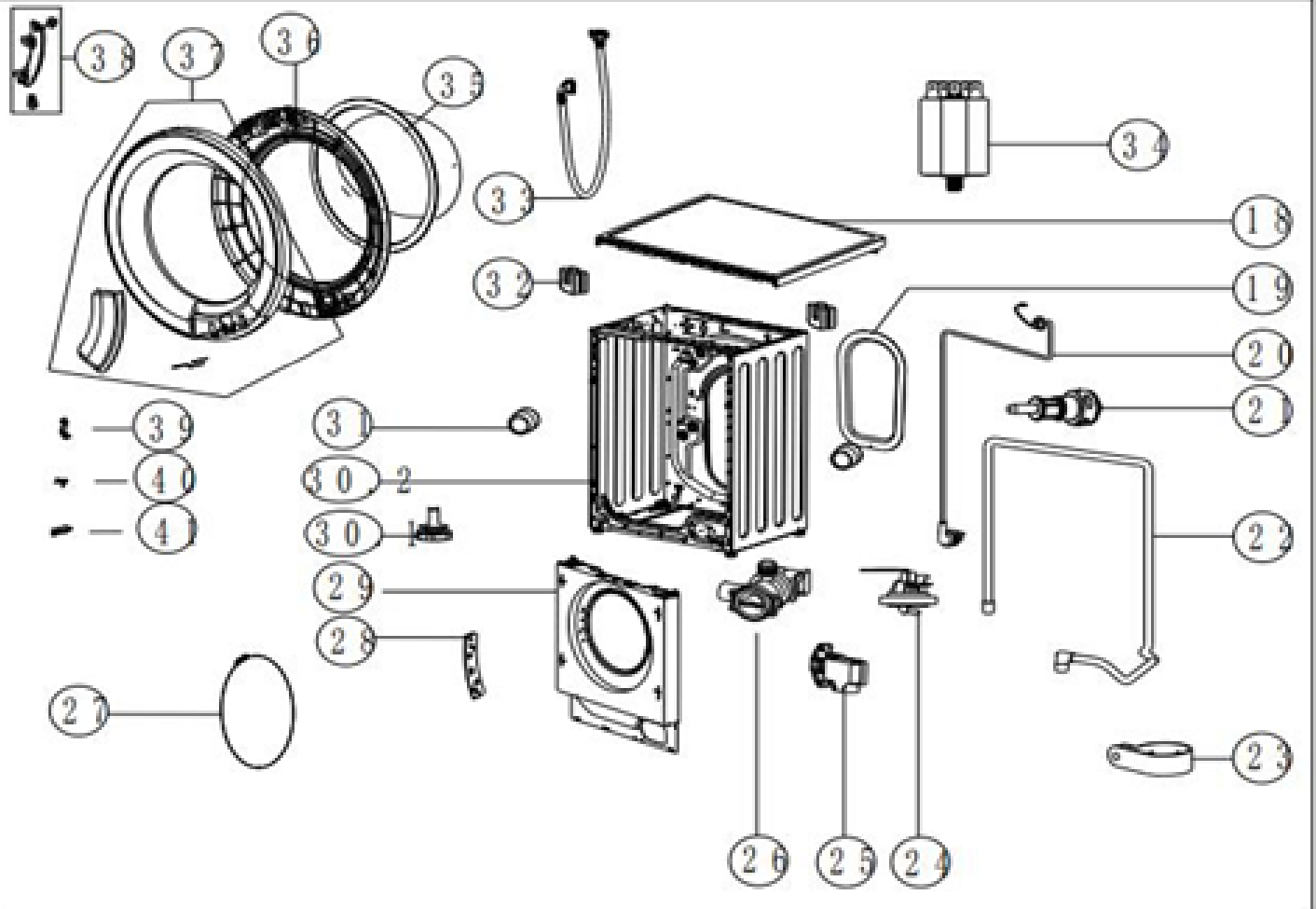



WMI3005 - Caple integrated washing machine

Item	Part Code	Description	Qty
1	11002011000247	Universal motor	1
2	12138100003706	Front Tub	1
3	12638100000488	Tub Drain Hose Assembly	1
4	12938100000469	Damper	1
5	12938100000465	Damper	2
6	12138100002987	Damper Pin	6
7	12738100000008	Lower Counterweight	1
8	12638100000441	Door Gasket	1
9	12938100000016	Door Gasket Clamp	1
10	12638100000278	Tub Water Inlet Hose Assembly	1
11	12238100000523	Basket Assembly	1
11.1	12238100000105	Basket Front Cover	1
11.2	12238100000234	Basket Wrap	1
11.3	12238100000103	Basket Rear Cover	1
11.4	12338100000092	Spider Assembly	1
12	12338100000206	Upper Counterweight	1
13	12900104000017	Suspension Spring	2
14	12338100000148	Pulley	1
15	12638100000250	Belt	1
16	12138100A11183	Rear Tub Assembly	1.0
16.2	12238100000506	Heater Support	1
17	17438100000434	Heater	1
18	12238100001250	Sheetmetal Top Cover	1
19	12238100002053	Rear Cover	1
20	17438100000550	Power Cord	1
21	12938100000062	Shipping Screw Assembly	4
22	12138100007109	Drain Hose Assembly	1
23	12138100003094	Drain Hose Catch	1
24	17438100000120	Water Level Switch	1
25	17438100000456	Door Lock	1
26	11001011000245	Permanent magnet synchronous pump	1
27	12938100000047	Door Gasket Spring Clip Spring	1
28	12238100000401	Door Hinge Assemble Bracket	1
29	12238100002901	Front Panel Assembly	1
30	12238100000267	Cabinet Assembly	1
30.1	12638100000042	Adjustable Foot Assembly	4
30.2	Equal part is not available for	Cabinet	1
31	12138100000337	Front Panel Pin	2
32	12138100003060	Spring Support	2
33	12038100A00008	Water Inlet Hose Assembly	1
34	17438100001354	Electric Filter Assembly	1
35	12538100000006	Door Glass	1
36	12138100006744	Inner Ring	1
37	12138100010732	Outer Frame Assembly	1



WMI3005 - Caple integrated washing machine

Item	Part Code	Description	Qty
38	12338100000185	Hinge Assembly	1
39	12338100000216	Door Plunger	1
40	12900101000243	Twist Spring	1
41	12138100001922	Door Plunger Stand	1
42	12138100003232	Dispenser Subassembly	1
43	12138100008249	Drawer Assembly	1
44	12138100A29910	Drawer Handle And Printing	1
45	12138100A29911	Control Panel Assembly	1
47	12100403000884	Cycle Select Knob	1
48	17138100004434	PCB	1
49	17438100000413	Water Inlet Valve	1

12038100000281 Fixing Kit

12138100A45656 Complete door



Error code For Front-Load Washer					
Error Code	Define	Unit Action	Causes	Explanation	Notes
E10	In 7 minutes, the water level doesn't change with valves open	Unit will close valve and stop with Error code display	Low Water Pressure from House Supply	If the washer fills very slowly, the water pressure from the house might be too low. If the water inlet valve isn't leaking and there are no other symptoms this problem does not need to be corrected.	
			Water inlet hose	Make sure that water faucet is turned on and that the screens on the hoses are not restricted.	
			Water inlet valve (The voltage on the water inlet valve is normal)	.If the water pressure is good, try cleaning the screens inside the water inlet valve hose connection ports. If those are clean replace the water inlet valve	
			Water level sensor or control switch (No voltage on the water inlet valve)	A water lever control switch controls how much water enters the washing machine by PCB. If the water level control switch is defective, or more commonly, if the small air pipe attached to the air bell restricted, The switch will not be able to close the electrical contacts to the washer fill valve.CHECK THE AIR PIPE CHECK THE WATER LEVERL SENSORCHECK THE PCB and the inner wire between PCB and the sensor	
E12	Overflowing	Unit will close valve and stop with Error code display	Restart	Some time just restart the unit can solve the problem.	
			Water inlet valve (The voltage on the water inlet valve is normal)	If the washer is overflowing, the water inlet valve has failed. Replace it.	
			Water level sensor or control switch (No voltage on the water inlet valve)	A water lever control switch controls how much water enters the washing machine by PCB. If the water level control switch is defective, or more commonly, if the small air pipe attached to the air bell restricted, The switch will not be able to close the electrical contacts to the washer fill valve. CHECK THE AIR PIPE CHECK THE WATER LEVERL SENSOR CHECK THE PCB and the inner wire between PCB and the sensor	
E20	Pump open circuit	Unit will close valve and stop with Error code display	Pump	Check the pump or the and the inner wire of the pump	
E21	Washer Won't Drain. Or drain timeout	Unit will close Pump and stop with Error code display	Drain Hose	If the washer won't drain water check the drain hose. Be sure the hose did not get kinked behind the washer. Also, remove the hose from the pump and check it for obstructions.	
			Pump	If the washer won't drain water the drain pump might be defective. It's also common for a small sock or other article of clothing to get caught in the drain pump or in the drain hose. Check both for an obstruction before replacing the pump.	
			PCB	Check PCB	



Error code For Front-Load Washer

Error Code	Define	Unit Action	Causes	Explanation	Notes
E30	Washer Door Won't Lock	Try 6 times , not lock	Door Lock	If the door won't latch, the door lock assembly might be defective. If the door won't latch ,check the door to see if the door is closed before replace it.	
			PCB	If the washer door won't unlock the problem might be the main control board. This is not common. Check the inner wire between the PCB and the door lock.	
E31	Washer Door Won't unlock		Door Lock	If the door won' unlock, the door lock assembly might be defective. If the door won't latch ,check the door to see if the door is closed before replace it.	
			PCB	If the washer door won't unlock the problem might be the main control board. This is not common. Check the inner wire between the PCB and the door lock.	
E33	Water level sensor error	Unit will close valve and stop with Error code display	Water level sensor or control switch (No voltage on the water inlet valve)	E33 means the unit can't detect the Signal of Water level sensor. CHECK THE WATER LEVERL SENSOR CHECK THE PCB and the inner wire between PCB and the sensor	
E40	Memory chip error	/	memory chip broken	Memory chip of the PCB broken, just replace the PCB	
E70	Button get stuck	/	Button get stuck	Re-assemble the control panel.	
E60	The motor don't drive for 5 times	The motor don't drive	/	Check the motor communicate wire Check the PCB and the motor	
E61	The PCB can't get speed transmit signal when the motor drive	The speed don't transmit signal	/	Check the motor communicate wire Check the PCB and the motor	
E62	Triac get broken	The speed don't transmit signal abnormality	/	Check the motor communicate wire Check the PCB and the motor	
E64	(Transducer Error)	Transducer Error	Transducer Error	Check the wire connect before replacing the Transducer	
E50-E5X	(X means different letter or number)	/	Transducer Error	Check the wire connect before replacing the Transducer	
E37	In the drying process, the temperature sensor at the air outlet is wrong	/	Temperature sensor	Check the inner wire before replacing the Temperature sensor	(Outlet and inlet are different with different model)
E38	In the drying process, the temperature sensor at the air intake is wrong	/	Temperature sensor	Check the inner wire before replacing the Temperature sensor	(Outlet and inlet are different with different model)
E3A	Drying heater open	Drying heater open	Drying heater	Push the red part of the temperature sensor before checking. Check the inner wire on PCB, Fan motor heater, temperature sensor. Check the heater resistance (should be a certain value)	
			Lint on fan wheel and condenser	Check and clean the lint on fan wheel. Check the lint in the air condenser.	