



Gas on Glass Hob
Instruction Manual

C775G / C768G / C750G



Contact Caple on 0117 938 7420 for spare parts or www.caple.co.uk

CONTENTS

Introduction	3
Warnings	3
Environmental Protection	11
Warranty	11
Parts of the Appliance	12
How to use Your Appliance	14
Safety & Energy Saving Advice	15
Care and Maintenance	17
Installation Instructions	19
Gas Connection	25
Gas Specification	28
Electrical Connection	29
Gas Adjustment	30
Troubleshooting	32
Technical Specification	33
Notes	34
Caple Contact Details	36

INTRODUCTION

Congratulations on the purchase of your new Caple hob. It is important that you spend some time reading this instruction manual in order to fully understand how to correctly install and operate your hob. For installation, please read the installation section. Read all the safety instructions carefully before using your hob and keep this instruction manual for future reference.

WARNING:

- You **MUST** read these warnings carefully before installing or using the hob.
- This appliance must be installed in accordance with regulations in force and only used in a well-ventilated space.
- Prior to installation, ensure that the gas and electrical supply complies with the type stated on the rating plate.
- This appliance must not be used to heat the room/as a space heater.
- The gas pipe and electrical cable must be installed in such a way that they do not touch any parts or the appliance.

- This appliance is intended to be used in household and similar applications such as:
 - › Staff kitchen areas in shops, offices and other working environments.
 - › Farm Houses.
 - › By clients in hotels, motels and other residential type environments.
 - › Bed and breakfast type environments.
- This appliance is for indoor use only.
- Do not allow children to play near or with the appliance. The appliance gets hot when it is in use.
- Children should be kept away until it has cooled.
- Do not leave children alone or unattended in the kitchen when the hob is in use.
- Only use the appliance for preparing food.
- Do not modify this appliance. The burner panel is not designed to operate from an external timer or separate remote-control system.
- Do not use this appliance if it in contact with water. Do not operate this appliance with wet hands.
- To protect against the risk of electrical shock, do not immerse the unit, cord or plug in water or other liquid.
- Do not use large cloths, tea towels or similar as the ends could touch the flames and catch fire.

- Unstable or misshapen pans should not be used on the appliance as they can cause an accident by tipping or spillage.
- The use of a gas cooking appliance results in the production of heat and moisture in the room in which it is installed. Ensure that the kitchen is well ventilated: keep natural ventilation holes open or install mechanical ventilation device (mechanical extractor hood).
- The heating and cooking surfaces of the appliance become hot when they are in use, take all due precautions.
- Never leave the appliance unattended when cooking.
- Do not use or store flammable materials in the storage drawer near this appliance.
- Perishable food, plastic items and aerosols may be affected by heat and should not be stored above or below the appliance.
- Do not spray aerosols in the vicinity of this appliance while it is in operation.
- Ensure the control knobs are in the '●' position when not in use.
- Never use abrasive or caustic cleaning agents. Clean with warm soapy water and a soft damp cloth.
- This appliance should only be repaired or serviced by an authorised Service Engineer and only genuine Caple approved spare parts should be used.

CAUTION:

- This appliance should be installed by a qualified technician or installer.
- The adjustment conditions for this appliance are stated on the label or rating label.
- Remove all packaging before using the appliance.
- After unpacking the appliance, make sure the product is not damaged and that the electrical cable is in perfect condition. Otherwise, contact the dealer before installing the appliance.
- If the supply cord is damaged, it must be replaced by the manufacturer, its service agent or similarly qualified persons in order to avoid a hazard.
- The adjacent furniture and all materials used in the installation must be able to withstand a minimum temperature of 85°C above the ambient temperature of the room it is located in, whilst in use.
- In the event of burner flames being accidentally extinguished, turn off the burner control and do not attempt to re-ignite the burner for at least one minute.
- The use of a gas cooking appliance results in the production of heat and moisture in the room in which it is installed. Ensure that the kitchen is well ventilated: keep natural ventilation holes open or install a mechanical ventilation device (mechanical extractor hood).

- Prolonged intensive use of the appliance may call for additional ventilation, for example opening of a window, or more effective ventilation, for example increasing the level of mechanical ventilation where present.
- This appliance is designed to be operated by adults.
- Children can injure themselves by pulling pans or pots off the appliance.
- This appliance can be used by children aged from 8 years and above and persons with reduced physical, sensory or mental capabilities or lack of experience and knowledge if they have been given supervision or instruction concerning use of the appliance in a safe way and understand the hazards involved.
- This appliance is not intended for use by children or other persons, whose physical, sensory or mental capabilities or lack of experience and knowledge prevents them from using the appliance safely without supervision or instruction by a responsible person to ensure that they can use the appliance safely.
- This appliance is intended for domestic cooking only. It is not designed for commercial or industrial purposes.
- Prolonged intensive use of the appliance may call for additional ventilation, for example opening of a window, or increasing the level of mechanical ventilation where present.
- Use heat-resistant pot holders or gloves when handling hot pots and pans.

- Do not let pot holders come near open flames when lifting cookware.
- Take care not to let pot holders or gloves get damp or wet, as this causes heat to transfer through the material quicker with the risk of burning yourself.
- Only ever use the burners after placing pots and pans on them. Do not heat up any empty pots or pans.
- Do not place or drop heavy objects on your hob.
- Do not stand on your hob.
- Never use plastic or aluminium foil dishes on the appliance.
- When using other electrical appliances, ensure the cable does not come into contact with the appliance surfaces of the cooking appliance.
- Do not use a tea towel or similar materials in place of a pot holder. Such cloths can catch fire on a hot burner.
- When using glass cookware, make sure it is designed for use on a gas hob. If the surface becomes cracked switch off the hob and let it cool before removing the glass.
- To minimise the possibility of burns, ignition of flammable materials and spillage, turn cookware handles toward the side or centre of the top plate without extending over adjacent burners.
- Always turn burner controls off before removing cookware.
- Carefully watch foods being fried at a high flame setting, they can easily ignite.

- Always heat fat slowly and watch as it heats.
- Foods for frying should be as dry as possible. Frost on frozen foods or moisture on fresh foods can cause hot fat to bubble up and over the sides of the pan.
- Never try to move a pan of hot fat, especially a deep fat fryer. Wait until the fat is cool.
- Before attempting to clean the appliance, it should be disconnected from the mains and cooled.
- You should not use a steam jet or any other high pressure cleaning equipment to clean the appliance.
- Cleaning and user maintenance shall not be made by children without supervision.

WARNING SYMBOLS



Danger/Warning

Neglect of this mark may result in severe personal injury or death.



Caution

Neglect of this mark may result in minor personal injury or property damage.



No naked flames



No Access



Must Do



DANGER

If gas appears to be leaking, take the following actions:

- › Do not turn on the light.
- › Do not switch any electrical appliance on or off and do not touch any electric plug.
- › Do not use a telephone.

1. Stop using the product and close the middle valve.
2. Open the window to ventilate.
3. Contact our service centre or gas supplier by using a phone outside.

* The gas contains mercaptan, so that you can smell the gas leak (smell of rotten garlic or egg) even where only 1/1000 of the gas is in the air.



ENVIRONMENTAL PROTECTION

Waste electrical products should not be disposed of with household waste. Please recycle where facilities exist. Check with your Local Authority or retailer for recycling advice. This appliance is marked according to the European directive on Waste Electrical and Electronic Equipment (WEEE).

By ensuring this product is disposed of correctly, you will help prevent potential negative consequences for the environment and human health, which could otherwise be caused by inappropriate waste handling of this product. The symbol on the product indicates that this product may not be treated as household waste. Instead it shall be handed over to the applicable collection point for the recycling of electrical and electronic equipment. Disposal must be carried out in accordance with local environmental regulations for waste disposal.

For more detailed information about treatment, recovery and recycling of this product, please contact your local council, your household waste disposal service or the retailer where you purchased the product.

CE DECLARATIONS OF CONFORMITY



This appliance has been manufactured to the strictest standards and complies with all applicable legislation, Low Voltage Directive (LVD) and Electromagnetic Compatibility (EMC).

UKCA DECLARATIONS OF CONFORMITY



This appliance has been manufactured to the strictest standards and complies with all applicable legislation.

TECHNICAL FICHE

This appliance conforms to all current and applicable energy regulations. To view the Technical Fiche that supports the energy labelling data, please visit the product page on our website

www.caple.co.uk

WARRANTY

Your new appliance is covered by warranty. The warranty card is enclosed - if it is missing, you must provide the following information to your retailer in order to receive a replacement: date of purchase, model and serial number. Registration can also be completed online by visiting

www.caple.co.uk.

Ensure you keep your warranty card safe, you may need to show it to Caple Service together with proof of purchase.

If you fail to show your warranty card you will incur all repair charges. Spare parts are only available from Caple Service and spare parts authorised centres.

PARTS OF THE APPLIANCE

C775G

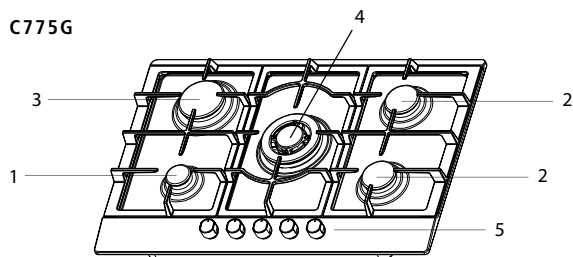

C750G

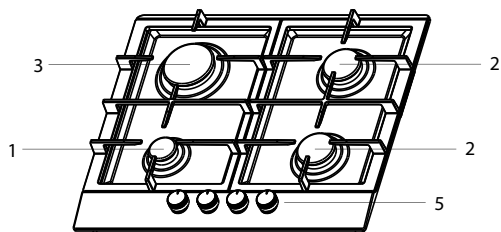

C768G

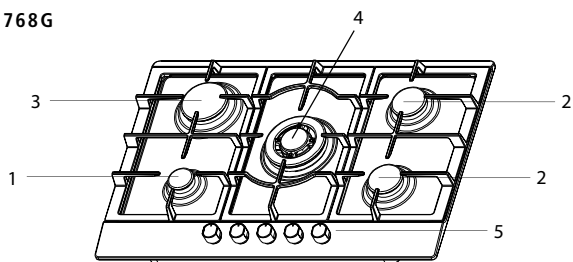

1. Auxiliary gas burner
2. Semi-rapid burner
3. Rapid burner
4. Triple ring burner
5. Control Knobs

ACCESSORIES

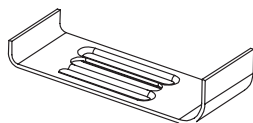

Bracket(4)

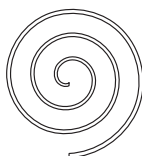

Sponge (4)



Screw (4)



Injector

C775G / C768G (5)
C750G (4)



**Gas-pipe
bend and
washer** (1)



Instruction Manual

HOW TO USE YOUR APPLIANCE

The following symbols will appear on the control panel, next to each control handle:

- Black circle: gas off
- 🔥 Large flame: maximum setting
- 🔥 Small flame: minimum setting

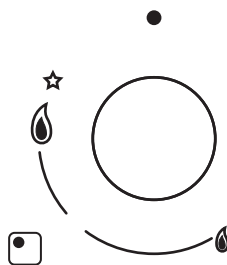

- › The minimum setting is at the end of the anti-clockwise rotation of the control handle.
- › All operation positions must be selected between the maximum and minimum position.
- › The symbol on the control panel, next to the control handle will indicate which burner it operates.

AUTOMATIC IGNITION WITH FLAME FAILURE SAFETY DEVICE

The appliance is fitted with a flame failure safety device on each burner, which is designed to stop the flow of gas to the burner head in the event of the flame going out.

TO IGNITE A BURNER:

- › Press in the control knob of the burner that you wish to light and turn it anti-clockwise to the maximum position.
- › If you keep the control knob depressed, the automatic ignition for the burner will operate.
- › You should hold down the control knob for 15 seconds after the flame on the burner has lit. If after 15s the burner has not lit, stop operating the device and open the compartment door and/or wait at least 1 min before attempting a further ignition of the burner.
- › After this 15-second interval, to regulate the flame you should continue turning the control knob anti-clockwise until the flame is at a suitable level.
- › The operating position **MUST** be at a position between the maximum and minimum position.
- › To switch the burner off, turn the control knob fully clockwise to the gas off position.
- › In case of power failure, the burners can be lit by carefully using a match.

SAFETY AND ENERGY SAVING ADVICE

The diameter of the bottom of the pan should correspond to that of the burner.











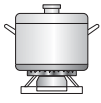

Do not use cookware that overlaps the edge of the burner.

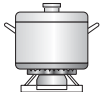
C775G / C768G

BURNERS	REQUIRED PAN SIZE	
	Min.	Max.
Triple-Ring	220mm	260mm
Rapid	180mm	220mm
Semi-Rapid	180mm	200mm
Auxiliary	120mm	180mm

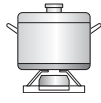
C750G

BURNERS	REQUIRED PAN SIZE	
	Min.	Max.
Triple-Ring	200mm	240mm
Rapid	200mm	240mm
Semi-Rapid	160mm	180mm
Auxiliary	120mm	140mm

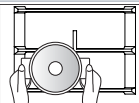
NO		YES	
	Do not use small diameter cookware on large burners. The flame should never come up the sides of the cookware.	Always use cookware that suitable for each burner, to avoid wasting gas and discolouring the cookware.	
	Avoid cooking without a lid or with the lid half off as this wastes energy	Place a lid on the cookware	
	Do not use a pan with a convex or concave bottom.	Only use pots, saucepans and frying pans with a thick, flat bottom.	
	Do not place cookware on one side of a burner, as it could tip over.	Always place the cookware right over the burners, not to one side.	
	Do not use cookware with a large diameter on the burners near the controls, which when placed on the middle of the burner may touch the controls or be so close to them that they increase the temperature in this area and may cause damage.		
	Never place cookware directly on top of the burner.	Place the cookware on top of the trivet.	
	Do not place anything, eg. flame tamer, asbestos mat, between pan and pan support as serious damage to the appliance may result.		
	Do not use excessive weight and do not hit the cooktop with heavy objects.	Handle cookware carefully when they are on the burner.	



It is not recommended to use roasting pans, frying pans or grill stones simultaneously on several burners because the resulting build up of heat may damage the appliance.

Do not touch the top plate and pan supports whilst in use for a certain period after use.









As soon as a liquid starts boiling, turn down the flame so that it will keep the liquid simmering.

CARE AND MAINTENANCE



- › Cleaning operations must only be carried out when the appliance is completely cool.
- › The appliance should be disconnected from your mains supply before commencing any cleaning process.
- › Clean the appliance regularly, preferably after each use.
- › Abrasive cleaners or sharp objects will damage the appliance surface and can remove the symbols. This should be cleaned with a damp cloth, using water and a little washing up liquid. Do not use cream cleaners.

USEABLE	DO NOT USE
 Soft cloth  Neutral Detergent	 Nylon Brush  Edible Oil  Abrasive  Metal Brush  Acidic/Alkali Detergent  Thinner/Benzene

PAN SUPPORTS AND CONTROLS

- › Take off the pan supports.
- › Clean these and the control handles with a damp cloth, washing up liquid and warm water. For stubborn soiling, soak beforehand.
- › Dry everything with a clean soft cloth. It is very important the cast iron pan supports are dried as soon as they have been washed to help prevent corrosion.

HOB TOP

- › Regularly wipe over the top plate using a soft cloth well wrung-out in warm water to which a little washing up liquid has been added.
- › Dry the top plate thoroughly after cleaning.
- › Thoroughly remove salty foods or liquids from the hob as soon as possible to avoid the risk of corrosion.
- › Stainless steel parts of the appliance may become discoloured over time. This is normal because of the high temperatures. Each time the appliance is used these parts should be cleaned with a product that is suitable for stainless steel.

BURNERS

- › Remove the burner lids and Flame Spreaders by pulling them upwards and away from the top plate.
- › Soak them in hot water and a little detergent or washing up liquid.
- › After cleaning and washing them, wipe and dry them carefully. Make sure that the flame holes are clean and completely dry.
- › Wipe the fixed parts of the burner cup with a damp cloth and dry afterwards.
- › Gently wipe the ignition device and flame supervision device with a well wrung-out cloth and wipe dry with a clean cloth.
- › Before placing the burners back on the top plate, make sure that the injector is not blocked.

REASSEMBLE THE AUXILIARY, SEMI-RAPID, RAPID AND TRIPLE-CROWN BURNERS AS FOLLOWS:

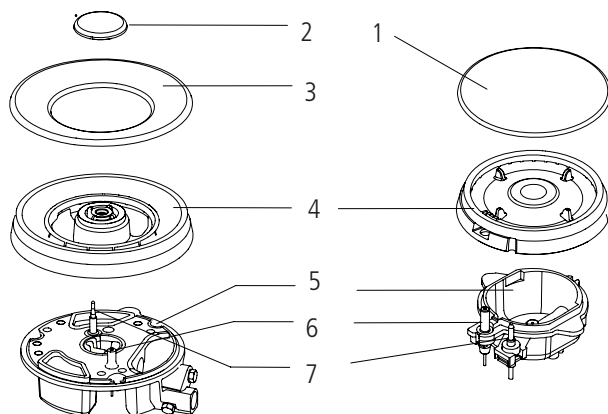

1. Place the flame spreader (4) on to the burner cup (5) so that the ignition device and the flame supervision device extend through their respective holes in the flame spreader. The flame spreader must click into place correctly.
2. Position the burner lid (1,2,3) onto the flame spreader (4) so that the retaining pins fit into their respective recesses.



Replace parts in the correct order after cleaning. Do not mix up the top and the bottom. The locating pins must fit exactly into the notches.

INSTALLATION INSTRUCTIONS



WARNINGS

- › Do not modify this appliance.
- › This appliance must be installed by an authorised technician or installer.
- › Prior to installation, ensure the local distribution conditions (nature of the gas and gas pressure) and the adjustment of the appliance are compatible.
- › The adjustment conditions for this appliance are stated on the label (or Rating Label).
- › This appliance is not connected to a combustion product evacuation device. It should be installed and connected in accordance with current installation regulations. Particular attention should be given to the relevant requirements regarding ventilation.
- › Before installing, turn off the gas and electricity supply to the appliance.
- › All appliances containing any electrical components must be earthed.
- › Ensure that the gas pipe and electrical cable are installed in such a way that they do not touch any parts of the appliance which may become hot.
- › The gas pipe or connector shouldn't be bent or blocked by any other appliances.
- › Check the dimensions of the appliance as well as the dimensions of the gap to be cut in the kitchen unit.
- › The panels located above the work surface, directly next to the appliance, must be made of non-flammable material. Both the work surface and the glue used to secure it should be heat resistant, to prevent deterioration.
- › Turn on the appliance tap and light each burner. Check for a clear blue flame without yellow tipping. If the burners show any abnormalities check the following:
 - Burner lid is on securely.
 - Flame spreader is positioned correctly.
 - Burner is vertically aligned with injector nipple.
- › A full operational test and a test for possible leakages must be carried out by the fitter after installation.
- › The flexible hose shall be fitted in such a way that it cannot come into contact with a moveable part of the housing unit and does not pass through any space susceptible of becoming congested. The hose must be manufactured in accordance with BS669 part 1 and be of the correct construction for the type of gas being used. Gas hoses designed for natural gas MUST NOT be used for supplying LPG gas (LPG gas hoses can be identified by either a red band or stripe on the rubber outer coating of the hose).
- › The installation must confirm to all current installation standards and regulations in force.

IMPORTANT NOTE:

It is a legal requirement that all gas appliances are Installed & Serviced by a competent person in accordance with the current editions of the following Standards & Regulations or those regulations appropriate to the geographical region in which they are to be installed:

- › Gas Safety (Installation & Use) Regulations
- › Building Regulations
- › British Standards
- › Regulations for Electrical Installation

Installation and service of any gas product must be made by a suitably qualified person competent on the type of product being installed or serviced and holding a valid certificate of competence for the work being carried out. Currently the proof of competence is the Accredited Certification Scheme (ACS) or S/NVQ that has been aligned to the ACS. It is also a requirement that all businesses or self employed installers are members of a class of person approved by the Health and Safety Executive. Failure to install the appliance correctly could invalidate any manufacturer's warranty and lead to prosecution under the above quoted regulation.

POSITIONING (C775G)

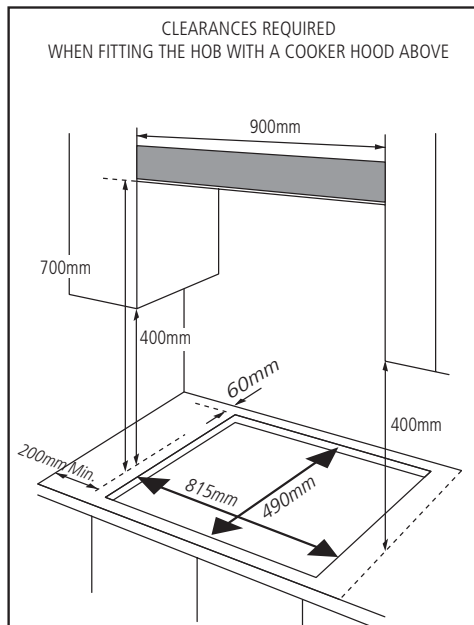
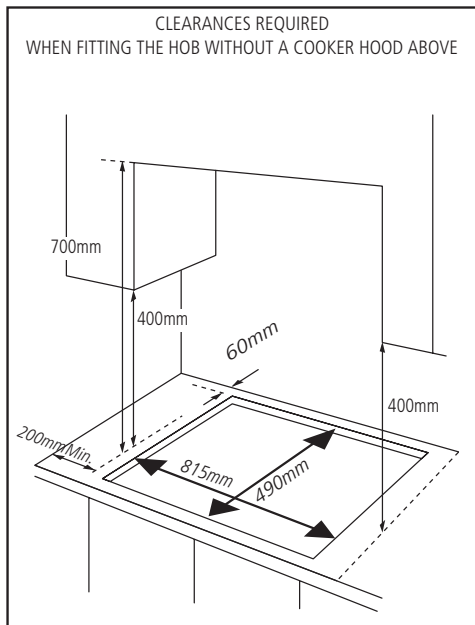

POSITIONING (C750G)

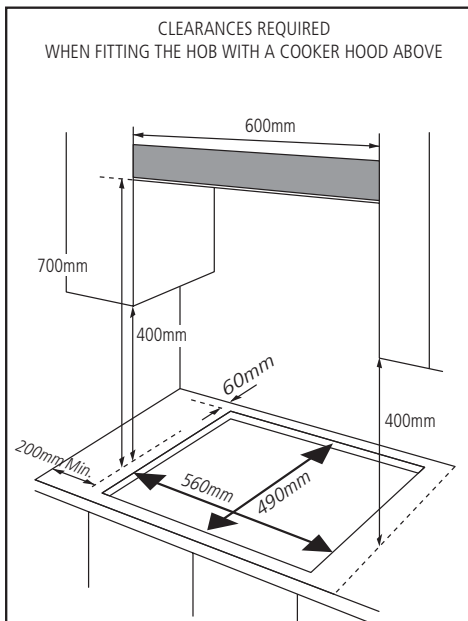

POSITIONING (C768G)

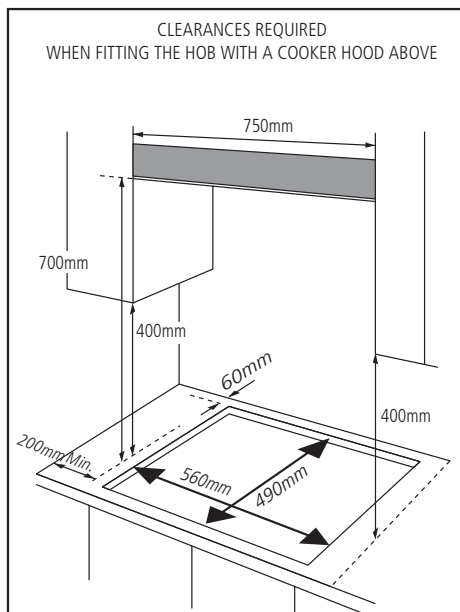
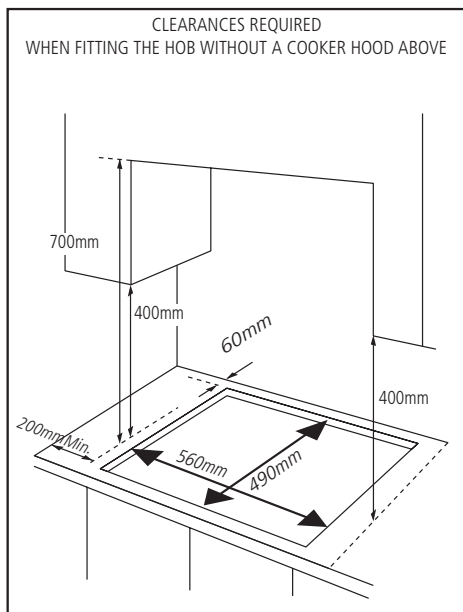

This appliance is to be built into a kitchen unit or 600mm worktop, providing the following minimum distances are allowed:

- › The edges of the hob must be a minimum distance of 60mm from a side or rear wall.
- › 700mm between the highest point of the hob surface (including the burners) and the underside of any horizontal surface directly above it.
- › 400mm between the hob surfaces, providing that the underside of the horizontal surface is in line with the outer edge of the hob. If the underside of the horizontal surface is lower than 400mm, then it must be at least 50mm away from the outer edges of the hob.
- › 50mm clearance around the appliance and between the hob surface and any combustible materials.
- › You must have a gap of at least 25mm and at most 74mm between the underneath of the appliance and any surface that is below it.

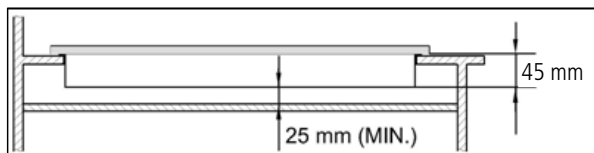

- › An oven must have forced ventilation to install a hob above it.
- › Check the dimensions of the oven in the installation manual.
- › The cut out size must be as shown in the drawing relevant to the model being installed.

INSTALLING THE APPLIANCE

1. Remove the pan supports, the burner lid and flame spreader and carefully turn the appliance upside down and place it on a cushioned mat. Take care that the Ignition devices and flame supervision devices are not damaged in this operation.
2. Apply the sponge provided around the edge of the appliance.
3. Do not leave a gap in the sealing agent or overlap the thickness.



Do not use a silicon sealant to seal the appliance against the aperture.

This will make it difficult to remove the appliance from the aperture in future, particularly if it needs to be serviced.

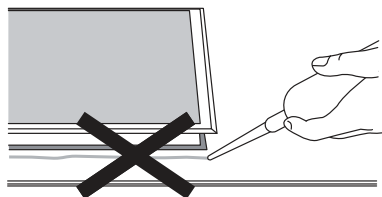

1. Place the bracket (B) over the holes that match the size of the screws. There are one set of screw holes in each corner of the hob (H). Slightly tighten a screw (C) through the bracket (B) so that the bracket is attached to the hob, but so that you can still adjust the position.
2. Carefully turn the hob back over and then gently lower it into the aperture hole that you have cut out.
3. On the underneath of the hob, adjust the brackets into a position that is suitable for your worktop.
4. Then fully tighten the screws (C) to secure the hob into position.

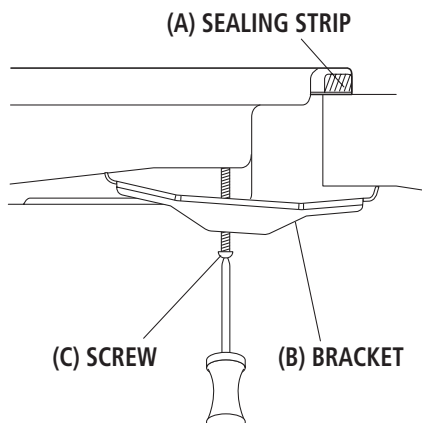

GAS CONNECTION

IMPORTANT

- › This appliance must be installed and connected in accordance with the installation regulations in force.
- › This appliance is supplied to run on natural gas and LPG. Conversion for use on LPG and natural gases must only be undertaken by a qualified person.
- › The gas inlet is at the rear RH side of the hob. The hob should be connected to the gas supply by rigid pipework as per the regulations in force.

NOTE:

Wear protective gloves to fit the hob.

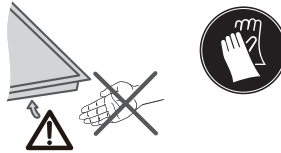

GAS SUPPLY REPLACEMENT AND INSTALLATION GUIDELINES

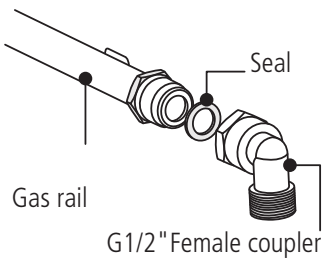

IMPORTANT :

The elbow connection has been installed and leaked checked at the factory.

If it is necessary to adjust the direction of the elbow then the installer must use a torque wrench with **9±1N*m**.

Excessive torque may break or fracture the elbow. Responsibility will lie with the installer.

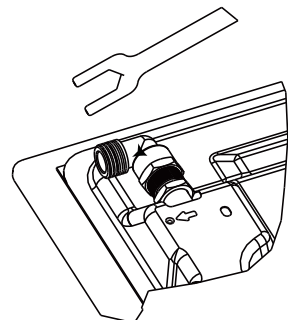

ADJUSTING THE DIRECTION OF THE ELBOW

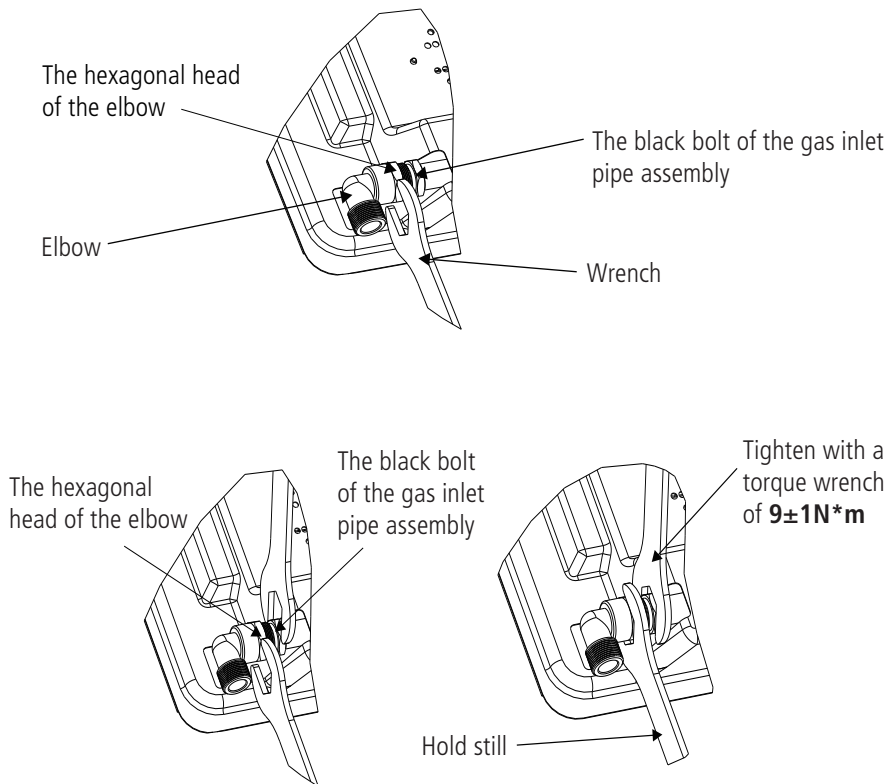

After loosening the elbow, adjust the elbow interface to the required direction and keep the hexagonal head of the elbow motionless with a wrench. Use a $9\pm 1\text{N}\cdot\text{m}$ torque wrench to tighten the black bolt of the gas inlet pipe assembly. Ensure that the torque of the wrench is within the required range to prevent elbow breakage or damage caused by excessive force. A full operational test and a test for possible leakages must be carried out by the fitter after installation.

WARNING:



Danger of leaks

If any connection is handled, check the seal.

The manufacturer is not liable for any connection leaking after being handled.

It is the law that all gas appliances are installed by competent persons in accordance with the current edition of the Gas Safety Installation and Use Regulations.



It is in your interest and that of safety to ensure compliance with the law.

In the UK, GASSAFE registered installers work to safe standards of practice. The hob must also be installed in accordance with the current edition of BS 6172. Failure to install the cooker correctly could invalidate the warranty, liability claims and lead to prosecution.

GAS CATEGORY, GAS TYPE AND DESTINATION COUNTRY (FOR ALL MODELS)

I ₃₊ (28-30/37)	G30 Butane at 28-30mbar and G31 Propane at 37mbar	BE, CH, CY, CZ, ES, FR, GB, GR, IE, IT, LT, LU, LV, PT, SK, SI
I _{3B/P(30)}	G30 Butane and G31 Propane at 30mbar	BE, CY, DK, EE, GB, HU, IT, LT, NL, NO, SE, SI, SK, RO, HR, TR, BG, IS, LU, MT, FI
I _{2H/I_{2E}/I_{2E+}}	G20 Methane at 20mbar	AT, CH, CZ, DK, ES, FI, GB, GR, IE, IS, IT, PT, SE, SI, SK, DE, LU, GE, FR
II _{2H3+}	G20 at 20mbar, G30 Butane at 28-30mbar and G31 Propane at 37mbar	CH, CZ, ES, GB, GR, IE, IT, PT, SI
II _{2H3B/P(30)}	G20 at 20mbar, G30 Butane and G31 Propane at 30mbar	CH, CZ, DK, FI, GR, SE, SI, SK
II _{2E+3+}	G20/G25 at 20/25mbar, G30 Butane at 28-30mbar and G31 Propane at 37mbar	BE, FR
II _{2H3B/P}	I2H: G20 Methane at 20mbar I3B/P: G30 butane and G31 propane at 30mbar	CH, CZ, DK, FI, GR, SE, SI, SK
II _{2H3+}	I2H: G20 Methane at 20mbar I3+: G30 butane at 30mbar and G31 propane at 37mbar	CH, CZ, ES, GB, GR, IE, IT, PT, SI
II _{2E+3+}	I2E: G20 Methane at 20mbar I3+: G30 butane at 30mbar and G31 propane at 37mbar	BE, FR,

GAS SPECIFICATION

MODEL NO.	Gas type & pressure	Electrical power	Heat input and orifice size marked (mm)					Total Heat input
			Triple-Crow burner	Rapid burner	Semi-rapid	Semi-rapid	Auxiliary-rapid	
C768G & C775G			3.3kW(241g/h)	3.0kW(219g/h)	1.75kW(127g/h)	1.75kW(127g/h)	1.0kW(73g/h)	10.8kW(787g/h)
	G20 20mbar	230V~50Hz	1.28	1.30	1.0	1.0	0.78	N/A
	G30 29mbar	230V~50Hz	0.93	0.87	0.66	0.66	0.50	N/A

MODEL NO.	Gas type & pressure	Electrical power	Heat input and orifice size marked (mm)				Total Heat input
			Work burner	Rapid burner	Semi-rapid	Auxiliary-rapid	
C750G			3.3kW(241g/h)	3.0kW(219g/h)	1.75kW(127g/h)	1.0kW(73g/h)	7.5kW(546g/h)
	G20 20mbar	230V~50Hz	/	1.30	1.0	0.78	N/A
	G30 29mbar	230V~50Hz	/	0.87	0.66	0.50	N/A

ELECTRICAL CONNECTION

- › This appliance must be earthed.
- › This appliance is designed to be connected to a 230V, 50Hz AC electricity supply.
- › The wires in the mains lead are coloured in accordance with the following code:
 - Green/yellow = Earth
 - Blue = Neutral
 - Brown = Live



The wire that is coloured green and yellow must be connected to the terminal which is marked with the letter E or by the earth symbol.



WIRING DIAGRAM

C775G / C768G

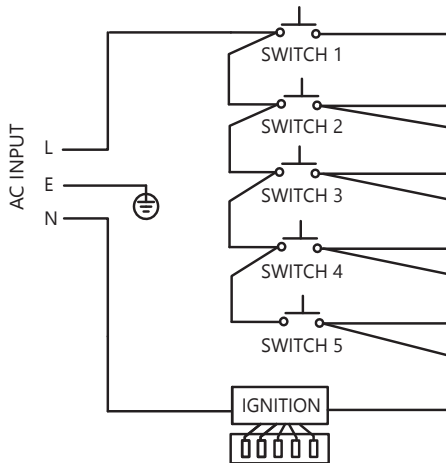

C750G

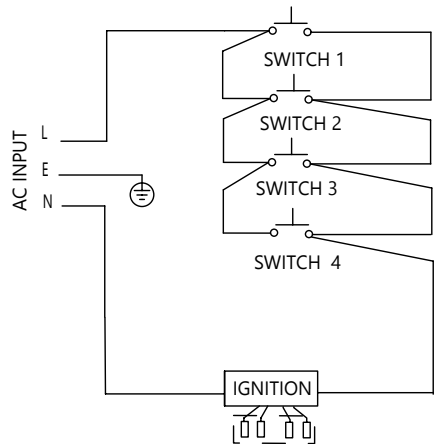

If the mains cable is damaged it must be replaced by the manufacturers authorised customer service agent or similarly qualified personnel. Contact Caple Service on 0117 938 7420 or by email service@caple.co.uk.

GAS ADJUSTMENT



Take precautions on the operations and adjustments to be carried out when converting from one gas to another.

All work must be carried out by a qualified technician.

Before you begin, turn off the gas and electricity supply to the appliance.

CHANGE THE INJECTOR OF THE BURNERS

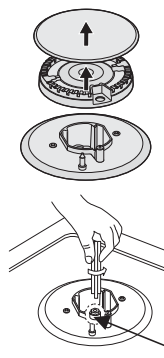

Remove the pan support, Burner lid and Flame spreader.

Unscrew the injector using a 7mm box spanner and replace it with the stipulated injector for new gas supply.

Carefully reassemble the all components.

After injectors are replaced, it is advisable to strongly tighten the injector in place.

ADJUSTMENT OF THE MINIMUM LEVEL OF THE FLAME

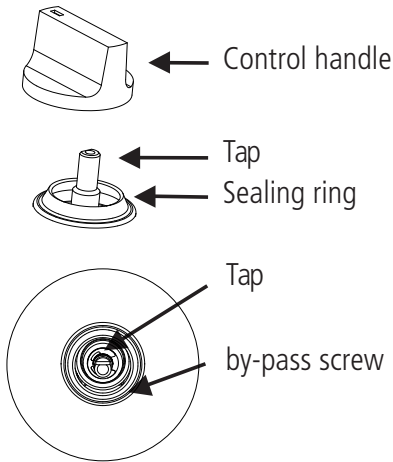

1. Turn the taps down to minimum.
2. Remove the knob from the tap and place a small bladed screwdriver in the centre of the tap shaft.
3. The correct adjustment is obtained when the flame has a length of about 3-4mm. For butane/propane gas, the adjusting screw must be tightly screwed in.
 - › Refit the control knob.
 - › Make sure that the flame does not go out by quickly turning from maximum flow to minimum flow. If it does, then remove the control knob and make further adjustments to the gas flow, testing it again once the adjustment has been made.
4. Repeat this process for each one of the gas taps.



Do not dismantle the tap shaft: in the event of a malfunction, change the whole tap.

Before placing the burners back on top, make sure the injector is not blocked.

A full operational test and a test for possible leakages must be carried out after the gas conversion (such as soap water or a gas detector).

After completing the conversion, a qualified technician or installer must mark 'V' next to the correct gas category to match with the setting on the Rating Label. Make sure to remove the previous 'V' mark.

TROUBLESHOOTING

Repairs should be performed by a licensed technician only. Improper repair may result in considerable danger to you and others.

PROBLEM	CAUSE	SOLUTION
Not igniting	No Spark.	Check the electricity supply.
	The burner lid is badly assembled.	Assemble the lid correctly.
	The gas supply is closed.	Open the gas supply completely.
Badly ignited	The gas supply is not completely open.	Open the gas supply completely.
	The burner lid is badly assembled.	Assemble the lid correctly.
	The ignition plug is contaminated with alien substance.	Wipe alien substance with a dry cloth.
	The burners are wet.	Dry the burners lids carefully.
	The holes in the flame spreader are clogged.	Clean the flame spreader
Noise made when combusted and ignited	The burner lid is badly assembled	Assemble the burner lid correctly.
Flame goes out when in use.	The flame supervision device is contaminated with an alien substance.	Clean the flame supervision device.
	Product being cooked has boiled over and extinguished the flame.	Turn off burner knob. Wait one minute and reignite zone.
	A strong draught may have blown the flame out.	Please turn off zone and check cooking area for draught such as open windows. Wait one minute and reignite zone.
Yellow Flame	The holes in the flame spreader are clogged.	Clean the flame spreader.
	Different gas is used.	Check the gas used.
Unstable Flame	The burner lid is badly assembled.	Assemble the burner lid correctly.
Gas Smell	Gas leakage.	Stop using the product and close the middle valve. Open the window to ventilate. Contact our service centre by using a phone outside.

If the problem cannot be solved, please contact Caple Service on 0117 938 7420 or email service@caple.co.uk.

TECHNICAL SPECIFICATION

	C775G	C750G	C768G
PAN SUPPORT	Cast Iron	Cast Iron	Cast Iron
TOP PLATE	Stainless Steel	Stainless Steel	Stainless Steel
PRODUCT SIZE LXWXH(mm)	860 X 510 X 54	594 x 514 x 51	750 X 510 X 50
IGNITION DEVICE	Continuous Ignition Type	Continuous Ignition Type	Continuous Ignition Type
GAS CONNECTION	G 1/2 thread	G 1/2 thread	G 1/2 thread
ELECTRIC SUPPLY	230Vac, 50Hz, 2W	230Vac, 50Hz, 2W	230Vac, 50Hz, 2W
TOTAL COMBINED GAS OUTPUT	10.8kW	7.5kW	10.8kW



NOTES

NOTES



Caple Service

Fourth Way

Avonmouth

Bristol

BS11 8DW

T: 0117 938 1900

E: service@caple.co.uk

www.caple.co.uk