

Gas hob instruction manual

C767G



CONTENTS

Safety Warnings	3
Installation Warnings	7
Environmental Protection	9
Warranty	9
Instructions For The User	10
Cleaning	12
Instructions For The Installer	14
Maintenance	18
Gas Specification	19
Energy Saving Tips	19
Dimensions	20
Trouble Shooting	21

SAFETY INSTRUCTIONS

Read these instructions carefully and completely before using your appliance, keep it in a convenient place for reference when necessary.

- If gas appears to be leaking, take the following actions:
 - Do not turn on the light.
 - Do not switch any electrical appliances on or off and do not touch any electrical plugs.
 - Do not use a telephone.
 - Stop using the product and close the middle valve.
 - Open windows to ventilate.
 - Contact Cable Service and your gas supplier.
- This appliance can be used by children aged from 8 years and above.
- Persons with reduced physical, sensory or mental capabilities or lack of experience and knowledge must be supervised and given appropriate instruction concerning the use of the appliance in a safe way and understand the hazards involved.
- Children shall not play with the appliance.
- Cleaning and user maintenance should not be carried out by children without supervision.
- The appliance is not intended to be operated by means of an external timer or separate remote control system.

WARNING:

- This appliance is designed for cooking food and is intended for indoor domestic household use only.
- The appliance and its accessible parts become hot during use. Care should be taken to avoid touching heating elements.
- Children less than 8 years of age should be kept away unless continuously supervised.
- Unattended cooking on a hob with fat or oil can be dangerous and may result in fire. **NEVER** try to extinguish a fire with water, but switch off the appliance and then cover flame e.g. with a lid or a fire blanket.
- **DANGER of FIRE:** do not store items on the cooking surfaces.
- Don't use a steam cleaner for cleaning the hob.
- If the surface is cracked, switch off the appliance to avoid the possibility of electric shock.
- **DANGER** of burning or scalding. Place pots and pans on the cooking zone in such a way that children cannot pull them down and burn themselves.

CAUTION:

- Carefully read the instructions before installing and using the appliance. The manufacturer cannot be held responsible if improper installation or use of the device causes injury or damage. Keep the instructions handy as a reference for the future.
- Do not use the hob during cleaning
- Never leave the appliance unattended during food preparation because oil and grease could cause a fire.
- When the unit is connected directly to the power supply, you need a switch insulating omnipolar.
- If the switched socket is not accessible after installation, or if the appliance is to be hard-wired, an additional means of disconnection must be provided for all poles. When switched off, there must be an all-pole contact gap of at least 3mm in the switch (including switch, fuses and relays). Connection data is shown on the data plate. It must match the mains electrical supply. After installation ensure that all electrical components are shielded and cannot be accessed by users.
- The earth cable is not included.
- If the power cable is damaged, it must be replaced by the manufacturer, by an authorised technician or by a qualified person to avoid danger.

- When connecting the power cable, make sure it is not in direct contact (e.g. through the use of insulation sleeves) with parts that can reach temperatures of over 85°C.
- Do not spray aerosols in the vicinity of this appliance while it is in operation.
- Perishable food, plastic items and aerosols may be affected by heat and should not be stored above or below the appliance.
- Due to the high temperatures radiated, objects left near the hob when it is used could catch fire. Do not use the hob to heat up the room.
- Flames could set the grease filters of a cooker hood on fire. Do not flambé under a cooker hood.
- Spray canisters, aerosols and other inflammable substances can ignite when heated. Therefore do not store such items or substances in a drawer under the hob. Cutlery inserts must be heat-resistant.
- Do not heat an empty pan.
- Do not heat up food in closed containers e.g. tins or sealed jars on the hob, as pressure can build up in the container, causing it to explode.
- Do not cover the hob, e.g. with a hob cover, a cloth or protective foil. The material could catch fire, shatter or melt if the hob is switched on by mistake or if residual heat is still present.

Please keep this instruction manual for future reference

INSTALLATION WARNINGS

- The installation must be carried out by experienced and qualified personnel, in conformity with the regulations in force.
- Connection to the gas supply must be carried out by a suitable qualified gas fitter (e.g. a Gas Safe registered technician in the UK).
- Prior to installation, ensure that the gas and electrical supply complies with the type stated on the rating plate.
- This appliance is not intended for use by person (including children) with reduced physical, sensory or mental capabilities, or lack of experience and knowledge, unless they have been given supervision or instruction concerning use of the appliance by a person responsible for their safety. Children should be supervised to ensure that they do not play with the appliance.
- Before powering the equipment, check that it is properly adjusted for the type of gas available.
- Before carrying out maintenance or cleaning of the equipment, turn the power supply off and ensure the hob is not hot.
- Make sure that air circulates around the gas equipment in accordance with regulations in force and only used in a well ventilated space.

Please keep this instruction manual for future reference

- Insufficient ventilation produces a lack of oxygen.
- In case of an intense or prolonged use of the equipment, it may be necessary to improve aeration, for example by opening a window or increasing the extraction power of your extractor hood, if it exists.
- The products of combustion must be discharged outside through an extractor hood or an electric fan.
- For any possible repair or modification, contact Caple Service directly for help, and ensure only original spare parts are used.
- The rating label, with the serial number and model number included, is stuck on the underside of the hob.



ENVIRONMENTAL PROTECTION

Waste electrical products should not be disposed of with household waste. Please recycle where facilities exist. Check with your Local Authority or retailer for recycling advice. This appliance is marked according to the European directive 2012/19/EU on Waste Electrical and Electronic Equipment (WEEE).

By ensuring this product is disposed of correctly, you will help prevent potential negative consequences for the environment and human health, which could otherwise be caused by inappropriate waste handling of this product. The symbol on the product indicates that this product may not be treated as household waste. Instead it shall be handed over to the applicable collection point for the recycling of electrical and electronic equipment. Disposal must be carried out in accordance with local environmental regulations for waste disposal.

For more detailed information about treatment, recovery and recycling of this product, please contact your local council, your household waste disposal service or the retailer where you purchased the product.

CE DECLARATIONS OF CONFORMITY

This appliance has been manufactured to the strictest standards and complies with all applicable legislation, Low Voltage Directive (LVD), Electromagnetic Compatibility (EMC) and the Gas Appliance Regulation (GAR).

WARRANTY

Your new appliance is covered by warranty. The warranty card is enclosed - if it is missing, you must provide the following information to your retailer in order to receive a replacement: date of purchase, model and serial number. Registration can also be completed online by visiting www.caple.co.uk.

Ensure you keep your warranty card safe, you may need to show it to Caple Service together with proof of purchase.

If you fail to show your warranty card you will incur all repair charges. Spare parts are only available from Caple Service and spare parts authorised centres.

INSTRUCTIONS FOR THE USER

PRODUCT OVERVIEW

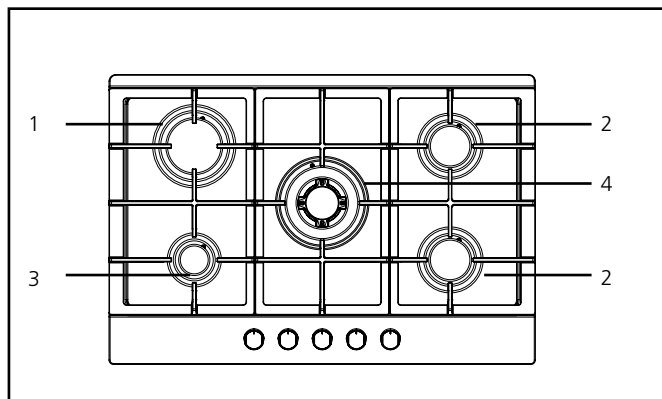

Burners

- 1 Rapid burner
- 2 Semi-rapid burner x2
- 3 Simmer burner
- 4 Triple ring burner

USING THE BURNERS

The flame symbols printed on the side of the control knobs indicate the correspondence between the knob and the flame size on the burner.

TO IGNITE A BURNER:

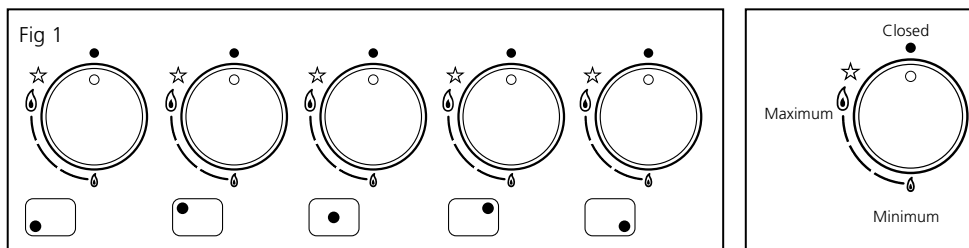

Turn the corresponding knob anti-clockwise up to the maximum position (large flame, fig.1) and press the knob. If you keep the control knob depressed, the automatic ignition for the burner will operate.

You should hold down the control knob for 15 seconds after the flame on the burner has lit. If after 15 seconds the burner has not lit, stop operating the device and open the compartment door and/or wait at least 1 minute before attempting a further ignition of the burner.

Please keep this instruction manual for future reference

After this 15-second interval, to regulate the flame you should continue turning the control knob anti-clockwise until the flame is at a suitable level. The operating position **MUST** be at a position between the maximum and minimum position.

To switch the burner off, turn the control knob fully clockwise to the gas off position. In case of power failure, the burners can be lit by carefully using a match.

USING THE BURNERS

In order to obtain the maximum yield without waste of gas, it is important that the diameter of the pan is suitable for the burner potential (see the following table) to avoid the flame reaching out past the pan (fig. 2).

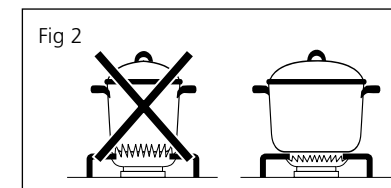

Burner	Pan Size min.	Pan Size max.
Auxiliary	120mm	180mm
Semi-rapid	180mm	220mm
Rapid	180mm	200mm
Triple ring	120mm	180mm

Use the maximum flame to quickly make liquids reach boiling temperature, and the reduced flame to heat food or maintain boiling. All of the operating positions must be chosen between the maximum and the minimum ones, never between the maximum position and 'off.'

WARNING:

- Do not use cookware that overlaps the edge of the burner.
- When you are no longer using the hob, always check that the knobs are in the off position.
- If the flame should blow out accidentally, the safety valve will automatically stop the gas supply after a few seconds. To restore operation, set the knob to the lighting point and press.
- While cooking with fat or oil, pay the utmost attention as these substances can catch fire when overheated.

Please keep this instruction manual for future reference

- Do not place unstable or deformed pans on the burner, so as to prevent them from overturning or overflowing.
- Make sure that pan handles are placed appropriately to avoid knocking the pans off from the hob.
- When the burner is started up, check that the flame is regular, and before taking pans away, always lower the flame or put it out.

CLEANING

Before any cleaning operation, disconnect the appliance from the electric grid. Don't use a steam cleaner for cleaning the hob.

It is advisable to clean the appliance when it is cold.

ENAMELLED PARTS

The enamelled parts must be washed with a sponge and soapy water or with a light detergent.

Do not use abrasive or corrosive products.

Do not leave substances, such as lemon, tomato juice, salt water, vinegar, coffee or milk on the enamelled surfaces for a long time.

STAINLESS STEEL PARTS

Stainless steel can be stained if it remains in contact with highly calcareous water or aggressive detergents for an extended period of time. The stainless steel parts should also be cleaned with soapy water and then dried with a soft cloth.

WARNING:

- After cleaning the burner, make sure that the lid is placed in the housing.
- The 2 reference cuts must be entered on the 2 references made on the flame retardant.
- The burner cap must be positioned steadily and flat.

BURNERS AND PAN SUPPORTS

These parts can be removed to make cleaning easier.

Remove the burner lids and Flame Spreaders by pulling them upwards and away from the top plate.

Soak them in hot water and a little detergent or washing up liquid.

After cleaning and washing them, wipe and dry them carefully.

Make sure that the flame holes are clean and completely dry.

Wipe the fixed parts of the Burner Cup with a damp cloth and dry afterwards.

Gently wipe the ignition device and flame supervision device with a well wrung-out cloth and wipe dry with a clean cloth.

Before placing the burners back on the top plate, make sure that the injector is not blocked.

Replace parts in the correct order after cleaning (fig. 3)

The locating pins must fit exactly into the notches.

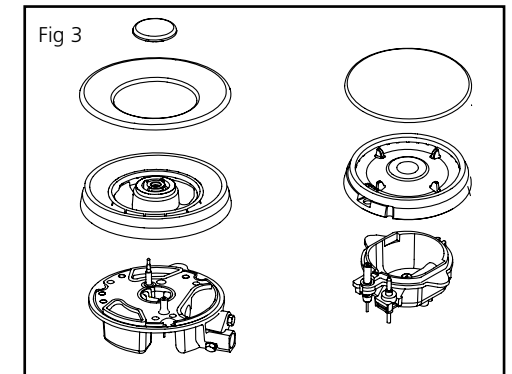

GAS TAPS

The possible lubrication of the taps must be carried out by specialised personnel only.

In case of hardening or malfunctions in the gas taps, contact Cable Service.

INSTRUCTIONS FOR THE INSTALLER

IMPORTANT NOTICE:

THE OPERATIONS INDICATED BELOW MUST BE FOLLOWED BY QUALIFIED PERSONNEL ONLY, IN CONFORMITY WITH THE REGULATIONS IN FORCE.

CAPLE REFUSES ALL RESPONSIBILITY FOR DAMAGES TO PEOPLE, ANIMALS OR OTHERS, RESULTING FROM THE FAILURE TO COMPLY WITH SUCH PROVISIONS.

INSTALLATION

Make a hole in the worktop of the dimensions indicated in figure 3 (at the end of this booklet) respecting a minimum distance of at least 50mm from the rear edge of the installed device and 100mm of the adjacent side walls.

This appliance is to be built into a kitchen unit or 600mm worktop depth, providing the following minimum distances are allowed

- The edges of the hob must be a minimum distance of 60mm from a side or rear wall.
- 700mm between the highest point of the hob surface (including the burners), and the extractor or kitchen cabinet above.
- 400mm between the hob surfaces, providing that the underside of the horizontal surface is in line with the outer edge of the hob. If the underside of the horizontal surface is lower than 400mm, then it must be at least 50mm away from the outer edges of the hob.
- 50mm clearance around the appliance and between the hob surface and any combustible materials.
- You must have a gap of at least 25mm and at most 74mm between the underneath of the appliance and any surface that is below it.
- An oven must have forced ventilation to install a hob above it.
- Check the dimensions of the oven in the installation manual.
- The cut out must follow the template.

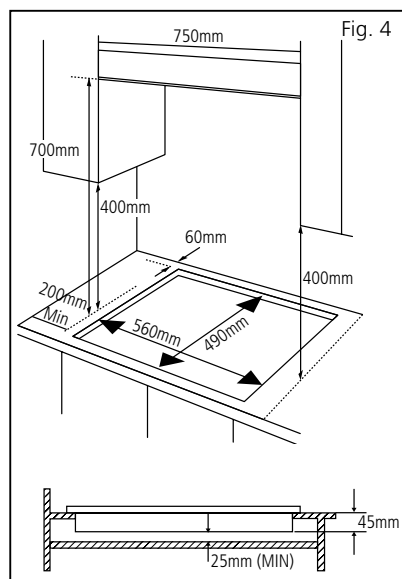

If the hob is going to be installed on top of an oven, precautions must be taken to guarantee an installation in accordance with current accident prevention standards. Pay particular attention to the position of the electric cable and gas pipe: they must not touch any hot parts of the oven.

Moreover, if the hob is going to be installed on top of a built in oven without forced cooling ventilation, proper air vents must be installed to guarantee an adequate ventilation, with the lower air entering with a cross section of at least 200cm², and the higher air exiting with a cross section of at least 60cm².

FASTENING THE HOB

Every hob is equipped with a special seal (fig 5). A set of fixing clips are also supplied for securing the hob to the worktop (fig 6).

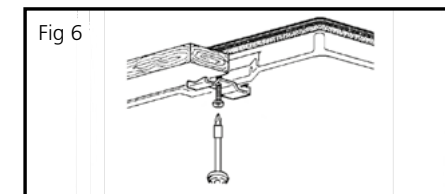
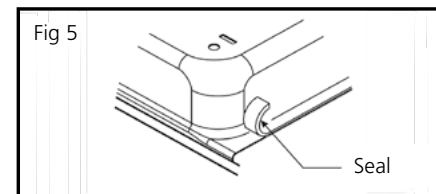

INSTALLATION ROOM

This appliance is not provided with a device for exhausting the products of combustion. Regarding room ventilation rules where appliance is installed make reference to the legislation, in conformity with the local regulations.

FOR THE U.K. ONLY

The room containing this hotplate should have an air supply in accordance with BS 5440: Part 2: 1989.

- All rooms require an open-able window, or equivalent and some rooms will require a permanent vent as well.
- For room volumes up to 5m³, an air vent of 100cm² is required.
- For room volumes between 5m³ and 10m³, an air vent of 50cm² is required.
- If the room is greater than 5m³ and has a door that opens directly to the outside, then no air vent is required.

If there are other fuel burning appliances in the same room BS 5440: Part 2:1989 should be consulted to determine the air vent requirements.

GAS CONNECTION

Make sure that the appliance is adjusted for the gas type available (see the label under the appliance). Follow the instructions indicated in the chapter “Gas adjustments” for the possible adaptation to different gases.

The appliance must be connected to the gas system by means of stiff metal pipes or flexible steel pipes having continuous walls, in compliance with the regulations in force. Some models are equipped with both cylindrical A and conical B connectors for gas supply (fig. 7 & 8).

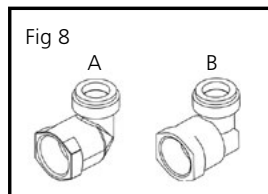
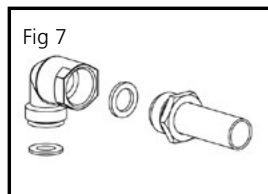

Please select the type which is correct for the supply concerned. The connection must not stress the gas ramp. Once the installation is over, check the connection seal with a soapy solution.

ELECTRIC CONNECTION

The connection to the electric grid must be carried out by qualified personnel and in conformity with the regulations in force. The voltage of the electric system must correspond to the value indicated in the label under the appliance. Make sure that the electric system is provided with an effective ground connection in compliance with the regulations and provisions of the law.

GROUNDING IS COMPULSORY

This device must be at a suitable opening distance from the contacts in order to allow the entire disconnection in case of over voltage category III, in accordance with installation rules.

GAS ADJUSTMENTS

- Take precautions on the operations and adjustments to be carried out when converting from one gas to another.
- All work must be carried out by a qualified technician
- Before you begin, turn off the gas and electricity supply to the appliance.

CHANGE THE INJECTOR OF THE BURNERS

- Remove the pan support, Burner Lid and Flame Spreader.
- Unscrew the injector using a 7mm box spanner and replace it with the stipulated injector for new gas supply.
- Carefully reassemble all the components.
- After injectors are replaced, it is advisable to strongly tighten the injector in place.

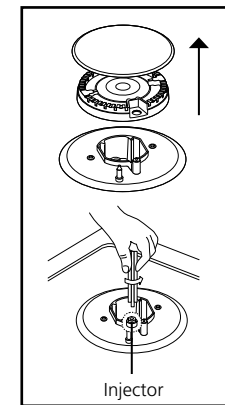

ADJUSTMENT OF MINIMUM LEVEL OF THE FLAME

- Turn the taps down to minimum.
- Remove the knob from the tap and place a small bladed screwdriver in the centre of the tap shaft.
- The correct adjustment is obtained when the flame has a length of about 3 - 4 mm.
- For butane propane gas, the adjusting screw must be tightly screwed in.
- Refit the control knob.
- Make sure that the flame does not go out by quickly turning from maximum flow to minimum flow. If it does then remove the control knob and make further adjustments to the gas flow, testing it again once the adjustment has been made.
- Repeat this process for each one of the gas taps.

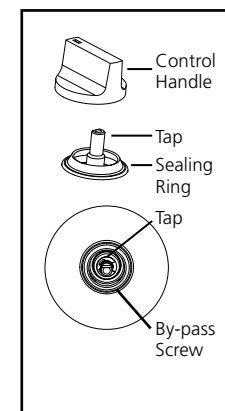

WARNING:

- Do not dismantle the tap shaft: in the event of a malfunction, change the whole tap.
- Before placing the burners back on the top place, make sure that the injector is not blocked.
- A full operational test and a test for possible leakages must be carried out after gas conversions (such as soap water or gas detector).
- After completing conversion, a qualified technician or installer has to mark "V" on the right gas category to match with the setting on the rating plate. Remove the previous setting "V" mark.

MAINTENANCE

Replacing the power supply cable.

If the power supply cable should be replaced, it is necessary to use a cable with a section of 3x0.75mm², type H05VV-F or H05RR-F, complying with the regulations in force. The connection to the terminal board must be effected as shown in fig 9:

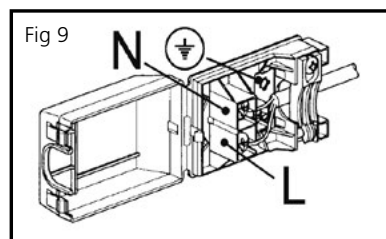

- Fig 9
- Brown cable (Live)
 - Blue cable (Neutral)
 - Green-yellow cable (Earth)

GAS SPECIFICATION

Model No.	Gas type & pressure	Electrical power	Heat input and orifice size marked (mm)					Total Heat input
			Triple-Crow burner	Rapid burner	Semi-rapid	Semi-rapid	Auxiliary-rapid	
C767G		110-240V~ 50/60Hz	3.3kW (241g/h)	3.0kW (219g/h)	1.75kW (127g/h)	1.75kW (127g/h)	1.0kW (73g/h)	10.8kW (787g/h)
	G31 37mbar	110-240V~ 50/60Hz	0.93	0.85	0.65	0.65	0.50	–
	G30 29mbar		0.93	0.85	0.65	0.65	0.50	–
	G30 20mbar		1.28	1.30	0.97	0.97	0.72	–
G25 25mbar	1.40		1.22	0.95	0.95	0.72	–	

The performance of each individual burner is calculated according to standard EN 30-2-1 (2015). The total efficiency of the hob is calculated according to the EU Regulation 66/2014 Par. 2.2. The efficiency is calculated only for the burners with a nominal capacity exceeding 1,16 KW (EN 30-2-1 (2015)).

ENERGY SAVING TIPS:

- Use pans that have a flat base.
- Use pans with proper size.
- Use pans with a lid to minimise the amount of liquid or fat. When liquid starts boiling, reduce the setting.

DIMENSIONS

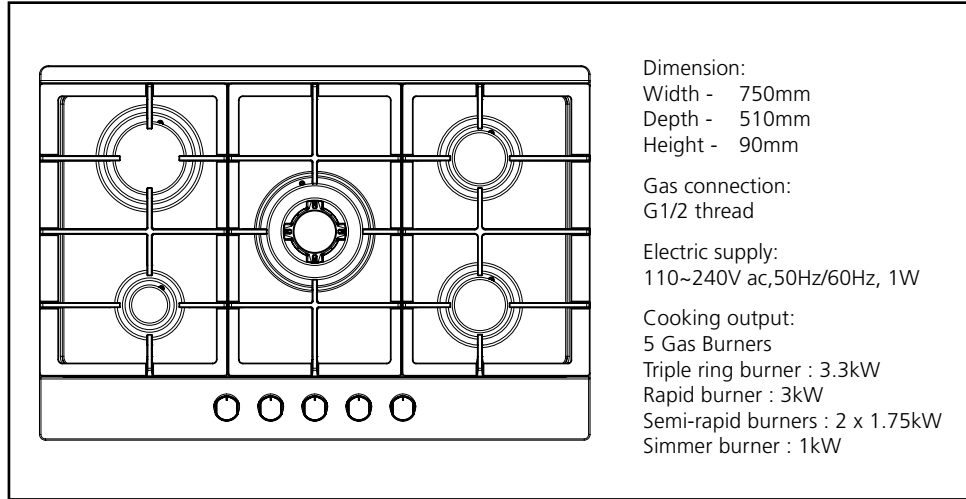

TROUBLE SHOOTING

Problem	Probable cause	Solution
Not ignited.	No Spark.	Check the electricity supply.
	The burner lid is badly assembled.	Assemble the lid correctly.
	The gas supply is closed.	Open the gas supply completely.
Badly ignited.	The gas supply is not completely open.	Open the gas supply completely.
	The burner lid is badly assembled.	Assemble the lid correctly.
	The ignition plug is contaminated with alien substance.	Wipe alien substance with a dry cloth.
	The burners are wet.	Dry the burners lids carefully.
Noise made when combusted and ignited.	The holes in the flame spreader are clogged.	Clean the flame spreader.
	The burner lid is badly assembled.	Assemble the burner lid correctly.
Flame goes out when in use.	The flame supervision device is contaminated with an alien substance.	Clean the flame supervision device.
	Product being cooked has boiled over and extinguished the flame.	Turn off burner knob. Wait one minute and reignite zone.
	A strong draught may have blown the flame out.	Please turn off zone and check cooking area for draught such as open windows. Wait 1 minute and reignite zone.
Yellow Flame.	The holes in the flame spreader are clogged.	Clean the flame spreader.
	Different gas is used.	Check the gas used.
Unstable Flame.	The burner lid is badly assembled.	Assemble the burner lid correctly.
Gas Smell.	Gas leakage.	Stop using the product and close the main supply valve. Open the window to ventilate. Contact Caple Service and your gas supplier.

GUARANTEE

Caple undertake that if within 2 years from the date of purchase, this appliance or any part thereof that is proved to be defective by reason only of faulty workmanship or materials, will at our option, repair or replace the same free of charge (for labour or materials) on condition that:

- Documentation must be provided before a guarantee repair commences to confirm that the extractor is within the guarantee period.
- The appliance has been correctly installed and used only on the electrical supply stated on the rating plate.
- The appliance has been used for normal domestic purposes only, and in accordance with the operating and maintenance instructions.
- The appliance has not been serviced, maintained, repaired, taken apart or tampered with by any person not authorised by us.
- All service work under this guarantee must be undertaken by Caple Service Centre.
- Any appliance or defective part replaced shall become the property of this company.
- If a service call is made and it is found that the installation has not been carried out correctly or customer misuse/abuse is involved, the cost of the service call has to be paid for by the user before any service work is carried out.

EXCLUSIONS

THIS GUARANTEE DOES NOT COVER:

- Damage or calls resulting from transportation, improper use or neglect, the replacement of any light bulbs or removable parts of glass or plastic.
- Costs incurred for calls to put right appliances improperly installed or calls to appliances outside the United Kingdom.
- Appliances found to be in use within a commercial environment, plus those which are the subject of rental agreements.
- This guarantee is in addition to and does not affect your statutory and legal rights.

NOTES:

Caple Service
Fourth Way
Avonmouth
Bristol
BS11 8DW

t: 0117 938 7420
e: service@caple.co.uk
www.caple.co.uk

Please keep this instruction manual for future reference