



DI626

Caple Integrated Dishwasher

Technical information



DI626

Caple Integrated Dishwasher

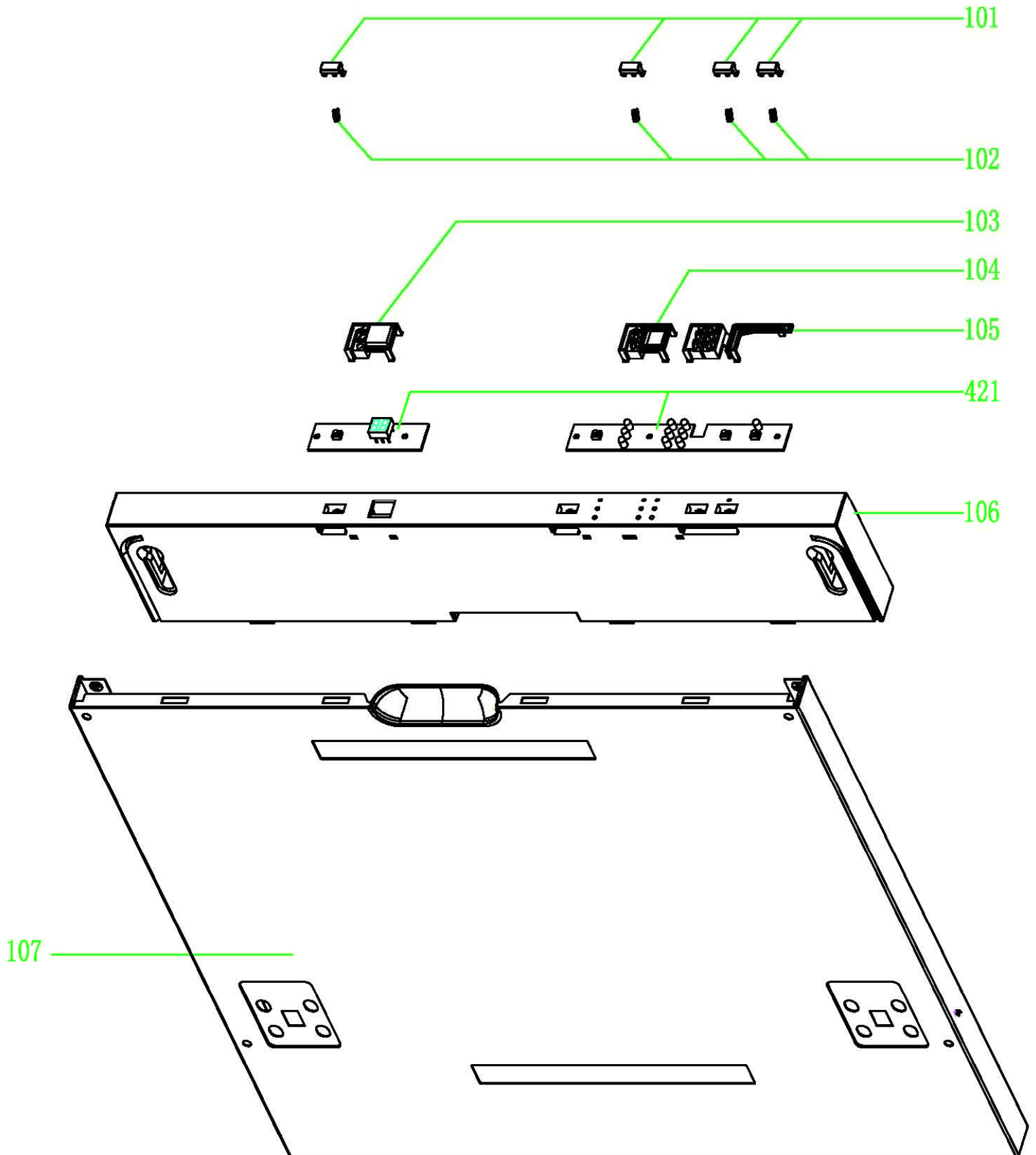



DI626

Caple Integrated Dishwasher

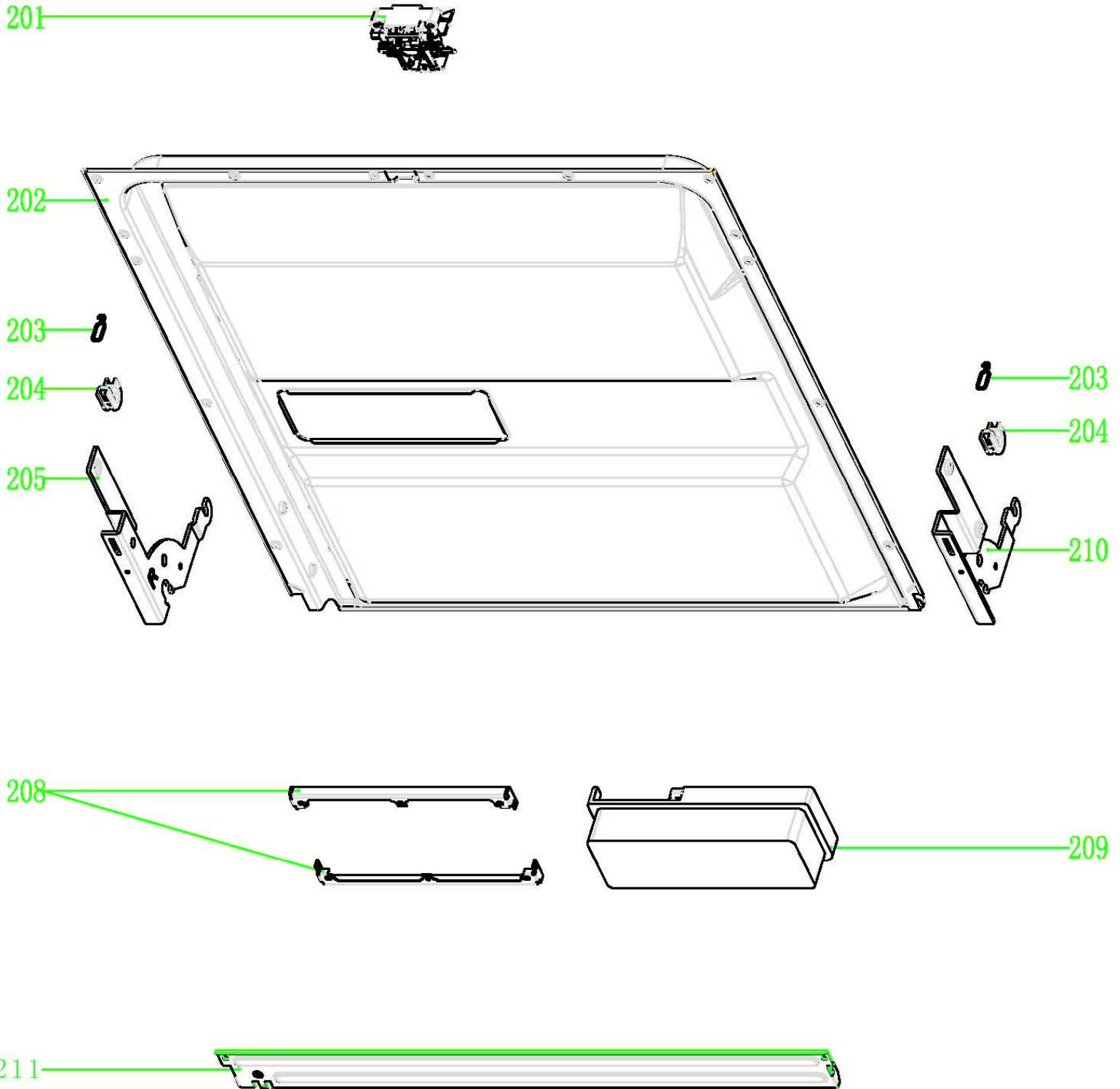



DI626

Caple Integrated Dishwasher

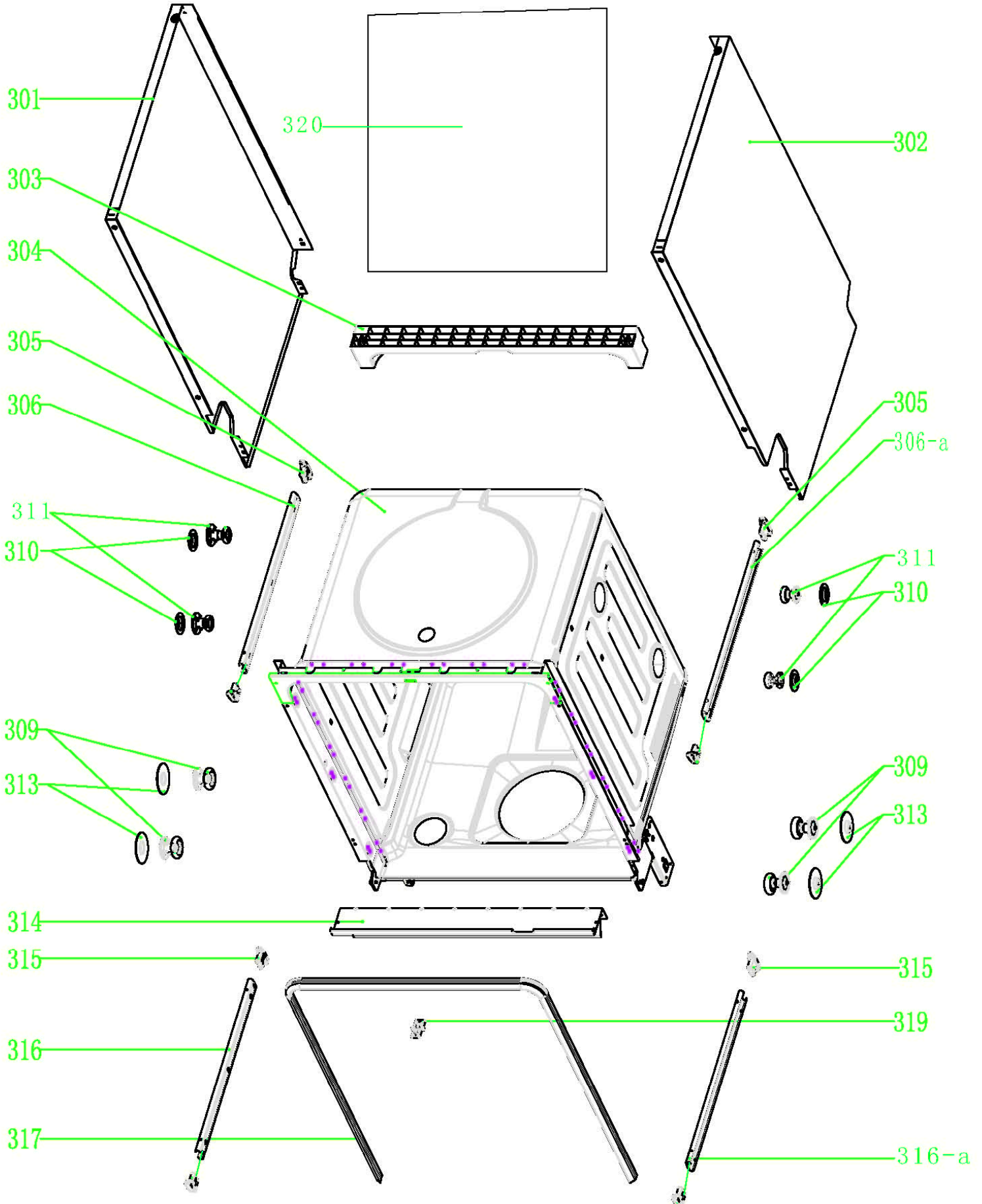

DI626

Caple Integrated Dishwasher

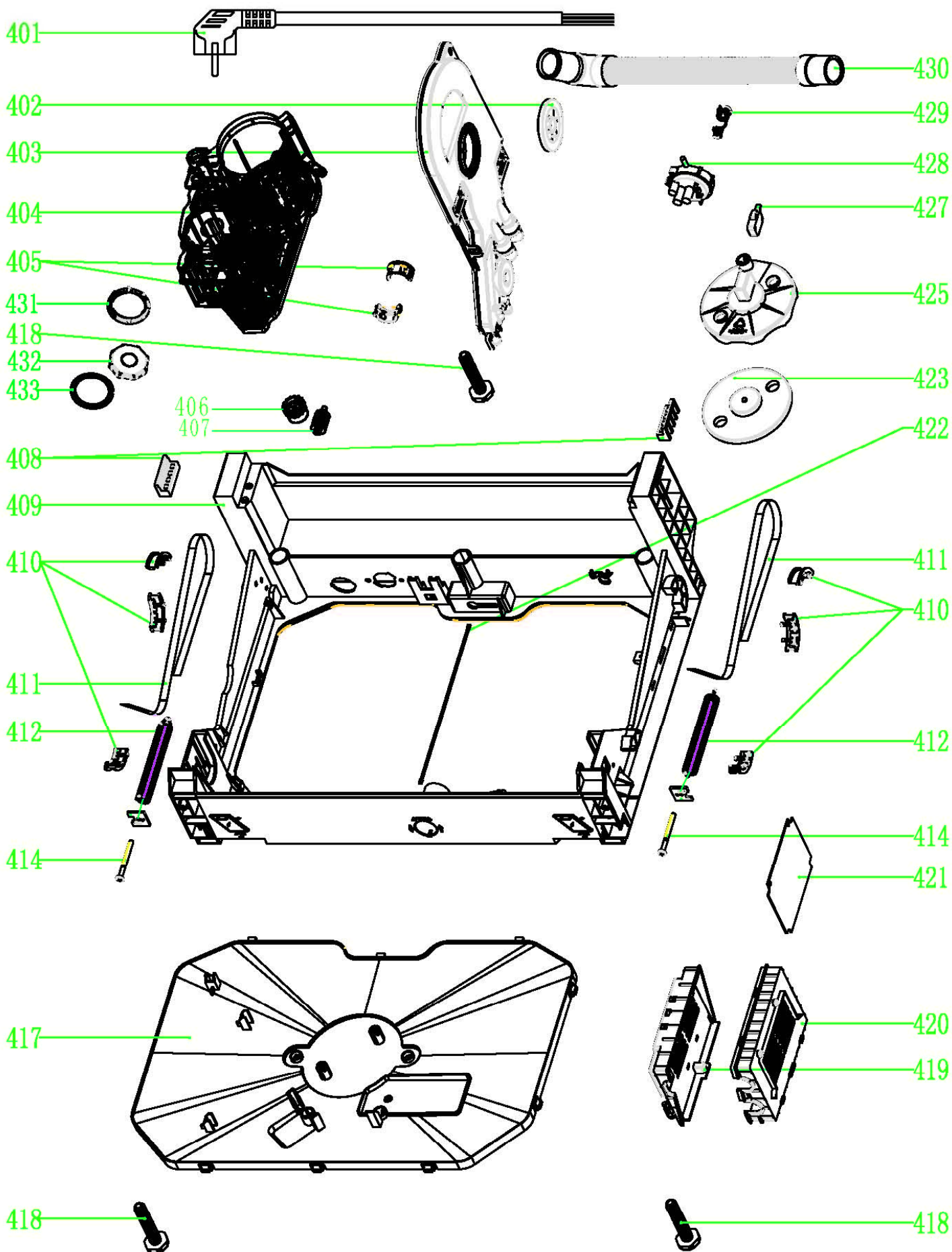

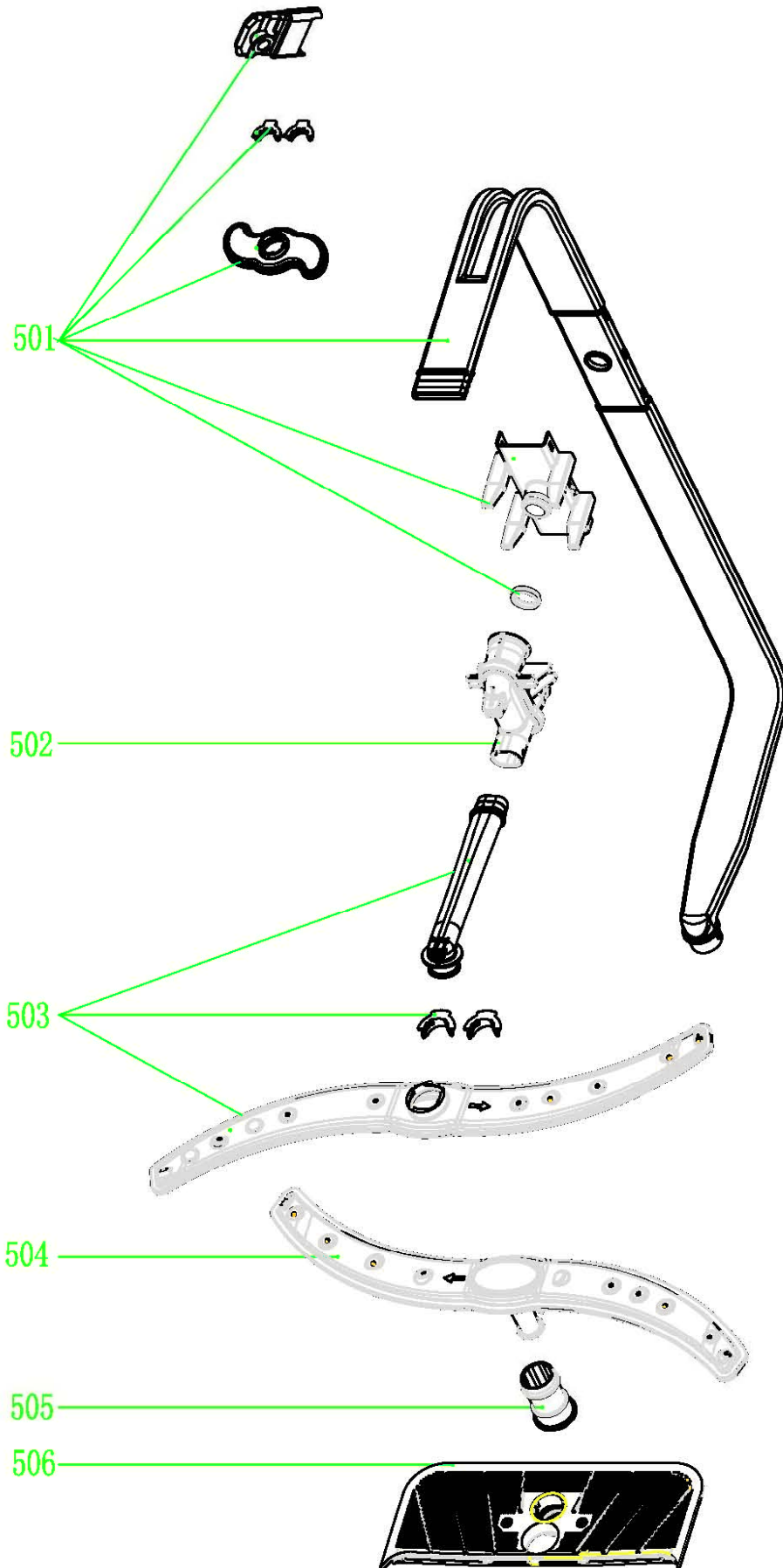

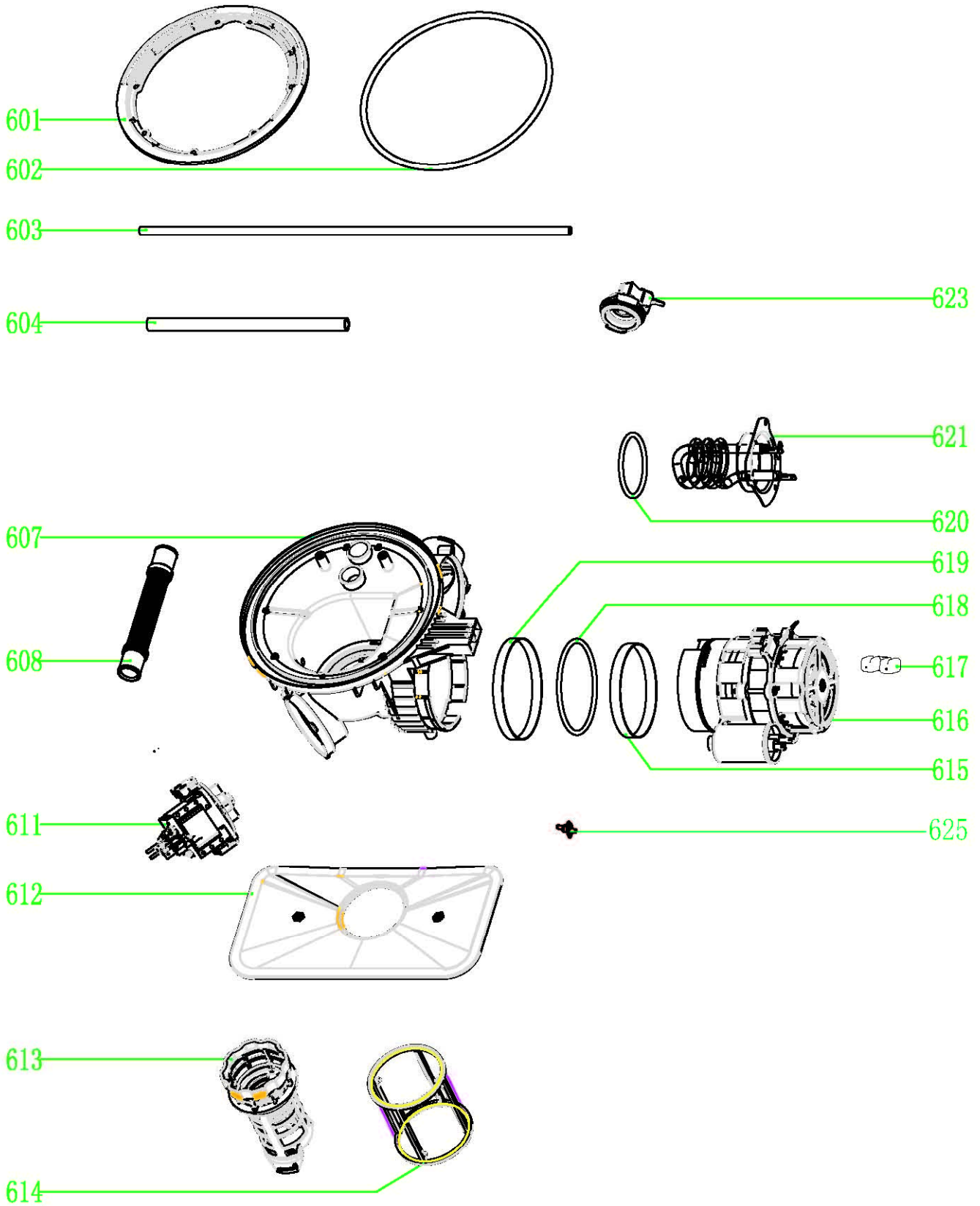



DI626

Caple Integrated Dishwasher

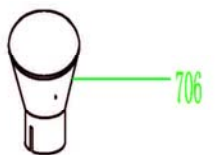
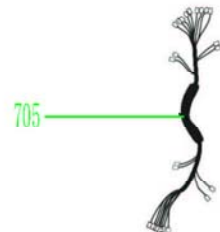
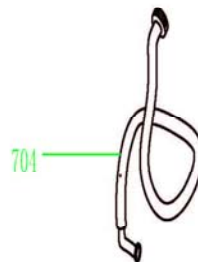
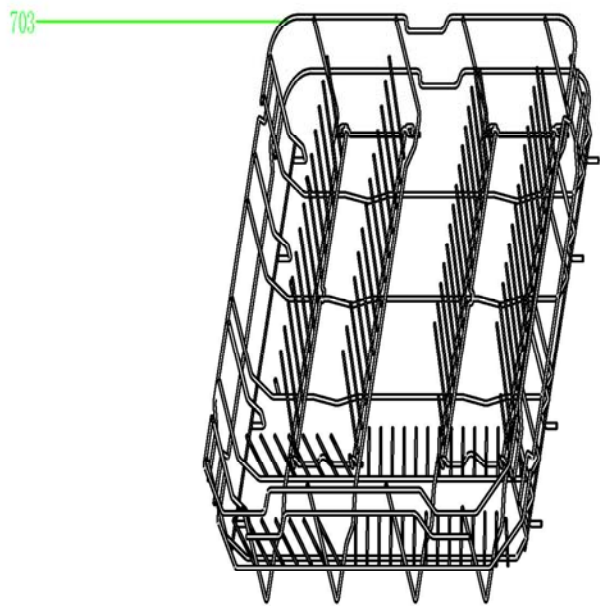
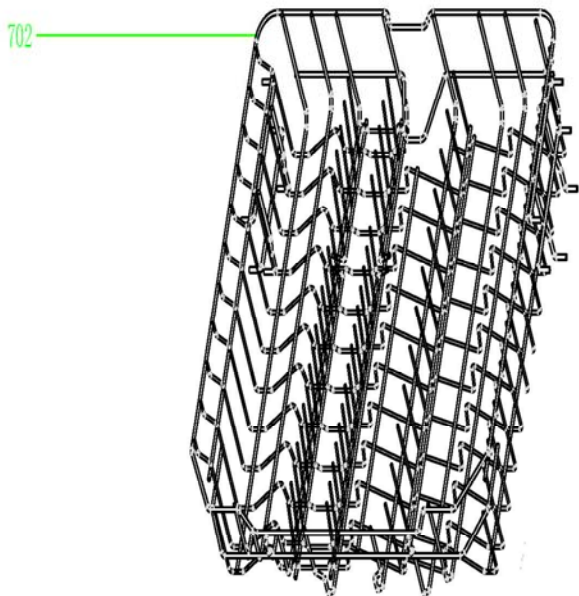
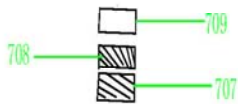
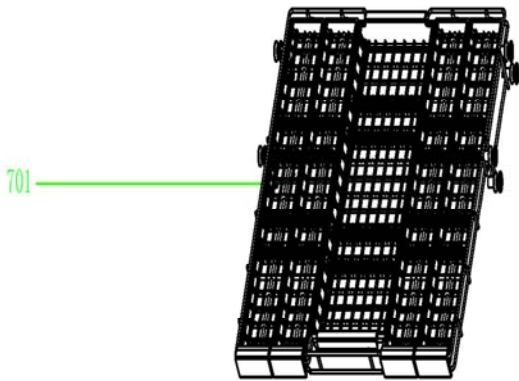



DI626 - Caple 60cm Fully Integrated Dishwasher

Item	Part Code	Description	Qty
101	673000801755	Button	4
102	672000100012	Button Spring	4
103	673002401005	Light Cover 2	1
104	673002401004	Light Cover 3	1
105	673002401003	Light Cover 1	1
106	673000405450	Control Panel	1
107	672001804043	OUTER DOOR	1
201	674010030017	DOOR SWICTH ASSEMBLY	1
202	672002200324	INNER DOOR	1
203	672002300037	FRICITION STRIP HOOKING	2
204	672002300049	FRICITION STRIP HOOKING clip	2
205	672001400059	LEFT HINGE	1
208	672001700002	DISPENSER BRACKET	2
209	674000800032	DISPENSER	1
210	672001400058	RIGHT HINGE	1
211	672001200061	HINGE join board	1
301	672001602006	LEFT SIDE PANEL	1
302	672001602007	RIGHT SIDE PANEL	1
303	673003100010	UPPER back support	1
305	673001300551	Cutlery shelf guider link stopper(back)	2
306	672001700023	Cutlery shelf guider (Left)	1
309	672001700039	basket guider supporter	4
310	673001300552	Cutlery shelf guider supporting holder	4
311	673001400295	Cutlery shelf guider assembly	4
313	673001300555	basket guider supporting holder	4
314	672002300035	anti-noise borad	1
315	673001300639	UPPER BASKET guider link stopper(back)	2
316	672001700025	UPPER BASKET guider (Left)	1
317	673001700124	door seal GASKET	1
319	672001400068	DOOR LOCK HOOK	1
320	673000102014	Back cover board	1
401	674000000186	Power cord	1
402	673001600058	AIR BREAKER NUT	1
403	673002700601	AIR BREAKER ASSEMBLY	1
404	674000700032	SOFTENER ASSEMBLY	1
405	673001300557	DRAIN pipe CLAMPING	4
406	673001300583	Bevel wheel	1
407	673001400212	Worm	1
408	673001300556	tub Support	2
409	673000103020	Base ASSEMBLY	1
410	673001000052	FRICITION STRIP GUIDING	6
411	672002300036	FRICITION STRIP	2
412	672000190029	DOOR SPRING	2
414	672001100016	adjust screw OF DOOR SPRING	2



DI626 - Caple 60cm Fully Integrated Dishwasher

Item	Part Code	Description	Qty
417	673000101027	base cover	1
418	673001400210	foot	3
419	673002400216	pcb seat cover	1
420	673002400128	pcb seat	1
421	674001001064	pcb	1
422	673001400211	Adjust pole	1
423	673001490013	FLOAT	1
425	673001400197	overflow switch seat	1
427	674010030006	overflow switch	1
428	674000300072	PRESSURE SWITCH	1
429	673001400083	power supply loom clamping	1
430	673000900354	DRAIN pipe	1
431	673001600068	SOFTENER nut	1
432	673002800161	SOFTENER cover	1
433	673001500106	SOFTENER rubber	1
501	673000900364	INNER PIPE ASSEMBLY	1
502	673001900030	water DISPENSER ASSEMBLY	1
503	673001900027	MIDDLE SPAYER PIPE ASSEMBLY	1
504	673000330000	LOWER SPRAYER	1
505	673001300548	LOWER SPRAYER seat	1
506	673002500112	PLASTIC FILTER	1
601	673001600057	SUMP NUT	1
602	673001500104	SUMP GASKET	1
603	673000900160	PVC pipe	1
604	673000900350	softener outlet pipe	1
607	673000701025	SUMP ASSEMBLY	1
608	673000900367	INNER DRAIN pipe	1
611	674000600154	Drainage pump	1
612	673002500124	main filter	1
613	673001300644	filter handle	1
614	673002500111	CYLINDR FILTER	1
615	673001500069	PUMP VIBRATION-PROOF PAD	1
616	674005600087	WASH PUMP ASSEMBLY	1
617	672002300038	motor holder	1
618	673001500111	PUMP GASKET	1
619	672000700031	940 CLAMPING	1
620	673001500115	HEATING ELEMENTS GASKET	1
621	674001100053	HEATING ELEMENTS ASSEMBLY	1
623	674010020008	WATER PRESSURE SWITCH ASSEMBLY	1
625	674000900053	Sensing device	1
701	673003200025	Cutlery shelf ASSEMBLY	1
702	672000810017	UPPER BASKET ASSEMBLY	1
703	672000820000	LOWER BASKET ASSEMBLY	1
704	674000200041	Inlet hose assembly	1
705	674002000034	Wiring harness	1
706	673002200165	Salt filler	1
707	673000101047	basket Handle lid (front)	1
708	673000101048	basket Handle lid (back)	1



DI626 - Caple 60cm Fully Integrated Dishwasher

Item	Part Code	Description	Qty
709	672000301720	BASKET HANDLE adhibit piece	1
306-a	672001700024	Cutlery shelf guider (Right)	1
316-a	672001700026	UPPER BASKET guider(Right)	1
	17476000001113	Internal LED	

Technical Service Manual



Dishwasher

Contents

Specification	2
Function Description	3-4
Water circuit	3-4
Theory of parts	5-23
Location	5
PCB	6-7
Inlet valve	8-10
Drain pump	11-12
Heater	13-14
Washing pump	15-16
Pressure switch	17
NTC	18-19
Flowmeter	20-21
Safety Hose	22-23
Test program	24-28
Procedure	25
Error code	26-28
Inspection	29-32
Troubleshooting	33-37

SAFETY NOTICE

This documentation is only intended for qualified technicians who are aware of the respective safety regulations.

Models: WQP12-7313B

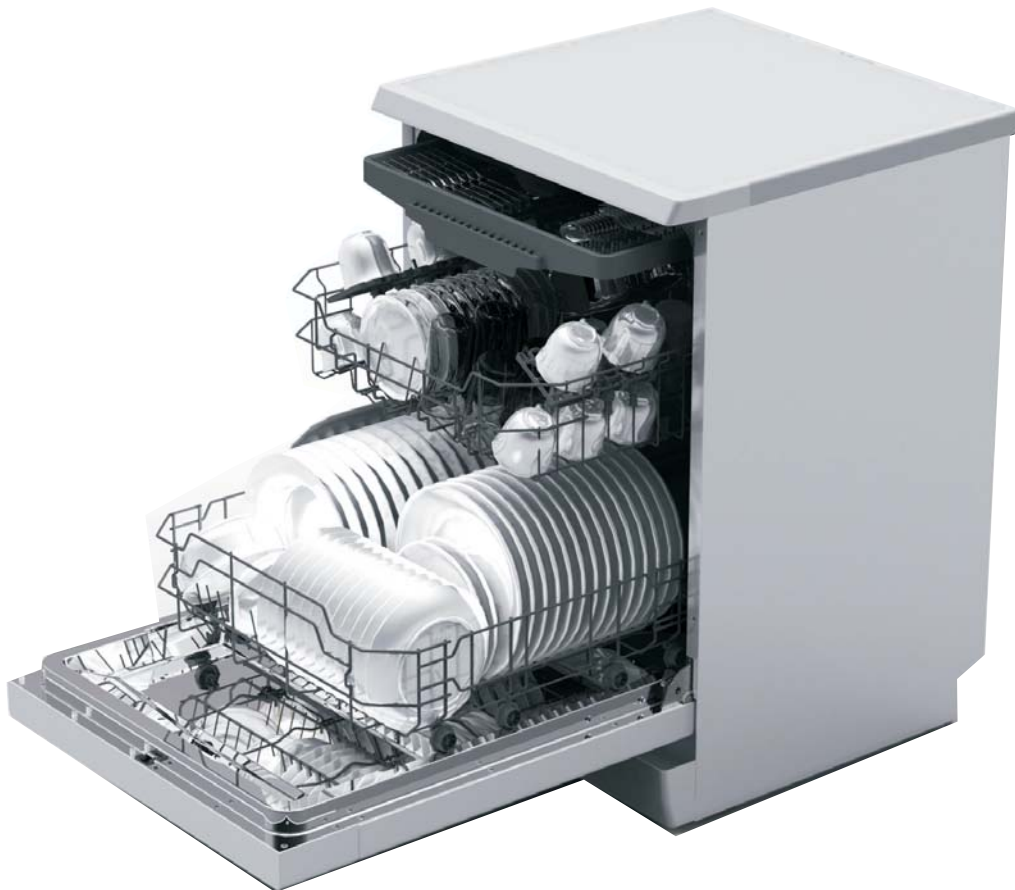

Electrical supply	220-240V, 50Hz
Supply water pressure	0.04MPa-1.0MPa
Supply water temperature	below 60°C

For the basic operation instructions, please refer to the instruction manual attached with each unit.

Water circuit scheme

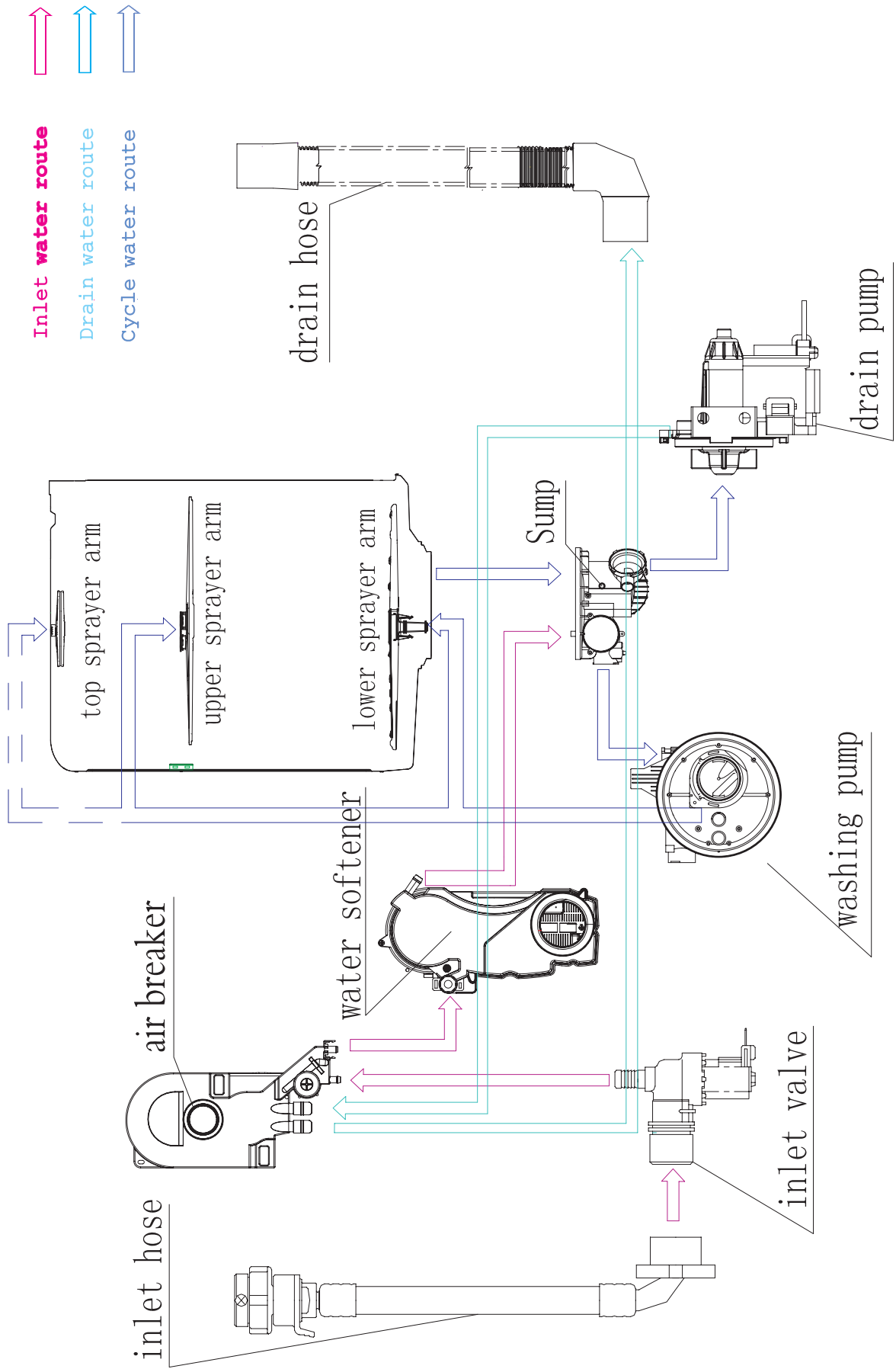

Process of water inlet (indicated by magenta route)

In this process, regeneration water route is cut off, main water route is open. The water in the main water route is softened when pass through the softener, and then enter in the tub. During this phase, some of inlet water will be stored in the air breaker to be regenerating water.

Process of cycle washing (indicated by blue route)

Cycle washing action is driven by washing pump motor. Water can obtain the power during it passing through the working washing pump, then be pumped into spray arm, pass from spray arm nozzles, over the dishes, into sump ,where connect to washing pump, and to get in the next water cycle.

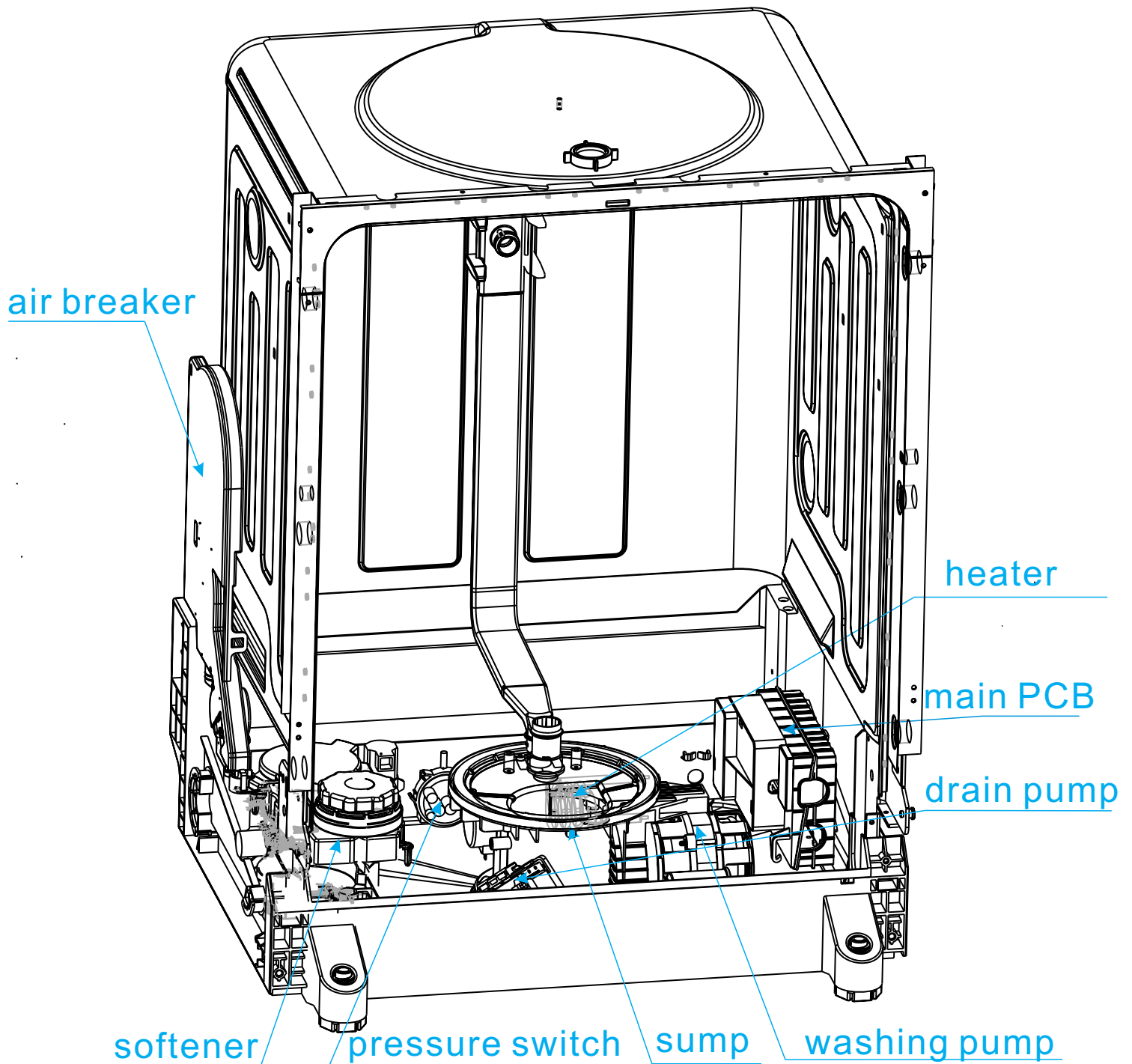

Please Note: Explode view and part list of each model have some different visions. So please refer to the newest vision Midea sent you

PCB

Printed Circuit Board is the control center of dishwasher, which receive and process signal from components, send order to components and deal with the feedback information, etc.

Access PCB

Removing the protecting box.

The PCB can be removed from the protecting box in the bottom of machine.

1. Disconnect power supply;
2. Take out cutlery basket, basket and filter system;
3. Open the cover of bottom board.
4. Remove the screws for fixing protecting box and open the protecting box cap.

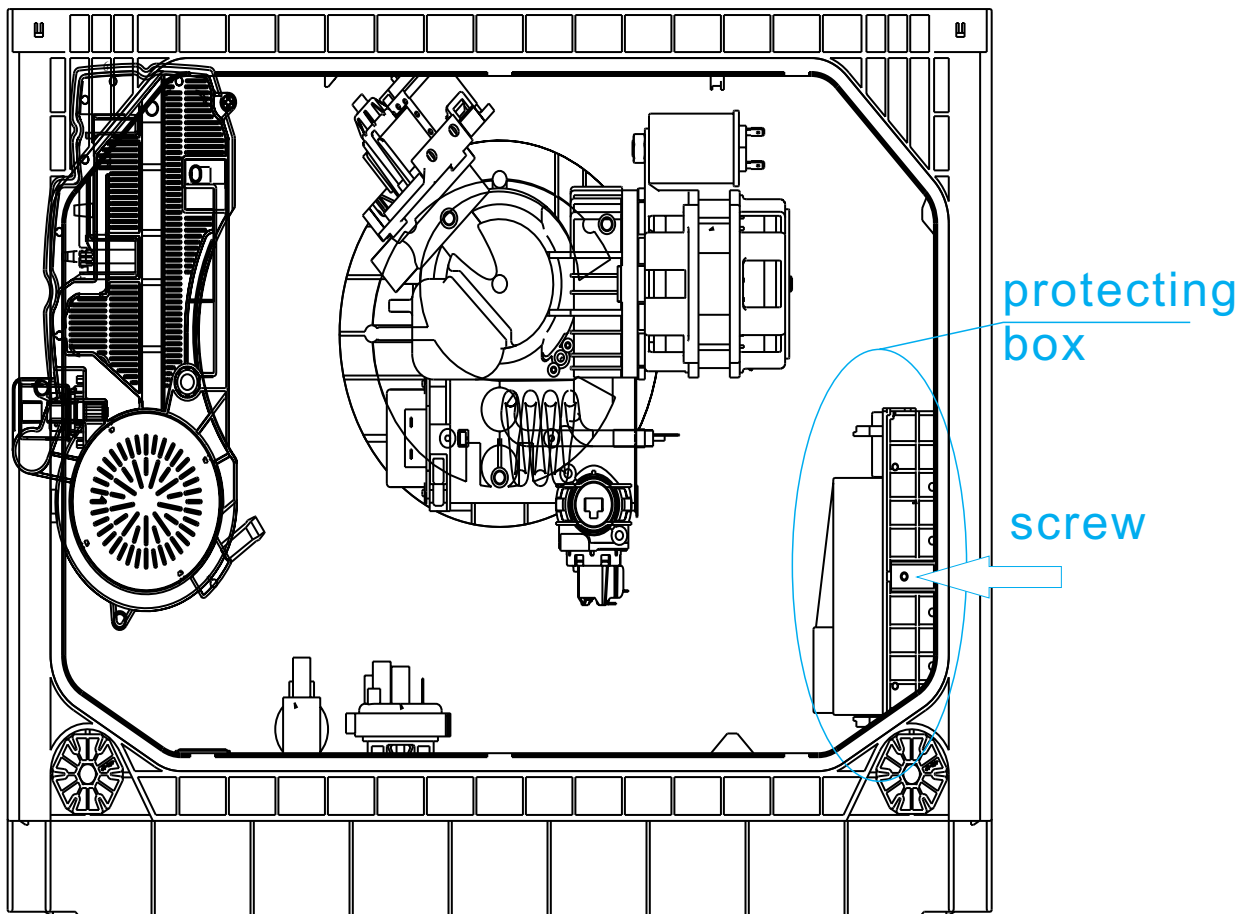

Bottom view

5. Disconnect the connector form PCB.
6. Remove the screws securing the PCB to control panel.
7. Remove the PCB.
8. Reverse the above procedure to install.

View of PCB

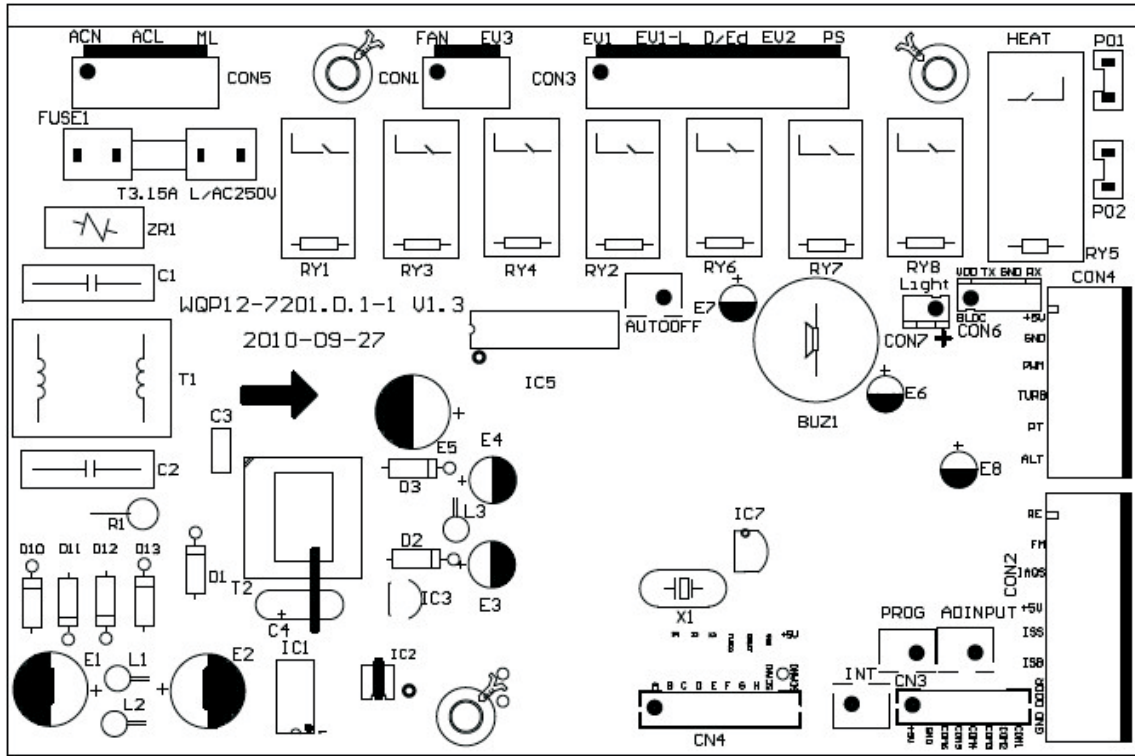

Note: This map is applies to 7201 model.

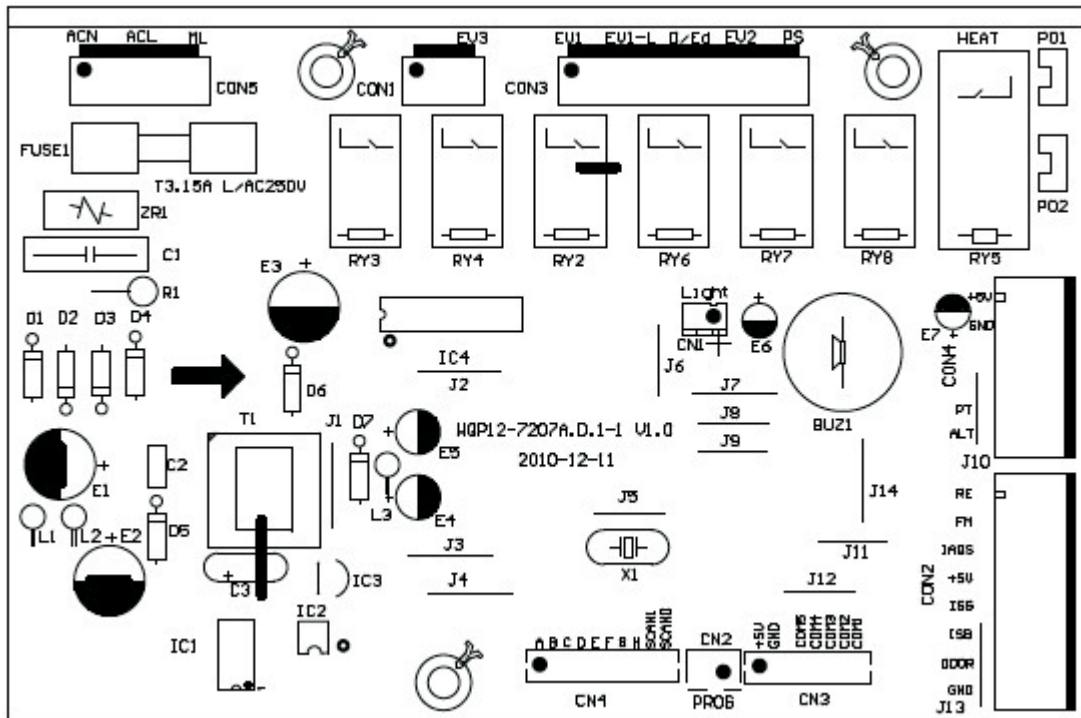

Note: This map is applies to 7207A model.

Description

Mark	Function
HEAT	Output for Heating Element
ACL	Input of line
ACN	Input of neutral
EV-L	Input of inlet valve
RE	Thermister
ML	Washing Pump
PS	Drain Pump
D/ED	Dispenser
EV1	Inlet valve
EV2	Softener
EV3	Halfload Valve
ISS	Salt detect
ISB	Rinse detect
IAQS	Overflow detect
FM	Flowmeter
FAN	Fan

There is small pole's location difference between different models.
But the marks on PCB have the same meaning described on the left side.

Location of inlet valve

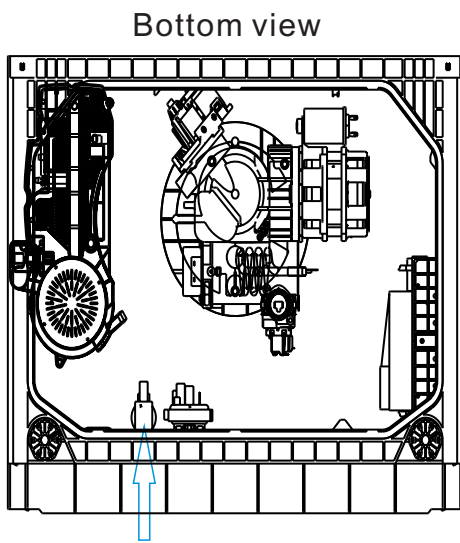

Appearance

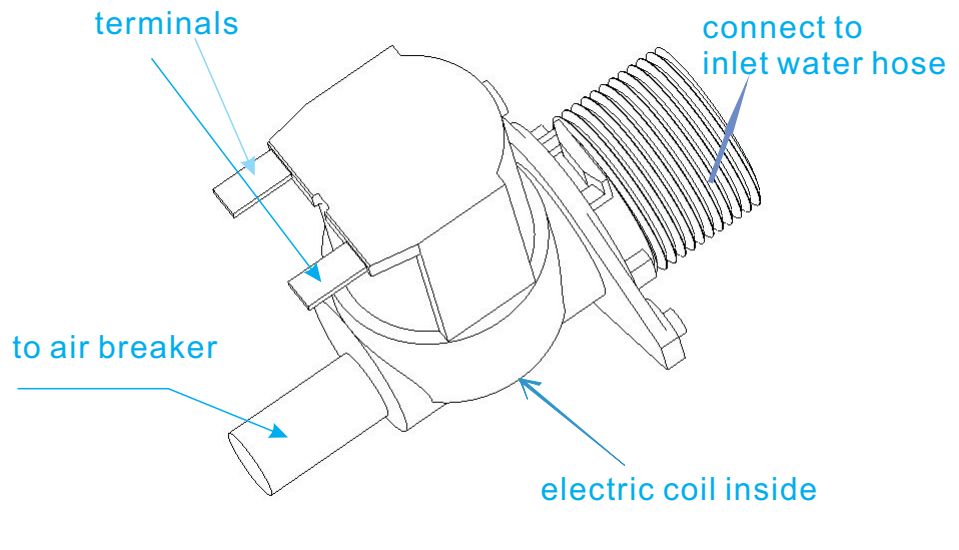

The work principle

The inlet valve is electromagnetic valve that decide whether water enter or not. Valves are normally closed. Each time the appliance requires water, the controller will convey an electric signal to the coils to open the valves.

The inlet valve consist of electric coil, valve body, valve pole, filter etc.

In a word, the electromagnetic valve can act to allow water enter into machine, when it receive the order given by controller.

The defeat point

1. The valve coil is broken, so the valve can't open. It will cause the E1 error.
2. The filter is jammed, so water can't enter. It will cause the E1 error.
3. The connector is loose, so the valve can't open. It will cause the E1 error.
4. The valve pole is rusted or locked by dreg, so the valve can't open or close. It will cause the E1 or E4 error.

Technical data

Nominal voltage	220-240VAC
Frequency	50/60Hz
Resistance	Approx:3.4 - 4.4kΩ
Work duty	100%ED T25 3min/5min T60
Flux	2.5L/min 15%
Power	5W
Work Pressure	0.04 - 1MPa

Access inlet valve

1. Disconnect power.
2. Remove the water inlet hose. (Note : Be careful of remain water drop.)
3. Remove the cover of the bottom board.

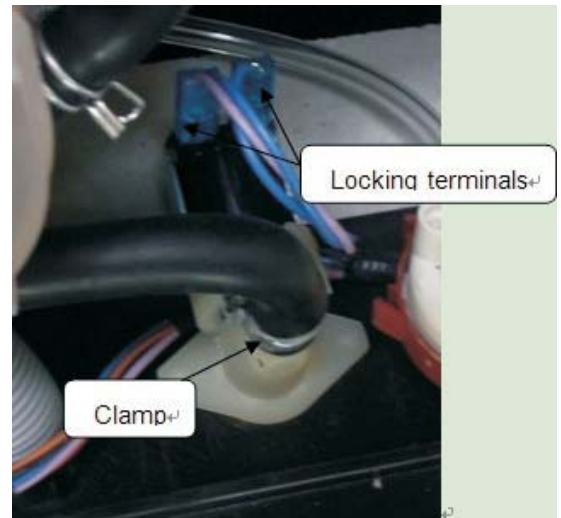
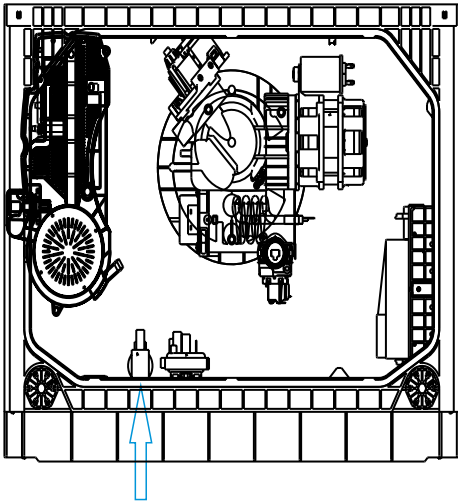

4. Disconnect the 2 terminal lugs from the inlet valve.
5. Pull out the valve a little then contrarotate it to take it off.
6. Remove the clamp and disconnect the inlet hose (to air breaker) from the water valve.
7. Reverse above procedures to install.

Inspect inlet valve

Check electric part

1. Open the protecting box and take out the PCB;
2. With the door closed, unplug the CON3 and ACN wires , then use the multi-meter Ω shelf to measure resistance between the blue wire (EV1) and the blue wire(ACN), the normal resistance is about $3.4K\Omega$ to $4.4K\Omega$.
3. If the measured resistance is not correct, it means the valve coil is broken or the connector is loose. In this case, we should check the connection first. If the problem hasn't been solved by re-connection, we should replace the valve..
4. If the resistance is OK, we need to inspect the valve body.

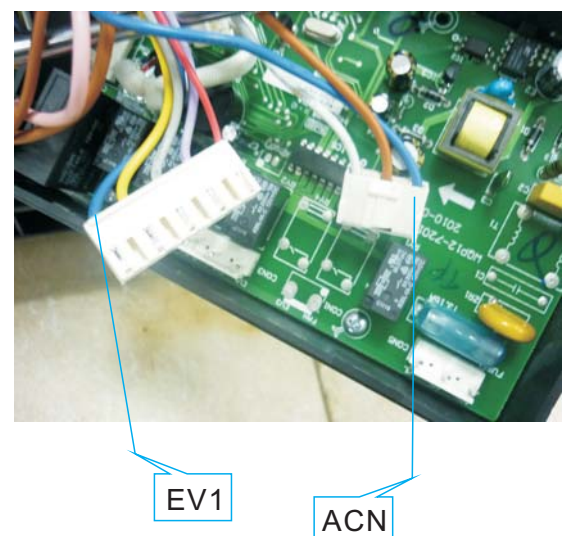

Check machine part

1. If the electric part is OK, we need to check the machine part.
2. Check the valve filter. if the valve filter is blocked, we need clear the residues.
3. If the valve filter is clear and the valve can't inlet water, check whether valve can act or not. If it isn't , we need replace the valve.
4. If the water is continue entering, we need replace the valve.

Location of Drain Pump

Bottom view

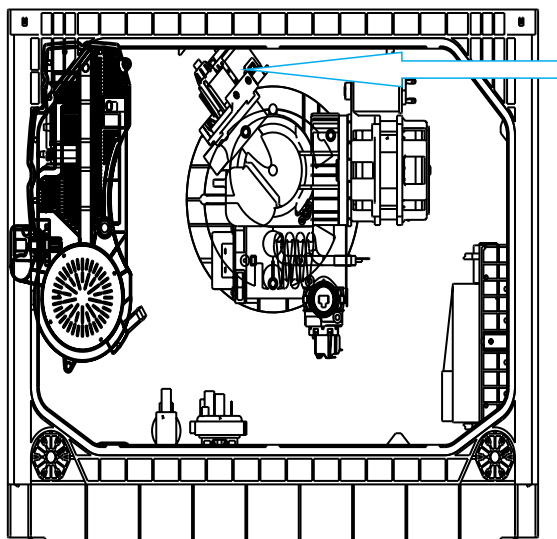

The work principle

Drain pump integrated into sump

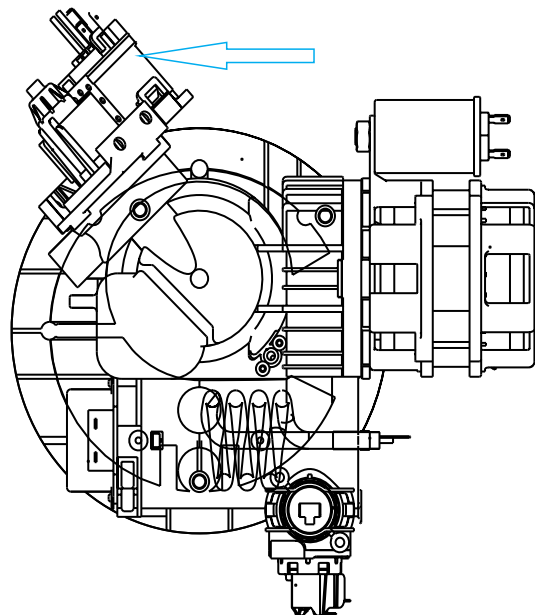

The work principle

Drain pump consists of electrical motor, impeller, inlet and outlet.

Drain pump is a kind of pump driven by permanent magnet synchronous motor. The rotor is made with permanent magnet material, the running inertia of rotor is very small, the stator consist of silicon steel stack and coil. When the drain pump is on power, the rotor will be very easy to start.

The defeat point

1. The motor coil is broken, so the drain pump can't work. It will cause the E2 , E4 or E1 error .
2. The magnetism of motor rotor is weak, so drain pump cannot work. It will cause the E2, E4 or E1 error .
3. The connector is loose, so the drain pump can't work. It will cause the E2, E4 or E1 error .
4. The rotor is locked by residues, so the drain can't work . It will cause the E2, E4 or E1 error .
5. The drain pump assembly rack is loose, it will cause noise.
6. The non-return valve is bad, the remain water is too much.

Explanatory notes: failure of drain pump may cause E1, becaus

Technical data

Nominal voltage	220-240VAC
Frequency	50Hz
Resistance	167 10%Ω
Delivery height	1M
Delivery performance	≥17l/min(230VAC)

Access drain pump

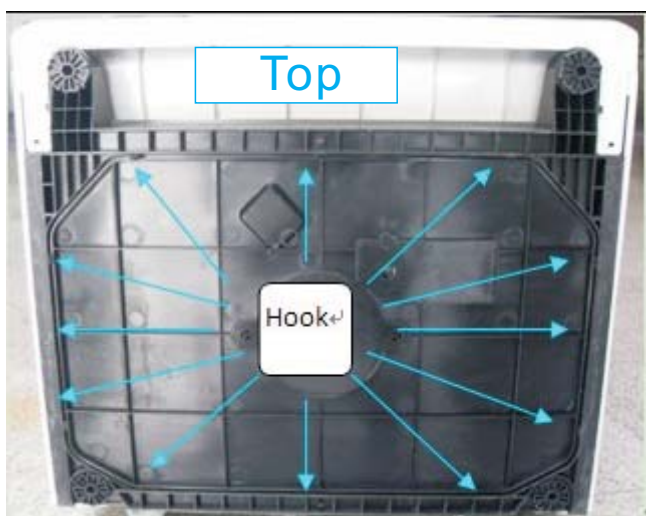

1. Drain off the water in the dishwasher, and disconnect the power supply.
(Note : Make sure to remove remained water in the dishwasher. If not, wet the floor.)
2. Loosen the hooks, and then remove bottom board. (Note: You should first loosen the top hooks, then the left and right hooks. and be care do not break the hook.)
3. Label and disconnect the two terminal lugs from the drain pump.
4. Contrarotate the drain pump to take it off.
5. Reverse the above procedure to install.

Inspect drain pump

Check the electric part

1. Open the protecting box and take out the PCB;
2. With the door closed, unplug the CON3 and ACN wires, then use the multi-meter Ω shelf to measure the red wire (PS) and blue wire (ACN), the normal resistance is about 150Ω to 190Ω .
3. If the measured resistance is not correct, it means the pump coil is broken or connector is loose. In this case, we should check the connection first. If the problem hasn't been solved by re-connection, we should replace the drain pump.
4. If the resistance is OK, but it also can't work, maybe the magnetism is too weak, so we need to replace the drain pump.

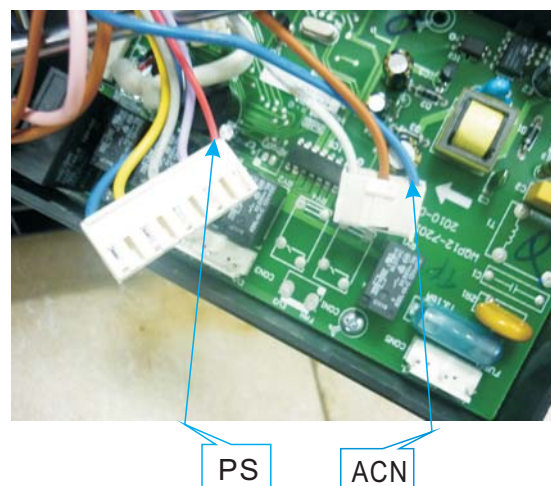

Check the machine part

1. If the electric part is OK, we need to check the machine part.
2. Remove bottom board.
3. If the non-return valve is wrongly assembled, the tub will remain much water. We need to re-assemble the non-return valve.
4. If the drain pump is working, but no water drain out or just a little. We should check the drain hose or drain body.

Location of Heater

Bottom view

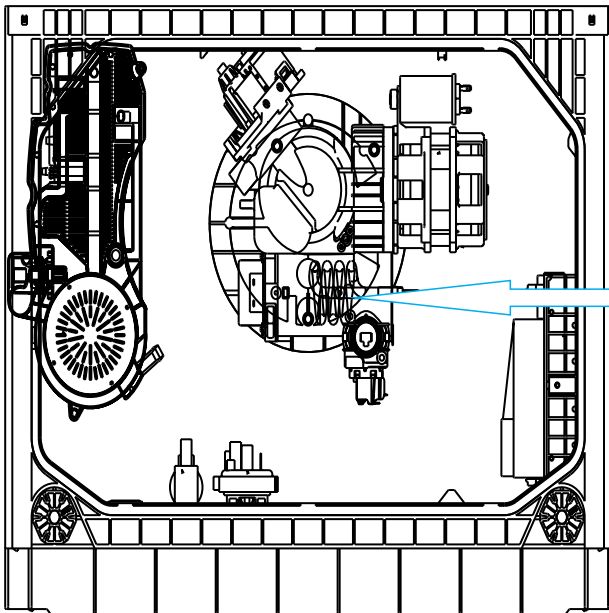

The work principle

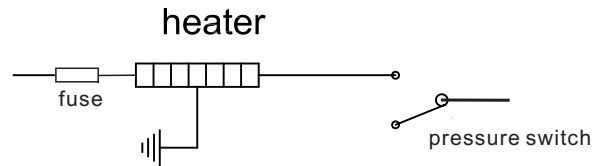

Technical data

Nominal voltage	230VAC
Rating power	1800W
Resistance	29.4 10%Ω
Fuse	167°C

The defeat point

1. The heater coil is broken, so the heater cannot work. It will cause the E3 error.
2. The Fuse is active, so the heater cannot work. It will cause the E3 error.
3. The connector is loose, so the heater cannot work. It will cause the E3 error.

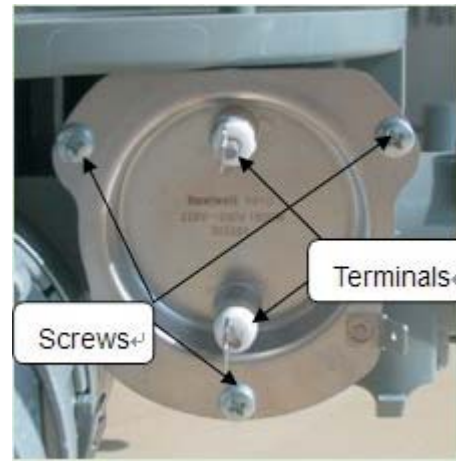
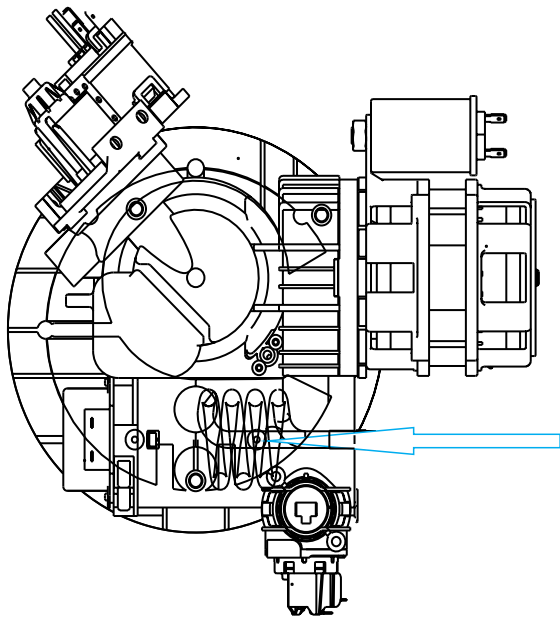

Access heater

1. Drain off the water in the dishwasher, and disconnect the power supply.
(Note : Make sure to remove remained water in the dishwasher. If not, wet the floor)
2. Remove bottom board.
3. Label and disconnect the terminals.
4. Remove the 3 screws for fixing the heating element.
5. Reverse above procedures to install.

Inspect heater

1. Remove bottom board.
2. With the door closed, use the multi-meter Ω shelf to measure resistance between the two terminals shown in above right picture, the resistance is about 29Ω to 31Ω .
3. If the measured resistance is not correct, it means the heater coil or the thermostat is broken, we should replace the heating element or the thermostat.

Location of Washing Pump

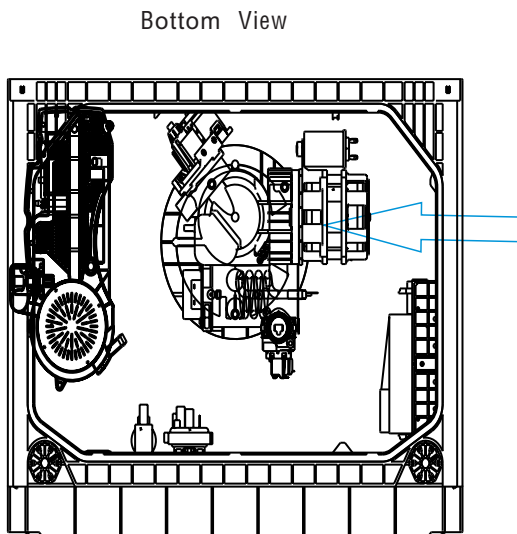

The work principle

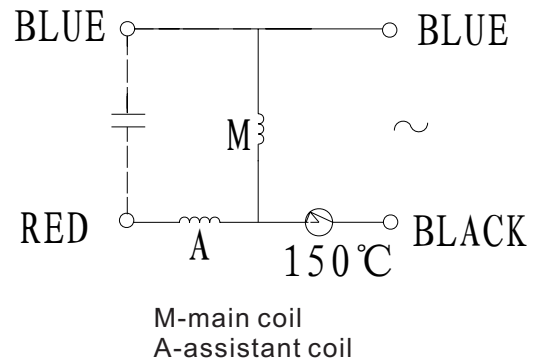

Washing pump is a kind of asynchronism motor with capacitor. The stator consist of silicon steel stack and two coils, main coil and assistant coil .

The defeat point

1. The motor coil is broken, so the wash pump can't work. It will cause E3 error.
2. The motor rotor capacitor is weaken, so washing pump can't start. In this case, it will send out the electromagnetism noise. If it is continue electrifying motor, the thermal protector will work. It will cause E3 error.
3. The connector is loose, the wash pump can't work. It will cause E3 error.
4. The rotor is locked by residues, so the wash pump can't work . It will cause the E3 error.
5. The drain pump assembly bracket is loose, it will cause noise.
6. If the machine hasn't been used for long time, there is a possibility the wash pump can't starting.

Technical data

Models	YXW48-2F-1	YXW48-2F
Nominal voltage	220-240VAC	220-240VAC
Frequency	50Hz	50Hz
Resistance	Main coil: 159.4 10%Ω	Main coil:120.10 7%Ω
	Assistant coil:93.3 10%Ω	Assistant:107.7 7%Ω
Delivery height	1m	1m(230VAC)
Delivery performance	≥50l/min(230VAC)	≥50l/min(230VAC)
Lock rotor current	0.5A 10%	0.85A 10%(230VAC)
Operating current	0.24A 15%	0.37A 10%(230VAC)
Capacitor	3μF /425V	3μF/425V

Access Washing Pump

1. Disconnect power.
2. Remove bottom board.
3. Label and disconnect the 2 terminals to the motor wire connector.
4. Remove the clamp fastening the interconnect hose to the sump.

Caution: The clamp is easily damaged during removal and can't be reused. Replace the old clamp with a new universal clamp.

5. Disconnect the ground wire from the wash pump motor assembly.
6. Remove the motor pump assembly from the dishwasher.
7. Reverse above procedures to install.

Inspect Washing Pump

Check the electric part

1. Open the control panel and take out PCB;
2. With the door closed, unplug the CON5, then use the multi-meter Ω shelf to test resistance between two wires (ML and ACN), the normal resistance is about 100Ω to $170\ \Omega$.
3. If the resistance is not correct, it means the pump coil is broken or the connector is loose, In this case, we should check the connection first. If the problem hasn't been solved by re-connection, we would replace the washing pump.
4. If the resistance is OK but it cannot work, it maybe the capacitor weakly, we need to replace the capacitor.

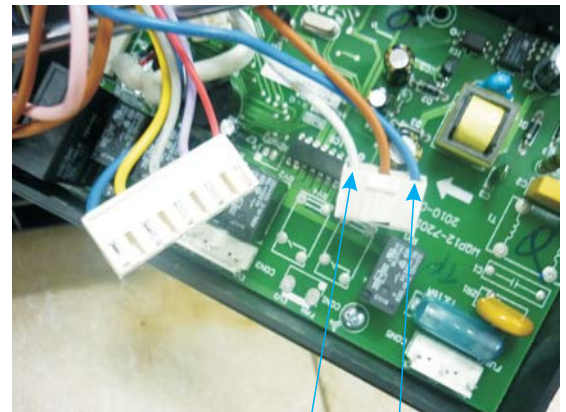

ML

ACN

Check the machine part

1. If the electric part is OK, we need to check the machine part.
2. Remove bottom board.
3. Check the pump assembly, if the bracket is loose, it will bring the noise, we need to tighten it.
4. If the wash pump cannot start and the machine hasn't been used too long, maybe the seal element is bond.
5. If the drain pump is working, but no water out or just a little. We should check the vane wheel.

The work principle

The pressure switch consists of a moving diaphragm and disc which activate a change over contact. The contact can be calibrated to trip and reset at the desired pressure levels, The main application is to control the level of water in appliances. May also provide flood protection.

In our production, May also provide flood protection, like 135/115 serial.

1- COM

2 - NC

3 - NO

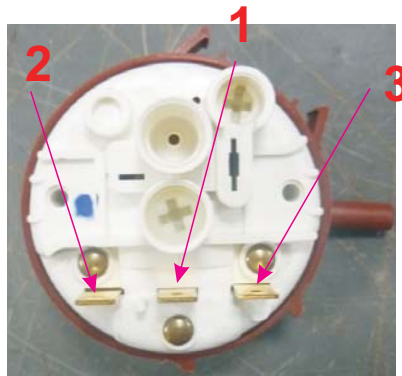

Front view



Back view

Location of NTC

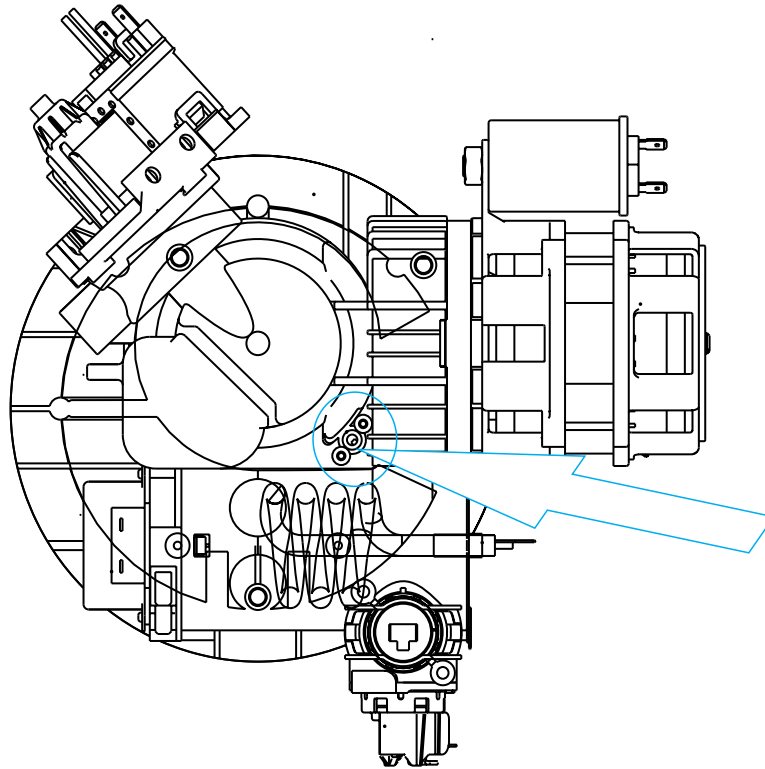

The work principle

Negative Temperature Coefficient Thermistor is integrated into sump, which is used for measuring temperature of water in the tub.

Access NTC

1. Remove bottom board.
2. Remove two screws securing the NTC to sump(shown in above picture).
3. Take out NTC.
4. Reverse the above procedure to install.

Inspect NTC

1. Open the protecting box and take out PCB;
2. With the door closed, unplug the RE connector (shown in below picture), then use the multi-meter Ω shelf to test resistance between two blue wires (RE and GND), the normal resistance is shown in below table.
3. If the resistance is not correct, it means NTC circuit has a problem. In this case, we should check the connection first. If the problem hasn't been solved by re-connection, we would replace the NTC.

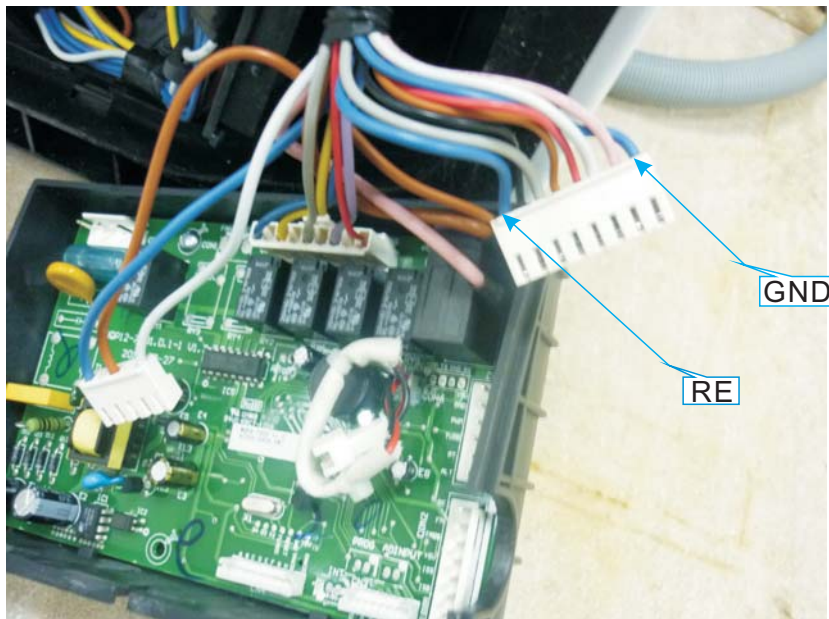

NTC resistance table

NTC	15°C	17.48K Ω
	20°C	12.12K Ω
	25°C	10K Ω
	30°C	8.299K Ω
	40°C	5.807K Ω
	50°C	4.144K Ω
	60°C	3.011K Ω
	70°C	2.224K Ω
	80°C	1.667K Ω
	85°C	1.451K Ω

Location of Flowmeter

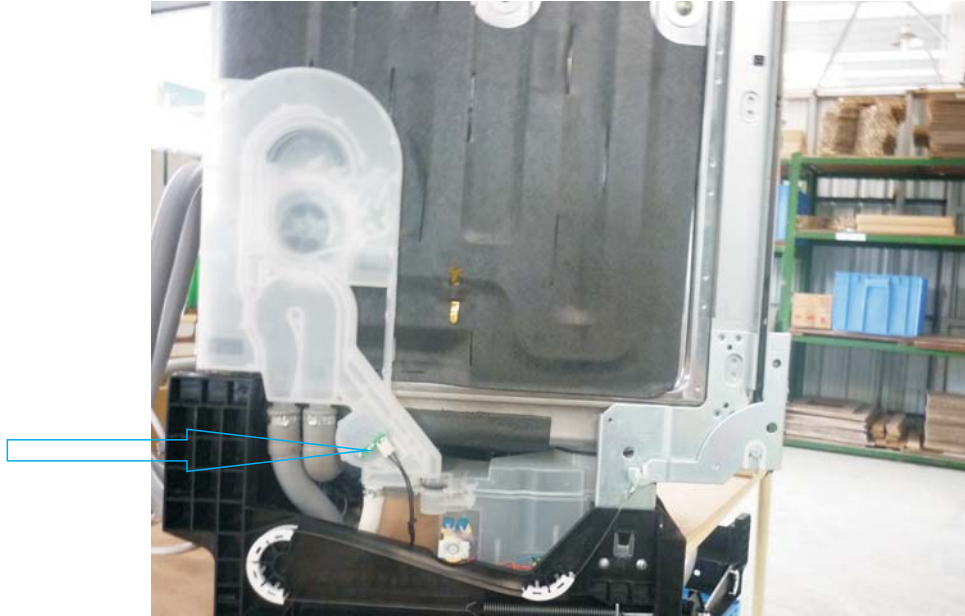

The work principle

Flowmeter is integrated into Air Breaker. Function of Flowmeter is measure how much water has entered in appliance. it consists of impeller, tongue tube and terminal, etc.

When water pass through the flowmeter, moving water can rotate magnetic impeller, the tongue tube can sense the impeller's magnetic and send electronic pulses.



Flowmeter

Access Flowmeter

1. Remove the baseboard, top panel and left side panel.
2. Remove the plastic nut inside tub, which secures the air breaker to tub. (Because flowmeter is integrated into air breaker, replace air breaker if flowmeter has failure.)
3. Disconnect the wire and remove clamp fastening hose to air breaker.
4. Take out air breaker.
5. Reverse the above procedure to install.

Inspect Flowmeter

1. Open the protecting box and take out PCB;
2. With the door closed, unplug the CON2 wire (shown in below picture), then use the multi-meter Diode shelf to test between black wire (FM) and blue wire (GND) to confirm whether electrical pulse is sent out while water is passing through flowmeter, or not.
3. If there is continual electrical pulse, the multi-meter will send out sound "de" continually.
4. If there is no electrical pulse, the multi-meter will not send sound. In this case, it means something wrong with flowmeter circuit. We should check the connection first. If the problem hasn't been solved by re-connection, we should replace the air breaker..

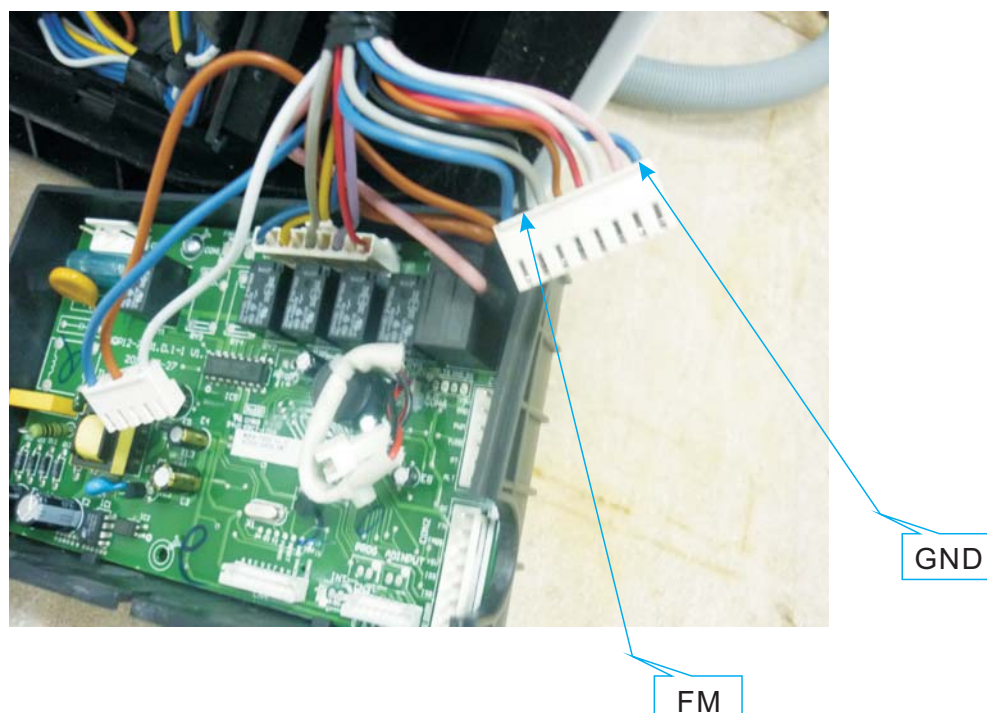

Location of Safety Hose

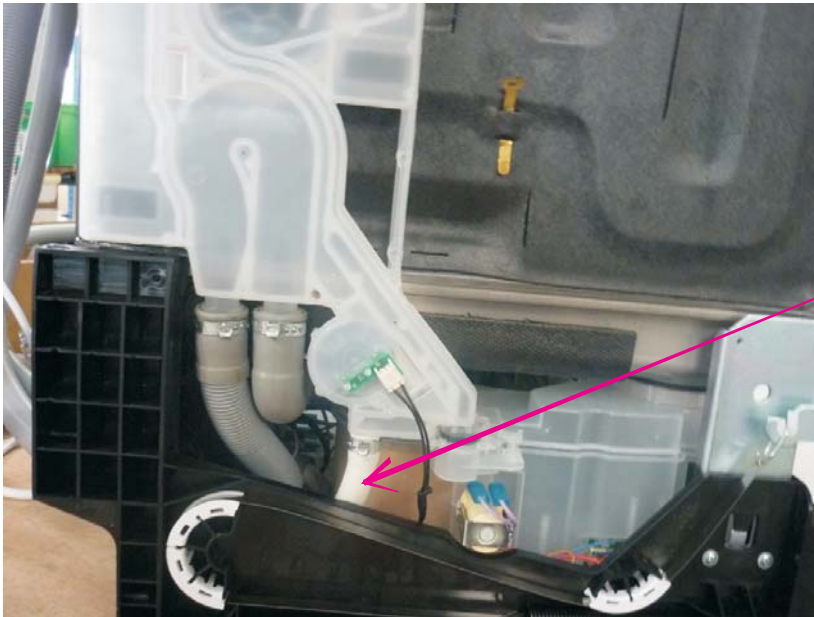

Electronic Aquastop Hose

The work principle

Mechanical Aquastop Hose

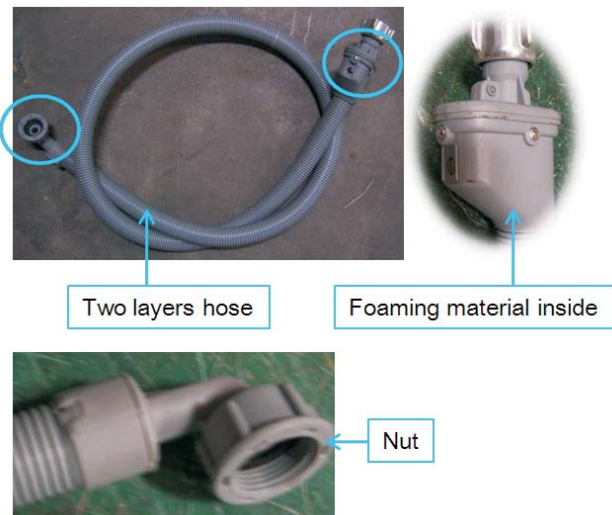

Electronic Aquastop Hose

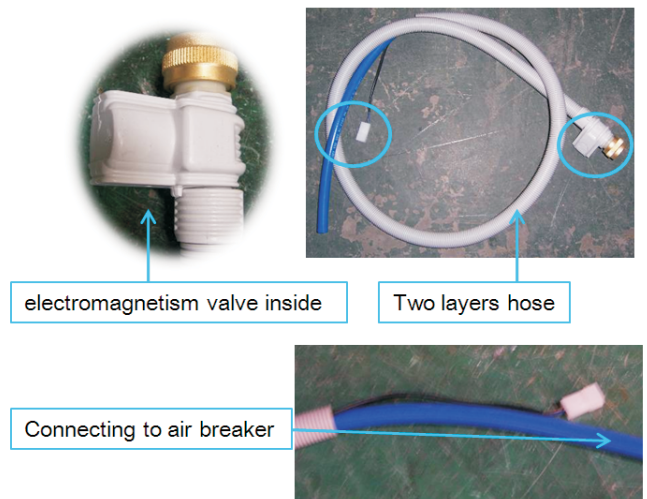

There are two types of Safety Hose, mechanical Aquastop hose and electronic Aquastop hose, which have different principles and assembly modes.

Mechanical Aquastop safety hose has two layers. If water leak and fill the air space between two layers, the foaming material will expand and lock the hose. In this situation, the machine might set off E1 alarm.

Electronic Aquastop safety hose also has two layers. But the difference from mechanical is that if the water leak and flow on the bottom tray, the flooding pressure switch on the tray will act, the electromagnetic valve on the hose will cut off the water road and the machine will set off E4 alarm.

Access Safety Hose

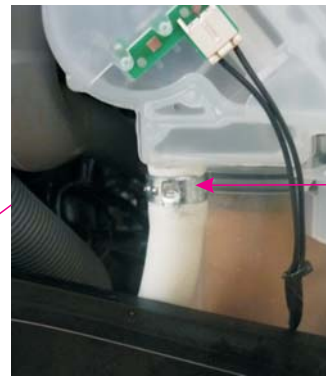
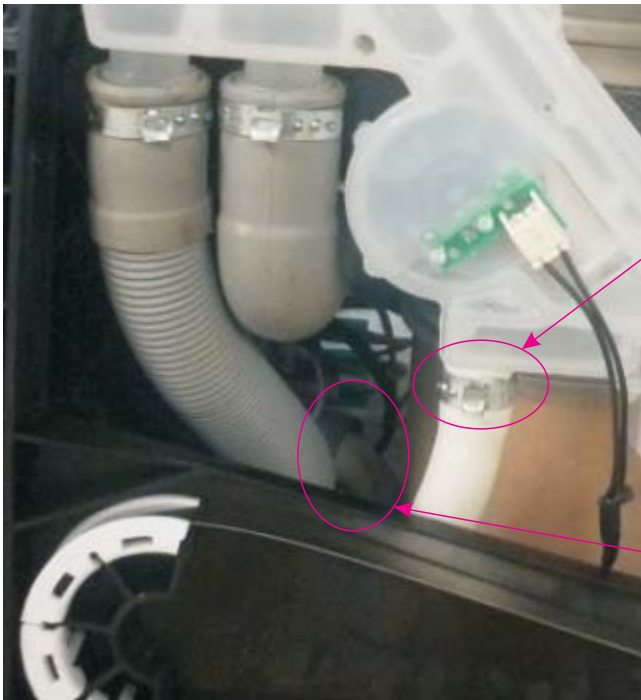

wire connector
(no need to distinguish
positive and negative electrode)



1. Remove baseboard, side baseboard, top panel and left side panel.
2. Remove clamp, cut the bound belt and disconnect the wire connector. Then the Inlet hose can be pulled out.
3. Reverse the above procedure to assemble.

Mechanical Aquastop Hose

Mechanical Aquastop hose is connected to appliance just as universal water inlet hose.

Inspect Safety Hose

Electronic Aquastop Hose

1. Open the protecting box and take out the PCB;
2. With the door closed, unplug the CON3 and ACN wires, then use the multi-meter Ω shelf to measure resistance between the blue wire (EV1) and blue wire (ACN). Open circuit and short circuit are both incorrect.
3. If the measured resistance is not correct, it means the valve coil is broken or the connector is loose. In this case, we should check the connection first. If the problem hasn't been solved by re-connection, we should replace the safety hose.

Mechanical Aquastop Hose

Maybe moisture absorption of foaming material in mechanical device cause a self-lock fault (can't fill the water) and this lock is non-resettable.

Test Program

In order to check the operation of components of appliance and find out the malfunction, we designed this program for technician.

How to activate Test Program

Test Program Operation	
	7313B
How to activate Test Program	With door opened, Program + Power
Start Test Program	Close the door
Jump into next step	Program
E1	E1
E2	/
E3	E3
E4	E4
E6	E6
E7	E7

To activate test program, with the door opened and machine off, hold down the Program button and press the POWER button until the machine enter into Test Program. The appliance will pause and stand by(as step 00). Then close the door to start the Test Program.

During test program running, you can press Program button to jump into next step(except inlet valve step).

Note: The way to activate test program is slightly different between different models.

Procedure of Test Program (for models controlling water filling by flowmeter)			
No.	Display on the screen	Process	Description
0	8:88	Intialization	Power on, stand by
1	05	Inlet Valve	Open inlet valve and feeds with 3.6L water.
2	04/Temperature value	Washing Pump and Heating Element	Run washing pump and 10s later run heating element until the water temperature reaches 57°C. Then the machine will pause. Press Program button to jump into the next step.
3	03	Washing Pump and Dispenser	Dispenser will act at once for 45s, and washing pump will run for 10s in this step.
4	02	Regeneration Valve	Open regeneration valve for 30s.
5	01	Drain Pump	Drain for 30s.
6	F*	finish	Buzz one sound, stop, and stand by.

How to know which error code has occurred

To know which error code has occurred, refer to the previous table named Test Program Operation.

Take 7201 for example, If the error 1 has happened, the buzzer would alarm for 30 seconds and “E1” would be shown on display. Other error alarms would be shown in the same manner.

Take 7303 for example, if the error 7 has happened, the buzzer would alarm for 30 seconds and the Glass, 1 hour and Rapid indicators would flash simultaneously. Other error alarms can be deduced from this.



	Glass	1 hour	Rapid	binary numeral	decimal numeral
E1	0	0	1	001	1
E3	0	1	1	011	3
E4	1	0	0	100	4
E6	1	1	0	110	6
E7	1	1	1	111	7

The corresponding relation between indicator combination and error code shown in above figure.

Notice: the majority of models are follow this regulation.

Attention

Priority level of E4 is the highest. E4 operation is valid after other error operations have done. When E4 operation has done, all the others are invalid.

In test program, E1, E3, E4, E6 and E7 are valid.

Note:

How does the appliance react when error code occurred

E1 Water filling exceed pre-set time

If the inlet valve has been opened for 4 minutes but the water quantity hasn't reached the desired value(measure by pluses), E1 would occur.

When E1 occurs, the drain pump will run until flowmeter keep motionless for 2 minutes and all the other components will be stopped immediately. At the same time, the buzzer will alarm for 30 seconds and error 1 will be shown.

E3 Heating exceed pre-set time

If the heating element has been working for 60 minutes but the water temperature detected by NTC hasn't reached desired value. E3 would occur.

When E3 occurs, the drain pump will run until flowmeter keep motionless for 2 minutes. and all the other components will be stopped immediately. At the same time, the buzzer will alarm for 30 seconds and the error 3 will be shown.

E4 Overflow

At any time, if overflow micro-switch act and keep for longer than 2 seconds, the E4 would occur. When E4 occurs, the drain pump will run until flowmeter keep motionless for 2 minutes . and all the other components will be stopped immediately.

At the same time, the buzzer will alarm for 30 seconds and error 4 will be shown.

Note: Priority level of E4 is the highest. E4 operation is valid after other error operations have done. When E4 operation has done, all the others are invalid.

E6 Open-circuit failure of thermistor

In test program, once open-circuit failure of thermistor is detected by controller, the E6 would occur. When E6 occurs, the drain pump will run until flowmeter keep motionless for 2 minutes. and all the other components will be stopped immediately.

At the same time, the buzzer will alarm for 30 seconds and error 6 will be shown.

E7 Short-circuit failure of thermistor

In test program, once short-circuit failure of thermistor is detected by controller, the E7 would occur. When E7 occurs, the drain pump will run until flowmeter keep motionless for 2 minutes . and all the other components will be stopped immediately. At the same time, the buzzer will alarm for 30 seconds and error 7 will be shown.

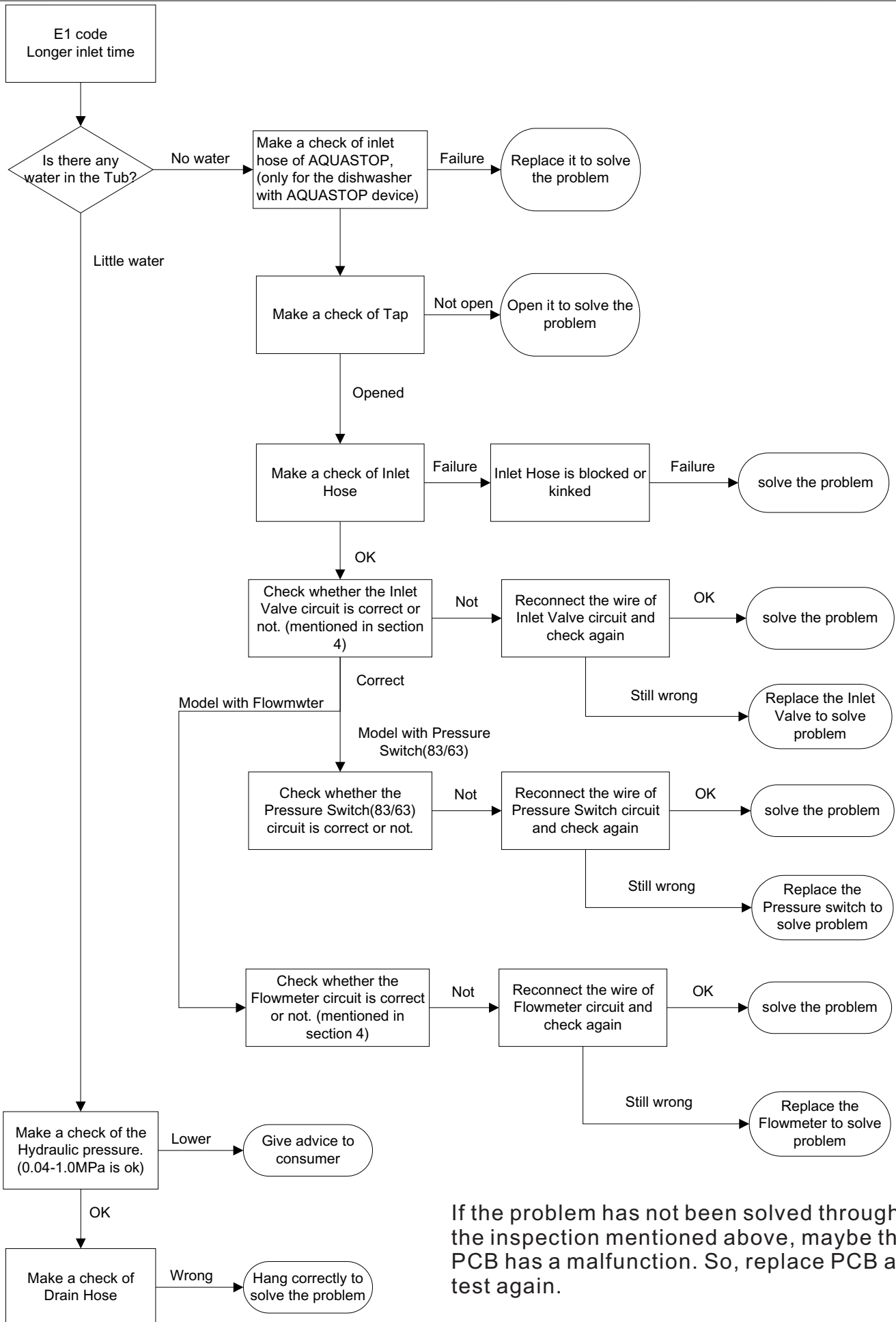

If the problem has not been solved through all the inspection mentioned above, maybe the PCB has a malfunction. So, replace PCB and test again.

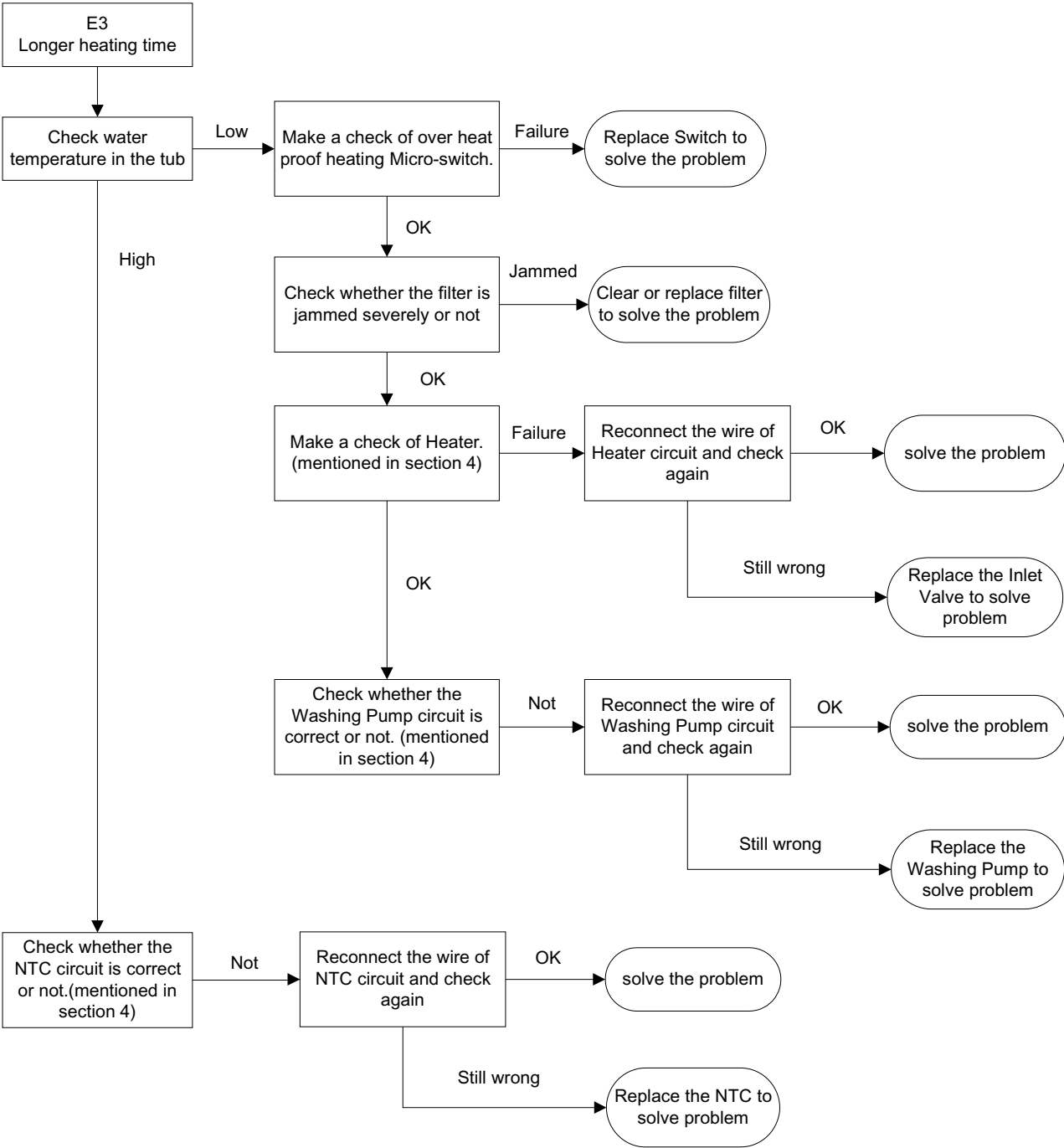

E4 tree -> Inspection

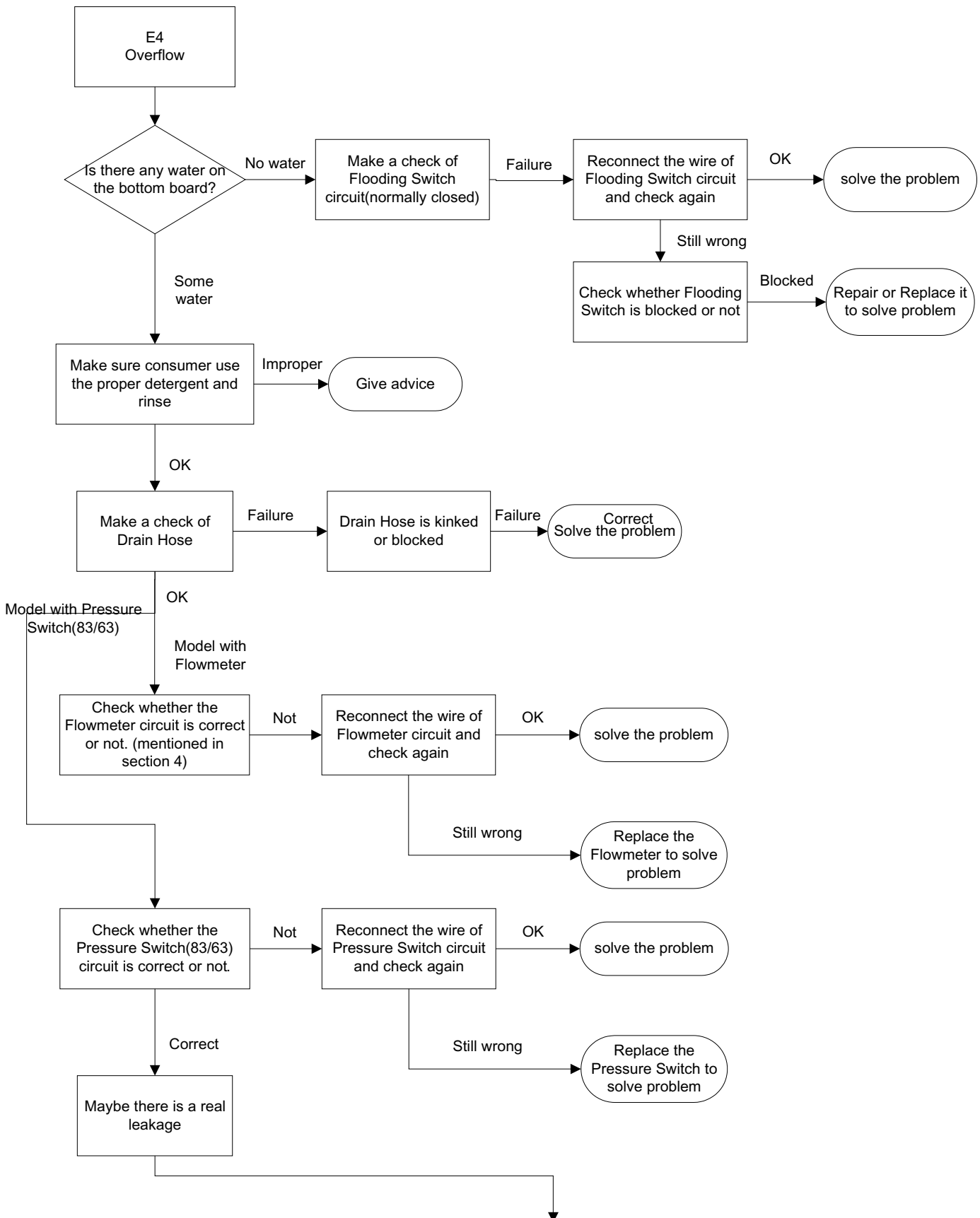

Do as follows

Remove two side panels

Remove the water from the bottom board and make sure there is no water at the bottom board.

Restart the dishwasher with a strong or standard wash program as a leakage could easily repeat at a higher temperature and after a long period of running time.

Observe the bottom tray every twenty minutes.

If any water appears, you will find out which areas, such as motor, drain pump, sump, softener, and hoses between them, and also clips at the end of each hose, besides the weld seam at the bottom of the tub.

If hours passed, but no water comes out, you should stop the dishwasher with sufficient water in the inner tub, and observe it again after leaving it alone for one to two hours.

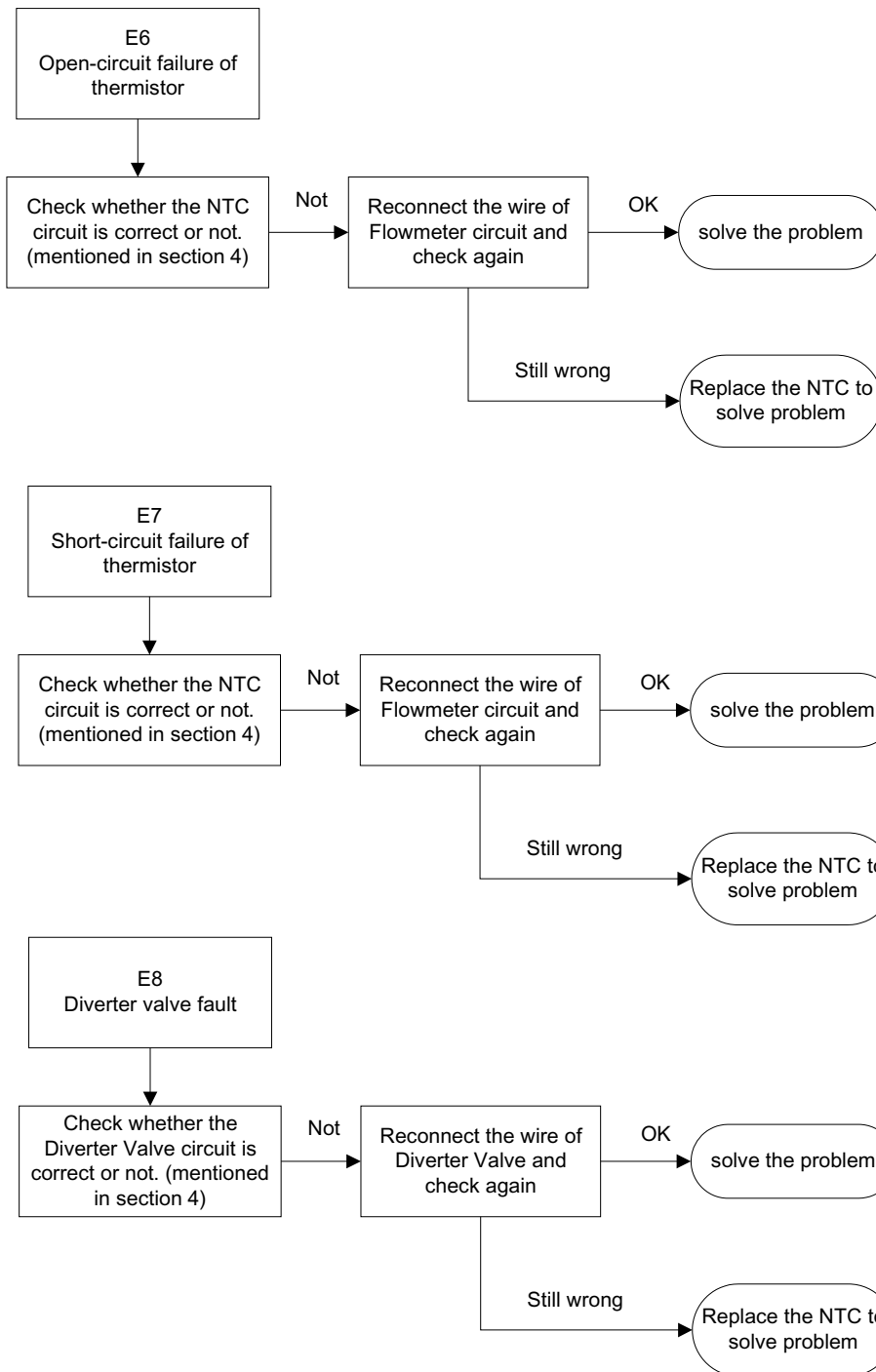

If the problem has not been solved through all the inspection mentioned above, maybe the PCB has a malfunction. So, replace PCB and test again.

Caution:

Because the real situation is unpredictable, inspection trees mentioned in this manual are for reference only.

symptom	possible reason	analysis	operation	remedy
E1 longer inlet time	check the AQUA STOP hose	defective AQUA STOP hose might cut off the water inlet route	for mechanical AQUA STOP hose, check whether the mechanical device is lock or not	replace the hose
	check the water supply	the tap isn't open	for electronic AQUA STOP hose, check whether the valve circuit is ok or not	reconnect or replace the hose
	check the inlet	lower hydraulic pressure	check whether the tap open or not	give advice
	check the inlet valve	inlet hose is blocked or kinked	make sure the hydraulic pressure in the range from 0.04 to 1.0 Mpa	give advice
	check the flowmeter	loosing connection or defective inlet valve might cause the E1 alarm	unblock or unkink	unblock or unkink
	check the pressure switch (83/63)	for models with flowmeter, defective flowmeter might cause the E1 alarm	check the circuit of inlet valve	reconnect or replace the valve
	check the drain	for models controlling water filling by pressure switch, defective pressure switch might cause the E1 alarm	check the circuit of flowmeter	reconnect or replace flowmeter
	check the pressure switch (140/120)	wrong installation of drain hose might cause water siphon out	check the circuit of pressure switch	reconnect or replace the pressure switch
	check the PCB	defective PCB might cause the E1 alarm	make sure it is intalled properly.(refer to instruction manual)	reinstall drain hose
			listen the sound to check whether the drain pump is run or not	replace the pressure switch (140/120)
			defective PCB might cause the E1 alarm	reconnect or replace PCB
				e

e

	check whether the appliance is level	if appliance is not level, it might cause the E4 alarm	make sure the appliance is level	level appliance
E4 overflow	check the drain pump	defective drain pump might cause the E4 alarm	the first step of all the washing program is drain, which could be used to test whether drain pump work normally or not	replace the drain pump
	check the amount of filling water	too much filling water could make a overflow	for models controlling water filling by pressure switch(83/63), run test program and check whether the amount of filling water is normal or not.	repace the pressure switch(83/63)
	check the float microswitch	sticking float microswitch could cause the E4 alarm	for models controlling water filling by flowmeter, run test program and check whether the amount of filling water is	replace the flowmeter
	find where leakage is	if there is a real leakage, finding where leakage is and solving the problem would be	disassemble the bottom tray and check whether the float microswitch moves freely up and down	repair or replace the float microswitch
			to find and solve problem, do as suggestion mentioned in service manual	repair or replace the defective component
E6 & E7 open-circuit & short-circuit	check the NTC	if the appliance detect the malfunction of NTC thermistor, E6 or E7 would be set off	check the NTC circuit and measure the resistance of NTC thermistor	reconnect or replace the NTC thermistor
	check the PCB	if the NTC thermistor is ok, but the alarm still be set off, the PCB might have defect	change the PCB to see if the appliance is run normally	reconnect or replace PCB
	check the loading	improper loading could block the spray arm, so give advice to end customer on how to load dishes and silverware peoperly.	following the advice on how to load mentioned in instruction manual, which is the necessary condition of getting good washing performance	give advice
	check filter	severely jammed filter might cause E3 alarm, so give advice to end customer on clean regularly the interior of dishwahser.	Advice: Even though a dishwasher is constantly being pounded with water and soap, it needs an occasional cleaning. Food particles, hard water deposits, mildew, mold and bacteria can and do build up along the surfaces and in the crevices of a dishwasher. Cleaning a dishwasher regularly will keep it functioning properly, keep your family healthy and safe...and keep your dishes coming out sparkling	clean the filter and give advice
	check the using program	improper program might cause poor performance		

check the use of detergent and rinse	improper amount of detergent and rinse aid and poor quality detergent and rinse aid might cause poor performance	refer to instruction manual	give advice
check the setting of salt consumption	improper salt consumption might cause the poor performance	Observe whether there are water spots or white film on washed dishes and glass which caused by hard water mineral. If water is too hard, there is a need to adjust salt consumption to adopt to the situation.(refer to instruction)	adjust salt consumption
check dispenser	malfunction of dispenser might cause the poor performance	Run the test program to see whether dispenser open normally.	replace the dispenser
poor washing performance		make sure the appliance is level	level appliance
		wrong installation of drain hose might cause water siphon out, so make sure it is installed properly.(refer to instruction)	reinstall drain hose
		low hydraulic pressure might cause the less filling water, so make sure the hydraulic pressure in the range from 0.04 to	give advice
		for models controlling water filling by flowmeter, defective flowmeter might cause less filling water. When you have eliminated other causes of less water, you could roughly judge the flowmeter is something wrong.	replace flowmeter
check the water level	less water might cause the poor performance	for models controlling water filling by pressure switch(83/63), defective pressure switch might cause less filling water. When you have eliminated other causes of less water, you could roughly judge the flowmeter is something wrong.	replace pressure switch
check heater and NTC	malfunction of heater or NTC might cause E3 alarm	When you have eliminated other causes of less water, you could roughly judge the pressure switch is something wrong. defective PCB also might cause less filling water, but its probability is small. So, the last choose is replace PCB.	replace PCB
check washing pump	washing pump not running	measure temperature of water in tub continuously when test program is running to see whether temperature increasing (aproximate 2 °C/min) is normal and the appliance pause when the water temperature reach 60 degreee or not. listen to the sound of appliance to see whether washing pump run or not	replace the defective component replace the washing pump

poor drying performance	check loading	improper loading might cause water remains on the dishes. Make sure tilt the dishes and load the glass bottom-side-up.	following the advice on how to load mentioned in instruction manual, which is the necessary condition of getting good drying performance	give advice
	check the using program	improper program might cause poor performance	refer to instruction manual	give advice
	check rinse aid dispenser	Rinse aid is formulated to ensure that food and chemical residues are not redeposited on your dishes during the final rinse cycle and dishwasher get expected drying performance. Malfunction of dispenser might cause the rinse	make sure the rinse aid container is not empty and rinse aid is normally release in the cycle.	fill rinse aid or replace dispenser
	-	get better drying performance	The air drying process can be speeded up if you open the dishwasher just after it is finished and the dishes are still hot. This will allow the moist air to leave the dishwasher as the dishes cool and dry.	give advice
noise	check whether the noise is normal	some audible sound are normal	-	give advice
	check the loading	dishes are not secure in the rack or something small has dropped	ensure everything is secured in the dishwasher	reload and give advice
	check the washing pump	malfunction of washing pump might make a abnormal noise	check the washing motor whether run normally	replace washing pump
	check the drain pump	blocked or defective drain pump might make a abnormal noise	check the drain motor whether run correctly	replace drain pump