



RFZ71SS

Caple free standing freezer



Technical information

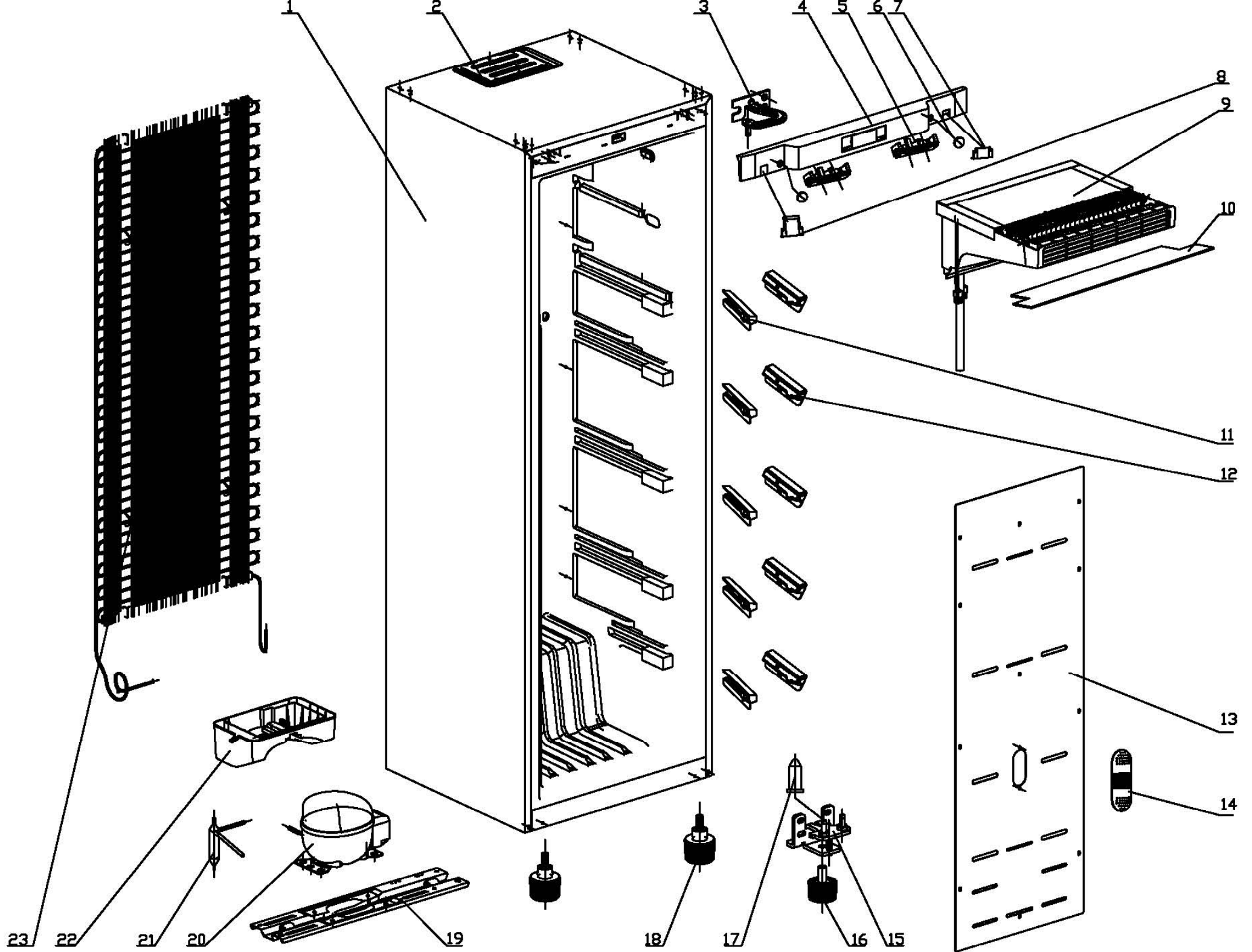

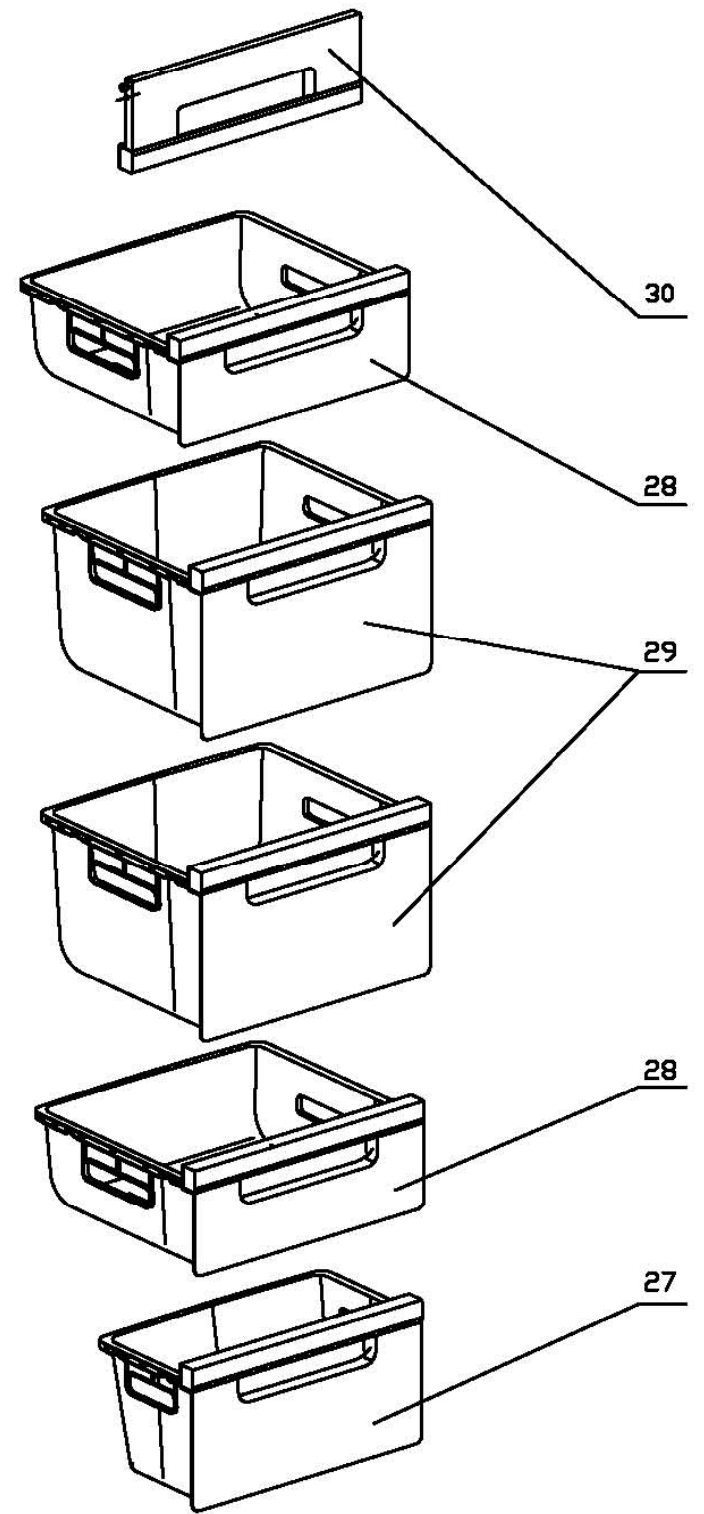
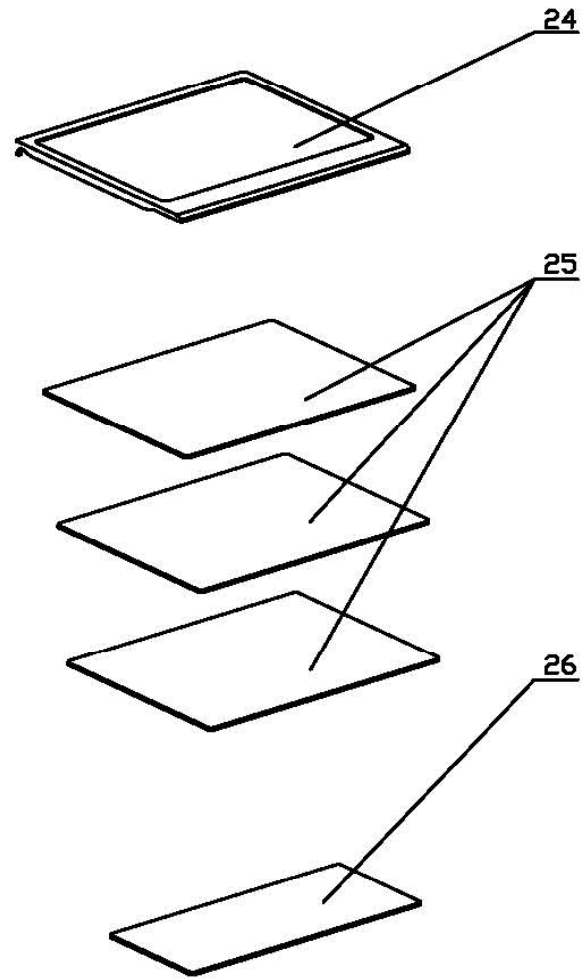
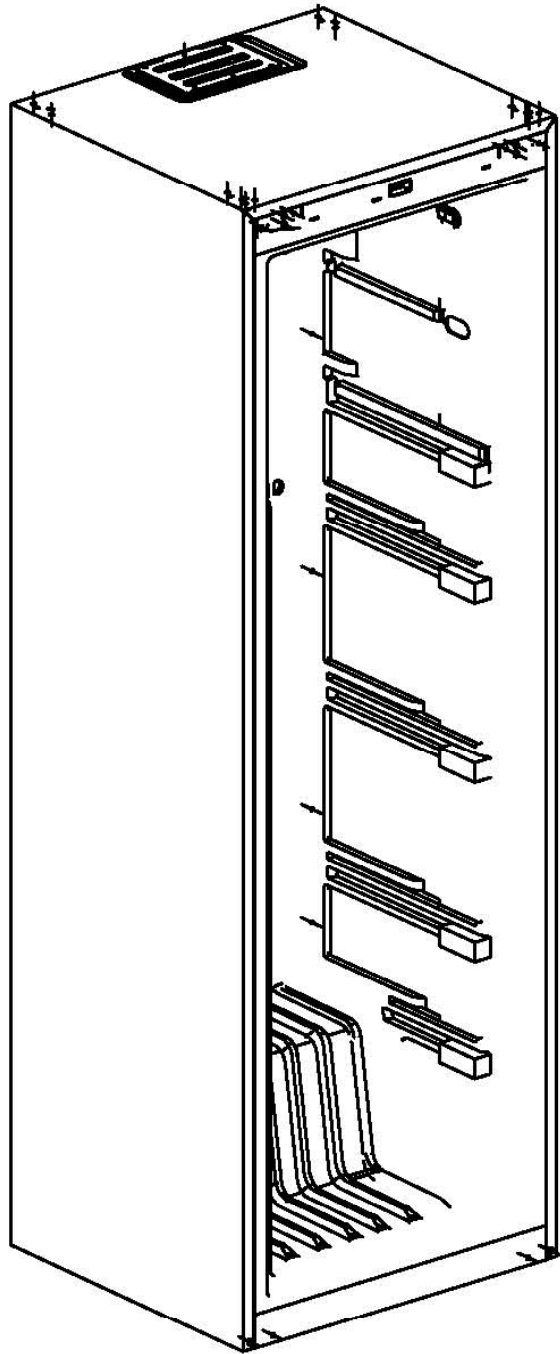

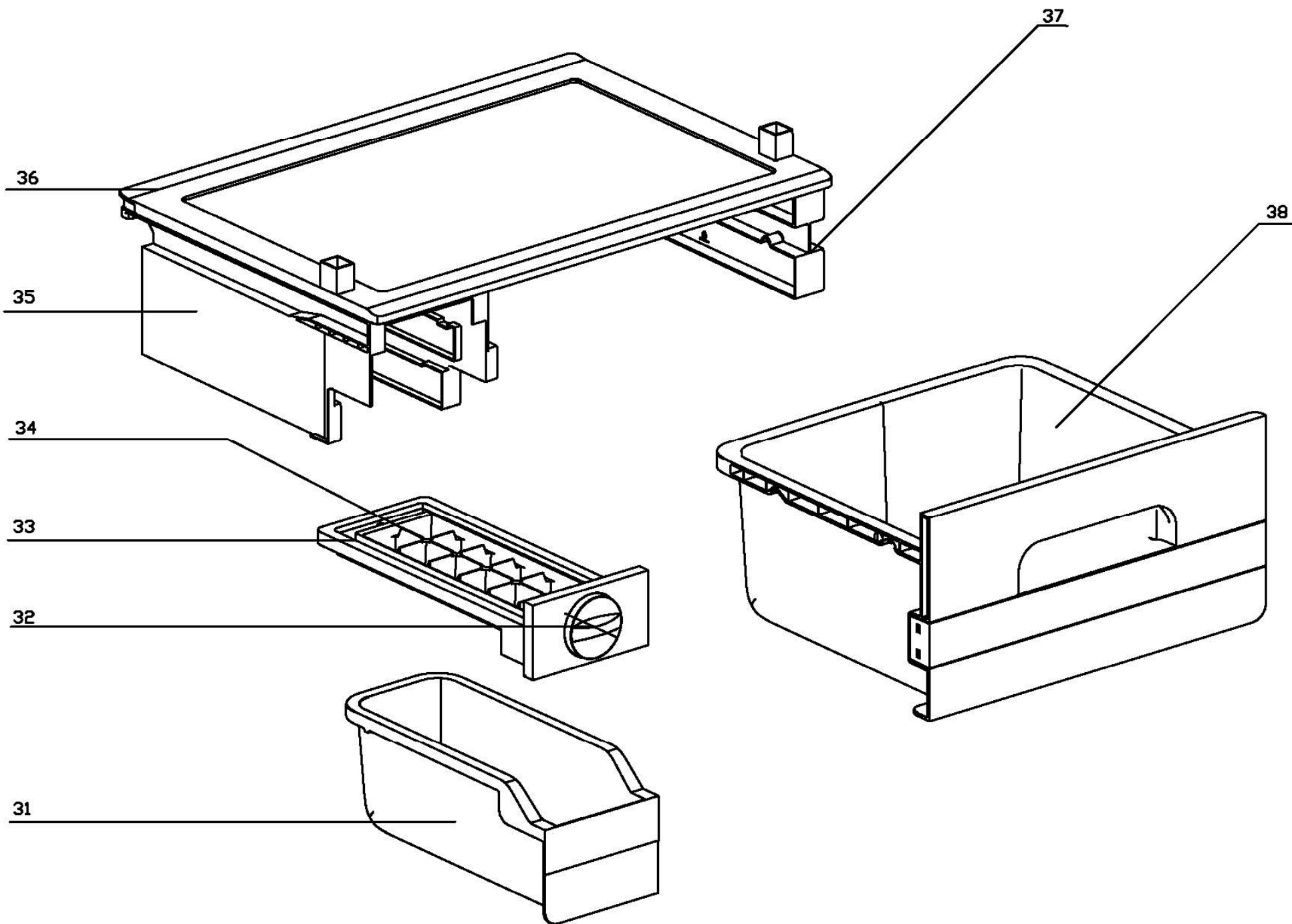

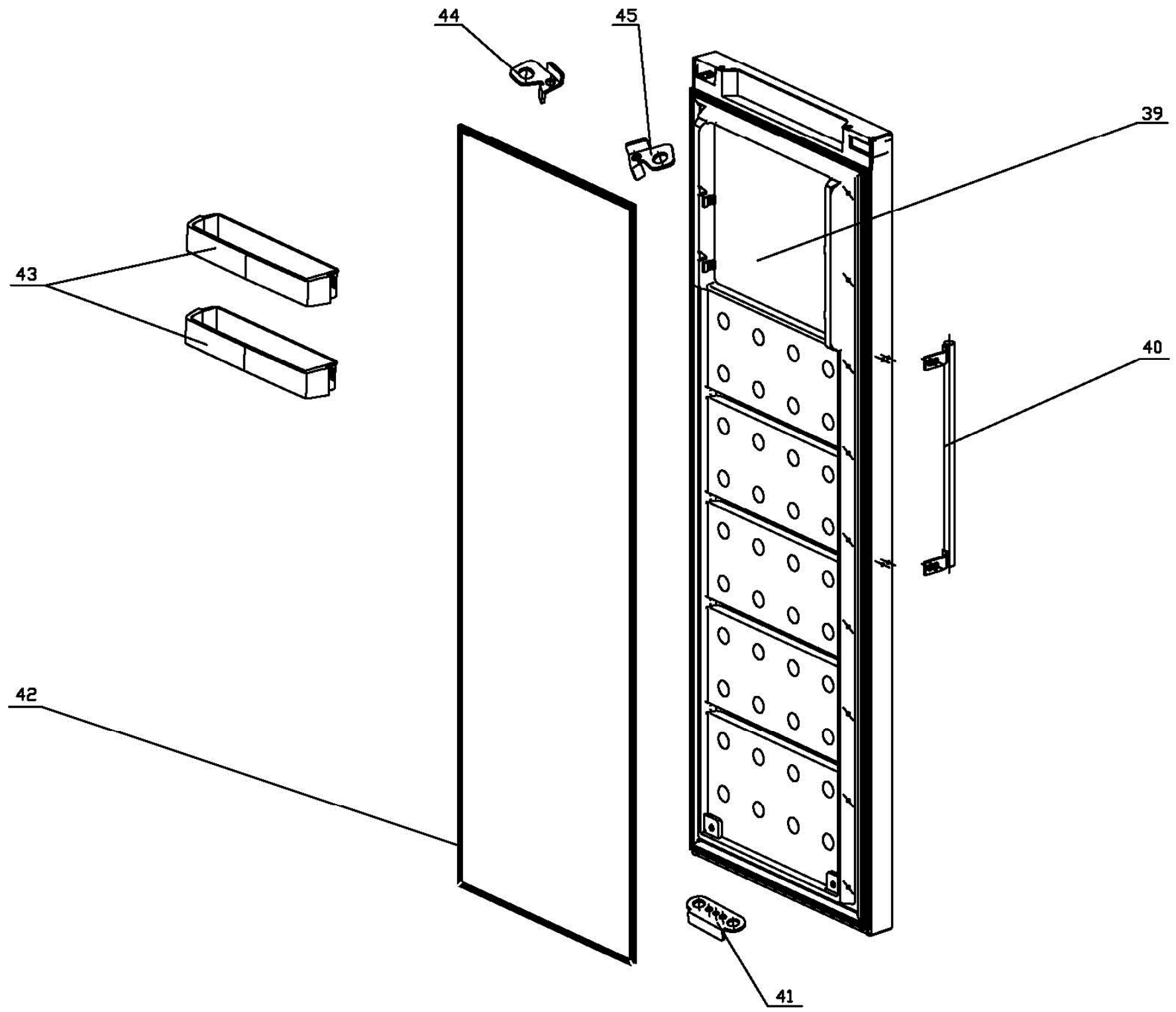



RFZ71SS - Caple free standing freezer

Item	Part Code	Description	Qty
1	50370503000E	cabinet assembly foamed	1
2	501126000001	main control PCB mounting-box cover	1
3	50290504000A	top hinge assembly	1
4	503326030001	control board assembly	1
5	50112601000E	LED cover	2
6	501129210021	screw cap	2
7	50112601000K	left top hinge cover	1
8	50112601000J	right top hinge cover	1
9	501526030004	f upper air channel assembly	1
10	502101030002	air duct aluminum foil	1
11	501126030029	drawer right stopper	5
12	501126030028	drawer left stopper	5
13	501126030013	air duct cover	1
14	501125810006	sensor box cover	1
15	50290504000B	bottom hinge assembly	1
16	501119210059	adjustable foot	1
17	501123110005	hinge shaft sleeve	2
18	501121000010	adjustable foot	2
19	500728010040	compressor mounting panel	1
20	501440430001	compressor assembly	1
21	501602000045	filter	1
22	501126030020	drain tray	1
23	501726030001	wire tube condenser assembly	1
24	503602030006	glass shelf assembly	1
25	503602030008	glass shelf	3
26	503602030009	glass shelf	1
27	50112603001B	F bottom drawer assembly	1
28	50112603001C	F top drawer assembly	2
29	50112603001A	F middle drawer assembly	2
30	50112603000S	flip	1
31	50112603001N	ice box	1
32	5011320102AL	ice tray desmodium	1
33	50113201029A	rotation ice tray bracket	1
34	501132010299	ice tray	1
35	50112603000X	ice-maker vertical shelf	1
36	50112603000V	I/M shelf main body	1
37	50112603001L	I/M frame	1
38	50112603000K	I/M drawer assembly	1
39	50370013013C	F door assembly	1
40	50290401002T	door handle assembly	1
41	500726030005	door block	1
42	50113504000G	door seal assembly	1
43	501126030019	tray	2



RFZ71SS - Caple free standing freezer

Item	Part Code	Description	Qty
44	500726030005	door block	1
45	500726030006	door block	1