



CAFF205SS

Caple Side by side Fridge Freezer



Technical information



New product information sheet

Product name: CAFF205SS
Description: Caple Side by side Fridge Freezer
Product code: CAFF205SS

Compressor	CHK099EV
Climate Class	ST/N
Protection Against Electric Shock	I
Rated Voltage/Frequency	AC220-240V/50Hz
Rated Power(W)	118W
Rated Defrost Power(W)	260W
Lamp Rated Power(W)	1W
Rated Current(A)	1.7A
Foaming Agent	Cyclopentane
Energy Consumption(kW·h/24h)	1.17kW·h/24h
Energy Efficiency Class	A+
Total Gross Volume(L)	545L
Gross Freezer Volume(L)	198L
Total Storage Volume(L)	515L
Freezer Storage Volume(L)	175L
Refrigerator Storage Volume(L)	340L
variable temperature compartment / two-star compartment storage volume	15L
Refrigerant,Amount	R600a,75g
Freezing Capacity(kg/24h)	10kg/24h
temperature rise value	350min
Net Weight(kg)	106kg
Gross Weight(kg)	116
Noise	47dB(A)
Product Dimensions(mm)(wxdxh)	902x750x1760
Carton Dimensions(mm)(WxDxH)	963x778x1830
Packing Dimensions(mm)(WxDxH1)	963x778x1855
Stacking layers	2

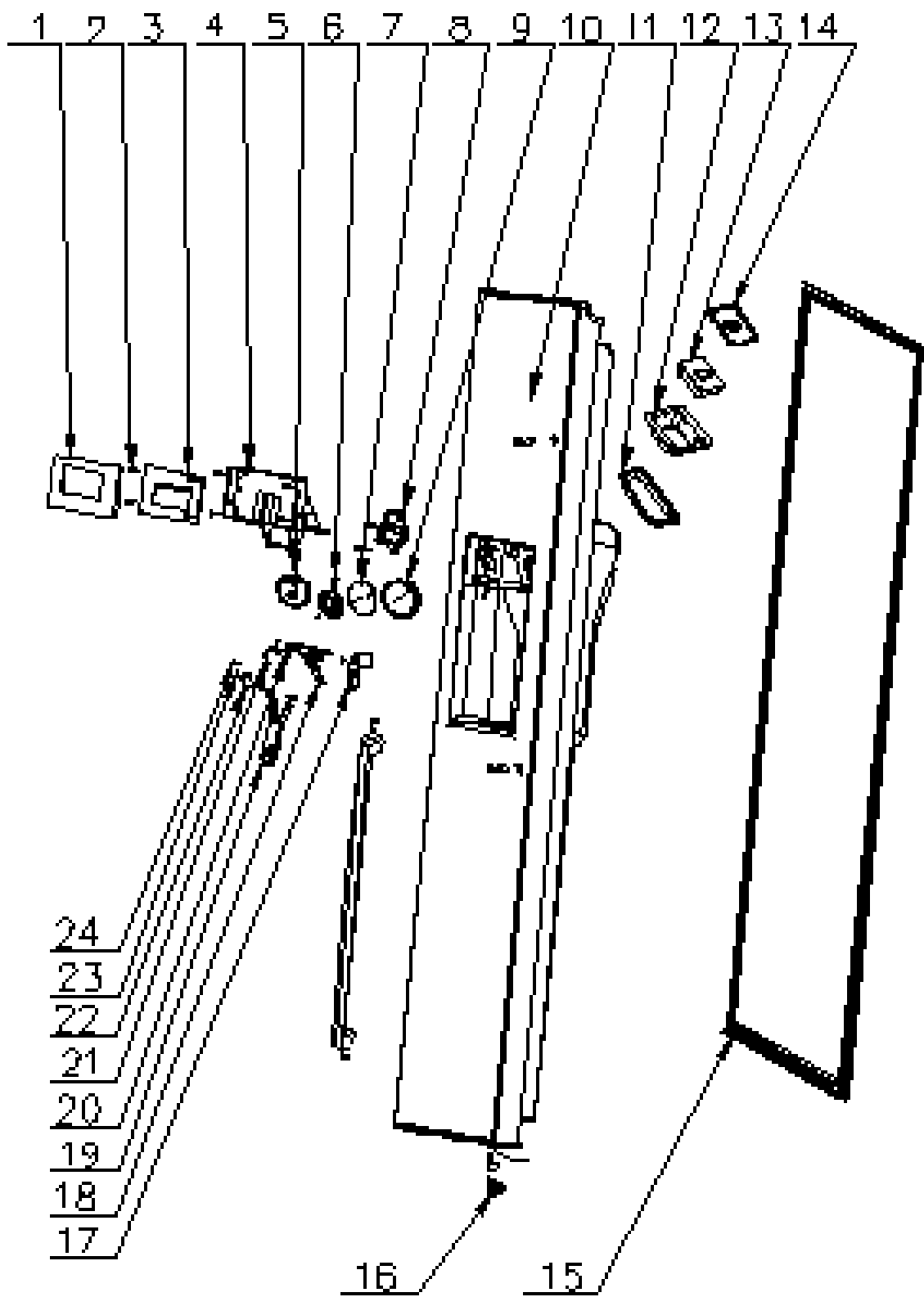

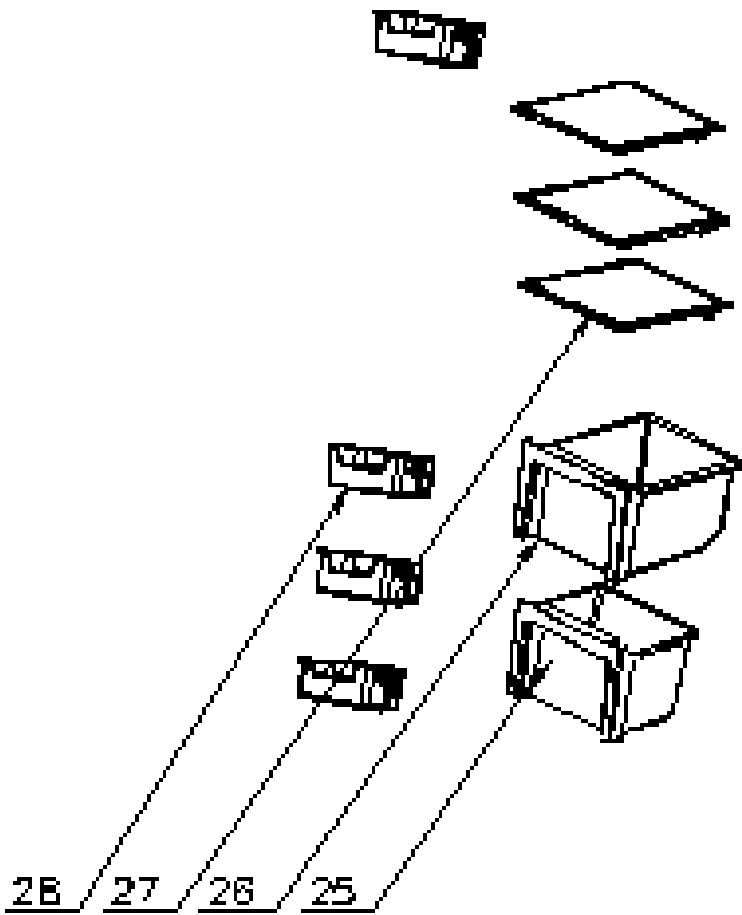

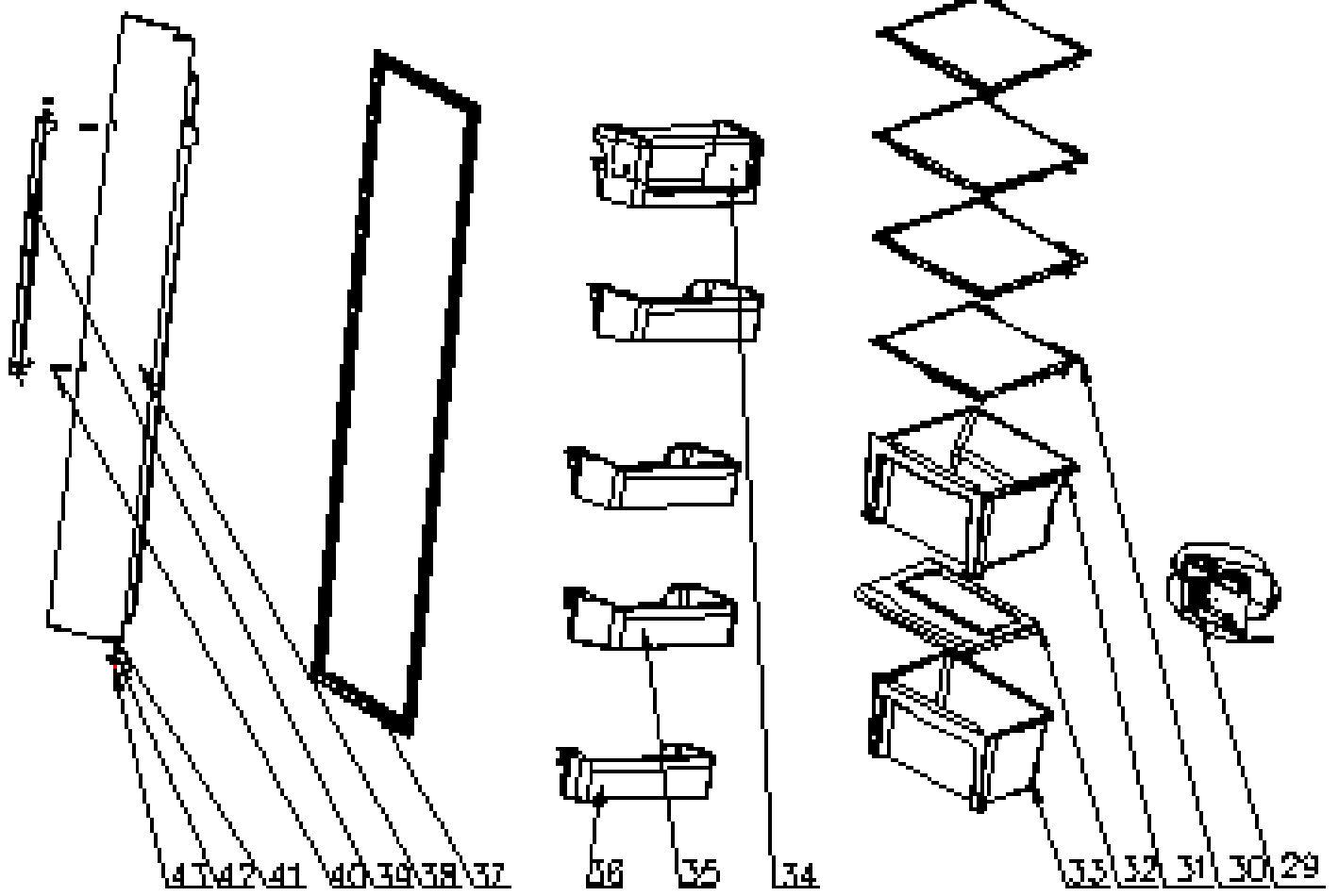

56 57 58 59 60 61 62 63 64 65 66 67 68 69 70 71 72 73 74 75 76 77 78 79 80 81 82 83

55 54 53 52 51 50 49 48 47 46 45 44

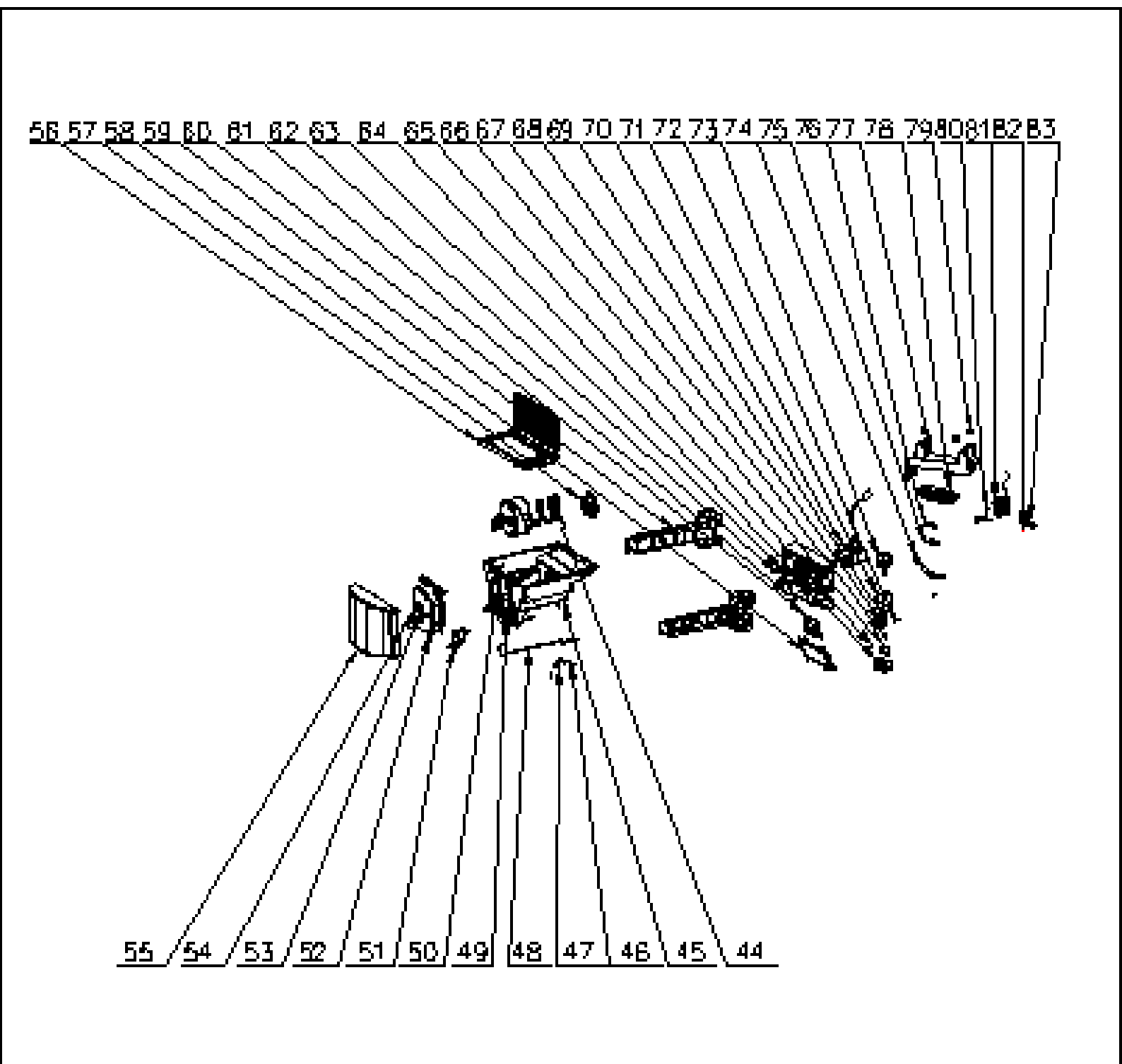

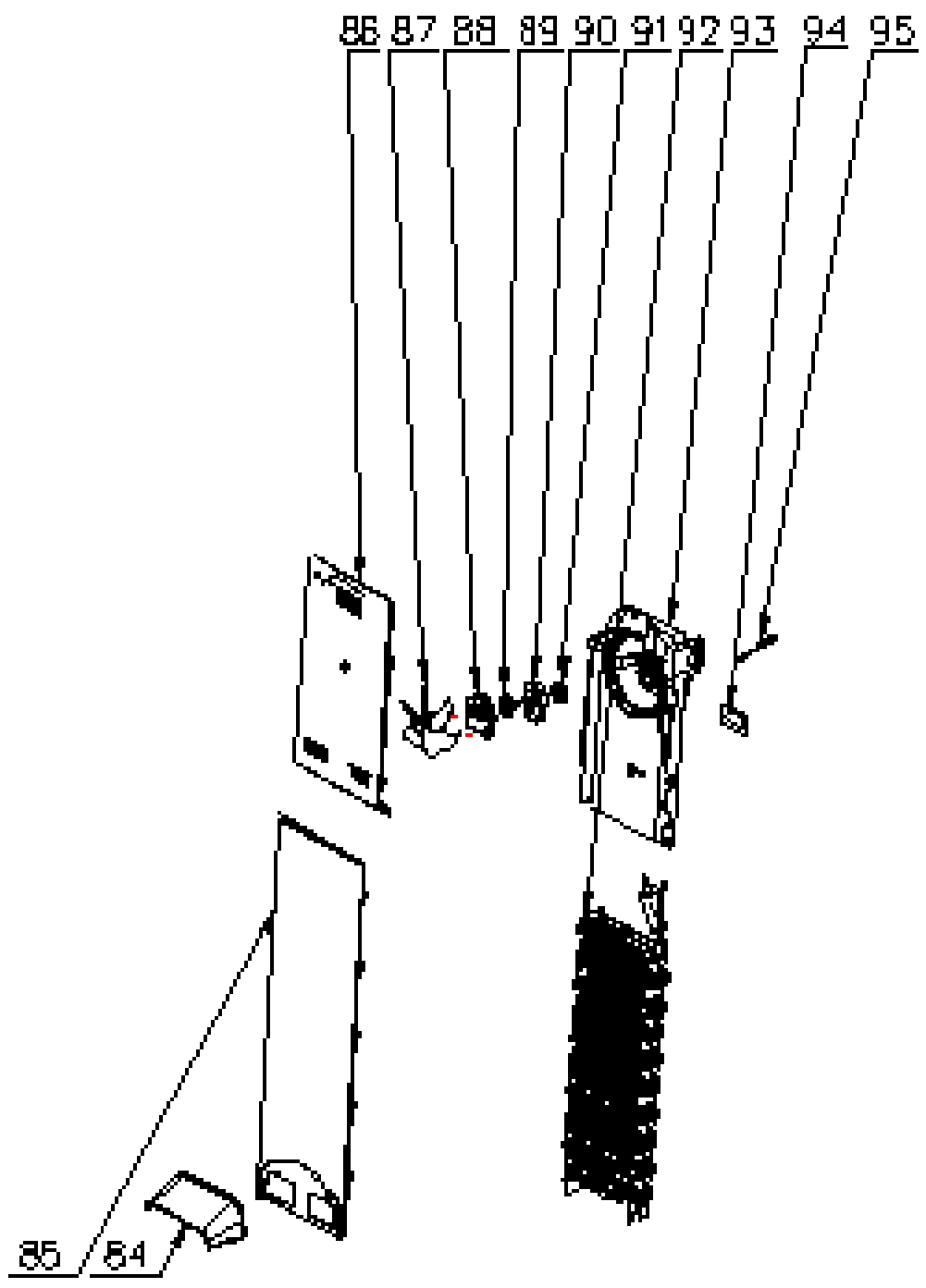

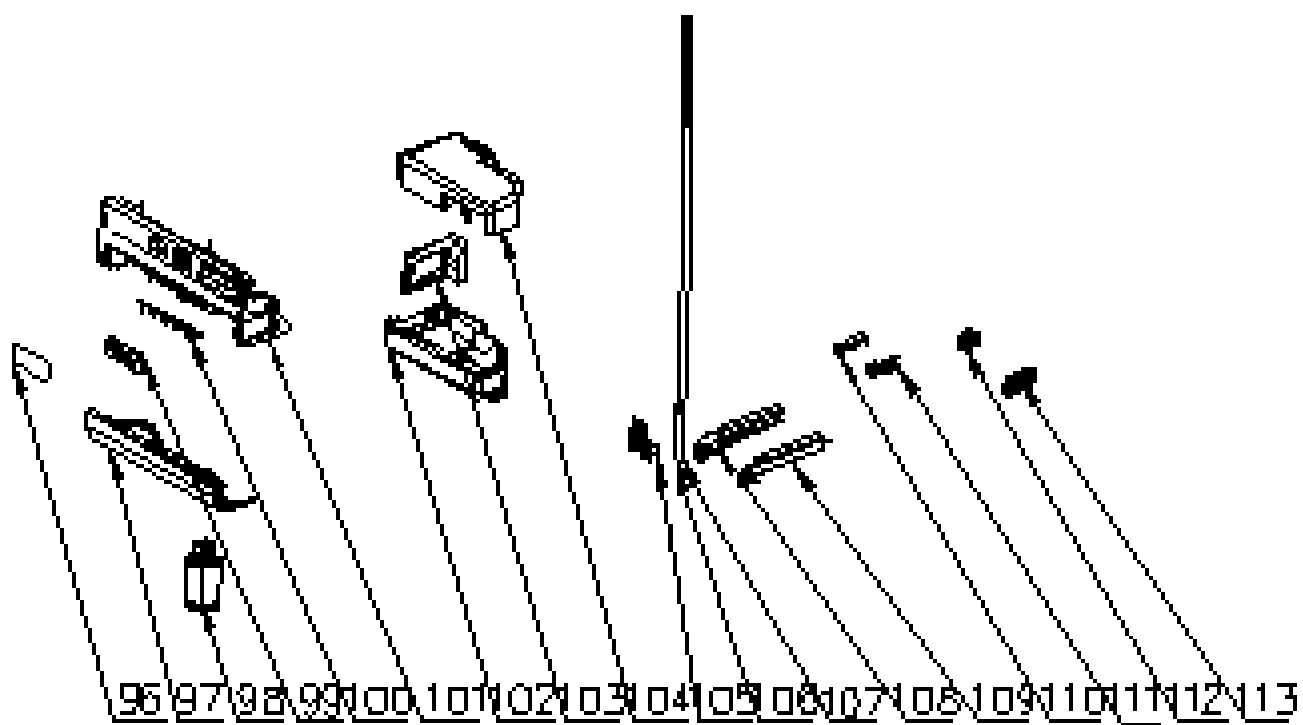

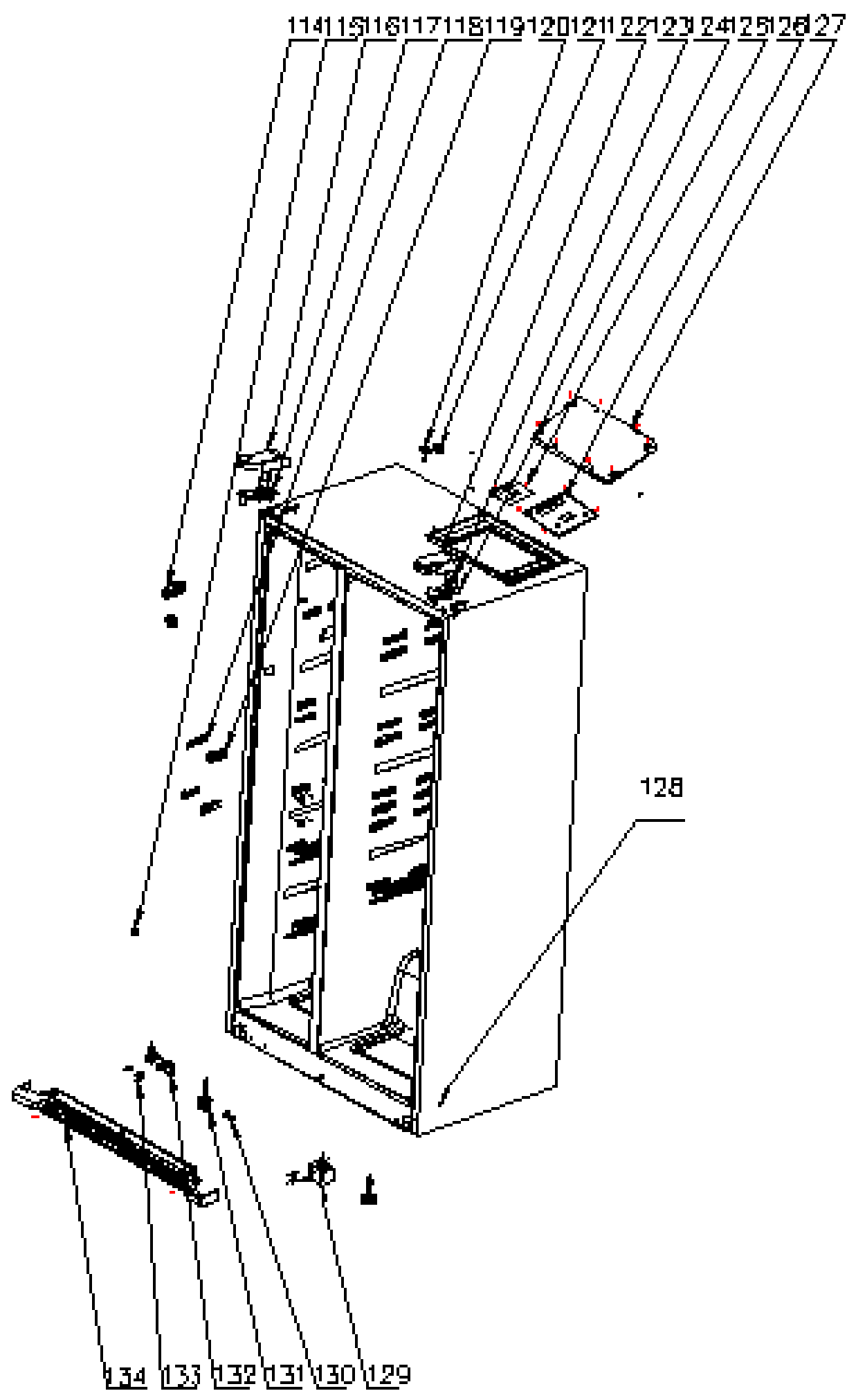

135 136 137 138 139 140 141 142 143

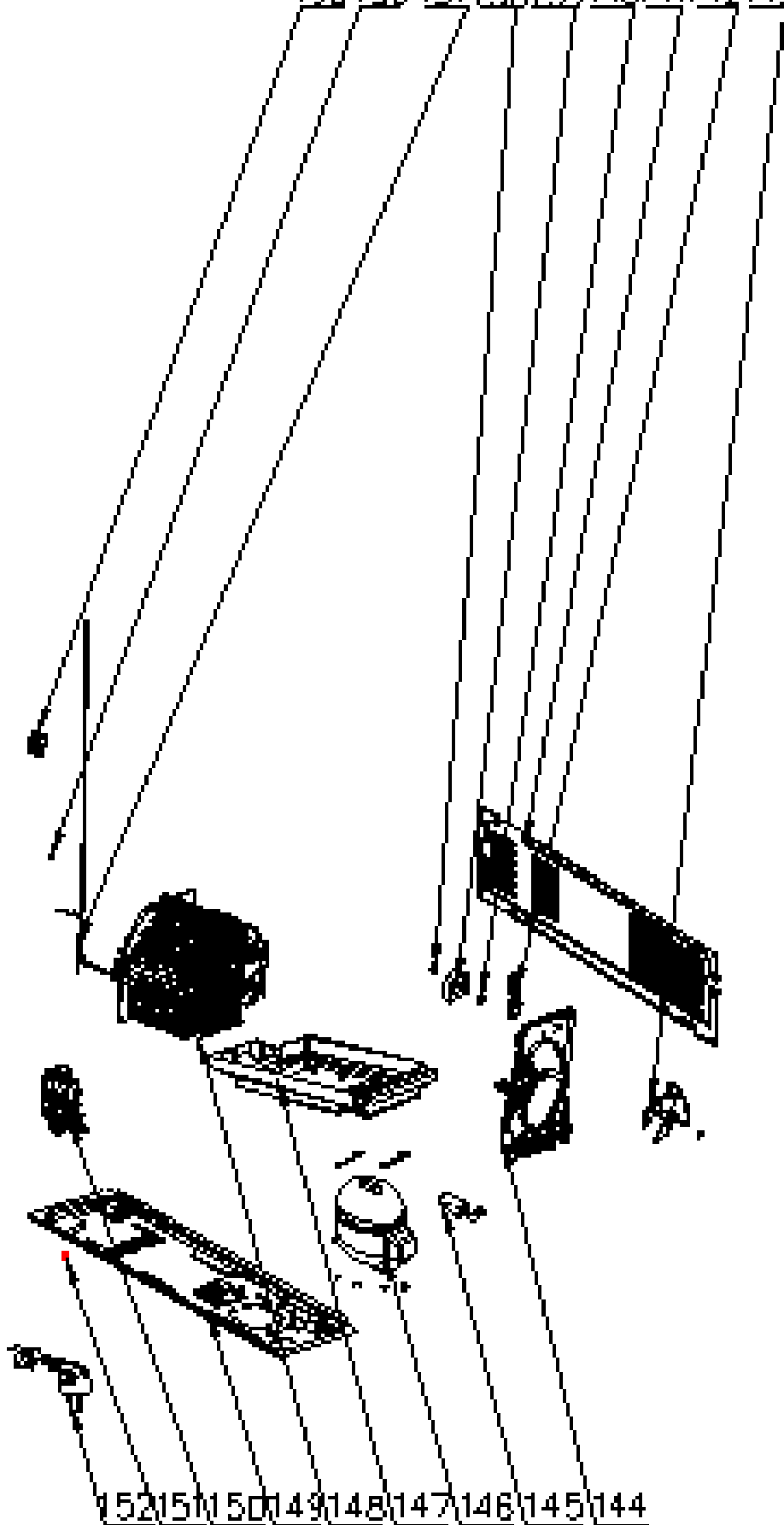



CAFF205SS - Caple Side by side fridge freezer

Item	Part Code	Description	Qty
1	501152810006	display and control panel	1
2	502500100060	screw	4
3	502301000089	display control PCB	1
4	501151510004	ice cover	1
5	501153810042	valve briquette	1
6	502411010002	ice mouth heater	1
7	50210101000N	sponge pad	1
8	502404010004	open door motor	1
9	502799900028	Ice discharging valve cover	1
10	5037001145TB	F door assembly	1
11	501153810009	ice mouth decorative cover	1
12	501152810002	seal box	1
13	50220201001A	seal foam	1
14	501152810001	seal cover	1
15	50115501000J	F door seal	1
16	500755310001	door stopper	1
17	502410010002	distributor lamp	1
18	50115281000A	lever ice shut	1
19	501151510003	distributor catch	1
20	501253810002	valve compression)	1
21	502502310001	torsion spring	1
22	502408000113	micro switch	1
23	502502100010	washer	1
24	502500300052	screw	3
25	501154510019	F bottom drawer	1
26	501154510020	F upper drawer	1
27	503602010268	F glass shelf assembly	3
28	50115121000B	F tray	4
29	50115281001F	water box	1
30	503602010270	R glass shelf assembly	4
31	501154510018	R drawer	1
32	501154510030	R bottom drawer cover	1
33	501154510017	R drawer	1
34	501151210006	R upper flip tray assembly	1
35	501151210009	R middle large tray	3
36	501151210007	R bottom large tray	1
37	50115501000H	R door seal	1
38	503700113890	R door assembly	1
39	502908010012	R door handle	2
40	502501100012	bolt	4
41	501155810017	door closer	2
42	500755310001	door stopper	1
43	502500300052	screw	2
44	502419010001	Helix assembly	1



CAFF205SS - Caple Side by side fridge freezer

Item	Part Code	Description	Qty
45	50115281000E	ice box	1
46	502502310002	ice select lever spring	1
47	501153810042	valve briquette	1
48	50125281000E	ice select lever	1
49	502500100007	screw	1
50	502500100056	screw	1
51	50115281000G	ice select door	1
52	50115281000H	blade cover	1
53	50125281000A	gasket plate	1
54	501252810009	fixed snap ring	1
55	50115371A006	bucket cover A	1
56	50115281000Q	bucket cover B	1
57	50115281000N	fixture helix	1
58	501154510011	lamp cover	1
59	50115281000S	ice bucket guide	2
60	502410000102	LED	1
61	502500200068	screw	2
62	50125281000M	helix driver handle	1
63	50115281000R	ice crusher motor cover	1
64	50115281000R	solenoid valve guide hook	1
65	50125281000J	solenoid valve hook fixed pin 1	1
66	50115281000U	solenoid valve hook A	1
67	50115281000V	solenoid valve hook B	1
68	50115281000W	solenoid valve hook C	1
69	502502310003	solenoid valve spring	1
70	502404010003	ice output motor	1
71	502101010008	PE sponge	1
72	50125281000L	solenoid valve hook fixed pin 2	1
73	502416010001	cube valve	1
74	501152810010	ice detect lever	1
75	501152810012	I/M sensor cover	1
76	50220201001H	I/M sensor insulation foam	1
77	50115281000X	I/M frame	1
78	501152810011	ice tray	1
79	501157010126	im hanging button	3
80	502403010018	temperature sensor	1
81	502404010002	motor im	1
82	502500100048	screw	1
83	501152810004	junction box	1
84	50115281000D	F return air duct cover	1
85	501154510024	F bottom air channel cover	1
86	501152810005	F air duct cover	1
87	501154510027	fan blades	1
88	501155310010	motor cover	1
89	502799900039	pad	1
90	502404000150	F fan motor	1
91	502799900038	pad	1
92	501551510001	F evaporator assembly	1



CAFF205SS - Caple Side by side fridge freezer

Item	Part Code	Description	Qty
93	501154510022	air duct cover	1
94	500501210003	F air outlet seal sponge	1
95	502415010005	heater	1
96	501155010002	air duct decoration	1
97	501152810014	R air duct lamp cover	1
98	502417010002	filter assembly	1
100	502410000102	LED	1
101	501154510028	R top air channel panel	1
102	502201000140	R air channel foam	1
103	502404000151	electric throttle	1
104	502201000141	R air channel foam	1
105	502417010005	filter head	1
106	501152810016	flexible tube	1
107	501152810015	flexible tube	1
108	501154510010	drawer left slider	3
109	501154510009	drawer right slider	3
110	501154510008	drawer left stopper	1
111	501154510007	drawer right stopper	1
112	502408000113	door switch	1
113	501125810006	sensor box cover	1
114	501125810006	sensor box cover	1
115	502799910008	pipe cover	1
116	501155610032	left hinge cover	1
117	502905010144	top hinge assembly	1
118	501154510008	drawer left stopper	3
119	501154510007	drawer right stopper	3
120	502799900024	inlet connector	1
121	500753810002	inlet connector cover	1
122	501155610033	right hinge cover	1
123	502500300052	screw	6
124	502905010143	top hinge assembly	1
125	502500200051	screw	4
126	502301000088	main control PCB	1
127	501155810269	main control PCB mounting-box cover	1
128	50370501136B	cabinet assembly foamed	1
129	502905010203	right bottom hinge assembly	1
130	50115281001B	quick fitting	1
131	501155810053	adjustable foot	2
132	502905010210	bottom hinge assembly	1
133	502500300052	screw	9
134	501155610041	bottom cover	1
135	501153810022	pipe cover	1
136	501153810035	pipe clip	12
137	501152810017	flexible tube	1
138	502799900038	pad	1
139	502404000128	condenser fan motor	1
140	502799900039	pad	1
141	500755810007	compressor chamber cover	1



CAFF205SS - Cable Side by side fridge freezer

Item	Part Code	Description	Qty
142	501155310008	fan motor box	1
143	501160010001	fan blades	1
144	501155310006	fan supporter	1
145	502421000005	EMI filter	1
146	501402610005	compressor	1
147	501155810066	evaporator tray	1
148	501755810001	rotation finned condenser	1
149	500754510001	compressor mounting panel assembly	1
150	502417010007	water valve	1
151	502500100048	screw	47
152	50240101001K	power cable	1
--	17431000000250	Suppressor	1

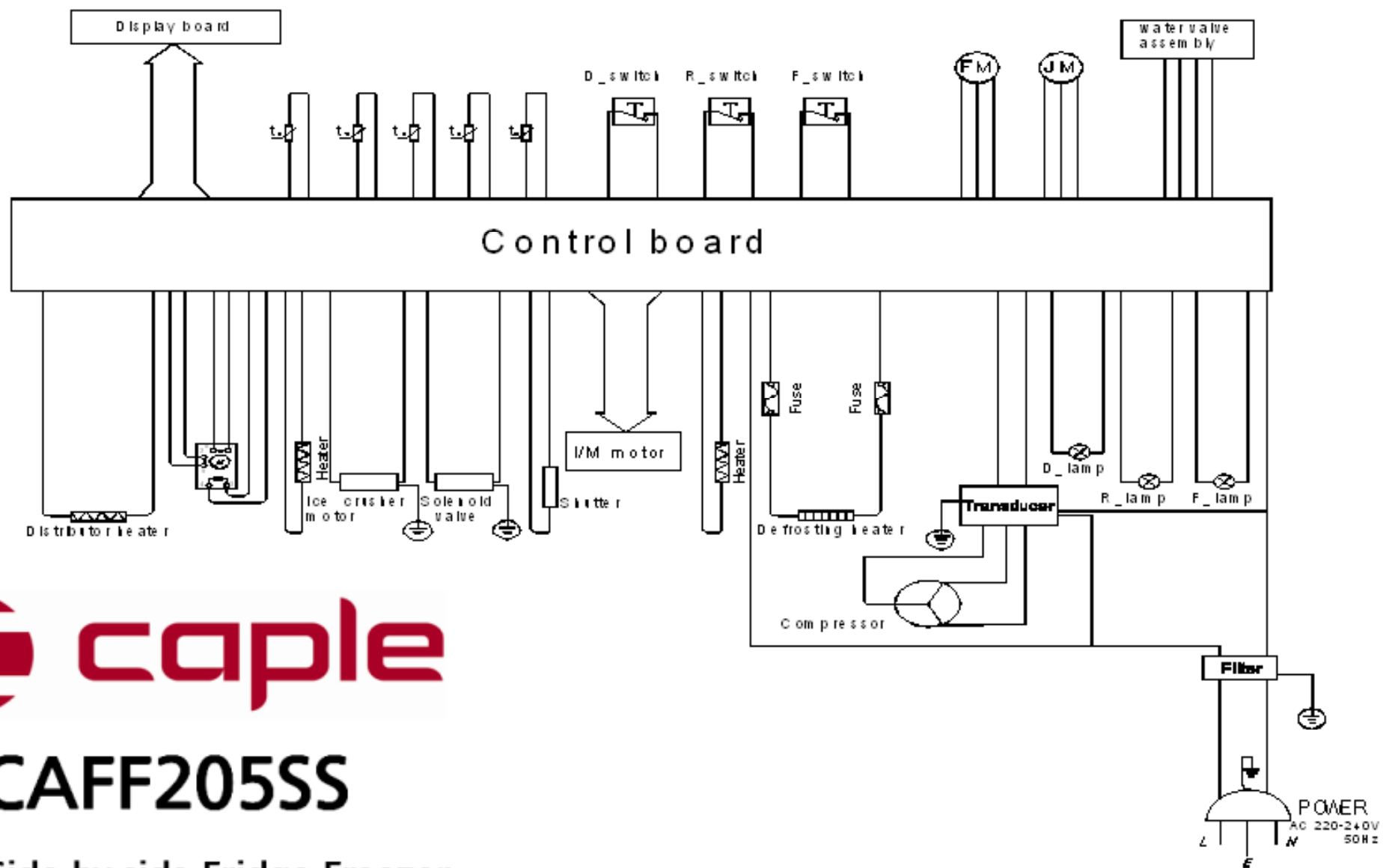

CAFF205SS

Caple Side by side Fridge Freezer

Refrigerator

Service Manual

Model: Caple CAFF205**

Features

- **Energy efficiency**
- **Micro foam technology**
- **Low noise operation**
- **Thick insulation for energy efficiency**
- **Latest No. 2 micro-biological technology**

CONTENT

	Page
Specifications.....	3
Function Schedule.....	4
System Flow Chart.....	5
Circuit Diagram.....	6
Flow Charts:	
No cooling	7
The compressor does not stop	8
Cooling capacity is insufficient.....	9
The compressor does not work.....	10
Maintenance Service and Trouble Shooting.....	11-27

Specifications

MODEL	CAPLE CAFF205**
CAPACITY (L)	515
COLOUR	
POWER SUPPLY (V/Hz)	220-240V/50HZ
RATED INPUT POWER (W)	118
POWER CONSUMPTION (kw-H/y)	427
NET WEIGHT (KG)	106
GROSS WEIGHT (KG)	116
UNIT DIMENSION (D*W*H) – (MM)	902x750x1760
PACKING DIMENSION (D*W*H) – (MM)	963x778x1855
CONTAINER QUANTITY 40'HQ (PCS)	48

Function Schedule

- **Energy Efficiency**
- **Micro Foam Technology**
- **Low Noise Operation**
- **Thick Insulation for Energy Efficiency**

System Flow Chart

1 – Schematic diagram of System Flow Chart

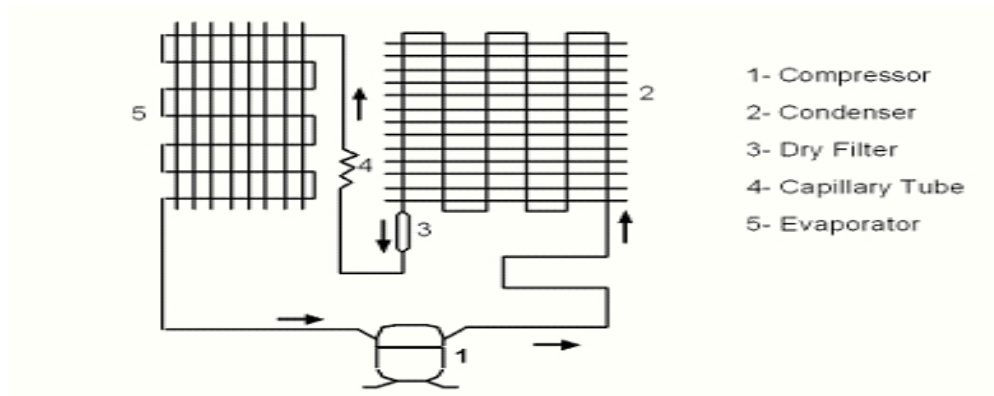

2 – Brief description of System Flow Chart

Model CAFF205 is a direct cooling single-system refrigerator. When the refrigerator is just powered on, the refrigerant flows in the sequence: 1>2>3>4>5>1

Circuit Diagram

1 – Schematic Circuit Diagram

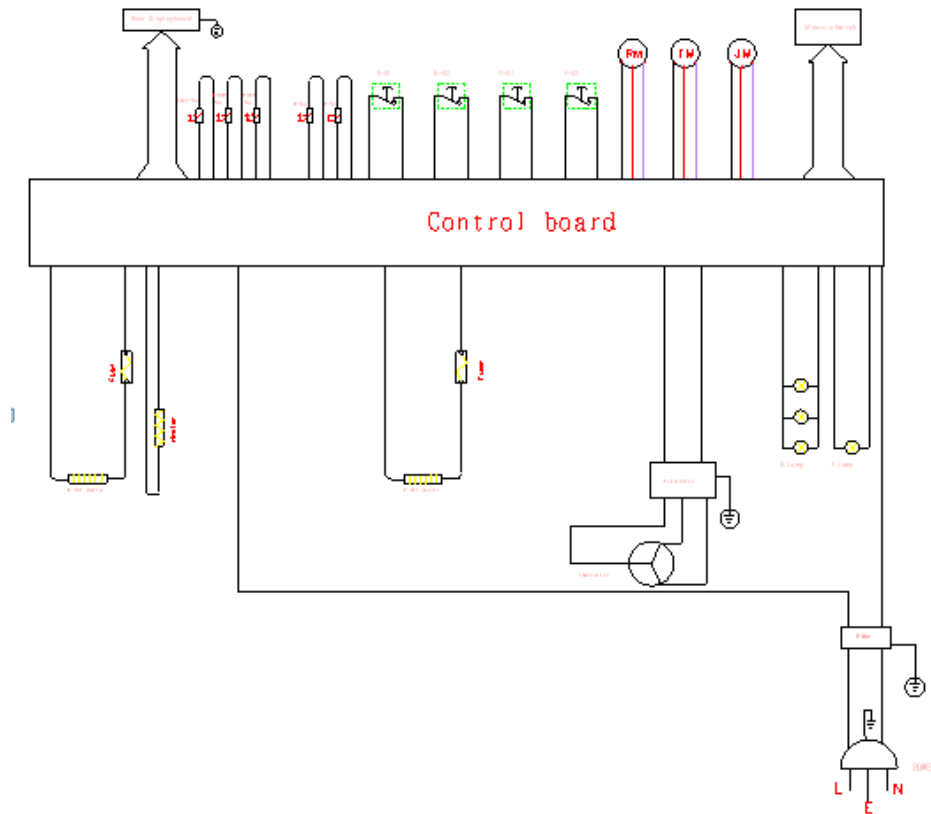

Brief description of Control Principle

Model CAFF205 is a direct cooling single-system freezer.

Maintenance Service and Trouble Shooting

1 – No Cooling

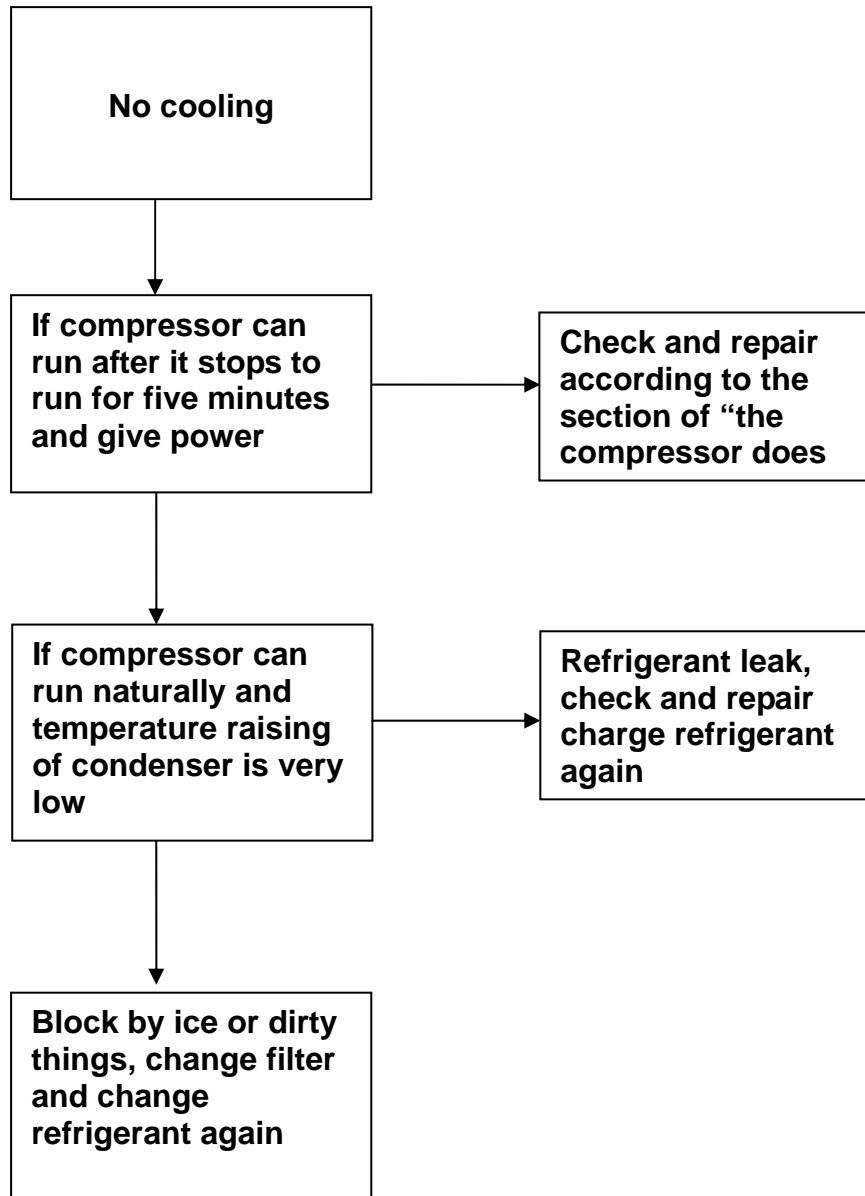

When charging refrigerant we must notice to make refrigerant true.

The Compressor does not Stop

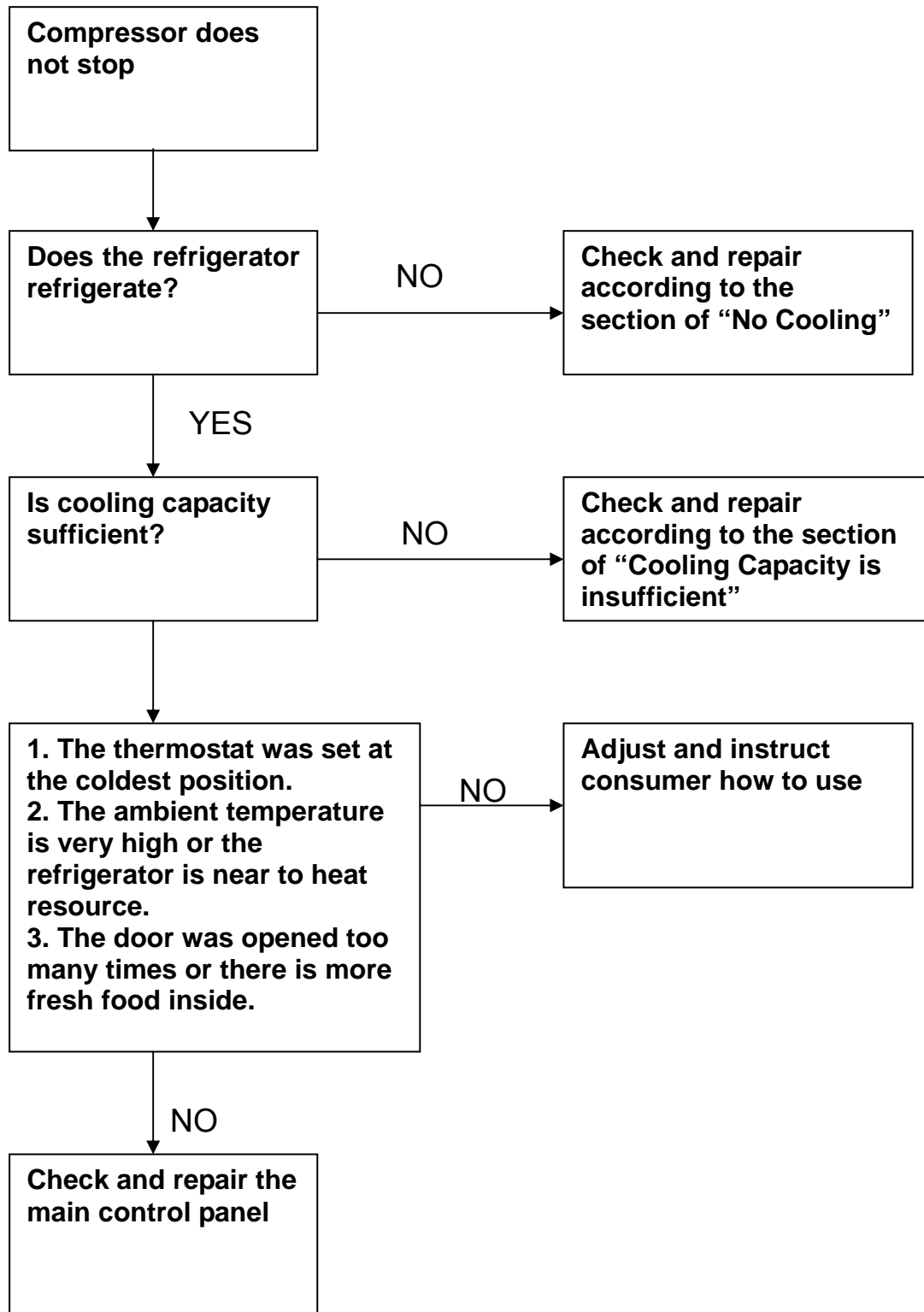

Cooling capacity is insufficient

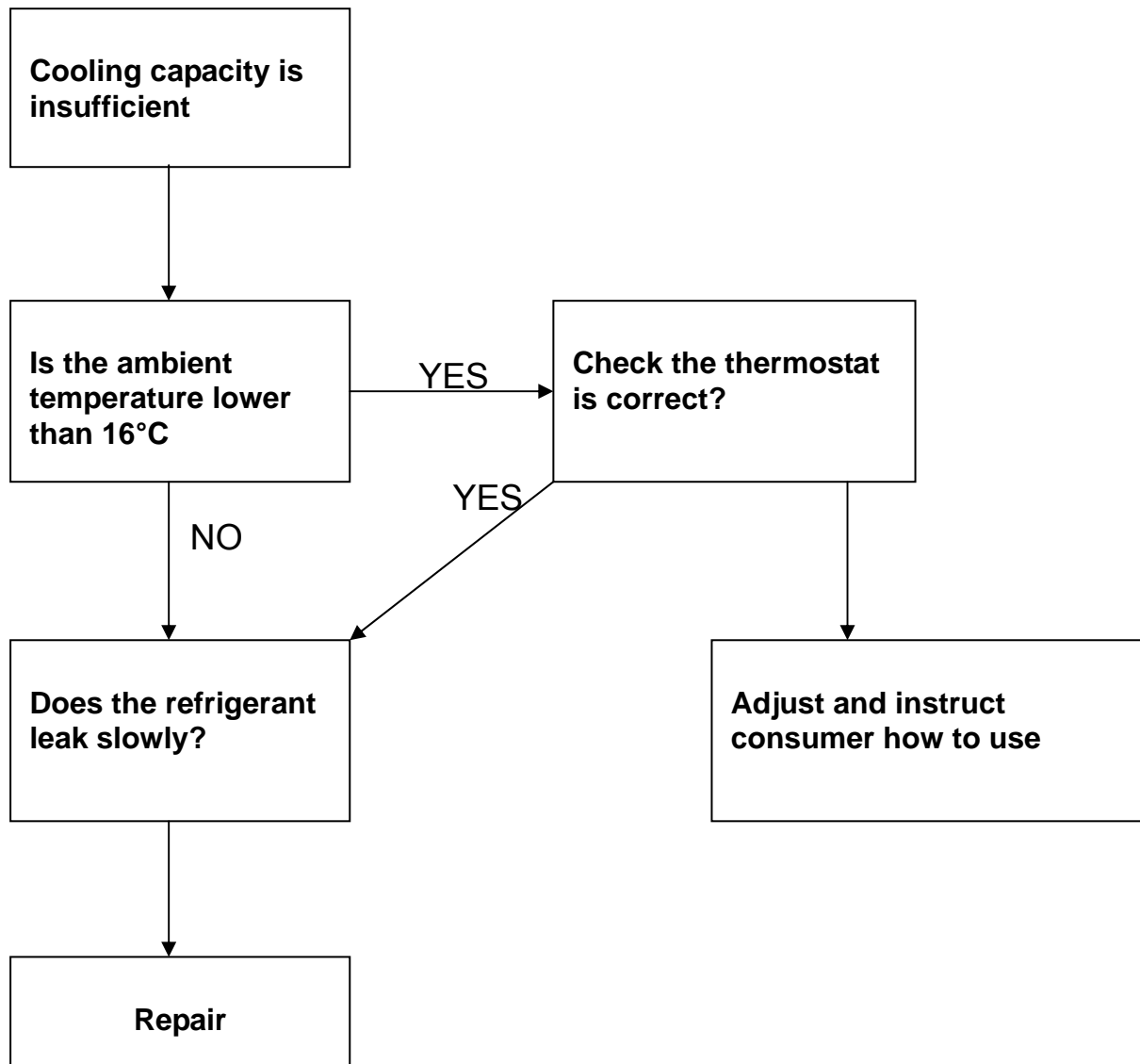

The compressor does not work

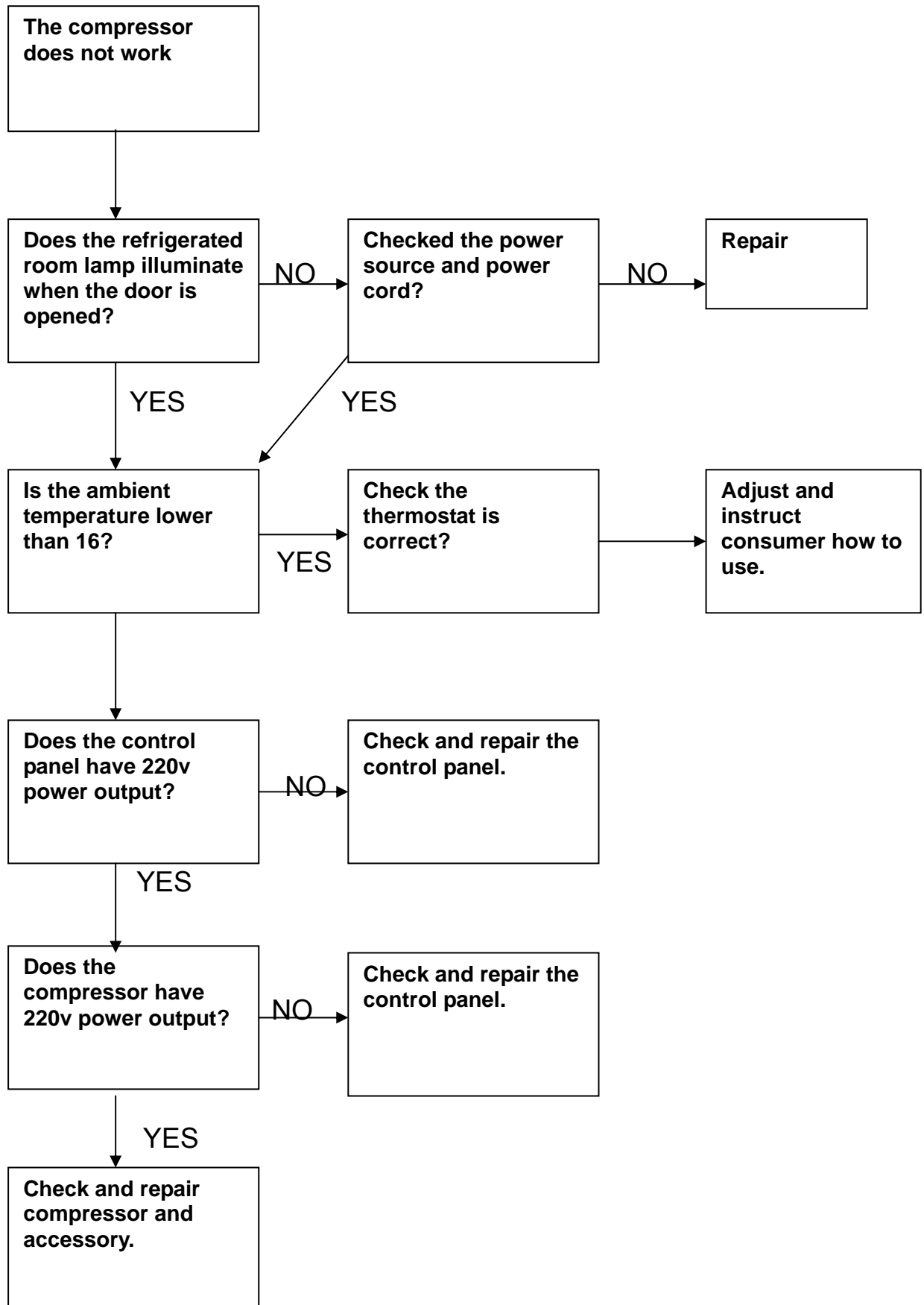

Maintenance Service and Trouble Shooting

5 – Normal Phenomena, not troubles for refrigerators.

In a domestic refrigerator there is not only a complicated electric control system but also a refrigerating system that is difficult to discern whether it is in good working condition. Both the systems are related and affect each other. If a certain part of a refrigerator works abnormally, its refrigerating efficiency will decrease, operation properties will become unstable or even it cannot be used normally for those serious cases.

Refrigerators are generally of larger volume. Once troubles appear, to send them to a service department is really a tough thing. If such is the case the user will always be in suspense. Sometimes, normal phenomena will be erroneously regarded as trouble, therefore before we deal with the topics of frequently occurring troubles of refrigerators and their remedies, we should firstly give a brief account of some normal phenomena which are not troubles. In case any one of such phenomena occurs there is no need to worry about it and the user can use it at total ease.

1. When the compressor of a refrigerator has just stopped running a rumbling sound can be heard from inside its evaporator. This is a sound caused by the flowing of refrigerant in the evaporator tubing; because the pressure difference is still greater after the compressor has just stopped running the refrigerant will flow for a certain time therefore this sound is a normal phenomenon.
2. A click sound can often be heard from the refrigerator. This is a normal sound produced by the pull-in or release of the armature of a current deadweight start relay when starting the compressor. The compressor motor will produce a slight and uniform sound while it is running. This sound is not easy to be heard in the daytime, but of course it can be heard distinctly at night.
3. The compressor consists of an electric motor and a compressing apparatus. During its normal operation, the motor's stator core and winding will rise to a temperature in the range of 100°- 110°C and the temperature of the piston and cylinder of the compressing mechanism can also reach as above 100°C due to the heat produced when compressing refrigerant. Most of the heat radiates to the air through the compressor casing, therefore its casing is generally at a temperature between 85°- 90°C, it is very hot particularly in the summer when the ambient temperature is higher. All these are normal phenomena.
4. For the direct cooling refrigerator a kind of irregular crack sound can often be heard when the compressor is running for a certain period of time, or has just stopped running. The sound is caused by the stress relief due to expansion and contraction when temperature changes and

will not affect the normal application of the refrigerator.

6 – Common Troubles in Refrigerators and their Remedies.

Causes for troubles occurring in refrigerators are closely related to the quality of components and workmanship in assembling by manufacturers as to whether refrigerators are properly used and maintained. The parameters generally used to express the working conditions of a refrigerator include the temperature inside the refrigerator, operation rate, electric power consumption, noise level and other functional indexes. If any one of these parameters is beyond its permissible range this indicates that there is a fault or trouble in the refrigerator.

During the whole service life of a refrigerator the probability of troubles occurring within a unit time is called its failure rate. Making a comparison between the control circuitry system of a refrigerator and its refrigerating system we can find that the failure rate of the former is higher and that of the thermostat is the highest. In troubleshooting the first thing you must do is to determine where the trouble comes from – the control system of the refrigerating system. There are generally no trouble indicating instruments mounted on the domestic refrigerator. Locations and natures of troubles should be determined according to their respective features, therefore experience in servicing is very important to troubleshooting. Service technicians with rich experience can correctly locate them and take reasonable remedy measures based on their comprehensive analysis of trouble characteristics as well as operating conditions for various kinds of refrigerators.

Three Essentials for Checkup

1) Look

- a) Check the tubing of refrigerating system for cracks and various welding points for leaks. If leakage occurs an oil stain can definitely be seen.
- b) Check the suction and exhaust pressure values (high pressure and low pressure) of compressor to see whether they are normal.
- c) Check the conditions of frost attached to its evaporator and gas return tube. It is abnormal if frost has formed on part of the evaporator or there is no frost attached to it.
- d) Pay attention to the speed of temperature drop inside the freezer compartment. It is abnormal if the speed of temperature drop is obviously slower than the corresponding normal speed.
- e) Check the environment to see whether it is suitable for placing a refrigerator.
- f) Check refrigerator door seal, case, table surface and heat insulation layer.
- g) Look at the main control board to ascertain if various indication states are normal.

2) Listen

- a) Listen to the noises produced when the compressor is running. Hums from a fully enclosed aggregate unit are the sound caused by overload indicating that the motor cannot be started normally, meanwhile a clattering sound can be heard from inside the start relay which is produced because the start contacts cannot be released normally. A whistling sound is caused by the high pressure gas flowing out of the crack of the pressure tube inside the compressor and clunks are the sound of striking after the suspended spring inside the compressor has broken.

During the normal operation of the compressor a slight and uniform hum sound due to undulation of electric current can be heard generally. This is a normal phenomenon. However, if it sounds like “tong, tong”, i.e. and impact sound inside the compressor, this means that a large quantity of wet vapour of refrigerant or refrigerating oil has come into the compressor cylinder. If it sounds like “dang, dang”, a striking sound of metal parts inside the compressor, this means that some moving parts have loosened (note to differentiate this sound from those formed during starting or stopping the compressor).

- b) Listen to the sound caused by the flowing of gas in the evaporator. Open the refrigerator door while the compressor is in operation, incline your ear and listen attentively to the gas flow sound inside the evaporator. If it sounds like gently whistling accompanied by a sound similar to water flowing, this is the sound produced by the normal circulation of refrigerant within the evaporator. In case only the gas flowing sound can be heard and there is no water flowing sound, this indicates the refrigerant has already percolated. If neither the flowing sound nor the gas sounds from the evaporator can be heard this means that the filter or capillary has been clogged.

3) Touch and Feel

- a) Feel the compressor when running. Its temperature should be generally less than 90°C in the normal state (it may exceed 90°C in case of running for a longer period of time).
- b) After the compressor has operated normally for 5-10 minutes, touch and feel the condenser. The temperature of its upper part should be higher than that of its lower part (or its right part is hotter than its left part depending on the type of condenser coil). This indicates that the refrigerant is circulating. If the condenser is not hot this means a leakage of refrigerant. In case the condenser radiates heat for only several minutes and then cools down this means that the filter and capillary have been clogged. As for the forced air cooling condenser hot air will be blown out of it. This means that the system is out of order.
- c) Feel the filter's temperature. During the normal operation of the refrigerating system the temperature on the filter's surface should be a little higher than the ambient temperature. If you touch it with your

hand you will have a sense of slight heat. If dew condensation appears due to the temperature being obviously lower than the ambient temperature, it means that most meshes of its screen have been clogged resulting in an obstructed flowing of refrigerant thus causing a drop in temperature due to throttling.

- d) Feel the temperature of exhaust gas from the refrigerating system. The exhaust gas should be very hot and this is the normal working state. For those refrigerators with an enclosed type of compressor refrigerating system, no frost or dew drop will form on the gas suction tube, otherwise there is something wrong in the system (frosting and dew condensation may appear for a very short time period when just starting the machine. This is a normal phenomenon).

Because a refrigerator is a combination of several components they are related and have influence on each other. In case an abnormal phenomenon has been found through the above-mentioned check ups you need not make a hasty conclusion based on only one abnormal phenomenon. It is advisable to find out two or more abnormal phenomenon, or conduct troubleshooting comprehensively with the aid of instruments, or other ways because several kinds of trouble may share a common abnormal phenomenon. Two or more abnormal phenomena may occur simultaneously due to a certain trouble. With this method you can reject some suspicious trouble and finally make a correct judgment.

7) Analysis of Trouble and Troubleshooting – Poor Refrigerating Effect.

The so-called “poor refrigerating” effect refers to the fact the refrigerator can operate and refrigerate normally but the temperature in the refrigerator cannot drop to the prescribed value under the stipulated working conditions. In view of this, there are many causes for this phenomenon. We are going to discuss and analyse it in the following seven aspects:

1. Leakage of refrigerant Analysis of Trouble

The leakage of refrigerant in the system will result in an insufficient refrigerating capacity. The resulting phenomena are its lower gas suction pressure and exhaust pressure as well as higher exhaust gas temperature. The exhaust tube feels rather hot, a continuous gas flowing sound louder than usual can be heard at the outlet of the capillary and no frost or a smaller quantity of loose frost appears on the evaporator. After shut down the balance pressure in the system is usually lower than the saturation pressure corresponding to the same ambient temperature.

Remedy

In case there is leakage of refrigerant from the system do not hurry to recharge it with refrigerant. Manage to find out leak points immediately and make a note from where it leaks – welding points and parts. After having them repaired recharge refrigerant.

There are so many joints and sealed surfaces in a refrigerator accordingly quite a lot of potential leak points exist in the system. In troubleshooting pay attention to those parts that are liable to leak, check main connection points for oil seepage and tubing for cracks. If there is no severe leak point charge the system with nitrogen and detect leak points with the commonly adopted method, repair them, evacuate, charge the system with refrigerant and then turn on the refrigerator to make a test run.

2. Too much refrigerant charged into the system

Analysis of Trouble

- a. In case the amount of refrigerant charged into the system exceeds its nominal capacity the superfluous refrigerant will of course take some space of the evaporator thus reducing its heat-dissipation area, hence the refrigerating efficiency of the system. The abnormal phenomena caused by this reason are as follows: the gas suction and exhaust pressures are generally higher than their respective normal values, the temperature of its condenser is higher and the electric current of the compressor rises, loose frost forms on the evaporator, the refrigerator temperature drops slowly and frost appears on the gas return tube.
- b. In case excessive refrigerant has been charged, the liquid refrigerant that cannot evaporate in the evaporator will return to the compressor, thus a phenomenon of "liquid striking" will occur. The liquid refrigerant evaporates and effervesces as soon as it flows into the refrigerating oil at the bottom of the compressor. If the condition is severe foams will fill all over inside the compressor housing and be sucked by the piston causing damage to the components of the compressor.

Remedy

According to the operating procedure it is mandatory to turn the machine off and several minutes later open the refrigerant charging tube, let the refrigerant escape from it, replace the dry filter, recharge refrigerant after evacuating and then seal the charging port.

3. There is air left in the refrigerating system

Analysis of Trouble

Residual air in the refrigerating system will reduce its refrigerating efficiency. The prominent phenomena are the increase in its gas suction and exhaust pressures (however the gas exhaust pressure will not exceed its rated value) and obvious increase in temperature in the segment from the compressor outlet to the condenser inlet. Because there is air in the system both the gas exhaust pressure and temperature will rise and moreover, the gas flowing sound is intermittent and obviously louder.

Remedy

After shut down for several minutes, open the tubing, evacuate it and then recharge the system with refrigerant.

4. Low Efficiency of Compressor

Analysis of Trouble

Low efficiency of a refrigerating compressor refers to the actual reduction of gas discharge capacity, hence the corresponding reduction of refrigerating capacity under the condition the refrigerant in the system is unchanged. This phenomenon occurs mostly when the compressor has been used for quite a long time, its moving parts have worn to a considerable degree, fit clearance between various parts have increased and sealing property of its gas valve has deteriorated resulting in a decrease in its actual gas discharge capacity.

Methods of Judgement

Measure the high and low pressures with pressure gauges to see whether they are normal. If an abnormal sound comes from the compressor or the temperature of its casing is too high, cut the discharge port open and operate the compressor and feel if there is pressure at the discharge port with your finger (for a normal compressor its discharge port is difficult to be blocked with your finger if you just apply a little effort).

5. Too Thick Frost Layer formed on Evaporator

Analysis of Trouble

If a direct cooling refrigerator is to be used for a prolonged period time be sure to defrost its evaporator regularly. If you fail to do so the frost layer on the evaporator tubing will become thicker and thicker. Heat conduction will be severely affected when the whole tubing is wrapped with a transparent ice layer and finally the temperature in the refrigerator cannot drop down to the prescribed range.

Remedy

Turn the refrigerator off, make preparations for defrosting, open the refrigerator door to let the air come in, or use a fan to speed up air flowing so as to shorten the time needed for defrosting. Never strike the frost layer with any iron tools or wood stick in order to avoid damage to the evaporator tubing.

6. Refrigerating Oil left in Evaporator Tubing

Analysis of Trouble

During the process of refrigerating cycles a little refrigerating oil may remain in the evaporator tubing and after a longer time of operation. If there is considerable refrigerating oil left in the evaporator, the heat conduction effect will be severely affected thus causing a poor refrigerating effect.

Remedy

It is quite difficult to determine whether this trouble is caused by the refrigerating oil left in the evaporator tubing because this kind of phenomenon and other several troubles tend to be confused. Generally speaking you can make a judgement based on the frost formed on the evaporator. If the frost does not cover the evaporator

and moreover it is loosely formed you can make a judgement that the deterioration of refrigerating effect is due to the accumulation of refrigerating oil left in the evaporator tubing, in case no other trouble have been found. To clear off refrigerating oil left in the evaporator, dismantle the evaporator, purge it thoroughly and then dry it. In case it is difficult to dismantle, charge refrigerant from the evaporator inlet to wash it several times then purge and dry it with nitrogen.

7. Flowing Obstructed in Refrigerating System

Analysis of Trouble

Because the refrigerating system was originally not purged thoroughly, some of the filter screenmeshes have been clogged by dirt accumulated in the filter after using it for a certain period of time, thus resulting in a decrease in flow rate and a poorer refrigerating effect.

The abnormal phenomena caused by this kind of slight clogging in the system are as follows: the gas discharge pressure is lower, the temperature of discharged gas drops down, the position clogged has a temperature lower than that in normal conditions and for a severe clogging even dew condensation as frosting may appear.

Remedy

Purge the tubing and after replacing the dry filter with a new one, or clearing it thoroughly, recharge the system with refrigerant and seal the charging port.

8 – Analysis of Troubles and Troubleshooting – No Refrigerating

The phenomenon that the compressor runs normally but no frost (or only a little frost) appears on the evaporator and the refrigerator temperature does not drop down is called “no refrigerating”. There are many causes for this trouble and it is relatively complicated too. In servicing pay special attention to finding direct causes for this phenomenon. Three main potential causes for this trouble are analysed below:

1. All Refrigerant in the System has leaked out

Analysis of Trouble

Leak points in the refrigerating system have not been found and repaired timely thus resulting in the total escape of refrigerant. There are two kinds of leakage:

Slow Leakage – when we want to use a refrigerator that has been put out of use for quite a long time we find the leakage of refrigerant or, in the course of its operation we have found that the refrigerator is gradually becoming not so cold and finally no refrigerating can be achieved.

Fast Leakage – all the refrigerant will escape swiftly due to abrupt rupture of system tubing.

Symptoms of total leakage of refrigerant are mainly as follows: the compressor can be started easily (if there is no damage to the

compressor parts) and its operating current becomes low, its gas suction pressure is high and discharge pressure is lower, the gas discharge tube feels rather cold, no sound of gas eruption from the liquid in the evaporator can be heard and no gush will come out of the process tube if you cut it open after shutdown.

Remedy

Check the whole machine, particularly those locations which are liable to leak. After leak points have been found, repair them or replace them with new parts according to specific circumstances then evacuate the system and finally charge refrigerant.

2. Refrigerating System - clogged with ice

Analysis of Trouble

The dryness treatment for the major parts in the refrigerating system has been performed improperly, the effect of air purging for the whole system is not good, or the water content in the refrigerant is out of standard. All these will cause the expansion valve to be clogged with ice. The symptoms for this trouble are as follows:

The refrigerator can sometimes refrigerate and sometimes cannot.

The refrigerator compartment works normally at the beginning but after working for a certain period of time frosting begins at the clogged position, evaporation temperature reaches below 0°, water will accumulate at the narrow part of the capillary and clog it gradually, then frost begins to melt at the evaporator, no gas flowing sound can be heard and the gas suction pressure assumes a state of vacuum. Note that these phenomena will appear intermittently. Sometimes the refrigerator works well and sometimes not well. In order to determine whether it is clogged with ice, heat the suspicious points with hot water to make ice melt and after a while if a gas flowing sound resulting from an abrupt gush is heard and the gas suction pressure rises as well, it can be confirmed that the trouble is caused by ice clogging.

Remedy

If there is too much moisture in the refrigerating system it is advisable to release the refrigerant, purge the tubing with nitrogen and then charge the system with the filtered refrigerant. However, the commonly adopted method is to connect a filter with moisture absorbers (such as silica-gel and anhydrous calcium chloride) to the refrigerating system so as to filter out the moisture from the system, then replace the filter, evacuate it again and finally charge the system with refrigerant.

3. Refrigerating System - clogged with dirt in the capillary

Analysis of Trouble

The capillary inlet is a place where coarse-grained dirt or refrigerant oil in the system will tend to settle down and clog it. In case considerable dirt accumulates there, the whole filter screen may be blocked totally making the refrigerant unable to go through. Clogging with dirt exhibits the same symptoms as that with ice, namely higher gas suction pressure, lower temperature of discharged gas and no gas flowing

sound from the evaporator. The difference between the both is as follows:

If the clogging is caused by dirt, tapping the suspicious clogged point (generally in the capillary of the connection joint of the filter) may cause the refrigerant to flow through partially resulting in some corresponding change, where as in that case if you heat it with a hot towel no reaction will happen, no flowing sound can be heard and there is no periodic change. After rejecting the possibility of ice clogging it can be generally considered as clogging due to dirt.

Remedy

Dismantle the system, remove the dry filter from it, purge the tubing with nitrogen, install a new filter, then evacuate it and finally charge it with refrigerant.

4. Refrigerating in System – clogging in filter

Analysis of Trouble

Total clogging of a filter rarely occurs. This trouble is mostly caused by the past-like matter formed from the substances filled into the system or other dust after the refrigerator has been used for a long time, or by the dirt accumulated gradually inside the filter. Sometimes, tapping the filter may cause a passage for flowing. Touching it with your hand you will feel that it is cooler compared with its temperature in the normal state.

Remedy

The same as described in the capillary clogging with dirt.

9 - Analysis of Troubles and Troubleshooting - Troubles with Compressor

1. Breakage of gas suction and discharge valve blocks

Analysis of Trouble

The compressor works by means of the opening and closing of gas suction valve and discharge valve to suck and discharge the refrigerant. If the valve block is broken, the refrigerant can not be discharged, hence no refrigerating can be achieved.

Method for making judgment

It is quite difficult to differentiate this trouble from others because they often have similar symptoms. In repairing, firstly listen attentively. If there is some abnormal sound coming from the compressor (sometimes the broken pieces of valve block may stike against the cylinder) and feel the compressor casing with your hand to ascertain whether it is too hot, this is also helpful to the troubleshooting. Secondly, measure the pressures at the high and low pressure ports of the compressor with pressure gauges. If the gas suction valve block is broken, the suction pressure gauge pointer will swing violently and the suction pressure is very high, whereas when the gas discharge valve block is broken, the discharge pressure gauge

pointer will swing drastically and the discharge pressure is very high. In both cases, stop the compressor at once and if technique is available, open the cylinder cover, check up the valve block and repair or replace it with a new one.

2. Sudden Stop of Compressor during its Running

The cause of sudden stop of a compressor during its running is mostly that the gas suction pressure and/or discharge pressure exceed their respective prescribed ranges, thus making a pressure-operated protective relay shut off the power to the compressor and stop it. In the following we discuss mainly the reasons for causing excessively high gas discharge pressure and low suction pressure.

3. Stoppage due to excessively high gas discharge pressure

a) Too much refrigerant charged into the system

Analysis of Trouble

The phenomenon, such as loose frosting and poor refrigerating effect may occur if excessive refrigerant has been charged into the system. Superfluous refrigerant will occupy a certain space of the evaporator, thus reducing its heat dissipating area; the phenomenon of “liquid striking” may occur too. Meanwhile, dew or frost condensation may occur on the gas return tube and the gas discharge pressure will obviously rise. When it reaches the threshold value, the protective relay will actuate and shut off the power supply to the compressor.

Remedy

Open the tubing, re-evacuate and then charge the system with a proper quantity of refrigerant.

b) Air left in the system

Analysis of Trouble

The residual air in the system will circulate together with the refrigerant in the system. The major symptoms caused by this residual air is higher gas discharge pressure, higher discharged gas temperature (the gas discharge tubing is considerably hot when you feel it with your hand) and poorer refrigerating effect. Furthermore, the gas discharge pressure will exceed its normal value when the compressor has run for a period not too long, thus making the protective relay actuate and bring to a stoppage.

Remedy

Check up how the air has been left in the refrigerating system. Generally, there are two possibilities: one is that the air has been sucked into the system when repairing due to carelessness, or it has not been purged out totally when evacuating the system; the other is that there are leak points at the low pressure end of the refrigerating system. Leak points appear mostly in those low temperature parts or assemblies because the evaporation temperature is lower for such low

temperature devices, especially at the low pressure end it is easier for the air that goes into the system. Once it has been ascertained that air does exist in the system, you have to open the tubing, re-evacuate it and then charge it with refrigerant.

2. Stoppage due to electric troubles

a) Thermostat is out of control.

Analysis of Trouble

In case the thermostat does not work in its good order or its temperature sensor has not been installed properly, frequent stoppage is also likely to occur.

Remedy

Try to adjust the temperature sensor's position until the compressor can be started and stopped normally. If this cannot be achieved and the stoppage still occurs repeatedly, it is most likely that the mechanical parts or contacts are out of order. Disassemble the thermostat, make a thorough checkup and repair it.

b) Overload of electric motor.

Analysis of Trouble

Probably too many things have been put into the refrigerator, hence the thermal load exceeds its refrigerating capacity, or in case the power supply voltage drops considerably, the current flowing through the motor will increase drastically making the thermal protector actuate and the fuse blown, hence the motor stops running. If the motor is still running continuously in such a case its winding will be burned out.

Remedy

Reduce the thermal load, pay attention to the variation in the voltage of the power supply.

c) Abnormal thermal protection.

Analysis of Trouble

The compressor current is within its normal range but the thermal protector actuates repeatedly.

Remedy

Replace the thermal protector with a new one.

d) Sudden stoppage due to other causes – Normal Stoppage.

Start and stop of the compressor is generally controlled by a thermostat. When the temperature in the refrigerator reaches its desired value, the thermostat will shut down the compressor automatically. Never take this normal operation as a trouble, care should be taken to differentiate it from other real troubles in servicing.

e) Compressor won't start.

In case the compressor cannot be started, you must find out the origins of this trouble through check up step by step, probably because there are many causes, including those electrical and mechanical.

1. Inspect the power supply to see whether it is connected to the compressor circuit

Analysis of Trouble

In case the compressor cannot be started, this will generally exhibit in the power supply circuit, for instance; power failure, poor contact of switch and blow fuse. Make a comprehensive analysis of these phenomena, find out its real cause and take correct measures to remove this trouble.

Remedy

- a) Check the input power circuit to see whether there is voltage of the power supply, namely the circuit which is connected to the knife switch. This can be determined with an avometer or a test pencil. If a blown fuse is found ascertain and remove its cause, then replace it with a new one of the same specifications.
- b) Check the compressor accessories, including its thermal protector and relay. In case the thermal protector is damaged, the compressor cannot be powered on. If the relay is out of order, the motor will not run and a hum sound can be heard from it after the compressor is turned on. In that case shut it down immediately, otherwise the motor windings will be burned out in case this condition lasts longer.
- c) Check the relay contacts and plugs to see if they are perfect and work reliably. Poor contact may cause the motor to not run or make a humming noise.

2. Check the circuit voltage to see whether it is normal

Analysis of Trouble

If the circuit voltage is obviously lower than its rated value it will be difficult to start the motor and a hum sound can be heard from it.

Remedy

Measure the voltage with a voltmeter, if it is really too low, give directions to the user for buying a stabilizer so as to step up the voltage, thus normal operation can be achieved.

3. Check the thermal relay to see whether its contacts are closed

Analysis of Trouble

The contacts of thermal relay sometimes may be open due to the leakage of temperature sensing agent from the temperature sensor.

Remedy

Remove the relay cover to check up its contacts. If they are open this means that the original setting is not properly set or temperature sensing agent has leaked out of the temperature sensor. Try to turn the adjusting stem of this value in the direction of the lower temperature graduation, then check the contacts to see whether they are closed. If they are still not closed, dismantle the temperature sensing disc and then immerse it into warm water to see whether the contacts actuate, if not it can be preliminarily determined that temperature sensing agent has leaked out and it must be replaced with a new thermostat.

4. Motor trouble and other electric faults

- a) Motor windings have been burned or short-circuited between turns

Analysis of Trouble

When motor windings have been burned or short-circuited between turns, the fuse will be blown repeatedly and the blowout occurs particularly at the instant when you close the knife switch.

Remedy

Check the terminals and the outer casing to see whether they are short-circuited and measure the resistance of each phase with an avometer. If short circuit occurs or the resistance of a certain phase is low, this means that short circuit does exist in the windings and/or between turns and insulation layers have been burned or deteriorated. A megameter can be used in this inspection too. If the insulation resistance is lower than 2 M Ω , this means that the insulation layer has already broken down. If the motor has been burned, repair it or replace it with a new one.

- b) Fault of control relay

Analysis of Trouble

Overheat, burnout or wear of control relay contacts may occur generally. All these will cause poor contact in electricity.

Remedy

Dismantle it to repair or replace it with a new one.

- c) Poor electric contactor in thermostat

Analysis of Trouble

Burnout of contactor and leakage of temperature sensing agent may occur generally.

Remedy

Replace the old with a new one.

- d) Check the terminals for loose connections and electric circuits for other abnormal phenomena.

5. Mechanical faults of compressor

- a) Seizing of shaft

This phenomenon is caused mostly by poor lubrication, such as insufficient quantity of lubricant, clogging in the lubricant oil line or intermittent lubricant oil supply. Dirt and other impurities in the lubricant oil will increase its viscosity and cause the shaft to be seized. Copper plating may also result in seizing of shaft.

- b) Seizing of piston

This is caused by too small fit clearance between the piston and cylinder or expansion due to heat.

Judgement of seizing shaft and piston

After the refrigerator has been powered on, the compressor will not start and run, but a slight hum sound can be heard and several seconds later, thermal protective relay will actuate and make the contacts open. This process will occur repeatedly but the compressor cannot be started.

10 - Compressor will not stop

Sometimes the compressor will run continuously (for several hours or run without end). If the food placed in the refrigerator is not too much, there may be the following two situations:

- i) The refrigerator is very low. This means that the control system is probably out of order.
 - ii) The control system works normally and there is trouble in the refrigerating system or other parts.
1. Temperature is set improperly
 - a) The temperature control knob is set to the “coldest” position. This position is to be used for fast freezing or continuous running, its temperature for power off is too low, therefore the compressor will not stop and the temperature in the refrigerator becomes lower and lower.
 - b) Inspection Method: Check the temperature control knob to see whether it is set in the position “coldest”.
 2. Thermostat is malfunctioning and makes the compressor run continuously.

Analysis of Trouble

When the thermostat does not work normally, it will make the compressor run continuously, hence very low temperature will be achieved in the refrigerator. The fault is generally due to the fact that the contacts of the thermostat cannot be released.

Remedy

Dismantle the thermostat and do a thorough check up. If it does not function replace it with a new one.

3. Evaporation temperature is too high in refrigerating system resulting in lower refrigerating capacity, hence continuous running of compressor.

Analysis of Trouble

Leakage of refrigerant and clogging in a refrigerating system will directly affect its refrigerating capacity. Due to the reduction in its refrigerating capacity, the refrigerator temperature cannot reach its rated value, the thermostat will not work thus the compressor runs continuously. When the evaporation temperature in the system is too high, the temperature sensing agent in the temperature sensor is also hotter, therefore the thermostat is unable to cut off the power supply to the compressor and stop it.

Remedy

If it has been found that the refrigerant in the system is insufficient in quantity recharge it with refrigerant. In case clogging occurs, disassemble the part where it is blocked. If the evaporation temperature is too high settle this problem with an appropriate quantity of refrigerant.

4. No stoppage of compressor due to damaged heat-insulation layer inside case body and/or door seal.

Analysis of Trouble

When the heat-insulation layer inside the case body deteriorates or the door seal closely touches the door frame, the temperature in the refrigerator will rise and make the compressor run continuously.

Remedy

Check the heat-insulation layer for its damaged parts and repair it to improve its heat-insulation property. If the door has deformed or the door seal is not tightly sealed against the case body, repair them respectively.

5. Too much food is placed in the refrigerator or is placed too densely resulting in poor ventilation or poor conditions for temperature sensing, hence no stoppage of the compressor.
6. Too high ambient temperature, poorer ventilation and heat dissipation make the compressor run without stopping.

11 – Electric Leakage of Refrigerator

1. Slight electric leakage
Electric insulation has deteriorated due to being affected with damp thus resulting in slight electric leakage.

2. Serious electric leakage
Refrigerator case has become live due to faults occurred in some electric devices or the erroneous wiring in installing power cord plug or outlet by the user. This is very dangerous.
3. Electric leakage test.
 - a) Slight electric leakage
A tingle sense will be experienced as soon as you touch the metal parts of the refrigerator with your hand. When you test them with a test pencil, its neon lamp will come on. In that case the first thing you need to do is determine whether the ground is perfect. If the grounding is not a problem, turn off the refrigerator immediately then check the insulation of electric circuits with an avometer.
 - b) Serious electric leakage
Never touch the case body of the refrigerator, its door handle or other metal parts with you hand. Test the refrigerator with a test pencil, it will light up intensively. Measure the resistance between the power cord plug and the case body with an avometer; the reading will be zero (0Ω). In the worse case, the fuse will be blown. Check the 3-prong outlet to see whether the live wire and the null line are inversely connected. This makes the ground protection lead-out from the power cord plug being connected to the live wire. Another possibility is that the live wire and null line of the outdoor power supply circuit have been inversely connected accordingly. This makes the null line become a live wire.

12 – Stronger Vibration and Loader Noise

1. Refrigerator placed improperly
 - a) Uneven ground.
Uneven ground will cause the refrigerator to be placed unsteadily causing stronger vibration and noise during its operation.
 - b) Levelling screws are not properly adjusted.
If the levelling screws on the refrigerator legs have not been adjusted properly, vibration and noise will still occur even if the refrigerator has been placed on a level ground.
2. Abnormal noise from the compressor
Three suspended spring inside the compressor case are out of balance and strike against the case, moreover the wear of compressor parts may cause noise sometimes.
3. Resonance of tubing and loosening of parts.
Improper and compact laying of tubes or the loosening of parts may cause vibration and noise.
4. Inspection Method

To find the sources of noise, press the vibration spot with your hand while the refrigerator is in operation and listen attentively to whether the vibration becomes weak or vanishes. If the refrigerator has not been levelly placed, put a level meter on its top table and adjust the levelling screws on its legs. In case noise occurs from the compressor strike different locations on the side surface of its case using a rubber hammer, or hand hammer with a wood block in between, so as to determine whether the suspended springs are out of balance or being seized.

CAFF205 Error Code

Error Code	Corresponding circuit	Code visibility
E1	Fridge chamber temperature detection circuit	Yes
E2	Freezer chamber temperature detection circuit	Yes
E3	Freezer defrosting temperature detection circuit	Yes
E8	Ambient temperature sensor fault	Yes
E0	Icemaker fault	Yes
EE	Ice maker temperature detection circuit	Yes

