



SO209SS

Caple Steam Oven 460mm



Technical information



Caple SO209 (SS & WH) combination steam oven

Features

Stainless steel or white glass
Stainless steel, black-spot feature bar handle
Stainless steel interior
Touch control with LCD display
Electronic clock
Removable 1.54 Litre water tank
Tangential cooling fan
Internal halogen light

Oven features

Energy class A-20%

11 Functions:

- Light
- fan heat
- turbo grill
- grill & fan
- grill
- steam 100°C
- steam 130°C
- steam & fan heat
- steam pulse
- clean
- auto settings

100 preset cooking recipes

Variable steam cooking temperature 40°C to 100°C

2 pre-set steam temperatures (cooking 100°C and reheating 130°C)

Steam cooking pause function

Touch control programmable electronic timer

Audible minute minder

34 Litre capacity

Cooking output

Fan cooking 1500W

Steam cooking 1100W

Grill 1500W

Accessories

1 perforated tray

1 chrome grid

1 stainless steel tray

Optional accessories

6 stainless steel gastro-tubs

Electrical connection

Rated load 3.2kW

Fuse rating 20A

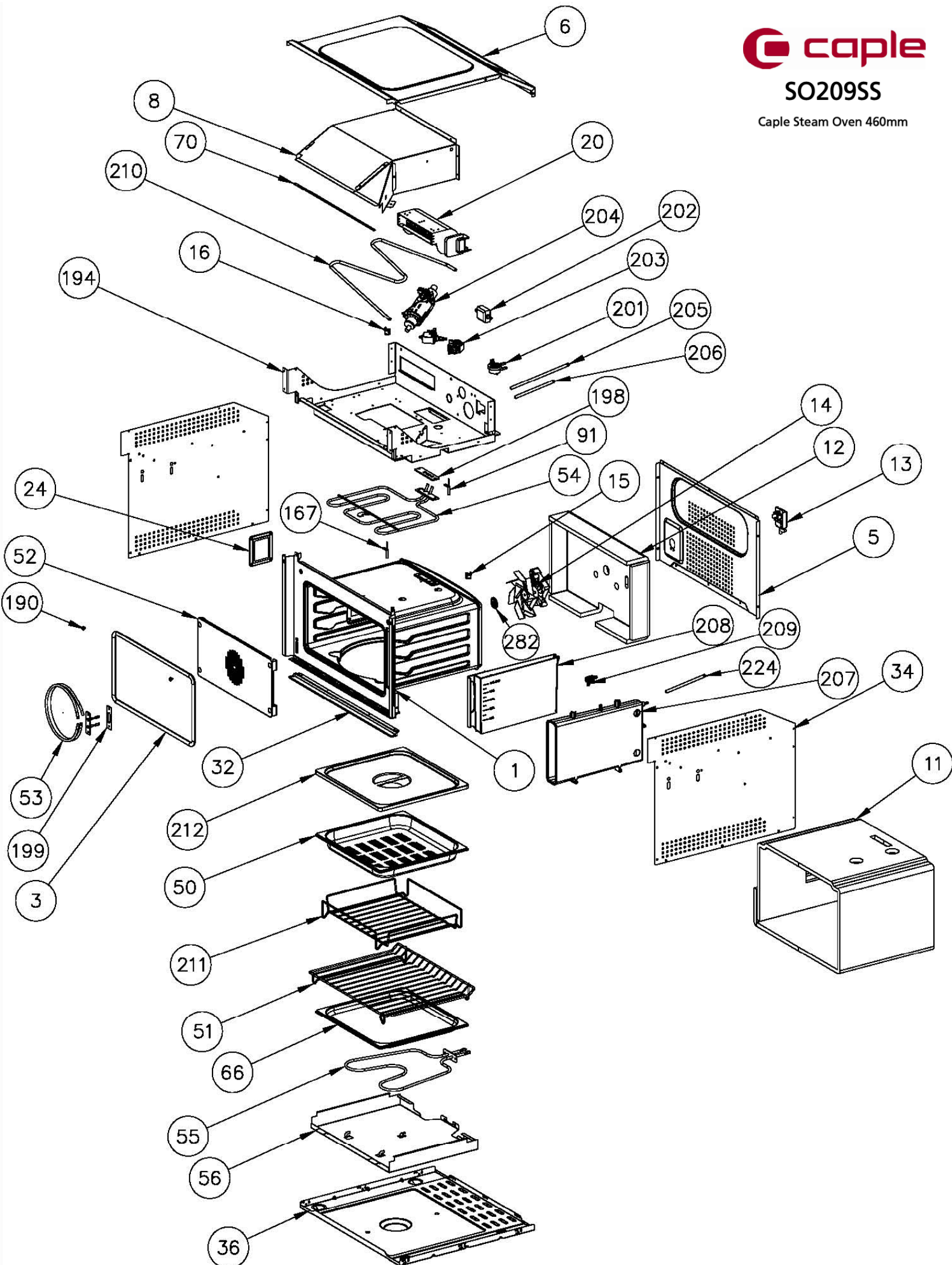



SO209SS

Caple Steam Oven 460mm

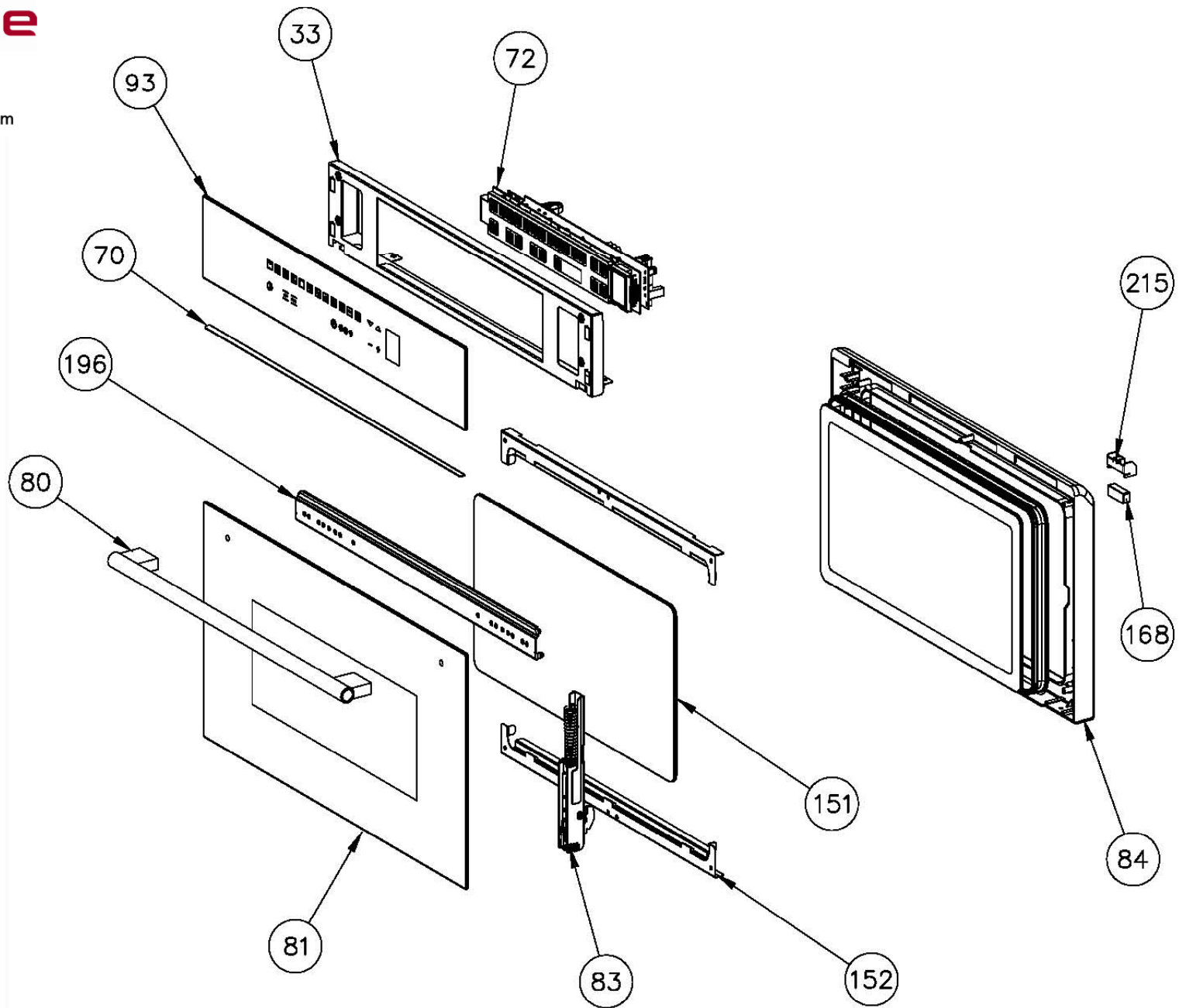



SO209SS - Caple Steam Oven

Item	Part Code	Description
1	42703140	MUFFLE
3	12381190	MUFFLE GASKET
5	12111260	BACK SHIELD
6	12111170	TOP SHIELD
8	12701610	AIR CONVEYOR F45N STEAM
11	12381590	CERAMIC FIBER SHELL
12	12381180	CERAMIC FIBER REAR
13	12530000	TERMINAL BLOCK/FASTEN CABLE 16A
14	12590210	RADIAL FAN
15	12540941	SAFETY THERMOSTAT PRESET T140°C
16	12540945	SAFETY THERMOSTAT PRESET T90°C
20a	12590150	TANGENTIAL COOLING FAN (until 10/07/14)
20b	12590270	TANGENTIAL COOLING FAN (from 11/07/14)
24	12541330	HALOGEN RECTANGULAR LAMP
32	12192671	LOWER PROFILE F45N STEAM BLACK
33	12112531	COUNTER FRONTAL
34	12112400	LEFT-RIGHT SIDE SHIELD
36	12111160	BOTTOM SHIELD
50	12105360	TRAY H40
51	12200470	SHELF
52	12105350	FAN COVER
53	12570200	CIRCULAR HEATING ELEMENT 1500W
54	12570210	GRILL HEATING ELEMENT 1500W
55	12570220	BOTTOM HEATING ELEMENT 300W
56	12193590	FASTENER BOTTOM HEATING ELEMENT
66	12105390	TRAY H20 INOX GN2/3 F45N
70	12380950	ADHESIVE GASKET
72	42782080	INTERACTIVE POWER BOARD STEAM 11F F45N
80	12740600	HANDLE SENSEHAN1 MAURICE LAY
81	42713329	GLASS DOOR
83	12600290	DOOR HINGE
84	42710800	INNER DOOR
91a	12541190	NTC PROBE (until 26/07/15)
91b	12542090	NTC PROBE (from 27/07/15)
93	42715639	FRONTAL GLASS
151	12323500	3rd INNER GLASS THERMO REFLECTIVE
152	12193200	3rd GLASS FIXING PROFILE
167	12540980	MAGNETIC PROXIMITY SENSOR
168	12280320	MAGNET FOR PROXIMITY SENSOR
190	11380640	CAST IRON RUBBER GRILL
194	12112480	COMPONENT SUPPORT
196	12193250	INNER DOOR HANDLE PROFILE
198	12381080	GRILL HEATING ELEMENT GASKET
199	12381090	CIRCULAR HEATING ELEMENT GASKET



SO209SS - Caple Steam Oven

Item	Part Code	Description
201	12541310	DETECTOR WATER FLOW
202	12541320	MAGNETIC ANTI-SCALE
203	42750311	WIRING PUMP + THERMAL PROTECTOR
204	42750292	STEAMER
205	12381160	SILICONE PIPE d.6X2MM
206	12381210	SILICONE PIPE d.10X3MM
207	12381100	TANK HOLDER
208	12381110	TANK
209	12381120	WATER EXIT CONNECTOR L SHAPED
210	12280400	STEAM COOLING COIL
211	12200370	REMOVABLE SHELF FOR GASTRONORM TRAY
212	12105400	STEEL LID FOR GASTRONORM TRAY
215	12192980	FIXING BRACKET FOR MAGNET
224	12381460	SILICONE PIPE d.5X2MM
282	12381570	PARA RUBBER RADIAL STEAM



SO209SS

Caple Steam Oven 460mm



Service Manual

Steam Oven Service Manual

Models SO109 – SO209

*This document has been published to be used for service only.
The contents are subject to change without notice*

CONTENTS

1. SERVICING REQUIREMENTS

1.1 HEALTH & SAFETY

- 1.1.1 Electrical Safety
- 1.1.2 Good Working Practices
- 1.1.3 Insulation Test
- 1.1.4 Sheet Metal Edges

1.2 SPECIAL TOOLS & MATERIALS

- 1.3.1 Tools
- 1.3.2 Necessary Measuring Instrument

2. TECHNICAL OVERVIEW

2.1 OVEN SPECIFICATIONS

- 2.1.1 Oven Weight
- 2.1.2 Power Rating

2.2 SERIAL PLATE

- 2.2.1 Location
- 2.2.2 Model and Serial Number

2.3 COMPONENT SPECIFICATIONS

- 2.3.1 Heating Elements
- 2.3.2 Motors
- 2.3.3 Electric Components

2.4 SYSTEM DESCRIPTION

2.5 TEST PROCEDURE

2.6 FAULT NUMBERS

2.7 OVEN SAFETY FUTURES

- 2.7.1 Child – Safe Locking System
- 2.7.2 Safety Thermostats

2.8 CLEANING PROCEDURE OF STEAM CIRCUIT

4. TROUBLE SHOOTING GUIDE

4.1 ERROR MESSAGE

4.2 OVEN DOESN'T WORK

- 4.3 COOLING FAN PROBLEMS
- 4.4 CONVECTION FAN PROBLEMS
- 4.5 OVEN LIGHT PROBLEMS
- 4.6 DISPLAY PROBLEMS
- 4.7 DOOR HINGES PROBLEMS
- 4.8 BAD COOKING PERFORMANCE
- 4.9 STEAM PROBLEM

7. COMPONENT REPLACEMENT AND ADJUSTMENT PROCEDURE

- 7.1 OVEN REMOVAL
- 7.2 COOLING FAN MOTOR SUBSTITUTION
- 7.3 OVEN DOOR REMOVAL
- 7.4 CONVECTION FAN MOTOR SUBSTITUTION
- 7.5 RING ELEMENT SUBSTITUTION
- 7.6 GRILL ELEMENT SUBSTITUTION
- 7.7 BOTTOM ELEMENT SUBSTITUTION
- 7.8 DOOR GASKET SUBSTITUTION
- 7.9 SAFETY THERMOSTATS SUBSTITUTION
- 7.10 TEMPERATURE PROBE SUBSTITUTION
- 7.11 DOOR HINGES SUBSTITUTION
- 7.12 ELECTRONIC CONTROL BOARD SUBSTITUTION
- 7.13 LIGHT BULB SUBSTITUTION
- 7.14 LOAD & DRAIN PUMP SUBSTITUTION
- 7.15 STEAM GENERATOR SUBSTITUTION
- 7.16 WATER SOFTENER SUBSTITUTION
- 7.17 WATER COUNTER SUBSTITUTION
- 7.18 DOOR SENSOR SUBSTITUTION
- 7.19 DOOR EXTERNAL GLASS SUBSTITUTION
- 7.20 DOOR MIDDLE GLASS SUBSTITUTION
- 7.21 DOOR INTERNAL LABYRINTH GLASS SUBSTITUTION
- 7.22 DOOR INTERNAL LABYRINTH GLASS GASKET SUBSTITUTION
- 7.23 GLASS CONTROL PANEL SUBSTITUTION
- 7.24 DOOR MAGNET SUBSTITUTION

Note: When servicing the oven, health and safety issues must be considered at all times. Specific safety issues are listed below with their appropriate icon. These are illustrated throughout the service information to remind service people of the health and safety issues

1.1.1 **Electrical Safety**



WARNING! TO AVOID ELECTRIC SHOCK!

Do not attempt to service this oven without suitable training and qualifications.

Though it is free from danger in ordinary use, extreme care should be taken during repair.

BEFORE TOUCHING any parts of the oven, always remove the power plug from the outlet.

Ensure the main power has been disconnected before servicing any part of the oven. If the power is required to be on for electrical fault finding, then **extreme** care should be taken not to make contact with electrical components other than with testing probes.

Ensure the oven is turned off when removing any electrical component or connection.

1.1.2 **Good Working Practices**



Ensure the work areas are kept tidy and free of hazards while servicing the oven. On completion of the servicing, ensure the oven and work areas are left clean and tidy.

1.1.3 **Insulation Test**



Megger test to check insulation.

1.1.4 **Sheet Metal Edges**



When working around cut sheet metal edges use appropriate gloves or protection to eliminate the chance of receiving a laceration.

Special Tools & Materials**1.3.1 Tools**

- 7.5V Power Screw / Nut Driver Recommended
- 3" socket extension bar
- 7mm socket
- 10 mm socket
- 12mm socket
- Flexible shaft socket extension
- #1 and #2 Short Phillips Screw driver
- Diagonal pliers
- Long nose pliers
- Flat blade screwdriver
- Vinyl insulation tape
- Polishing cloth

1.3.2 Necessary Measuring Instruments

- TESTER (VOLTS-DC, AC, Ohmmeter)
- Glass thermometer: 100°C or 212°F (1 deg scale)

2.1.1 Oven Weight

lbs /Kg =79/36

2.1.2 Power rating

TECHNICAL DATA

MULTIFUNCTION OVENS	Electrical Ratings and Maximum Connected Load	
	@ 220-240 Volts 50Hz	
	Amperes	Watts
SO109 – SO209	13.9	3200

2.2.1 Location

The product serial number plate is located on the bottom frame.

2.2.2 Model & Serial Number

The numbers printed on the plate contains the following information:



Components Specifications

2.3.1 Heating Elements	Volts	Freq.	Watts	Note
Grill	230	--	1500	
Ring (if present)	230	--	1500	
Bottom	230	--	300	(Temperature limiter 240V 10A T250)
Boiler heating element	230		800	

2.3.2 Motors	Volts	Freq.	Watts	Note
Convection Fan	220-240	50/60	22	CL H
Cooling Fan	220-240	50/60	30	CL H
Pump for 50Hz	230-240	50	21	CL 155
Pump for 60Hz	220	60	17	CL F



2.3.3 Electric Components	Volts	A	Watts	Note
Lamp	230	--	25	
Pump self resetting thermal-cutout	250	--	--	T175
Safety Thermostats	250	16	--	T 250
Water flow sensor	4.5÷24 Vdc	Max 20mA	--	T 65

- **ELECTRONIC CONTROL.** The control consists of a main power board and Full Touch Keyboard.
- **COOKING MODE & TEMPERATURE SELECTION.** The Multifunction oven is full touch control for the set cooking modes and set temperature.
- **TEMPERATURE SENSOR.** There is one NTC sensor, fixed on the top of the internal cavity.
- **HEATING ELEMENTS.** Several heaters are available in the multifunction steam ovens. They are combined together in different ways, depending on the selected mode, but the maximum power never overtakes 3200W.
 - GRILL ELEMENT 1500W at 230V.
 - RING ELEMENT 1500W at 230V.
 - BOTTOM ELEMENT 300W at 230V.
 - PUMP HEATING ELEMENT 800W at 230V.
- **CONVECTION FAN.** This fan is available in multifunction cavities; it works always at the same speed in all convection modes, dehydrate.
- **COOLING FAN SYSTEM.** A cooling fan keeps the internal parts temperature within acceptable values.
- **OVEN LIGHTS.** Halogen 230V lamp. They turn on when a cooking mode starts.
- **STEAM SYSTEM.** The steam ovens incorporate a steam generator that allows steam to be injected into the oven at the start of the baking process.



Test procedure Steam Oven Control

IMPORTANT: The MANUAL TEST procedure can be activated only after power on.



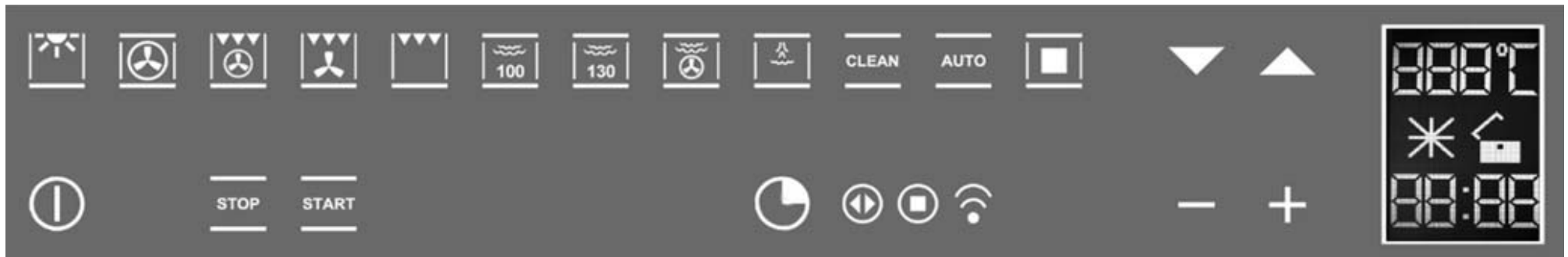

To enter in the MANUAL TEST follow the following procedure:

- a) **NEW CONTROL BOARD (unprogrammed):** When the oven is plugged in to the power the language mode appears to the display Holding simultaneously the  &  the control switch in the Manual Test procedure (its takes about 30 seconds to enter in this mode).
- b) **CONTROL BOARD (programmed):** When the oven is plugged in to the power the DEMO mode appears to the display, PRESS  to exit .



2. Holding the  the control switch in the Manual Operation (**the steam oven have to be completely cold**).
3. Check (by amperometer or wattmeter) the power in the function selected and proceed to the next function until the verifying the change in light of the selected icon.
4. During the steam cooking function the following parameters should be checked:
 - 1) Hold  key (Steam 100): the cooling fan switches ON; Verify immediately the power (1800W)+(50aux);
 - 2) The function have to run for 5 minutes. Check that the function steam is ok and the steam generator works properly.
 - 3) Hold  and proceed with water circuit discharge following the display indication.
 - 4) When this operation ends close the door.

5. During the traditional coking functions the following parameters should be showed:

- 5) Hold  key (ON/OFF)
- 6) Hold  key Ring: preset 165°C; Verify the power (1500W)+(50aux);
- 7) Hold  key Ring + Grill: preset 210°C; Verify the power (3000W)+(50aux);
- 8) Hold  key Convection Grill: preset 165°C; Verify the power (1500W)+(50aux);
- 9) Hold  key Grill: preset MAX°C; Verify the power (1500W)+(50aux);
- 10) Check all function keys.

NOTE: During the manual test the cooling fan operates only in some functions.

Faults

Temperature sensor disconnected or shorted.

Door micro switch open (if present)

Electronic boards over temperature (more than 85°C)

Electronic boards sensor temperature damaged

Flexible key board damaged

Anomaly probe Boiler

Anomaly in the temperature boiler

N°**Err 1****Err 2****Err 3****Err 4****Err 5****Err 6****Err 7**

Oven Safety Features**2.7.1 Child – Safe Locking System**

This feature can be used on the operating mode in the household where a minor is present to prevent children from possibility to change the oven setting. The key function is activated/deactivated by pressing the ON/OFF button for at least 3 seconds. You can activate and deactivate the operating mode of the oven at any time.

2.7.2 Safety Thermostats

This appliance is built with bi-metal mechanical thermostats. The thermostats are mounted in contact with the metal sheet . The function of the safety thermostat is to protect the oven from overheating in the event of a malfunction of the cooling fan. In the event that the temperature is rising over the limits, the thermostat will switch mechanically from off position to on position and all of the heating elements will be cut off from the power. All of the electronics will be still powered. The reset is automatic when the cooling fan was replaced or the cooling fan problem was solved and the temperature is in the right functioning parameters.

Cleaning procedure of Steam Circuit

To enter in the CLEANING PROCEDURE follow the following procedure:

a) Turn on the oven with the key  Select the CLEAN program.

The following screen appears on the display:



b) Using the keys select "STEAM CIRCUIT". At this point, when you select the START key, which is flashing, the program that cleans the inside of the CIRCUIT will start.

You will see

once you have turned it on (if you have already turned it on, its also OK), press START for the second time to start the cleaning cycle.

Several minutes after the start, the oven will have ended the program. A beep will alert you and the following text will be displayed:

INSERT THE
FILL TANK

CLEANING
CYCLE
COMPLETED

OPEN THE
DOOR

With the door open, the beep is blocked.

Afterwards, with the oven off, it will display together with the beep:

**NEED TO
DISCHARGE
WATER
OPEN THE
DOOR**

Open the door and remove the tray:

**REMOVE THE
WATER TANK**

**UNTIL THE
SYMBOL**

After partially extracting the tray (look at the arrow on the left side or the two notches above the carafe), press START to empty the steam production circuit and

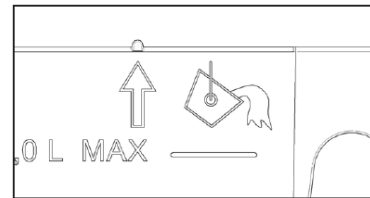

the following text will appear:

UNLOADING

After discharging, the following text appears:

**REMOVE AND
EMPTY THE
TANK**

IMPORTANT NOTE

If the electricity is interrupted during one of the cleaning cycles, when it comes back on, the oven requires you to empty the circuit even though there shouldn't be any water in it. This oven is the only one of its kind that has no need for decalcifying products to keep the steam production systems working properly.

BEFORE TOUCHING any parts of the oven, always remove the power plug from the outlet.

Code	Error	Description	Possible Cause	Corrective Action	section
ERROR 1	Temperature sensor disconnected or shorted.	The control reads out of range values.	Bad connection Temperature sensor broken.	Check the connectors and the harness Replace the sensor	<u>7.10</u>
ERROR 2	Door sensor open	Hardware failure.	Door sensor broken	Replace the door sensor	<u>7.18</u>
ERROR 3	Electronic boards over temperature (more than 85°C)	Overheating of the internal parts.	Cooling fan broken	Replace the cooling fan	<u>7.2</u>
			Bad connections between cooling fan and electronics.	Check connections	--
			Air flow through the cooling channel is not sufficient.	Check proper installation. The slot between the control panel and the door must be free.	--
ERROR 4	Electronic boards sensor temperature damaged	Hardware failure.	Defective cooling fan relay on main power board	Replace the electronic board.	<u>7.12</u>
			Faulty NTC sensor on main power board	Replace the electronic board.	<u>7.12</u>
ERROR 5	Flexible key board damaged	Hardware failure.	--	Replace the electronic board.	<u>7.12</u>

<i>Anomaly</i>	<i>Possible Cause</i>	<i>Corrective Action</i>	<i>section</i>
Oven does not run No power supply	Main breaker or main fuses	Replace the fuses	--
	Short circuit	Find the short circuit and remove it	--
Oven does not run Power supply ok.	Connections to Control Board	Replace Control Board	<u>7.12</u>
		Check the main fuse on Electronic Board	--

Cooling Fan Problems

Anomaly	Possible Cause	Corrective Action	section
Fan does not run No power supply	Control Board relay not switching	Replace Control Board	<u>7.12</u>
Fan does not run Power supply ok.	Blocked rotor	Replace fan	<u>7.2</u>
	Burned coil	Replace fan	<u>7.2</u>
Noisy fan	Lose attachment screws on cooling assembly	Check attachment screws on cooling assembly or replace fan	<u>7.2</u>
The cooling fan is always on	The control is measuring a high temperature inside the cavity	Check all the connections between the sensor and the power board	--
		Check the temperature sensor	--
		Check the power board	--

Convection Fan Problems

<i>Anomaly</i>	<i>Possible Cause</i>	<i>Corrective Action</i>	<i>section</i>
Fan does not run No power supply	Control Board relay not switching	Replace Control Board	<u>7.12</u>
Fan does Not run Power supply ok.	Blocked rotor	Replace fan	<u>7.4</u>
	Burned coil	Replace fan	<u>7.4</u>
Noisy fan	Lose attachment screws on cooling assembly	Check attachment screws Check nut on working fan for tightness or replace it	--

Oven Light Problems

<i>Anomaly</i>	<i>Possible Cause</i>	<i>Corrective Action</i>	<i>section</i>
The Oven lights are always OFF. No power supply.	Control Board relay not switching.	Replace Control Board.	<u>7.12</u>
The Oven lights are always OFF. Power supply is ok.	Lamps are burned out.	Replace lamps.	<u>7.13</u>
The Oven lights are always ON.	Control Board relay has a shorted circuit.	Replace Control Board.	<u>7.12</u>

Anomaly

The display of Control Board is always dark.

Possible Cause

The power supply to the display of Control Board is missing.

Corrective Action

Verify if the voltage is correct on the Control board.
Check the connections and eventually replace the main power board.

section

7.12

Door Hinge Problems

Anomaly

The door does not close or there is not sealing between door and gasket

Possible Cause

Hinges system is broken or damaged

Corrective Action

Replace the units

section

7.11

Bad Cooking Performance

Anomaly	Possible Cause	Corrective Action	section
Bad performance	Heating elements not working	Check the connection of the heating elements	--
		If there is not power on the heating elements check relays on the Control Board. If the Control Board relay not switching replace the units.	<u>7.12</u>
		If there is not power on the heating elements check safety thermostat. If the thermostat not switching replace the units	<u>7.9</u>
		Check the power on the heating elements and replace the elements if needed	<u>7.5</u>
			<u>7.6</u>
			<u>7.7</u>
		Convection fan not working properly	See the convection fan problem
There is not sealing between door and gasket	The hinges system is damaged. Replace the units	<u>7.11</u>	
	The gasket is damaged. Replace it.	<u>7.8</u>	

NOTE: Before servicing perform a cleaning cycle ([see section 2.8](#))

Anomaly	Possible Cause	Corrective Action	section
Steam generator does not make steam. No power supply on heating element	The oven temperature is too high	Wait until the internal temperature drops down below 85/90°	--
	The safety thermostat is damaged	Replace the steam generator	7.15
	Relay on Control Board	Check if the connection of it is ok Replace Control Board	7.12
Steam generator does not make steam. The power supply on heating element is ok	The heating element is damaged	Replace the steam generator	7.15
The steam generator works correctly but there is no steam into the cavity	Tank of water is empty	Fill of water	--
	Pumps do not work properly	Check the pumps function measuring the tension on their contact during Cleaning procedure of Steam Circuit (see section 2.8)	--
	Water softener clogged	Check it, if clogged replace it	7.16
	Water counter damage	Check it, if damaged replace it	7.17



1. Disconnect the power supply cord.
2. Open the door.
3. Remove the screws shown in the pictures.
4. Pull off the oven.
5. Remove the oven by using the lateral handles.

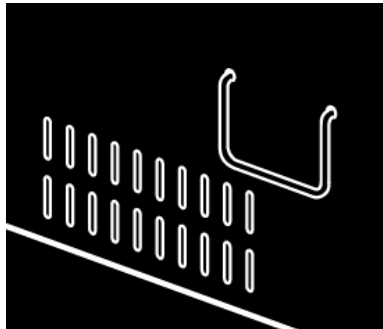

Lateral Handles (if present)



Cooling fan motor substitution

1. Disconnect the power supply cord and remove the Oven from the cabinet.
2. Remove the upper cover.
3. Disconnect the terminals on the fan.
4. Remove the five screws on the fan and remove the fan.
5. Replace the new one with the screws and connect the terminals.
6. The connections must not be loose.
7. Reinstall the Oven into the cabinet.
8. Reconnect the power supply cord after the Oven is installed.
9. Run the Oven and check all functions.

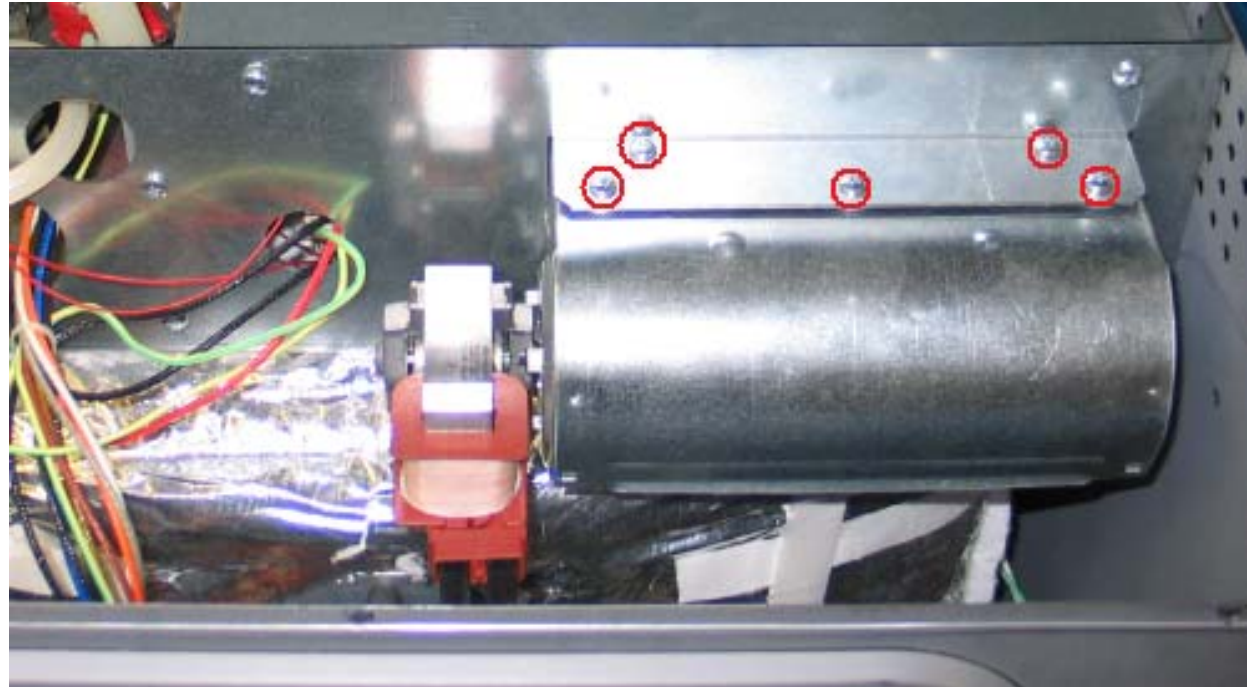

Oven Door Removal**To Remove Door**

1. Open the door completely.
2. Lift up the hinge bracket (1) from the arms (2) .
3. Hold the door firmly on both sides using both hands and close the door, then remove it .
4. Hold firmly; the door is heavy.
5. Place the door in a convenient location.

**To Replace Door**

1. Insert the upper arms (2) of both hinges into the slots. The recesses (3) must hook on the lips (4).
2. Move the hinge brackets (1) back down into position.
3. Close and open the door slowly to assure that it is correctly and securely in place.



Convection fan motor substitution

1. Disconnect the power supply cord and remove the Oven from the cabinet.
2. Remove the upper and rear covers.
3. Remove the internal convection fan cover removing its four screws on the corner.
4. Remove the fan blade by using a 10mm socket (fig.1).or pulling it (fig.2), depending on model.
5. Then disconnect the terminals and remove the fan motor damaged by rotating it as showed in the (fig.3) or removing the three screws (fig.4),depending on model.
6. Mount the new fan motor and then mount also the new fan blade.
7. Connect the terminals.
8. The connections must not be loose.
9. Reinstall the Oven into the cabinet.
10. Reconnect the power supply cord after the Oven is installed.
11. Run the Oven and check all functions.

Note: The internal gasket must be placed correctly, if it is worn replace it with the new one.

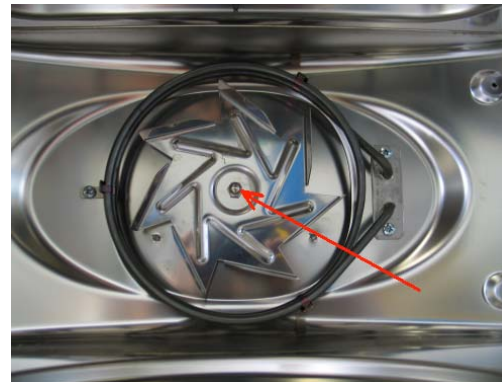

Fig.1



Fig.2

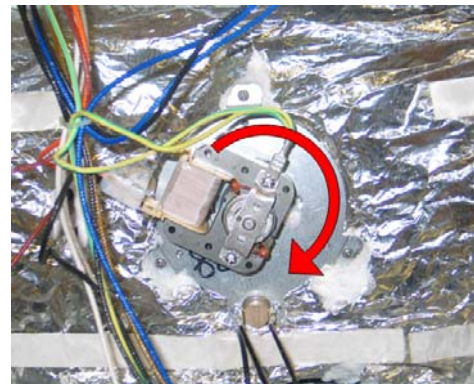

Fig.3

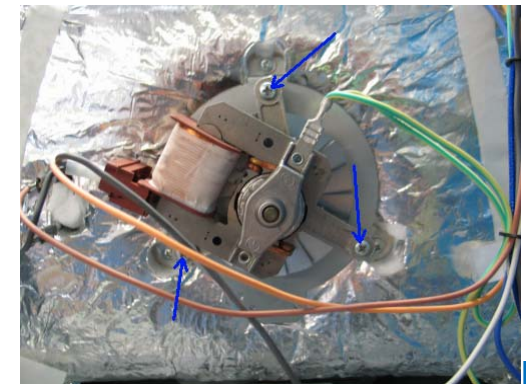

Fig.4

Ring element substitution

1. Disconnect the power supply cord and remove the Oven from the cabinet.
2. Remove the upper, rear covers.
3. Remove the internal convection fan cover removing its four screws on the corner (fig.1).
4. Remove ring element damaged by its screws (fig.2).
5. Disconnect the terminals on the heating element in the rear side.
6. Mount the new ring heating element with the screws.
7. Replace the back support.
8. Connect the terminals.
9. The connections must not be loose.
10. Reinstall the Oven into the cabinet.
11. Reconnect the power supply cord after the Oven is installed.
12. Run the Oven and check all functions.

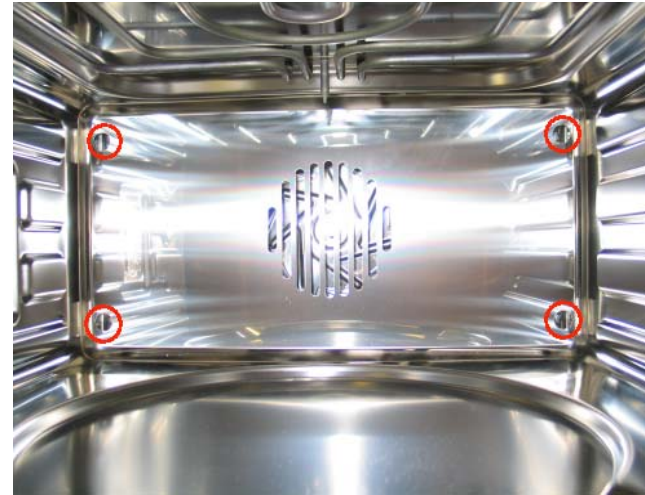

Fig.1

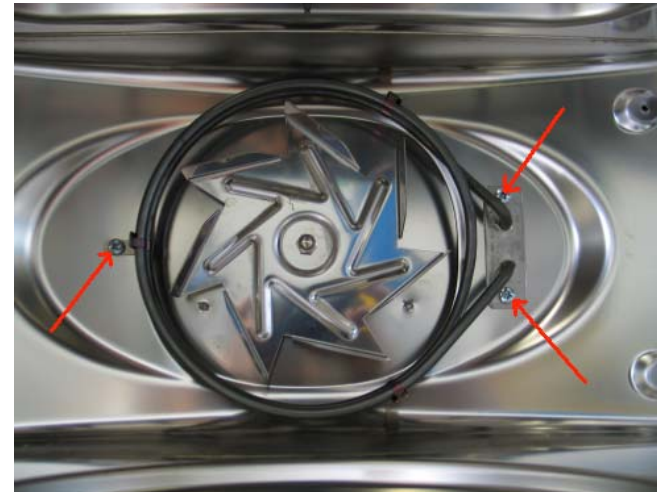

Fig.2

Grill element substitution

1. Disconnect the power supply cord and remove the Oven from the cabinet.
2. Remove the upper cover.
3. Remove the internal component cover (fig 1) by its six screws.
4. Remove the probe from its location using a clamp make rounded the border to extract it. (fig.2).
5. Disconnect the terminals.
6. Unscrew the nuts (fig.2).
7. Than open the door to access to the heating element on the top of the cavity and unscrew the central screw (fig.3) to remove the element damaged.
8. Replace the new one by reversing the previous steps
9. Connect the terminals and insert the temperature probe, crushing the entrance to make oval it to prevent the escape.
10. The connections must not be loose.
11. Reinstall the Oven into the cabinet.
12. Reconnect the power supply cord after the Oven is installed.
13. Run the Oven and check all functions.

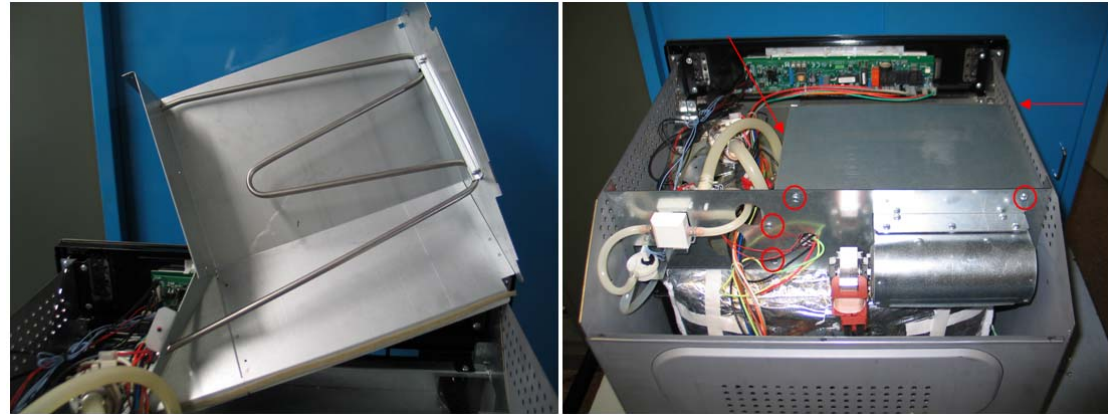

Figure 1

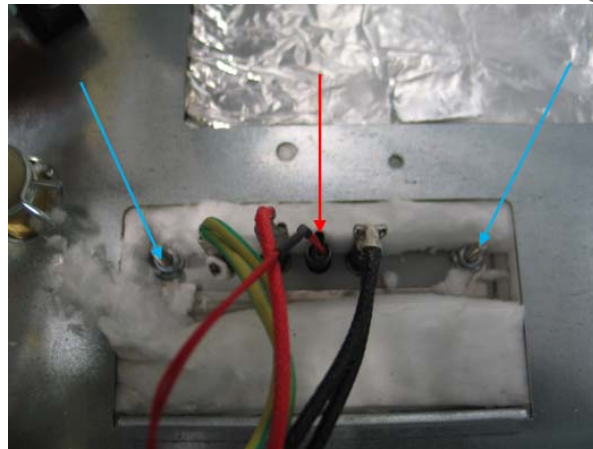

Figure 2



Figure 3

Bottom element Substitution

1. Disconnect the power supply cord and remove the Oven from the cabinet.
2. Remove the upper and rear covers.
3. Disconnect the terminals.
4. Unscrew the two screws (fig.1).
5. Remove the element as shown (fig2).
6. Replace the new one by reversing the previous steps.

Note: The element must be placed as shown en the figure blow.

7. Connect the terminals and insert the temperature probe, crushing the entrance to make oval it to prevent the escape.
8. The connections must not be loose.
9. Reinstall the Oven into the cabinet.
10. Reconnect the power supply cord after the Oven is installed.
11. Run the Oven and check all functions.

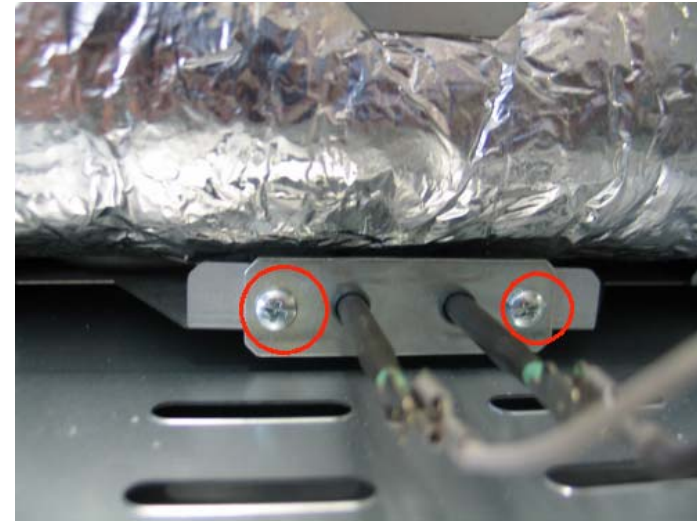
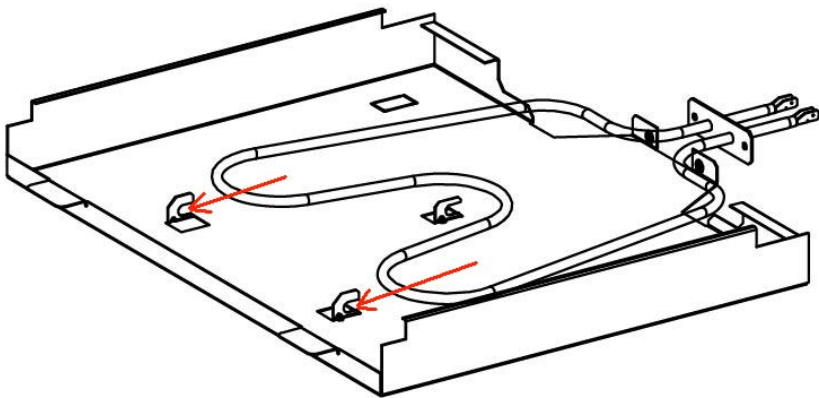

Fig.1

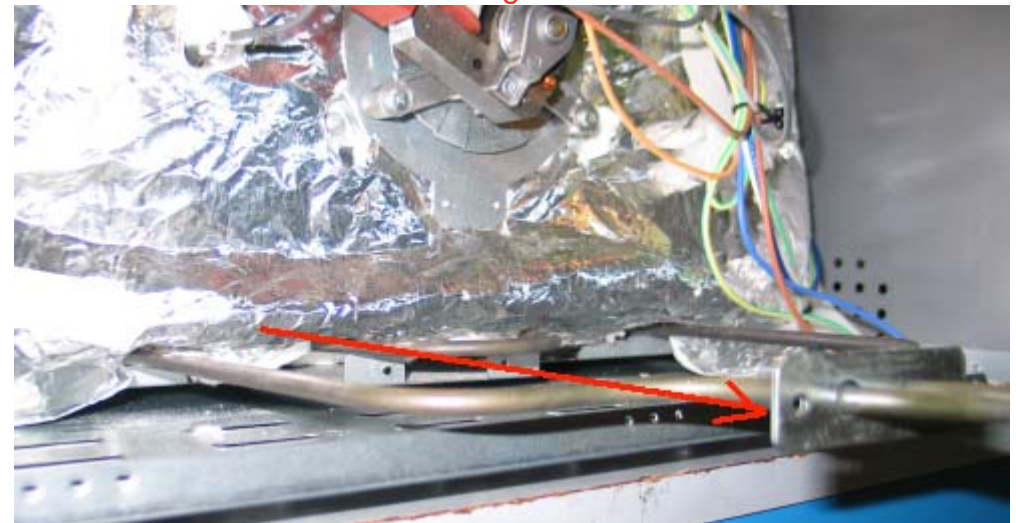

Fig.2

Door Gasket substitution



1. Open door and pull out the gasket by hands unhooking it by its 4 hooks on the corners.
2. Replace with a new one by reversing the previous steps.
3. Run the Oven and check all functions.



Safety thermostats substitution

1. Disconnect the power supply cord and remove the Oven from the cabinet.
2. Remove the upper cover.
3. Unscrew and disconnect the thermostat damaged.
4. Replace the new one by reversing the previous steps.
5. Connect the terminals. The connections must not be loose.
6. Reinstall the Oven into the cabinet.
7. Reconnect the power supply cord after the Oven is installed.
8. Run the Oven and check all functions.

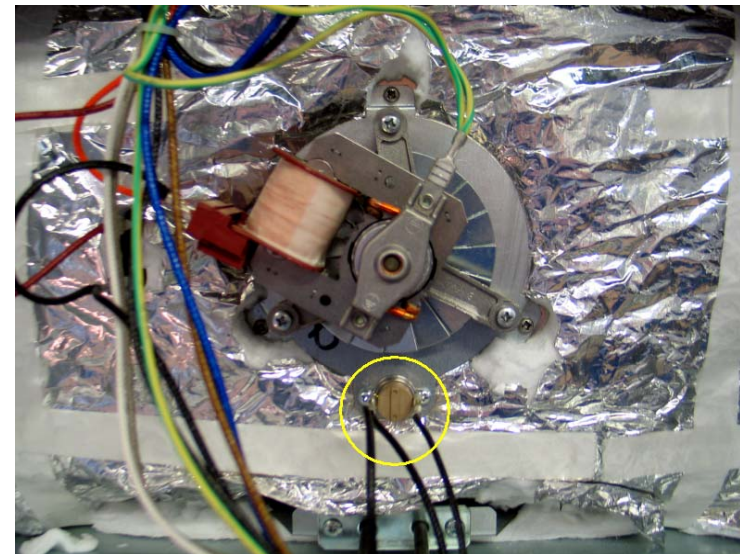
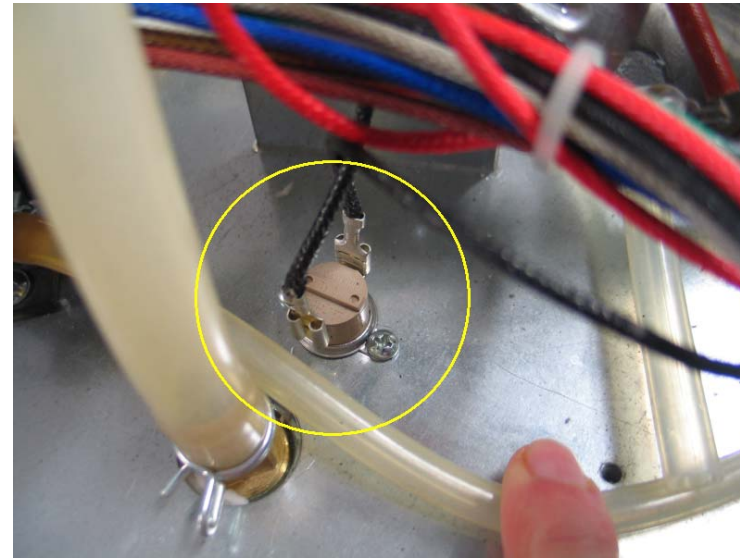

Probe Temperature substitution

1. Disconnect the power supply cord and remove the Oven from the cabinet.
2. Remove the upper cover.
3. Remove the internal components cover (fig 1) by its six screws.
4. Remove the probe from its location using a clamp make rounded the border to extract it (fig.2).
5. Disconnect the terminals (fig.3).
6. Replace the new one by reversing the previous steps
7. Connect the terminals and insert the temperature probe, crushing the entrance to make oval it to prevent the escape.
8. The connections must not be loose.
9. Reinstall the Oven into the cabinet.
10. Reconnect the power supply cord after the Oven is installed.
11. Run the Oven and check all functions.

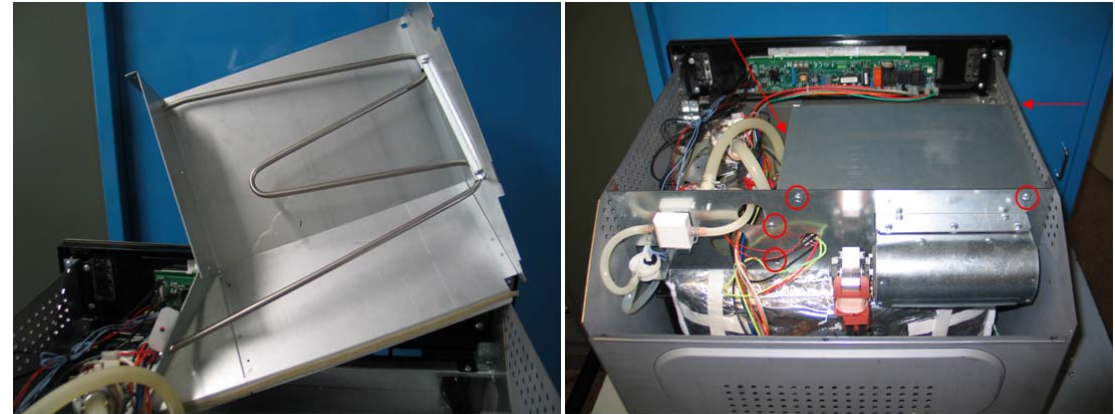

Figure1

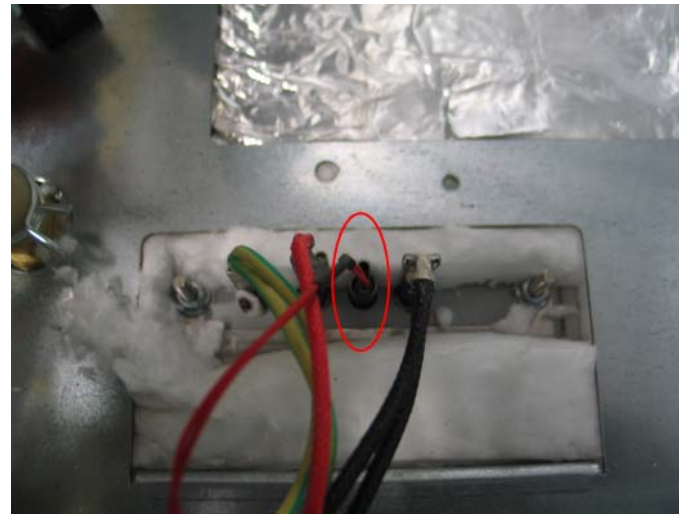

Figure 2

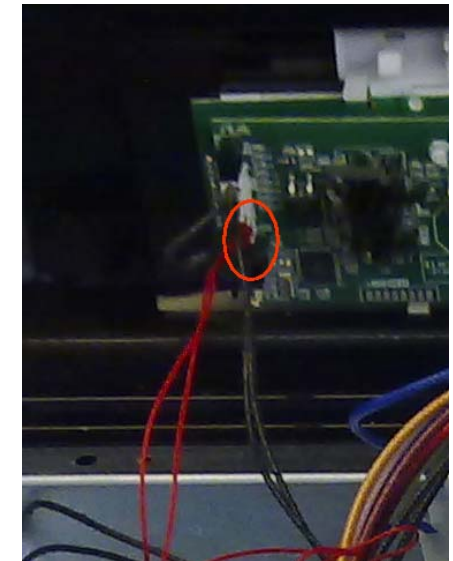

Figure 3

Door hinges substitution

1. Remove the Oven door following the [section 7.3](#).
2. Put the door on a flat surface with a soft cloth to prevent scratching of the aesthetics.
3. Unscrew the door external glass **A**.

Before to remove the hinges the hinge arm must be placed in the correct position following the steps (1 to 4) below.

4. Remove the hinges unscrewing its screws **B**.
5. To replace the hinges, reverse the previous steps.
6. To replace the aesthetic glass be sure that the door are in the right position keeping the glass centered.
7. Replace the Oven door following the [section 7.3](#).

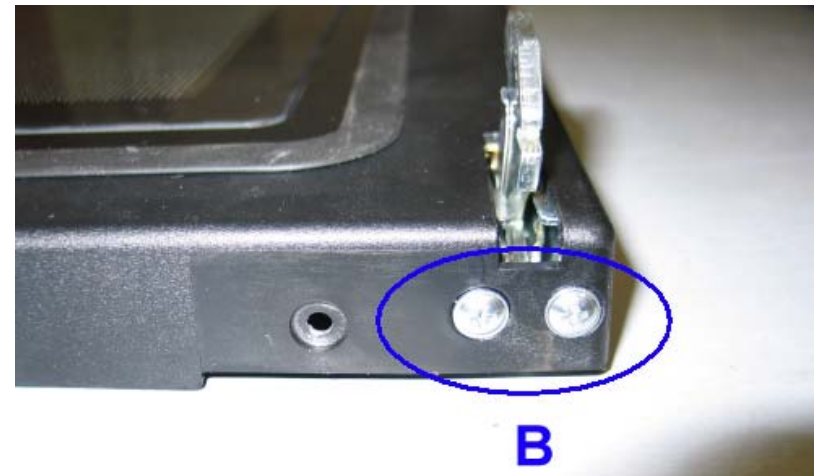
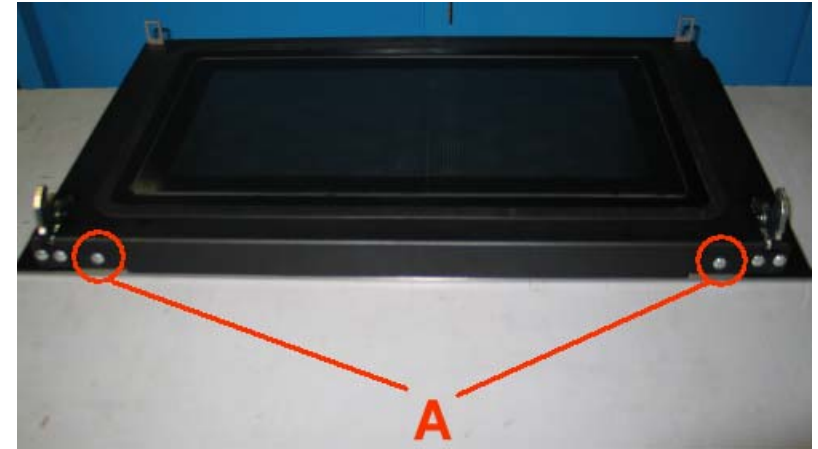

Electronic Control board substitution



1. Disconnect the power supply cord and remove the Oven from the cabinet.
2. Remove the upper cover.
3. Disconnect the bad Control Board and remove it by its four plastic bracket. (fig.1)
4. Replace the new one by reversing the previous steps.
5. Connect the terminals. The connections must not be loose.
6. Reinstall the Oven into the cabinet.
7. Reconnect the power supply cord after the Oven is installed.
8. Run the Oven and check all functions .



Fig.1



Light bulb substitution

1. Disconnect the power supply cord.
2. Remove the upper, rear and lateral cover .
3. Open the door and remove the lens to access to bulb as showed **(fig. 1)**.

The oven lamp must have precise characteristics:

- a) Structure suitable for high temperatures (up to 300 °C);
- b) Power supply: see the V/Hz value on the serial number plate;
- c) Power 25W;
- d) Type G9 connector.

Note: To avoid damage, spread a tea towel for pots and pans inside the oven;

4. Reconnect the power supply cord after the Oven is installed.
5. Run the Oven and check all functions.

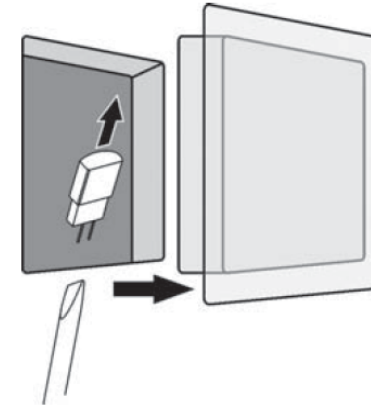
**Fig.1**

Load & Drain Pump substitution

1. Disconnect the power supply cord and remove the Oven from the cabinet.
2. Remove the upper cover.
3. Disconnect the terminals from bad Pump.
4. Disconnect the silicon tubes from pump body.
5. Remove it by removing the fixing screws.
6. Replace the new one by reversing the previous steps.
7. Connect the terminals. The connections must not be loose.
8. Reinstall the Oven into the cabinet.
9. Reconnect the power supply cord after the Oven is installed.
1. Run the Oven and check all functions

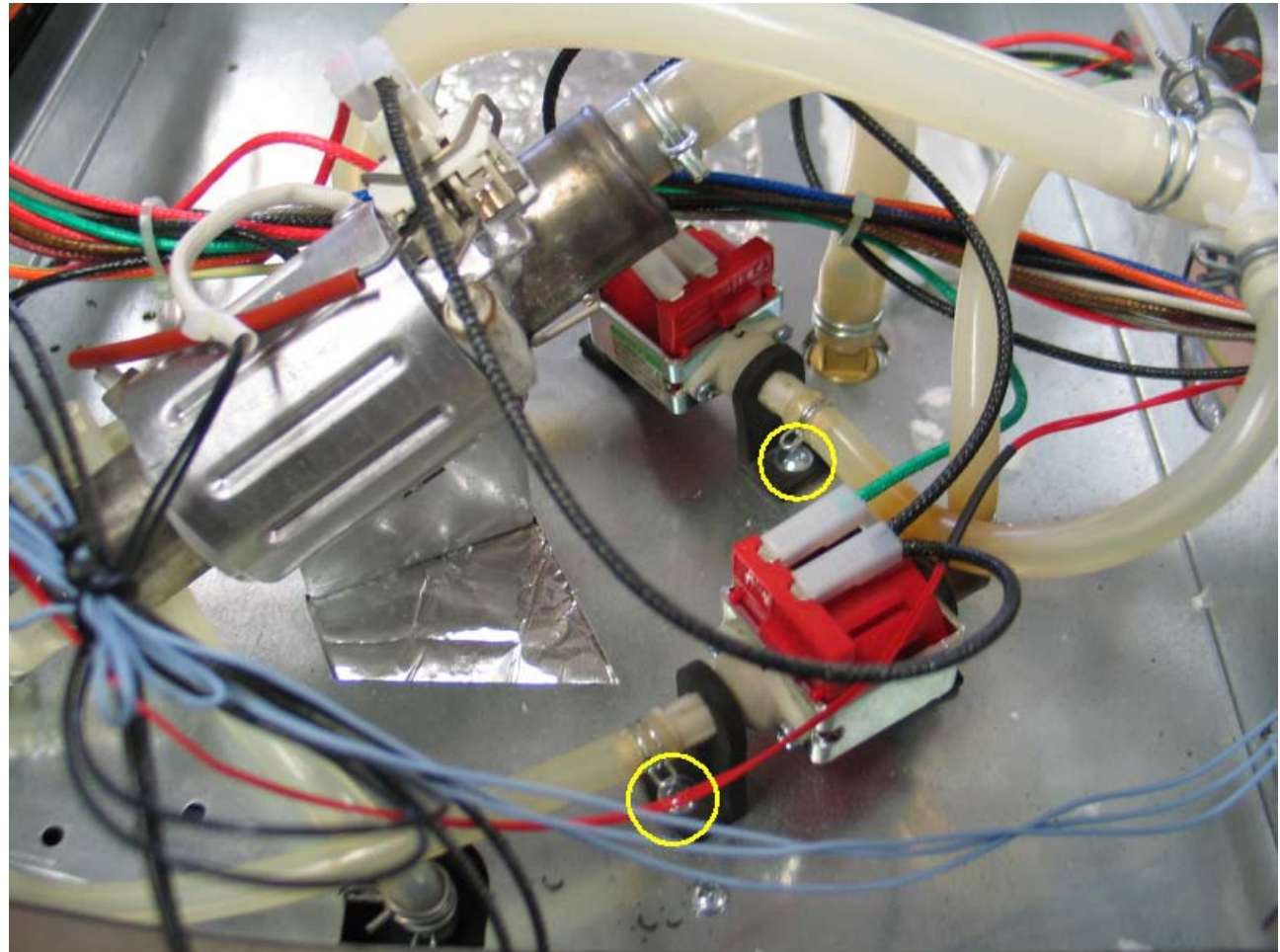

Steam generator substitution

1. Disconnect the power supply cord and remove the Oven from the cabinet.
2. Remove the upper cover.
3. Disconnect the terminals from bad Generator.
4. Disconnect the silicon tubes from its body.
5. Remove it by removing the fixing screws positioned under the generator body.
6. Replace the new one by reversing the previous steps.
7. Connect the terminals. The connections must not be loose.
8. Reinstall the Oven into the cabinet.
9. Reconnect the power supply cord after the Oven is installed.
1. Run the Oven and check all functions

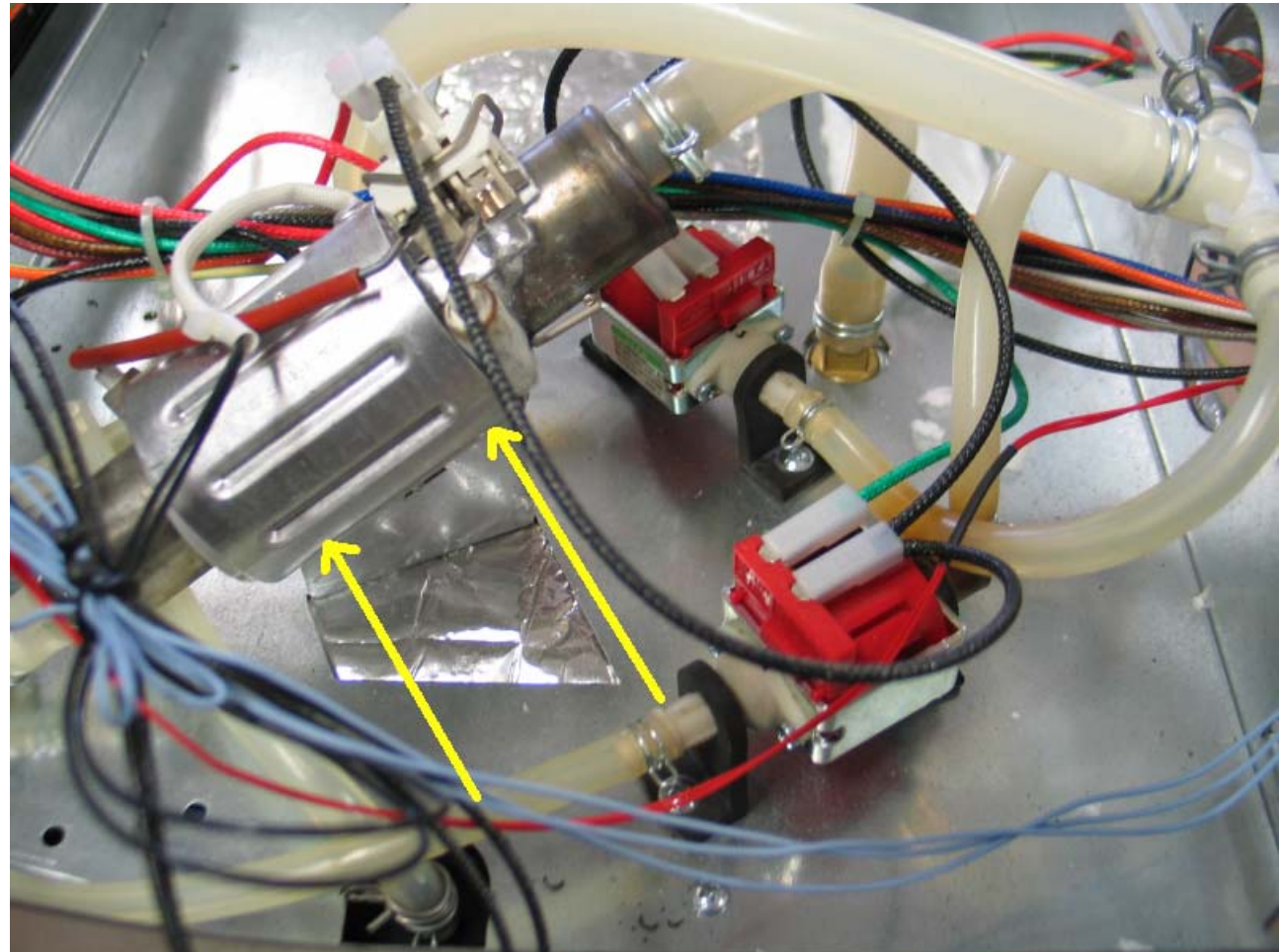

Water Softener substitution

1. Disconnect the power supply cord and remove the Oven from the cabinet.
2. Remove the upper cover.
3. Disconnect the silicon tubes from its body.
4. Replace the new one by reversing the previous steps.
5. Connect the terminals. The connections must not be loose.
6. Reinstall the Oven into the cabinet.
7. Reconnect the power supply cord after the Oven is installed.
1. Run the Oven and check all functions

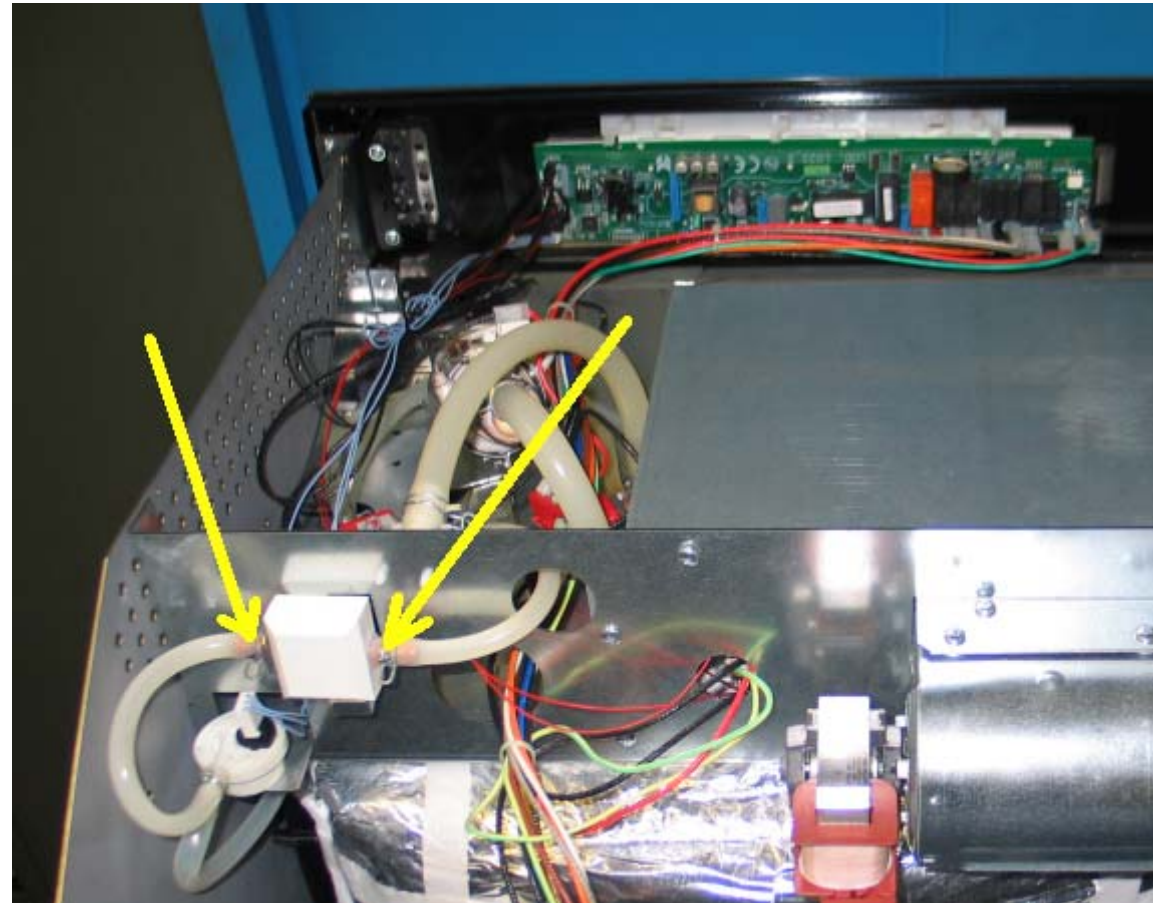

Water Counter substitution

1. Disconnect the power supply cord and remove the Oven from the cabinet.
2. Remove the upper cover.
3. Disconnect the terminals from bad water counter.
4. Disconnect the silicon tubes from its body.
5. Remove it by the its fixing plastic plug positioned under the counter body.
6. Replace the new one by reversing the previous steps.
7. Connect the terminals.
8. Reinstall the Oven into the cabinet.
9. Reconnect the power supply cord after the Oven is installed.
1. Run the Oven and check all functions

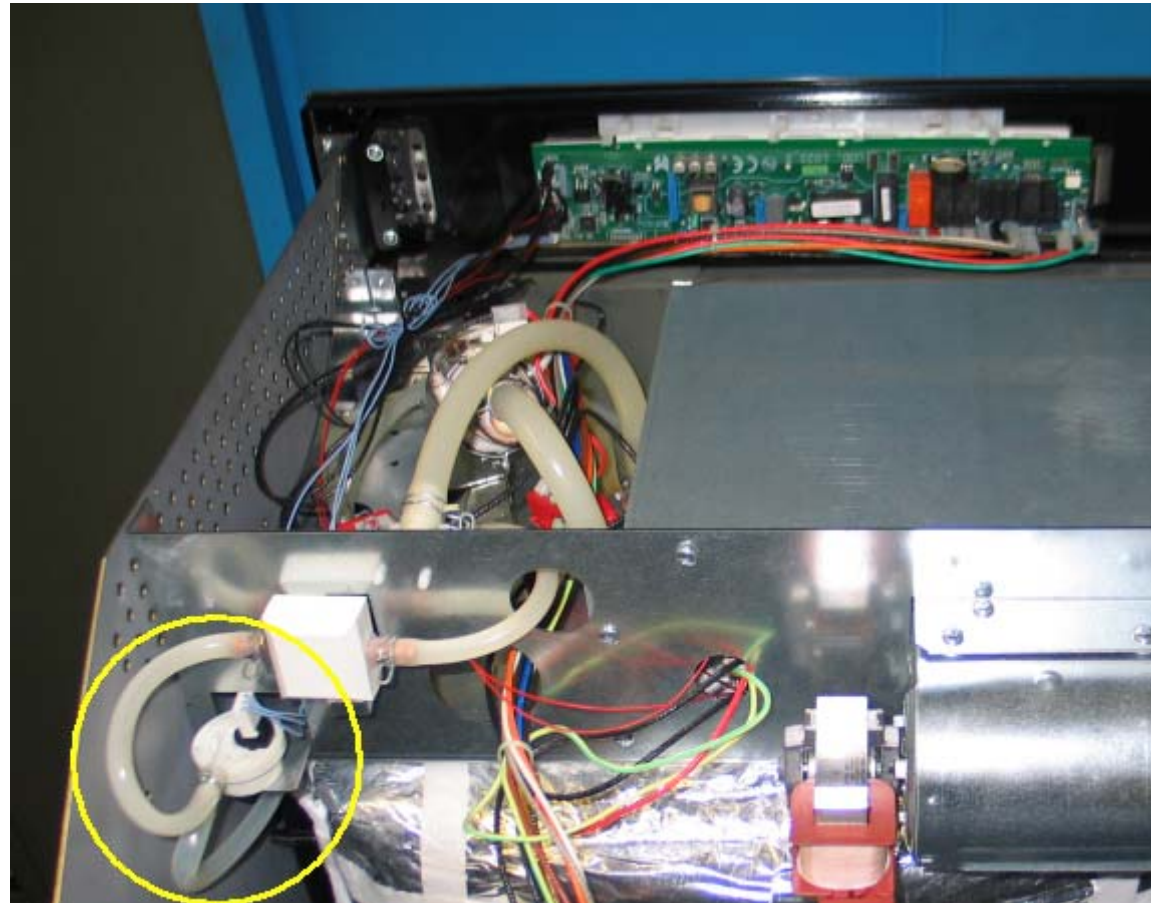

Door Sensor substitution

1. Disconnect the power supply cord and remove the Oven from the cabinet.
2. Remove the upper cover.
3. Disconnect the connector of the bad sensor from board.
4. Remove it by removing its fixing screw.
5. Replace the new one by reversing the previous steps.
6. Connect the connector.
7. Reinstall the Oven into the cabinet.
8. Reconnect the power supply cord after the Oven is installed.
1. Run the Oven and check all functions

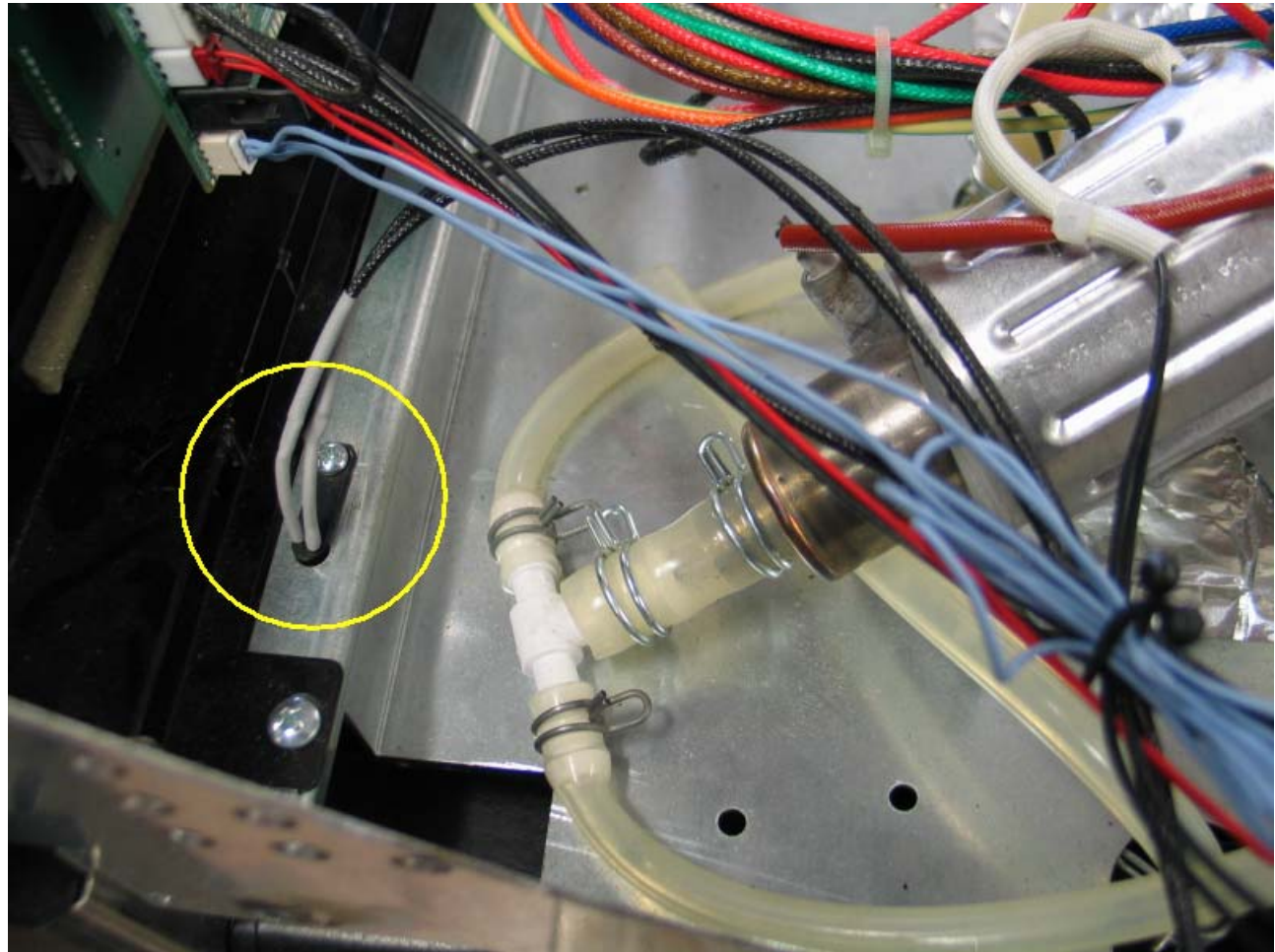

Door external glass substitution

1. Remove the door from the oven [section 7.3](#).
2. Put the door on a flat surface with a soft cloth to prevent scratching of the aesthetics.
3. Remove the external glass from the door unscrewing two screws on the corner ([fig.1](#)).
4. Remove also the handle by its two screws to mount it on the new glass ([fig.2](#)).
5. Replace the handle on the new aesthetic glass with its [support](#).
6. Assemble the glass and door keeping door in the middle of the glass.
7. Replace the Oven door following the [section 7.3](#).



Figure 1

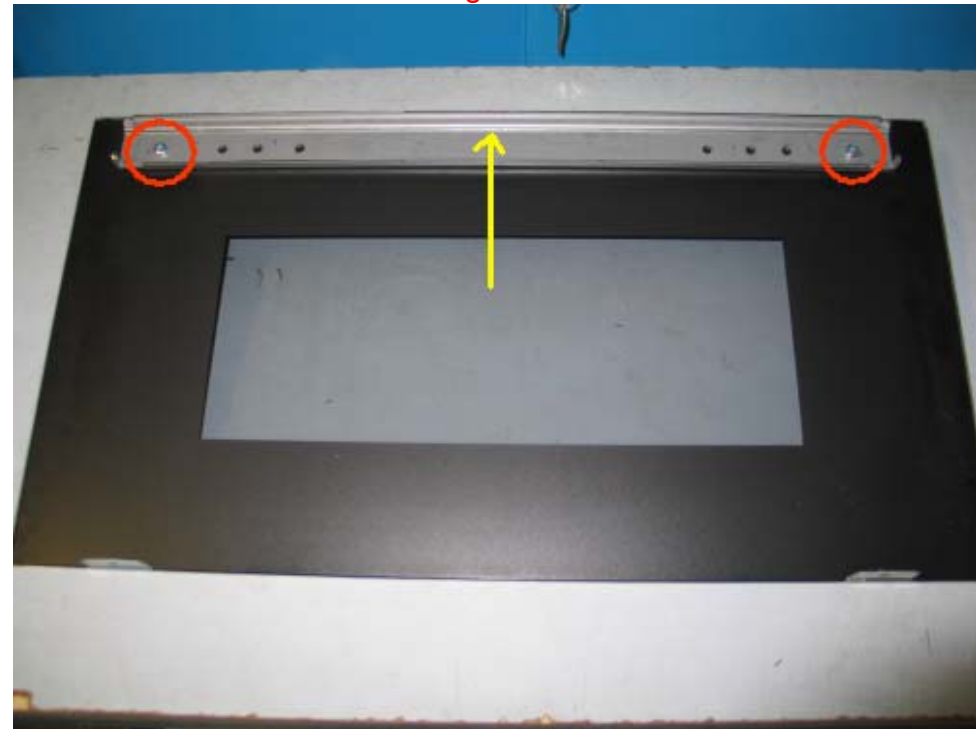

Figure 2

Door middle glass substitution

1. Remove the door from the oven [section 7.3](#).
2. Put the door on a flat surface with a soft cloth to prevent scratching of the aesthetics.
3. Remove the external glass from the door unscrewing two screws on the corner ([fig.1](#)).
4. Remove the middle glass damage and to replace with the new one



Figure 1

Version with labyrinth

When it is changed an middle glass you must be sure that the face whit (THERMO REFLECTIVE) printed it is towards the cavity ([fig.2](#)).

5. Assemble the glass and door keeping door in the middle of the glass.
6. Replace the Oven door following the [\(section 7.3\)](#).
7. Run the Oven and check all functions.



Figure 2

Version without labyrinth (remove the showed screws)

Door internal labyrinth glass substitution

1. Remove the door from the oven [section 7.3](#).
2. Put the door on a flat surface with a soft cloth to prevent scratching of the aesthetics.
3. Remove the external glass from the door unscrewing two screws on the corner ([fig.1](#)).
4. Remove also the middle glass by hands.

When it is changed or removed an middle glass you must be sure that the face whit (THERMO REFLECTIVE) printed it is towards the cavity ([fig.2](#)).

5. To remove the labyrinth unscrew the six screws from its frame ([fig.3](#)).
6. Assemble the new one by previous reverse steps
7. Assemble the external glass and door keeping door in the middle of the glass.
8. Replace the Oven door following the [\(section 7.3\)](#).
9. Run the Oven and check all functions .



Figure 1



Figure 2



Figure 3

Door internal labyrinth glass gasket substitution

1. Remove the door from the oven [section 7.3](#).
2. Put the door on a flat surface with a soft cloth to prevent scratching of the aesthetics.
3. Remove the external glass from the door unscrewing two screws on the corner ([fig.1](#)).
4. Remove also the four brackets on the corner to remove the middle glass.

When it is changed or removed an middle glass you must be sure that the face whit (THERMO REFLECTIVE) printed it is towards the cavity ([fig.2](#)).

5. To remove the labyrinth unscrew the six screws from its frame, and dismount the gasket damaged by hand. ([fig.3](#)).
6. Assemble the new one by previous reverse steps.
7. Assemble the external glass and door keeping door in the middle of the glass
8. Replace the Oven door following the [\(section 7.3\)](#).
9. Run the Oven and check all functions.



Figure 1



Figure 2



Figure 3

Glass Control panel substitution



1. Disconnect the power supply cord and remove the Oven from the cabinet.
2. Remove the upper cover.
3. Remove the Control Board without disassembling the cable. ([section 7.12](#))
4. Substitute the glass damaged by removal of the four screws on metal brackets. ([fig.1](#))
5. Replace the new one by reversing the previous steps mounting also a new plastic control board brackets. ([fig.2](#))
6. Reinstall the Oven into the cabinet.
7. Reconnect the power supply cord after the Oven is installed.
8. Run the Oven and check all functions .



Fig.2

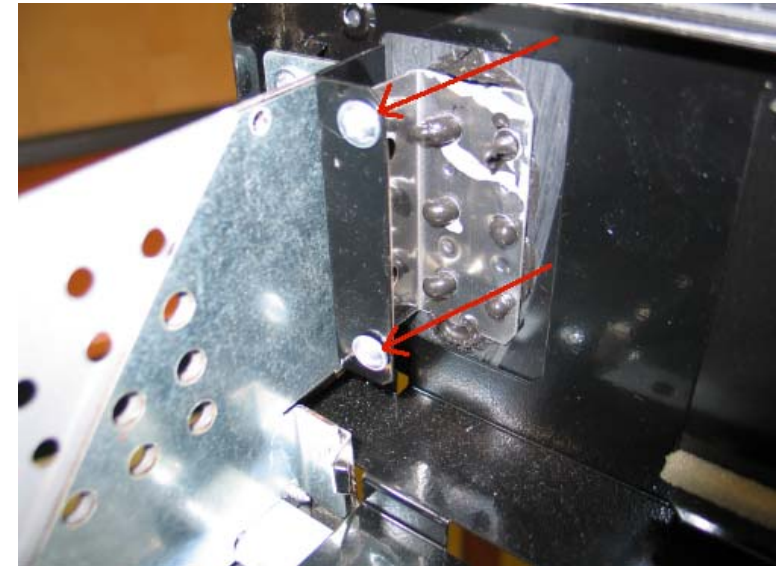

Fig.1

Door magnet substitution

1. Remove the door from the oven ([section 7.3](#)).
2. Put the door on a flat surface with a soft cloth to prevent scratching of the aesthetics.
3. Remove the external glass from the door unscrewing two screws on the corner ([fig.1](#)).
4. Remove also the four brackets on the corner to remove the middle glass.

When it is changed or removed an middle glass you must be sure that the face whit (THERMO REFLECTIVE) printed it is towards the cavity ([fig.2](#)).

5. To remove the labyrinth unscrew the six screws from its frame, and dismount the magnet damaged by hand. ([fig.3](#)).
6. Assemble the new one by previous reverse steps.
7. Assemble the external glass and door keeping door in the middle of the glass
8. Replace the Oven door following the ([section 7.3](#)).
9. Run the Oven and check all functions .



Figure 1



Figure 2

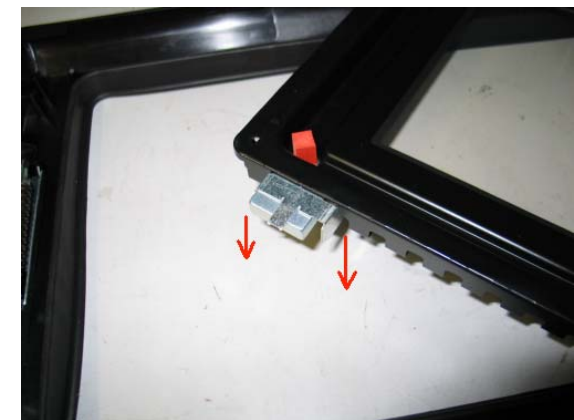

Figure 3