



CM109

Caple Built In Microwave / Grill



Technical information



New product information sheet

Product name: CM109
Description: Caple Built In Microwave / Grill
Product code: CM109

Features

Built-in

Stainless steel and glass

11 functions:

- light
- *microwave*
- *microwave + grill*
- *microwave + fan*
- *grill*
- *grill + fan*
- *fan + convection*
- *speed defrost (inc pastry/ bread defrost function*
- *microwaves, convection and fan*
- *boost*
- *clean function*

Stainless steel interior

Black-spot feature bar handle

32 Litre capacity

3 Microwave power levels

Thermostatic grill

grill can be lowered for cleaning

60 preset cooking recipes that can be customized

Touch control timer and electronic clock

Keep Warm function if door remains closed after cooking

Express microwave programme

Audible timer

Cooking output

Fan cooking 150W

Microwave cooking 1000W

Grill 150W





New product information sheet

Product name: CM109
Description: Caple Built In Microwave / Grill
Product code: CM109

Accessories

- Dia. 320mm glass turntable
- 1 round chrome shelf
- 1 chrome grid
- 1 stainless steel tray

Optionals:

- 1 round chrome high shelf
- 1 glass tray

Electrical connection

- Rated load 3.10kW
- Fuse rating 20A





CM109

Caple Built In Microwave / Grill

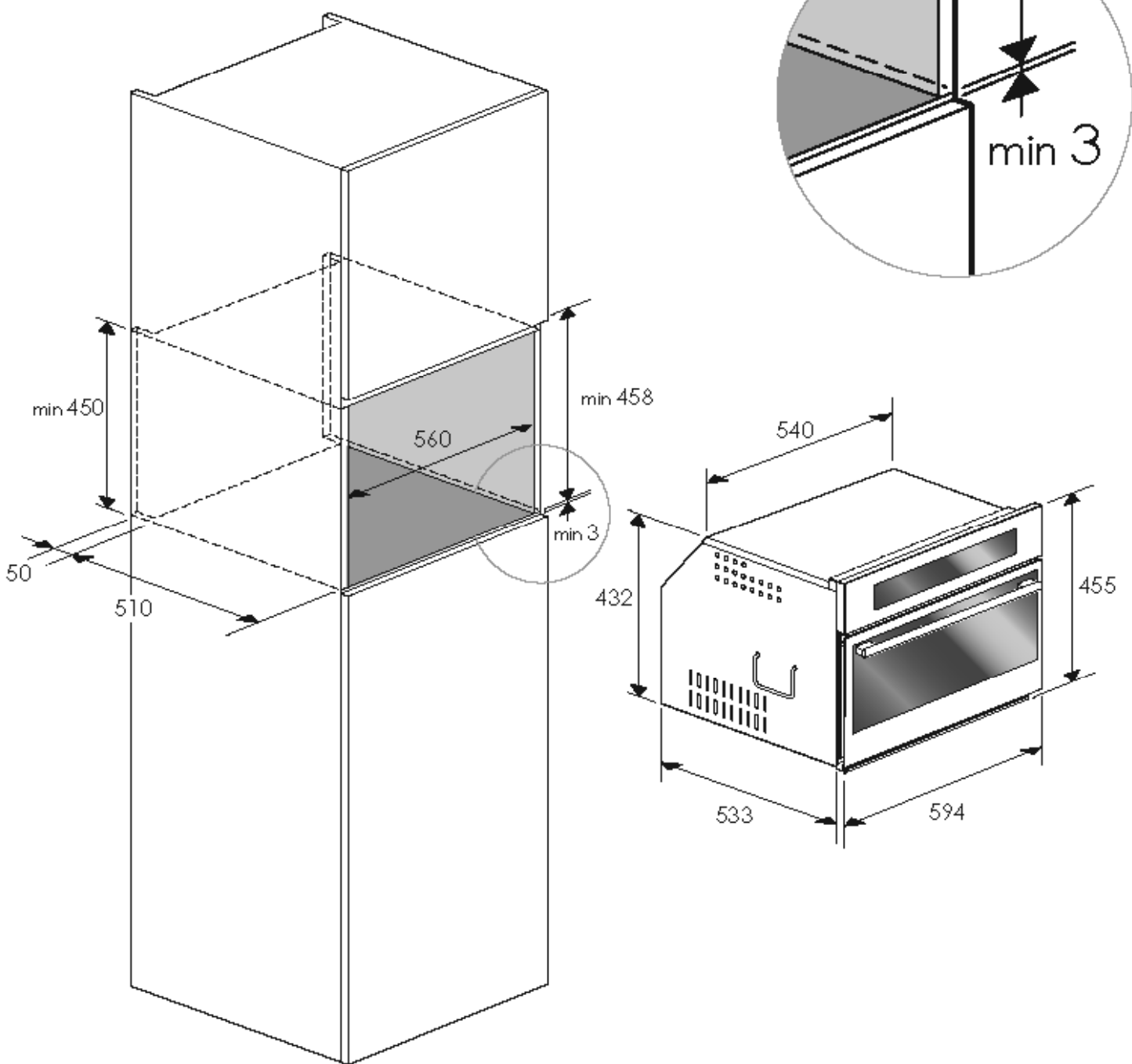



CM109

Caple Built In Microwave / Grill

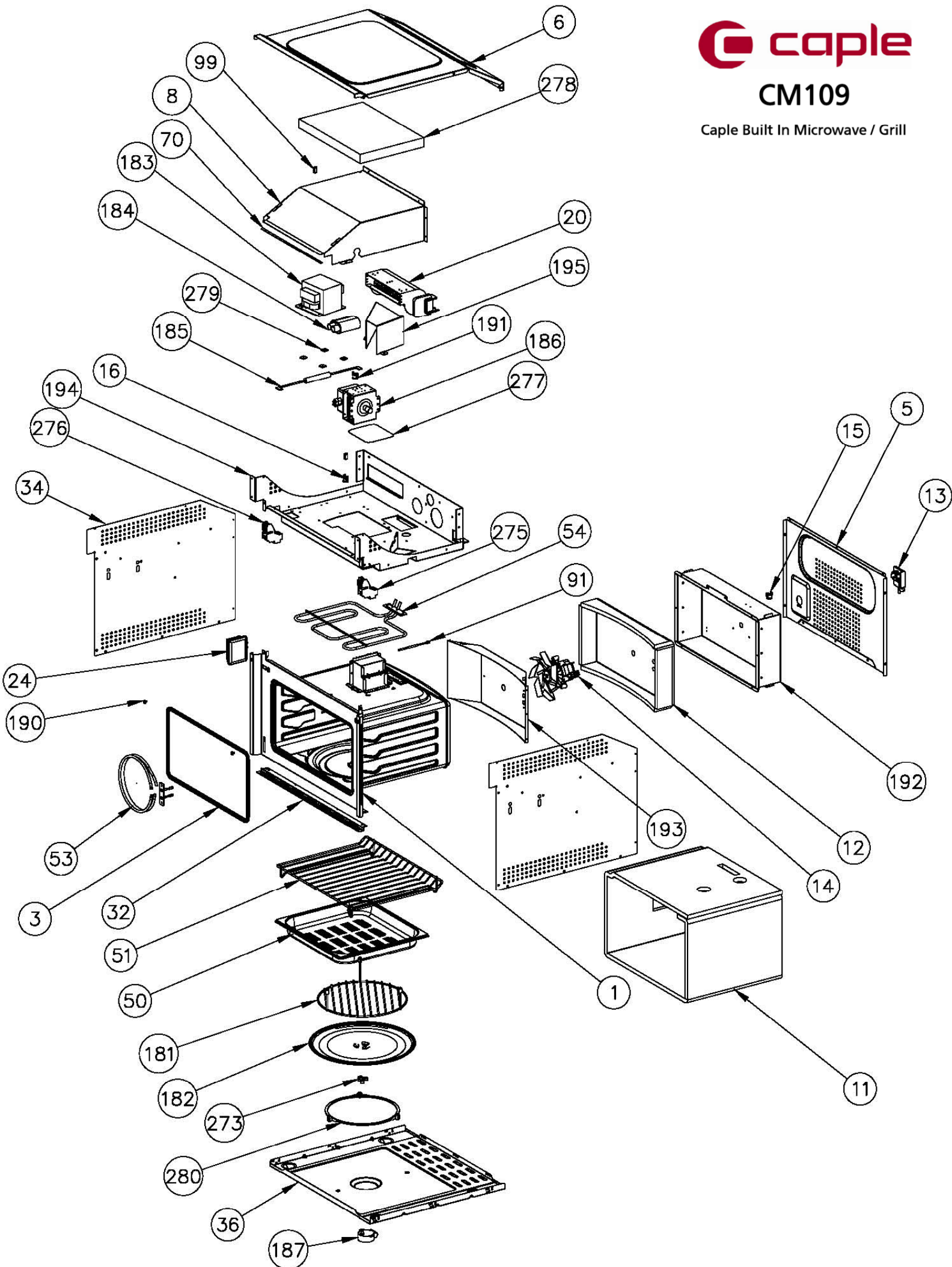



CM109

Caple Built In Microwave / Grill

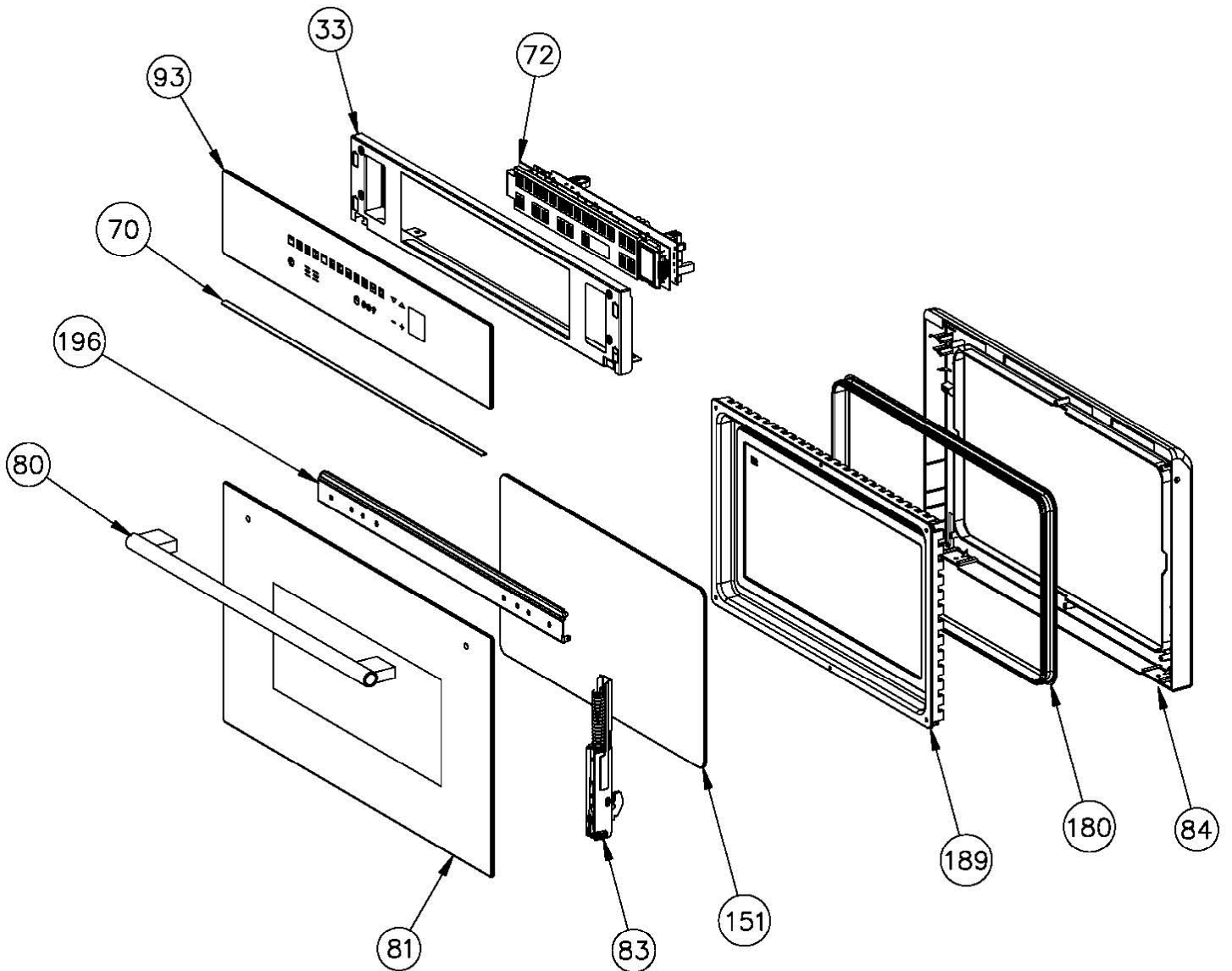



CM109 - Caple built in microwave

Item	Part Code	Description
1a	42700800	MUFFLE (until 06/05/12)
1b	42700950	MUFFLE (from 07/05/12 until 13/03/13)
1c	42703120	MUFFLE (from 14/03/13)
3a	12380990	MUFFLE GASKET (until 08/04/13)
3b	12381850	MUFFLE GASKET (from 09/04/13 until 23/03/14)
3c	12382130	MUFFLE GASKET (from 24/03/14)
5	12111260	BACK SHIELD
6	12111170	TOP SHIELD
8	12111860	AIR CONVEYOR F45N µONDE
11a	12380970	FIBERGLASS SHELL (until 06/05/12)
11b	12381530	FIBERGLASS SHELL (from 07/05/12)
12	12380980	FIBERGLASS REAR
13	12530000	TERMINAL BLOCK/FASTEN CABLE 16A
14a	12590031	RADIAL FAN (until 22/07/12)
14b	12590191	RADIAL FAN (from 23/07/12)
15	12540943	SAFETY THERMOSTAT PRESET T165°C
16	12540944	SAFETY THERMOSTAT PRESET T110°C
20	12590150	TANGENTIAL COOLING FAN
24	12540960	HALOGEN RECTANGULAR LAMP SOCKET 25W 230/240V
32a	12191131	LOWER PROFILE F45 BLACK (until 17/01/12)
32b	12192671	LOWER PROFILE F45N STEAM BLACK (from 18/01/12)
33a	12111871	COUNTER FRONTAL (until 02/09/12)
33b	12112541	COUNTER FRONTAL (from 03/09/12)
34a	12112300	LEFT-RIGHT SIDE SHIELD (until 23/10/11)
34b	12112400	LEFT-RIGHT SIDE SHIELD (from 24/10/11)
36	12111810	BOTTOM SHIELD
50	12105340	TRAY µF45N H40 INOX
51a	12200330	SHELF (until 13/03/13)
51b	12200460	SHELF (from 14/03/13)
53	12570170	CIRCULAR HEATING ELEMENT 1500W
54	12570180	GRILL HEATING ELEMENT 1500W
70	12380950	ADHESIVE GASKET
72	42782041	INTERACTIVE POWER BOARD MICROWAVE 11F µF45N W/COOKBOOK
80	12740600	HANDLE SENSEHAN1 MAURICE LAY
81	42712824	GLASS DOOR
83	12600280	DOOR HINGE
84a	12300680	INNER DOOR µF45N (until 22/07/13)
84b	12301000	INNER DOOR (from 23/07/13)
91a	12541190	NTC PROBE (until 26/07/15)
91b	12542090	NTC PROBE (from 27/07/15)
93	42715576	FRONTAL GLASS
99	12380500	RUBBER FOOT FOR HINGE (from 21/03/12)
151	12323500	3rd INNER GLASS THERMO REFLECTIVE
180	12381000	DOOR GASKET



CM109 - Caple built in microwave

Item	Part Code	Description
181a	12702000	ROUND SHELF H75 (until 06/10/13)
181b	42702000	ROUND SHELF H75 (from 07/10/13)
182	12380930	FLAT GLASS SWIVEL
183	12541110	TRANSFORMER
184	12541120	CAPACITOR 2100Vac 50/60Hz 1.05 μ F
185	12541130	FUSE CARRIER + FUSE 0.8A-5kV
186	12570160	MAGNETRON
187	12590140	GEARMOTOR
188	12600250	SECURITY MICRO CAMS ROD (until 06/05/12)
189	42710590	LABYRINTH μ F45N
190	11380640	CAST IRON RUBBER GRILL
191	12541100	SAFETY THERMOSTAT T120 ϕ C MAGNETRON
192	12112490	EXTERNAL BOTTOM
193	12111850	BOTTOM PROTECTION
194a	12111830	COMPONENT SUPPORT (until 27/05/12)
194b	12112480	COMPONENT SUPPORT (from 28/05/12)
195	12192440	AIR CONVEYOR F45N MAGNETRON
196a	12192370	INNER DOOR HANDLE PROFILE (until 27/09/12)
196b	12193250	INNER DOOR HANDLE PROFILE (from 28/09/12)
273	12380920	BUSHING FOR FLAT GLASS SWIVEL (from 09/10/12)
275	12782058	MICROSWITCH N/O μ F45 (RIGHT) (from 07/05/12)
276	12782059	MICROSWITCH N/O-N/C μ F45 (LEFT) (from 07/05/12)
277	12380960	MICA PROTECTION
278	12381550	FIBERGLASS DUMPING (from 21/03/12)
279	12381540	RUBBER DUMPING FOR TRANSFORMER (from 09/10/12)
280	12600230	SLIDING BLOCK FOR ROTATING PLATE (from 09/10/12)



CM109 Fault Codes

E1 – Cavity probe opened and in short circuit

E2 – Micro switch of door broken

E3 – Control Board overheating (higher than 85degrees)

E4 – Control Board broken

E5 – Flexible Control Board broken

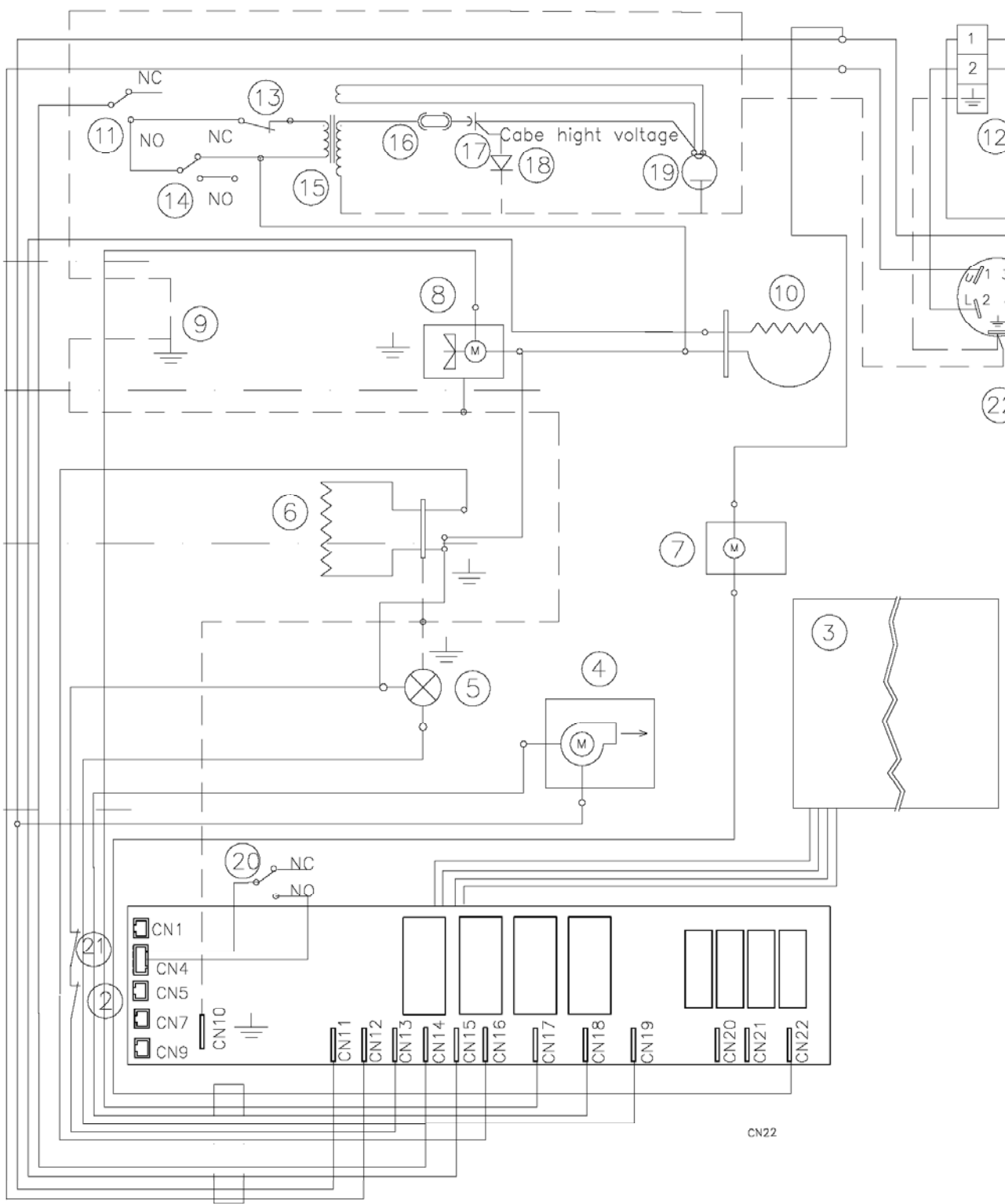

LEGEND

- 1- Power board
- 2- Thermal cut-out
- 3- Display board
- 4- Cooling fan motor
- 5- Oven light
- 6- Grill heating element
- 7- Rotating motor plate
- 8- Fan motor
- 9- Earth appliance
- 10- Circular heating element
- 11- Primary switch
- 12- Terminal supply
- 13- Thermal cut-out
- 14- Monitor switch
- 15- Trasformer
- 16- Fuse hight voltage
- 17- Capacitor
- 18- Diode
- 19- Magnetron
- 20- Secondary switch/light and door
- 21- Thermal cut-out
- 22- Filter

SYMBOL LEGEND

- CN1= Boiler (CALDAIA)
 - CN4= Opnenig/closing door (PORTA)
 - CN5= Temperature probe (CAMERA)
 - CN7= Meat probe (CUORE)
 - CN9= Flow sensor (LIVELLO)
 - CN11= Neutral
 - CN12= Line
 - CN13= Neutral
 - C14= Magneltron/Boiler
 - CN15= circular heating element (CIRC)
 - CN16= Grill heating element (GRILL)
 - CN17= Fan motor (V.RAD.)
 - CN18= Cooling fan motor (V.EXT.)
 - CN19 = Oven Light (LUCE)
 - CN20= Botton heating element (SUOLA)
 - CN21= Drain pump (SCARICO)
 - CN22= Motor late/Chargepump (PIATTO/CARICO)
- — — Earth wire



CM109

Caple Microwave



CM109

Caple built in Microwave/Grill



Service Manual

CONTENTS

1. SERVICING REQUIREMENTS

1.1 HEALTH & SAFETY

- 1.1.1 *Electrical Safety*
- 1.1.2 *Good Working Practices*
- 1.1.3 *Insulation Test*
- 1.1.4 *Sheet Metal Edges*
- 1.1.5 *Microwave emissions*

1.2 MEASUREMENT OF ENERGY EMISSION

- 1.2.1 *Measurement of energy emission*
- 1.2.2 *All repairs must be performed in such a manner that microwave energy emission is minimal.*

1.3 SPECIAL TOOLS & MATERIALS

- 1.3.1 *Tools*
- 1.3.2 *Necessary Measuring Instrument*

2. TECHNICAL OVERVIEW

2.1 OVEN MICROWAVE SPECIFICATIONS

- 2.1.1 *Oven Weight*
- 2.1.2 *Power Rating*

2.2 SERIAL PLATE

- 2.2.1 *Location*
- 2.2.2 *Model and Serial Number*

2.3 COMPONENT SPECIFICATIONS

- 2.3.1 *Heating Elements*
- 2.3.2 *Motors*
- 2.3.3 *Electric Components*

2.4 SYSTEM DESCRIPTION

2.5 TEST PROCEDURE MICROWAVE CONTROL

2.6 FAULT NUMBERS

2.7 OVEN SAFETY FUTURES

- 2.7.1 *Interlock Mechanism*
- 2.7.2 *Safety Thermostats*

4. TROUBLE SHOOTING GUIDE

- 4.1 [ERROR MESSAGE](#)
- 4.2 [MICROWAVE OVEN DOESN'T WORK](#)
- 4.3 [COOLING FAN PROBLEMS](#)
- 4.4 [CONVECTION FAN PROBLEMS](#)
- 4.5 [OVEN LIGHT PROBLEMS](#)
- 4.6 [DISPLAY PROBLEMS](#)
- 4.7 [DOOR HINGES PROBLEMS](#)
- 4.8 [BAD COOKING PERFORMANCE](#)

7. COMPONENT REPLACEMENT AND ADJUSTMENT PROCEDURE

- 7.1 [MICROWAVE OVEN REMOVAL](#)
- 7.2 [COOLING FAN MOTOR SUBSTITUTION](#)
- 7.3 [OVEN DOOR REMOVAL](#)
- 7.4 [CONVECTION FAN MOTOR SUBSTITUTION](#)
- 7.5 [RING ELEMENT SUBSTITUTION](#)
- 7.6 [GRILL ELEMENT SUBSTITUTION](#)
- 7.7 [ROTATING DISH MOTOR SUBSTITUTION](#)
- 7.8 [MAGNETRON SUBSTITUTION](#)
- 7.9 [LOCK DOOR SWITCH SUBSTITUTION](#)
- 7.10 [DOOR GASKET SUBSTITUTION](#)
- 7.11 [SAFETY THERMOSTATS SUBSTITUTION](#)
- 7.12 [TRANSFORMER SUBSTITUTION](#)
- 7.13 [CONDENSER SUBSTITUTION](#)
- 7.14 [TEMPERATURE PROBE SUBSTITUTION](#)
- 7.15 [DOOR HINGES SUBSTITUTION](#)
- 7.16 [DIODE SUBSTITUTION](#)
- 7.17 [FILTER SUBSTITUTION](#)
- 7.18 [ELECTRONIC CONTROL BOARD SUBSTITUTION](#)
- 7.19 [FUSE SUBSTITUTION](#)
- 7.20 [DOOR EXTERNAL GLASS SUBSTITUTION](#)
- 7.21 [DOOR MIDDLE GLASS SUBSTITUTION](#)
- 7.22 [DOOR INTERNAL LABYRINTH GLASS SUBSTITUTION](#)
- 7.23 [DOOR INTRENAL LABYRINTH GLASS GASKET SUBSTITUTION](#)
- 7.24 [GLASS CONTROL PANEL SUBSTITUTION](#)
- 7.25 [LIGHT BULB SUBSTITUTION](#)

Note: When servicing the oven, health and safety issues must be considered at all times. Specific safety issues are listed below with their appropriate icon. These are illustrated throughout the service information to remind service people of the health and safety issues

1.1.1 **Electrical Safety**



WARNING! TO AVOID ELECTRIC SHOCK!

Do not attempt to service this oven without suitable training and qualifications.

Unlike other appliances, the microwave oven is high-voltage and high-current equipment.

Though it is free from danger in ordinary use, extreme care should be taken during repair.

BEFORE TOUCHING any parts of the oven, always remove the power plug from the outlet.

For about 60 seconds after the oven stops, an electric charge remains in the high voltage capacitor. When replacing or checking, you must wait to permit the capacitor discharging.

Ensure the main power has been disconnected before servicing any part of the oven. If the power is required to be on for electrical fault finding, then **extreme** care should be taken not to make contact with electrical components other than with testing probes.

Ensure the oven is turned off when removing any electrical component or connection.

1.1.2 **Good Working Practices**



Ensure the work areas are kept tidy and free of hazards while servicing the oven. On completion of the servicing, ensure the oven and work areas are left clean and tidy.

1.1.3 **Insulation Test**



Megger test to check insulation.

1.1.4 **Sheet Metal Edges**



When working around cut sheet metal edges use appropriate gloves or protection to eliminate the chance of receiving a laceration.

1.1.5 **Microwave emissions**



Precautions to be observed before and during servicing to avoid possible exposure to excessive microwave energy. On every service call. A check for microwave energy emission must be made. It requires that the power density of the microwave radiation emitted by a microwave oven shall not exceed five (5) milliwatts per square centimeter at any point 5 centimeters (about 2 inches) or more from the external surface of the oven.

21 CFR 1030.10, Performance Standard for Microwave Ovens.

Measurement of energy emission**CAUTION**

For microwave energy emission On every service call. A check for microwave energy emission must be made according to the following manner.

**1.2.1 Measurement of energy emission**

Measurement must be made with the microwave oven operating at its maximum output and containing a load of 275±15 milliliters of tap water initially at 20°±5° Celsius (68±9°F) placed within the cavity at the center.

NOTE: The water container must be a 600 milliliter beaker and made of an electrically none conductive material such as glass or plastic. The cook tray must be in place when measuring emission.

A properly operating door and seal assembly will normally register emission no greater than 5 mW/cm² to allow for measurement uncertainty with the cooking shelf or tray in place.

1.2.2 All repairs must be performed in such a manner that microwave energy emission is minimal.

Follow the instructions supplied with the detector being used and perform an R.F. emission test around the door front, and all edges and vent of the outer case. The cabinet (wrapper) must be in place and the oven fully assembled. When performing an emission survey, with the meter on FAST RESPONSE, the movement of the detector probe shall not exceed one (1) inch per second.

In the area emitting the highest reading, switch the meter to SLOW RESPONSE and take a reading for minimum of three (3) seconds. We recommended the pattern outline shown below when the door surface is surveyed.

NOTE: Periodically check to be sure that the probe tip is not worn or dirty.

The following U.S. standard applies to microwave ovens: 21 CFR 1030.10, Performance Standard for Microwave Ovens.

It requires that the power density of the microwave radiation emitted by a microwave oven shall not exceed five (5) milliwatts per square centimeter at any point 5 centimeters (about 2 inches) or more from the external surface of the oven.

All microwave ovens exceeding the emission level of 4 mW/cm² must be reported to Dept. of Service for microwave ovens and the manufacturer immediately. The owner should be told not to use the microwave oven until it has been repaired completely. If a microwave oven is found to operate with the door open, report to Dept. of Service, the manufacturer and CDRH* immediately. Also tell the owner not to use the oven.

*CDRH: Center for Device and Radiological Health. The interlock monitor switch acts as the final safety switch protecting the customer from microwave radiation. If the interlock monitor switch operates properly and the door interlock switch fails, the fuse will blow. If this happens, all interlock switches must be replaced. The contacts of the interlock switches may be welded together.



1.3.1 Tools

- 7.5V Power Screw / Nut Driver Recommended
- 3" socket extension bar
- 7mm socket
- 10 mm socket
- 12mm socket
- Flexible shaft socket extension
- #1 and #2 Short Phillips Screw driver
- Diagonal pliers
- Long nose pliers
- Flat blade screwdriver
- Vinyl insulation tape
- Polishing cloth

1.3.2 Necessary Measuring Instruments

- TESTER (VOLTS-DC, AC, Ohmmeter)
- Microwave survey meter
- Glass thermometer: 100°C or 212°F (1 deg scale)

2.1.1 Oven Weight

lbs /Kg =86/39

2.1.2 Power rating

TECHNICAL DATA

MICROWAVE OVENS	Electrical Ratings and Maximum Connected Load		
	@ 220-240 Volts 50Hz		
	Amperes	Watts	MHz
CM109 – CM209	13.9	3200	2450

2.2.1 Location

The product serial number plate is located on the bottom profile trim.

2.2.2 Model & Serial Number

The numbers printed on the plate contains the following information:

- Model
- Serial Number
- Electrical ratings

Components Specifications

2.3.1	Heating Elements	Volts	Freq.	Watts	Note
	Grill	230	--	1500	
	Ring (if present)	230	--	1500	

2.3.2	Motors	Volts	Freq.	Watts	Note
	Convection Fan	220-240	50/60	22	CL H
	Cooling Fan	220-240	50/60	30	CL H
	Rotating Plate	230	50	4	

2.3.3	Electric Components	Volts	A	Watts	Note
	Door Lock Motor Switch	250	16	--	
	Lamp	230	--	25	
	Safety Thermostat s	250	16	--	T 210
	Capacitor H.V.	2100VAC	16	--	0.7 μF ±3% T85
	Transformer H.V.	230V			50 Hz CL 220
	NTC Probe Temperature	5V	--	--	
	Magnetron	1000W			2450MHz
	Filter RLC	250			50/60 Hz 16A/40°C
	Fuse	5,7kV	1		L5KV
	Diode	12kV	500mA		





- **ELECTRONIC CONTROL.** The control consists of a main power board and Full Touch Keyboard.
- **COOKING MODE & TEMPERATURE SELECTION.** The Microwave oven is full touch control for the set cooking modes and set temperature.
- **TEMPERATURE SENSOR.** There is one NTC sensor, fixed on the top of the internal cavity.
- **MAGNETRON.** A magnetron is placed on the top of appliance, it emits the necessary microwaves to cook food.
- **HEATING ELEMENTS.** Several heaters are available in multifunction ovens. They are combined together in different ways, depending on the selected mode, but the maximum power never overtakes 3200W.
 - GRILL ELEMENT 1500W at 230V.
 - RING ELEMENT 1500W at 230V.
- **CONVECTION FAN.** This fan is available in multifunction cavities; it works always at the same speed in all convection modes, dehydrate.
- **COOLING FAN SYSTEM.** A cooling fan keeps the internal parts temperature within acceptable values.
- **OVEN LIGHTS.** Halogen 230V lamp. They turn on when a cooking mode starts.
- **DOOR MICRO SWITCH SYSTEM.** The door Micro switches are safety devices. Their internal contact allows to the Microwave to start only when the door is closed.

IMPORTANT: The MANUAL TEST procedure can be activated only after power on.







To enter in the MANUAL TEST follow the following procedure:

























1.

a) **NEW CONTROL BOARD (unprogrammed):** When the oven is plugged in to the power the language mode appears to the display Holding simultaneously the  &  the control switch in the Manual Test procedure (its takes about 30 seconds to enter in this mode).

b) **CONTROL BOARD (programmed):** When the oven is plugged in to the power the DEMO mode appears to the display, PRESS  to exit than hold simultaneously the  &  the control switch to the language mode, after holding simultaneously the  &  the control switch in the Manual Test procedure (its takes about 30 seconds to enter in this mode).



2. All the icons & keys on the control panel must turn on, on the display the lock icon is illuminated while the clock and temperature digits have to shows “”, now the operator has a time of 2-3 sec. to verify that all the lights are turned on;
NOTE: after few seconds without any operating on the control only  is lighted.
3. Holding the  key to start with the functions screening starting from light until the last icon / features of traditional cooking, once pressed the icons should be switch in red color and the power must take action immediately in every cooking mode.
4. Check (by amperometer or wattmeter) the power in the function selected and proceed to the next function until the verifying the change in light of the selected icon.
5. During the traditional coking functions the following parameters should be showed:
 - 1) Hold  key (Ring): preset 165°C; Verify the power (1500W);
 - 2) Hold  key Ring + Grill: preset 210°C; Verify the power (3000W);
 - 3) Hold  key Convection Grill: preset 165°C; Verify the power (1500W);

- 4) Hold  key Grill: preset MAX; Verify the power of ring element (1500W);
 - 5) The following icons have to be turned on “cooking time” , “end cooking time” , bell , and  & .
6. During the microwave cooking functions the following parameters should be showed:
- 1) Hold  key the display shows “00:00”; Verify the power (1500W); Rotating dish ON
 - 2) Hold  key the display shows “PANE VERDURA CARNE PESCE”; Verify the power (1500W); Rotating dish ON
 - 3) Hold  key the display shows “900W” (UP) & “00:00” (LOW); Verify the power (1500W); Rotating dish ON
 - 4) Hold  key the display shows “450W” (UP) & “00:00” (LOW); Verify the power (3000W); Rotating dish ON
 - 5) Hold  key the display shows “450W” (UP) & “00:00” (LOW); Verify the power (3000W); Hold  key the display shows “165°C”, hold  key again to confirm, the  &  icons turn ON ; Rotating dish ON
 - 6) Hold  key the display shows the recipes window,
 - a. hold  key selecting “**Impostate**”, hold  to confirm it,
 - b. hold  key selecting “**Pane pizza primi piatti**”,
 - c. hold  selecting “**Fresco**” hold  to confirm it,
 - d. hold  selecting “**Risotto alla pescatora**”, hold  to confirm it,
 - e. now the cooking starts; Verify the power (1500W); Rotating dish ON.
 - f. finally hold  to END cooking.

At the end of servicing the microwave energy emission measurement must be operated see MEASUREMENT OF ENERGY EMISSION (section 1.2).

NOTE: During the manual test the cooling fan must operate.

Variant with oven light turned on by 'opening the door (if present):

During last function (door closed), the internal light have to be turned OFF by  key, than it should turned ON by the door opening and turned OFF by closing.

Faults

Temperature sensor disconnected or shorted.

**N°
Err 1**

Door micro switch open

Err 2

Electronic boards over temperature (more than 85°C)

Err 3

Electronic boards sensor temperature damaged

Err 4

Flexible key board damaged

Err 5

2.7.1 Interlock Mechanism

The door lock mechanism is a device which has been specially designed to eliminate completely microwave activity when the door is opened during cooking and thus to prevent the danger resulting from the microwave leakage.

2.7.2 Safety Thermostats

This appliance is built with three bi-metal mechanical thermostats. The thermostats are mounted in contact with the metal sheet .

The function of the safety thermostat is to protect the of the oven from overheating in the event of a malfunction of the cooling fan.

In the event that the temperature is rising over the limits, the thermostat will switch mechanically from off position to on position and all of the heating elements will be cut off from the power. All of the electronics will be still powered.

The reset is automatic when the cooling fan was replaced or the cooling fan problem was solved and the temperature is in the right functioning parameters.

NOTE: A MICROWAVE ENERGY LEAKAGE TEST MUST ALWAYS BE PERFORMED WHEN THE UNIT IS SERVICED FOR ANY REASON.

BEFORE TOUCHING any parts of the oven, always remove the power plug from the outlet.

For about 60 seconds after the oven stops, an electric charge remains in the high voltage capacitor. When replacing or checking, you must wait to permit the capacitor discarding.

Code	Error	Description	Possible Cause	Corrective Action	section
ERROR 1	Temperature sensor disconnected or shorted.	The control reads out of range values.	Bad connection Temperature sensor broken.	Check the connectors and the harness Replace the sensor	<u>7.14</u>
ERROR 2	Door micro switch open	Hardware failure.	Door micro switch broken	Replace the door micro switch	<u>7.9</u>
ERROR 3	Electronic boards over temperature (more than 85°C)	Overheating of the internal parts.	Cooling fan broken	Replace the cooling fan	<u>7.2</u>
			Bad connections between cooling fan and electronics.	Check connections	--
			Air flow through the cooling channel is not sufficient.	Check proper installation. The slot between the control panel and the door must be free.	--
			Defective cooling fan relay on main power board	Replace the electronic board.	<u>7.18</u>
			Faulty NTC sensor on main power board	Replace the electronic board.	<u>7.18</u>
ERROR 4	Electronic boards sensor temperature damaged	Hardware failure.	--	Replace the electronic board.	<u>7.18</u>
ERROR 5	Flexible key board damaged	Hardware failure.	--	Replace the electronic board.	<u>7.18</u>

Microwave oven doesn't work

NOTE: A MICROWAVE ENERGY LEAKAGE TEST MUST ALWAYS BE PERFORMED WHEN THE UNIT IS SERVICED FOR ANY REASON.

BEFORE TOUCHING any parts of the oven, always remove the power plug from the outlet.

For about 60 seconds after the oven stops, an electric charge remains in the high voltage capacitor. When replacing or checking, you must wait to permit the capacitor discarding.

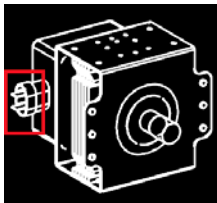
Anomaly	Possible Cause	Corrective Action	section
Oven does not run No power supply	Inserting many plugs into one outlet and using them at the same time (blown fuse or breaker)	Avoid using other electrical appliances when you use the microwave oven. Replace the fuses	--
	Short circuit	Find the short circuit and remove it. Check internal connections (short circuit, interruptions, etc..)	--
	Microwave oven plug is not inserted tightly.	Insert microwave oven plug securely.	--
Oven does not run Power supply ok.	Door switches damaged	Check for continuity of the switch with an Ohm-meter	--
	Connections to the Electronic Control	Replace the Power Board	7.18
		Check the main fuse on Electronic Board	--
	Magetron is damaged 	1. Measure the resistance. (Ohm-meter scale: Rx1) • Filament terminal (Wire leads are removed) Normal: Less than 1 ohm 2. Measure the resistance. (Ohm-meter scale: Rx1000) • Filament to chassis (Wire leads are removed) Normal readings: Infinite	7.8
Fuse is interrupted	Check continuity of fuse by ohm - meter	7.19	

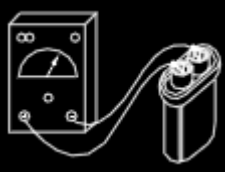
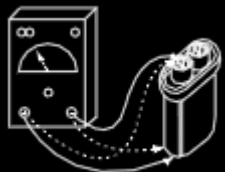
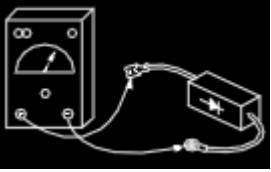
<p>High voltage Transformer is damaged</p>	<p>Measure the resistance (Wire leads removed): With an ohm-meter on R x1 scale.</p> <ul style="list-style-type: none"> a. Primary winding; b. Secondary winding; 	<p>Normal readings:</p> <ul style="list-style-type: none"> a. Approx. 2 ohm. b. Approx. 170 ohms. 	
	<p>Measure the resistance (Wire leads removed): (Ohm-meter scale: Rx10000)</p> <ul style="list-style-type: none"> a. Primary winding to ground; b. Filament winding to ground; 	<p>Normal readings:</p> <ul style="list-style-type: none"> a. Infinite ohms. b. Infinite ohms. 	<u>7.12</u>
<p>High Voltage capacitor damaged</p>	 <p>Measure the resistance: Terminal to terminal (Wire leads removed) (Ohm-meter scale: Rx1000)</p>	<p>Normal reading: Momentarily indicates several ohms, and then gradually returns to infinite ohms.</p> <p>Abnormal reading: Indicates continuity or infinite ohms from the beginning.</p>	<u>7.13</u>
	 <p>Measure the resistance: Terminal to case (Wire leads removed) (Ohm-meter scale: Rx1000)</p>	<p>Normal readings: Infinite.</p> <p>Abnormal reading: Indicates continuity.</p>	
<p>High Voltage diode damaged</p> <p>NOTE : Some inexpensive meters may indicate infinite</p>		<p>Normal readings: continuity.</p> <p>Abnormal reading: Infinite.</p>	

	<p>resistance in both direction.</p>	<p>Measure the continuity (Wire leads removed): Forward (Ohm-meter scale: Rx10000)</p>		
		<p>Measure the continuity (Wire leads removed): Reverse (Ohm-meter scale: Rx10000)</p>	<p>Normal readings: Infinite.</p> <p>Abnormal reading: continuity.</p>	<p><u>7.16</u></p>
	<p>Safety Thermostat damaged</p>	<p>Check for continuity of the thermostat's contact with an Ohm-meter (Wire leads removed)</p>	<p><u>7.11</u></p>	

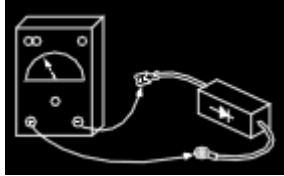

Cooling Fan Problems

NOTE: A MICROWAVE ENERGY LEAKAGE TEST MUST ALWAYS BE PERFORMED WHEN THE UNIT IS SERVICED FOR ANY REASON.

BEFORE TOUCHING any parts of the oven, always remove the power plug from the outlet.

For about 60 seconds after the oven stops, an electric charge remains in the high voltage capacitor. When replacing or checking, you must wait to permit the capacitor discarding.

Anomaly	Possible Cause	Corrective Action	section
Fan does not run No power supply	Bad connection Relay on power Board.	Check the connectors and the harness. Replace the Control Board	<u>7.18</u>
Fan does not run Power supply ok.	Blocked rotor	Replace fan	<u>7.2</u>
	Burned coil	Replace fan	<u>7.2</u>
Noisy fan	Lose attachment screws on cooling assembly	Check attachment screws on cooling assembly or replace fan	<u>7.2</u>
The cooling fan is always on	The control is measuring a high temperature inside the cavity	Check all the connections between the sensor and Control Board.	--
		Check the probe temperature sensor connection .	--

Convection Fan Problems

NOTE: A MICROWAVE ENERGY LEAKAGE TEST MUST ALWAYS BE PERFORMED WHEN THE UNIT IS SERVICED FOR ANY REASON.

BEFORE TOUCHING any parts of the oven, always remove the power plug from the outlet.

For about 60 seconds after the oven stops, an electric charge remains in the high voltage capacitor. When replacing or checking, you must wait to permit the capacitor discarding.

Anomaly	Possible Cause	Corrective Action	section
Fan does not run No power supply	Bad connection Relay of convection fan not switching	Check the connectors and the harness Replace the Control Board.	<u>7.18</u>
Fan does Not run Power supply ok.	Blocked rotor	Replace fan	<u>7.4</u>
	Burned coil	Replace fan	<u>7.4</u>
Noisy fan	Lose attachment screws on cooling assembly	Check attachment screws Check nut on working fan for tightness or replace it.	<u>7.4</u>

Oven Light Problems

NOTE: A MICROWAVE ENERGY LEAKAGE TEST MUST ALWAYS BE PERFORMED WHEN THE UNIT IS SERVICED FOR ANY REASON.

BEFORE TOUCHING any parts of the oven, always remove the power plug from the outlet.

For about 60 seconds after the oven stops, an electric charge remains in the high voltage capacitor. When replacing or checking, you must wait to permit the capacitor discarding.

<i>Anomaly</i>	<i>Possible Cause</i>	<i>Corrective Action</i>	<i>section</i>
The Oven lights are always OFF. No power supply.	Bad connection The light not switching	Check the connectors and the harness Replace the Power Board	<u>7.18</u>
The Oven lights are always OFF. Power supply is ok.	Lamps are burned out.	Replace lamp bulb.	<u>7.25</u>
The Oven lights are always ON.	Bad connection Realy contact is broken or in short circuit.	Check the connectors and the harness Replace the Power Board	<u>7.18</u>
	Door micro switch (If present) is shorted	Replace the Micro Switch	<u>7.9</u>

NOTE: A MICROWAVE ENERGY LEAKAGE TEST MUST ALWAYS BE PERFORMED WHEN THE UNIT IS SERVICED FOR ANY REASON.

BEFORE TOUCHING any parts of the oven, always remove the power plug from the outlet.

For about 60 seconds after the oven stops, an electric charge remains in the high voltage capacitor. When replacing or checking, you must wait to permit the capacitor discarding.

Anomaly	Possible Cause	Corrective Action	section
The display is always dark, the latch at power up doesn't work	The power supply is not working.	Check and eventually replace the Display Board.	<u>7.18</u>

Door Hinge Problems

NOTE: A MICROWAVE ENERGY LEAKAGE TEST MUST ALWAYS BE PERFORMED WHEN THE UNIT IS SERVICED FOR ANY REASON.

BEFORE TOUCHING any parts of the oven, always remove the power plug from the outlet.

For about 60 seconds after the oven stops, an electric charge remains in the high voltage capacitor. When replacing or checking, you must wait to permit the capacitor discarding.

Anomaly	Possible Cause	Corrective Action	section
The door does not close or there is not sealing between door and gasket	Hinges system is broken or damaged	Replace the units	7.15
	The door gasket is broken or damaged	Replace the units	7.10

Bad Cooking Performance

NOTE: A MICROWAVE ENERGY LEAKAGE TEST MUST ALWAYS BE PERFORMED WHEN THE UNIT IS SERVICED FOR ANY REASON.

BEFORE TOUCHING any parts of the oven, always remove the power plug from the outlet.

For about 60 seconds after the oven stops, an electric charge remains in the high voltage capacitor. When replacing or checking, you must wait to permit the capacitor discarding.

Anomaly	Possible Cause	Corrective Action	section
Bad performance	Heating elements not working	Check the connection of the heating elements	--
		If there is not power on the heating elements check relays. If the electronic control relay not switching replace the units.	7.18
		If there is not power on the heating elements check safety thermostat. If the thermostat not switching replace the units	7.11
		Check the power on the heating elements and replace the elements if needed.	7.5 7.6
		Check the protection fuse near Power Board and replace it if needed.	7.12
	Convection fan not working properly	See the convection fan problem	4.4
Uneven cooking	There is not sealing between door and gasket	The hinges system or the door gasket are damaged. Replace the units	7.15 7.10
		Inconsistent intensity of microwave by their characteristics.	--



1. Disconnect the power supply cord.
2. Open the door.
3. Remove the screws shown in the pictures.
4. Pull off the oven.
5. Remove the oven by using the lateral handles.

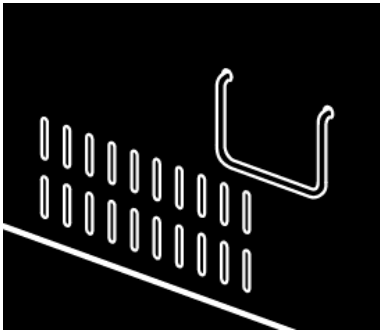

Lateral Handles (if present)



Cooling fan motor substitution

1. Disconnect the power supply cord and remove the Oven from the cabinet.
2. Remove the upper cover.
3. Disconnect the terminals on the fan.
4. Remove the five screws on the fan and remove the fan.
5. Replace the new one with the screws and connect the terminals.
6. The connections must not be loose.
7. Reinstall the Oven into the cabinet.
8. Reconnect the power supply cord after the Oven is installed.
9. Run the Oven and check all functions and microwave emission ([section 1.2](#)).

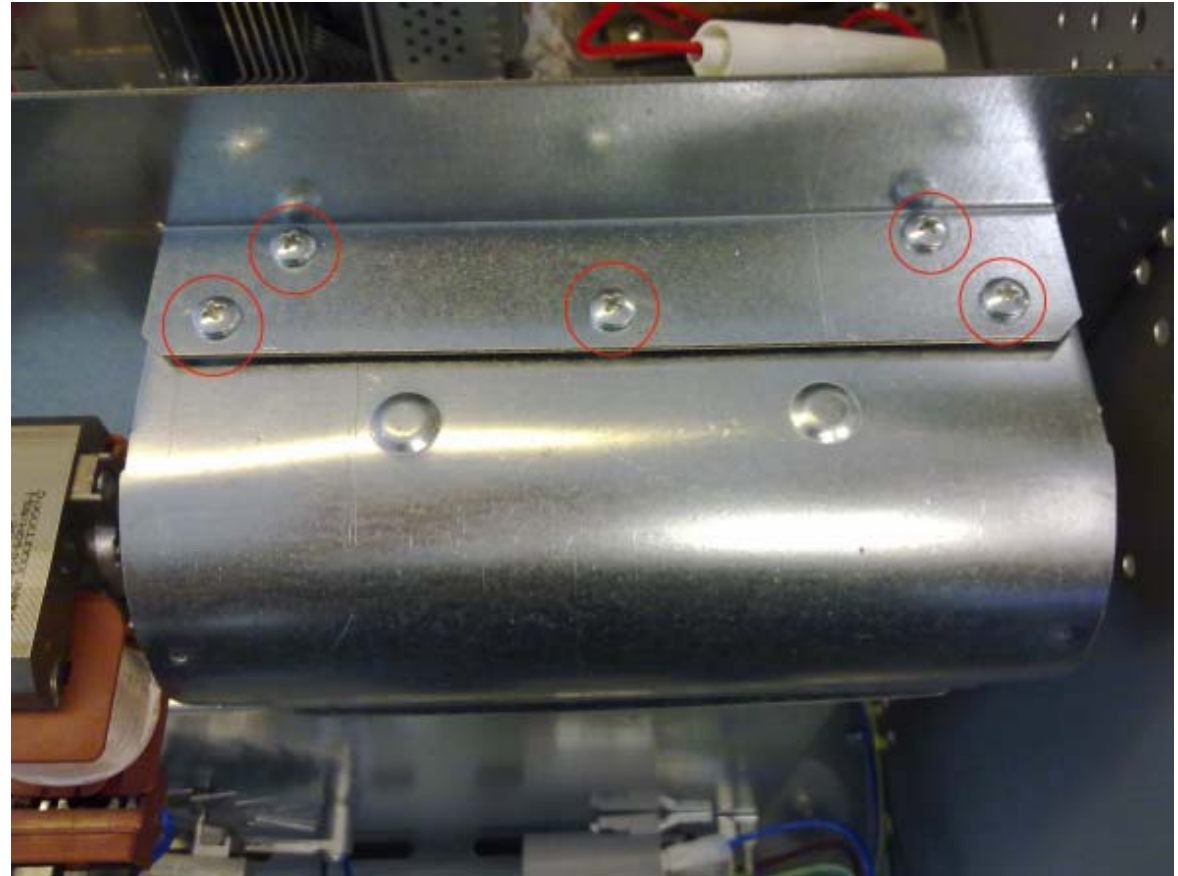

To Remove Door

1. Open the door completely.
2. Lift up the hinge bracket (1) from the arms (2) .
3. Hold the door firmly on both sides using both hands and close the door, then remove it .
4. Hold firmly; the door is heavy.
5. Place the door in a convenient location.

**To Replace Door**

1. Insert the upper arms (2) of both hinges into the slots. The recesses (3) must hook on the lips (4).
2. Move the hinge brackets (1) back down into position.
3. Close and open the door slowly to assure that it is correctly and securely in place.



Convection fan motor substitution

1. Disconnect the power supply cord and remove the Oven from the cabinet.
2. Remove the upper, rear and lateral covers.
3. Disassemble the brackets by removing their three screws each (fig.1).
4. Remove the back support by removing the last two screws on the top (fig.1).
5. Remove the fan blade by using a 10mm socket (fig.2), then remove the fan damaged by its three external screws (fig.1).
6. Disconnect the terminals on the fan in the rear side.
7. Mount the new fan motor with the screws and then mount also the fan blade.
8. Replace the back support.
9. Connect the terminals.
10. The connections must not be loose.
11. Reinstall the Oven into the cabinet.
12. Reconnect the power supply cord after the Oven is installed.
13. Run the Oven and check all functions and microwave emission ([section 1.2](#)).



Figure 2

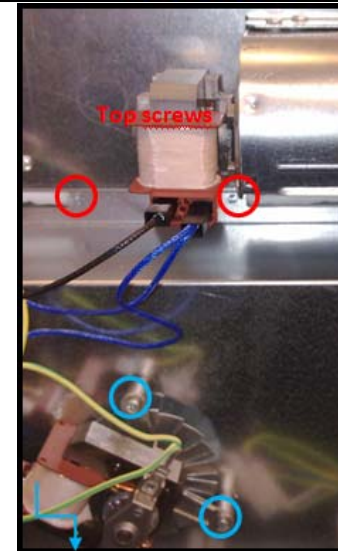
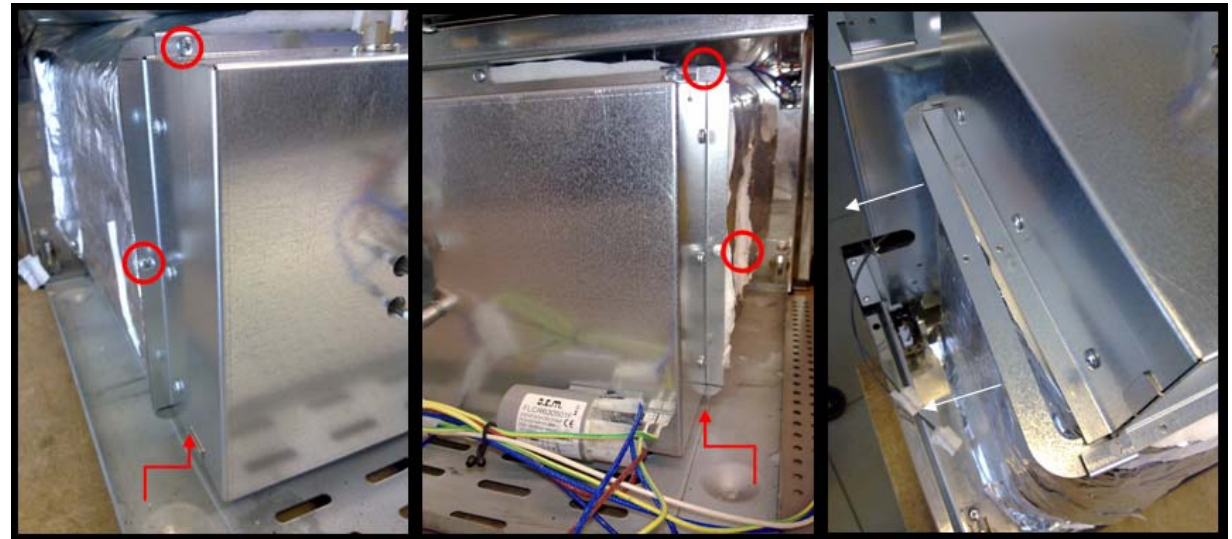

Figure 1

Ring element substitution

1. Disconnect the power supply cord and remove the Oven from the cabinet.
2. Remove the upper, rear and lateral covers.
3. Disassemble the brackets by removing their three screws each (fig.1).
4. Remove the back support by removing the last two screws on the top (fig.1).
5. Remove ring element damaged by its screws (fig.2).
6. Disconnect the terminals on the heating element in the rear side.
7. Mount the new ring heating element with the screws.
8. Replace the back support.
9. Connect the terminals.
10. The connections must not be loose.
11. Reinstall the Oven into the cabinet.
12. Reconnect the power supply cord after the Oven is installed.
13. Run the Oven and check all functions and microwave emission ([section 1.2](#)).

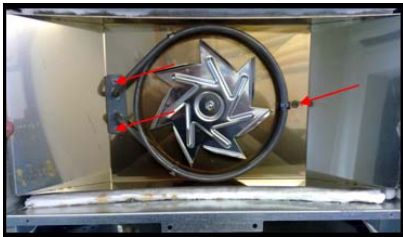

Figure 2

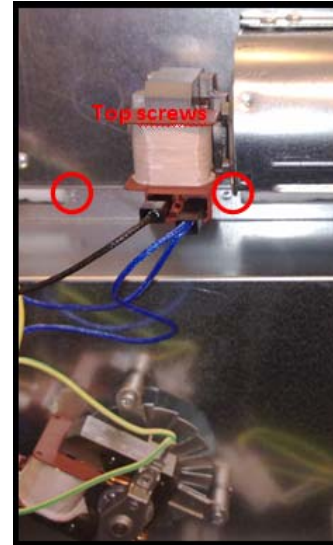
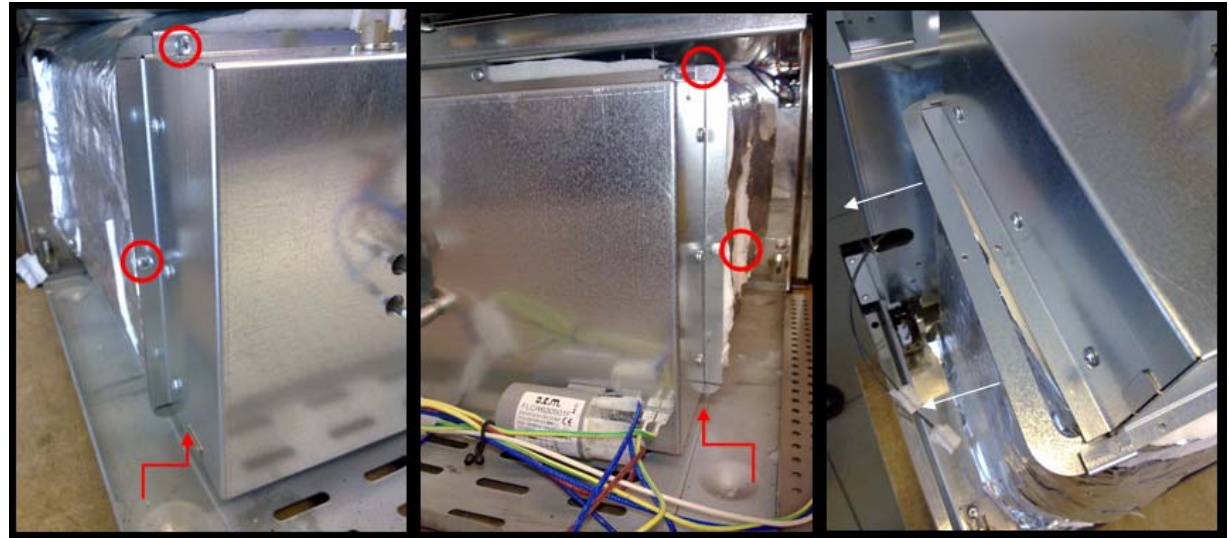

Figure 1

Grill element substitution

1. Disconnect the power supply cord and remove the Oven from the cabinet.
2. Remove the upper cover.
3. Remove the internal component cover (fig 1) by its six screws.
4. Remove the probe from its location using a clamp make rounded the border to extract it.(fig.2).
5. Disconnect the terminals.
6. Unscrew the nuts (fig.2).
7. Than open the door to access to the heating element on the top of the cavity and unscrew the central screw (fig.3) to remove the element damaged.
8. Replace the new one by reversing the previous steps
9. Connect the terminals and insert the temperature probe, crushing the entrance to make oval it to prevent the escape.
10. The connections must not be loose.
11. Reinstall the Oven into the cabinet.
12. Reconnect the power supply cord after the Oven is installed.
13. Run the Oven and check all functions and microwave emission ([section 1.2](#)).

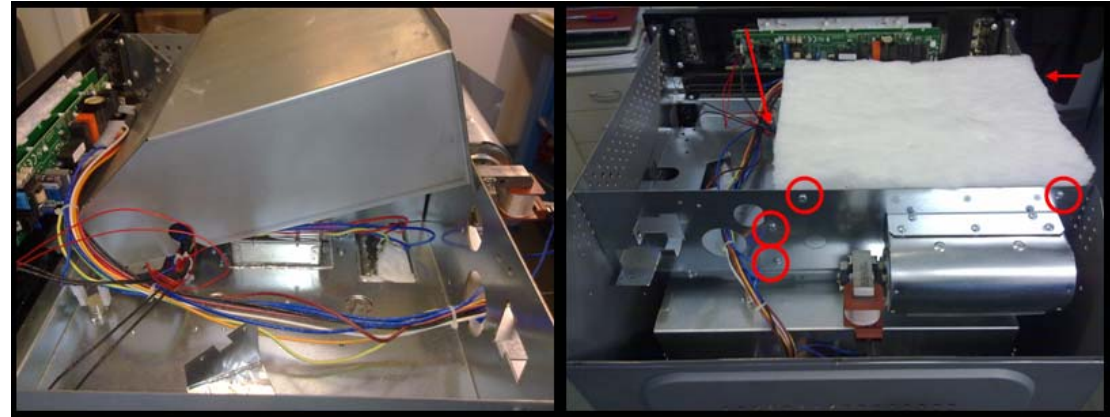

Figure 1

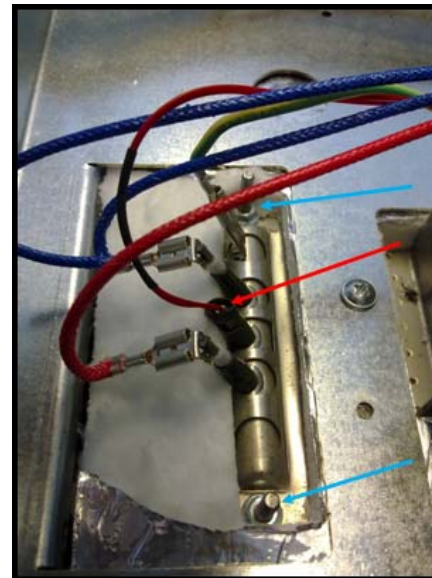

Figure 2



Figure 3

Rotating Dish Motor Substitution

1. Disconnect the power supply cord and remove the Oven from the cabinet.
2. Open the door and remove the plastic insert (fig1).
1. Put the oven with the door on a horizontal surface with a soft cloth to prevent scratching of the aesthetics.
3. Remove the upper, rear and lateral covers to access to dish motor.
4. Disconnect the terminals.
5. Remove the two screws to remove the motor damaged (fig.2).
6. Replace the new one by reversing the previous steps.
7. Connect the terminals.
8. The connections must not be loose.
9. Reinstall the Oven into the cabinet.
10. Reconnect the power supply cord after the Oven is installed.
11. Run the Oven and check all functions and microwave emission ([section 1.2](#)).



Figure 1



Figure 2

Magnetron Substitution

1. Disconnect the power supply cord and remove the Oven from the cabinet.
2. Remove the upper cover.
3. Remove the internal component cover (fig 1) by its six screws.
4. Remove the cooling channel (fig 2) by its two screws.
5. Disconnect from electrical supply magnetron
6. Remove the thermal cutout located on the top of Magnetron .(fig.3).
7. Now remove the Magnetron from oven structure unscrewing the four screws of its support.(fig.3).
8. Replace the new one by reversing the previous steps.

NOTE: When remove the magnetron, be sure to install the magnetron gasket in the correct position and be sure that the gasket is in good condition.

ATTENTION! not touch the magnetron antenna it can be damage.



9. Connect the electrical connector and reassemble the thermal cutout.
10. The connections must not be loose.
11. Reinstall the Oven into the cabinet.
12. Reconnect the power supply cord after the Oven is installed.
13. Run the Oven and check all functions and microwave emission ([section 1.2](#)).

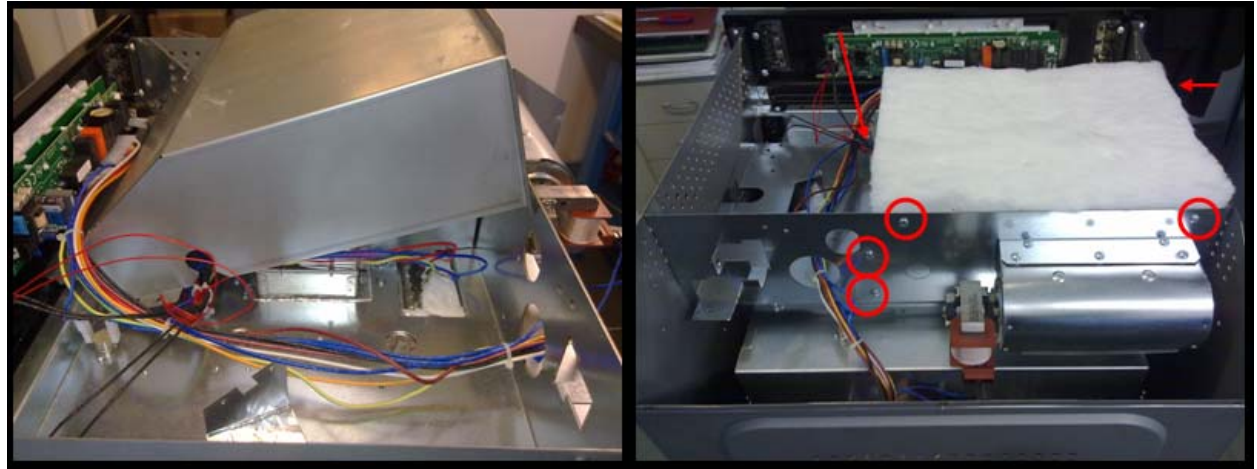

Figure 1

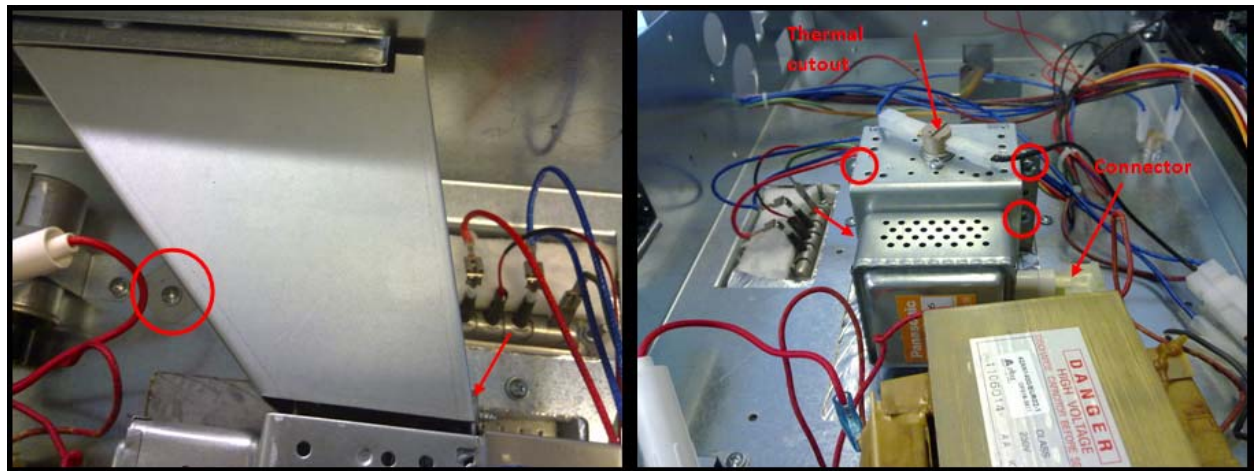

Figure 2

Figure 3

Lock door switch substitution

1. Disconnect the power supply cord and remove the Oven from the cabinet.
2. Remove the upper, rear and lateral cover .
3. Disconnect the terminals of micro switch.
4. Remove the plastic support performing the two movements as showed in the figure.
5. Replace the new one by reversing the previous steps.
6. Connect the terminals.
7. The connections must not be loose.
8. Reinstall the Oven into the cabinet.
9. Reconnect the power supply cord after the Oven is installed.
10. Run the Oven and check all functions and microwave emission ([section 1.2](#)).





1. Open door and pull out the gasket by hands unhooking it by its 4 hooks on the corners.
2. **THE GASKET IS MADE BY A SPACIAL MATERIAL FOR MICROWAVE AND IT MUST BE FITTED PROPERLY.**
3. Replace with a new one by reversing the previous steps.
4. Run the Oven and check all functions and microwave emission ([section 1.2](#)).



Safety thermostats substitution

1. Disconnect the power supply cord and remove the Oven from the cabinet.
2. Remove the upper cover.
3. Remove the internal components cover (fig 1) by its six screws.
4. Unscrew and disconnect the thermostat damaged (fig.2).
5. Replace the new one by reversing the previous steps.
6. Connect the terminals. The connections must not be loose.
7. Reinstall the Oven into the cabinet.
8. Reconnect the power supply cord after the Oven is installed.
9. Run the Oven and check all functions and microwave emission ([section 1.2](#)).

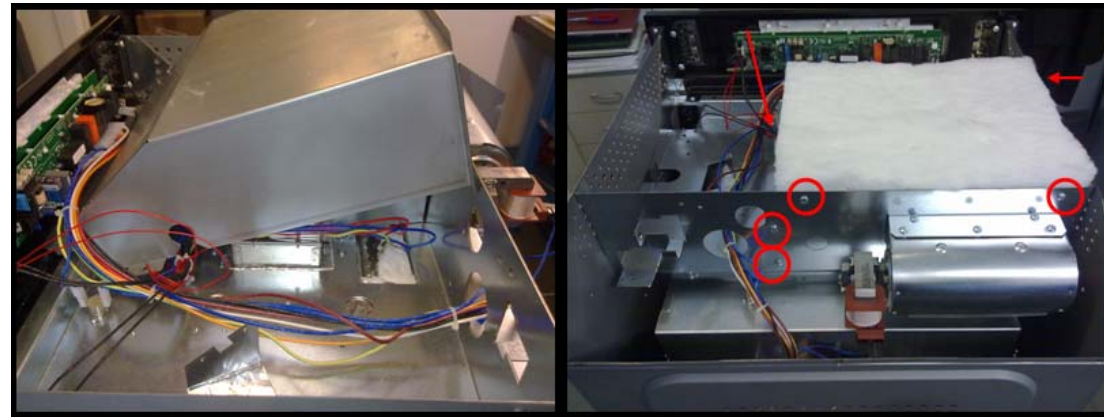

Figure1

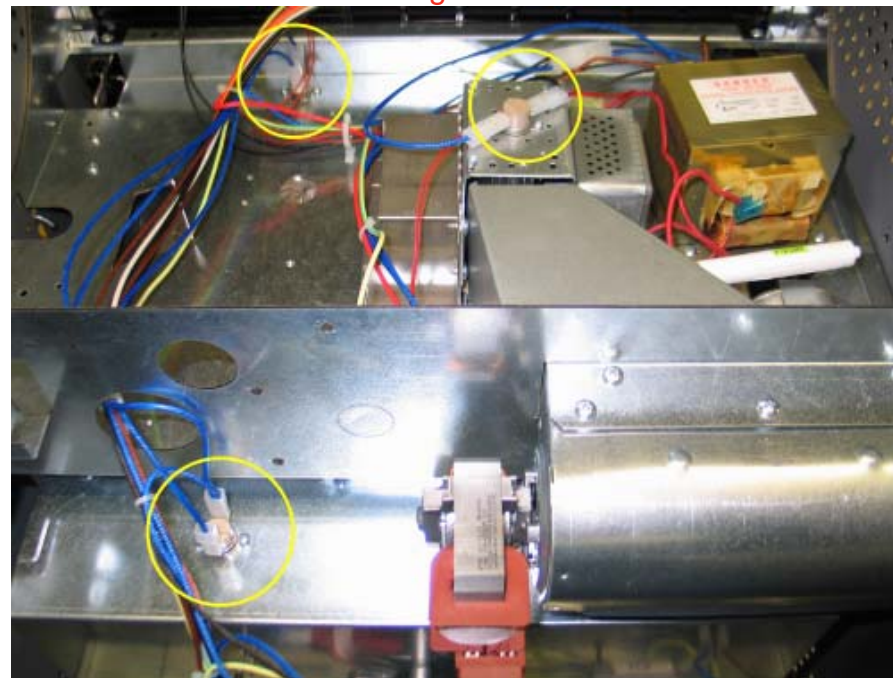

Figure 2



1. Disconnect the power supply cord and remove the Oven from the cabinet.
2. Remove the upper cover.
3. Remove the internal components cover (fig 1) by its six screws.
4. Disconnect the cable of transformer damaged and unscrew it by 4 base screws. (fig.2).
5. Replace the new one by reversing the previous steps.
6. Connect the terminals. The connections must not be loose.
7. Reinstall the Oven into the cabinet.
8. Reconnect the power supply cord after the Oven is installed.
9. Run the Oven and check all functions and microwave emission ([section 1.2](#)).

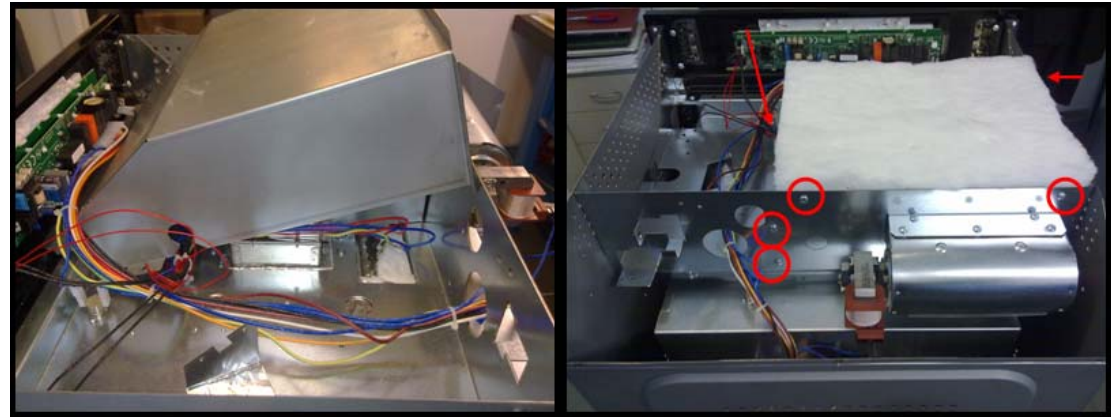

Figure1



Figure 2



1. Disconnect the power supply cord and remove the Oven from the cabinet.
2. Remove the upper cover.
3. Remove the internal components cover (fig 1) by its six screws.
4. Disconnect the cable of condenser damaged and unscrew it by 2 base screws. (fig.2).
5. Replace the new one by reversing the previous steps.
6. Connect the terminals. The connections must not be loose.
7. Reinstall the Oven into the cabinet.
8. Reconnect the power supply cord after the Oven is installed.
9. Run the Oven and check all functions and microwave emission ([section 1.2](#)).

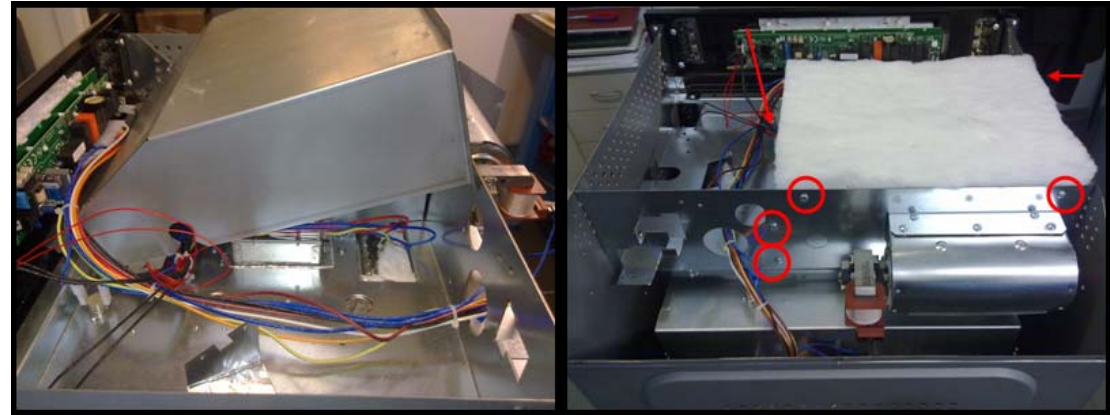

Figure1



Figure 2

Probe Temperature substitution

1. Disconnect the power supply cord and remove the Oven from the cabinet.
2. Remove the upper cover.
3. Remove the internal components cover (fig 1) by its six screws.
4. Remove the probe from its location using a clamp make rounded the border to extract it (fig.2).
5. Disconnect the terminals (fig.3).
6. Replace the new one by reversing the previous steps
7. Connect the terminals and insert the temperature probe, crushing the entrance to make oval it to prevent the escape.
8. The connections must not be loose.
9. Reinstall the Oven into the cabinet.
10. Reconnect the power supply cord after the Oven is installed.
11. Run the Oven and check all functions and microwave emission ([section 1.2](#)).

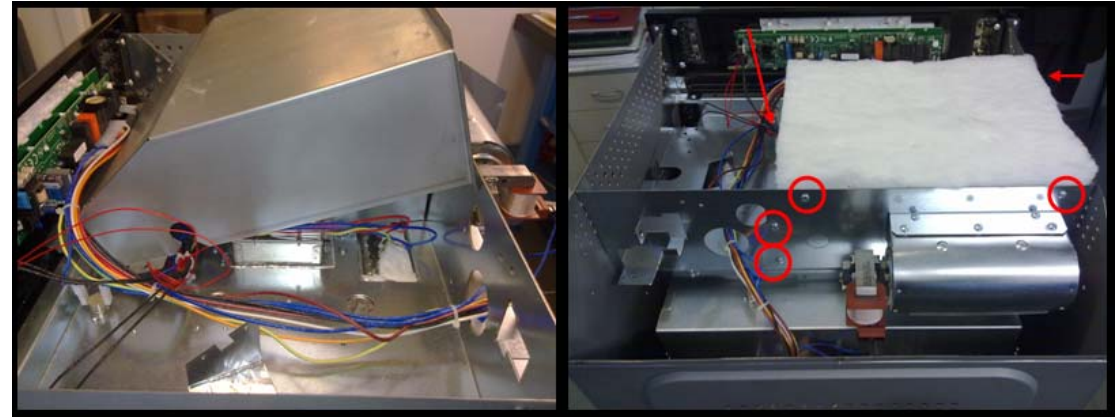

Figure1

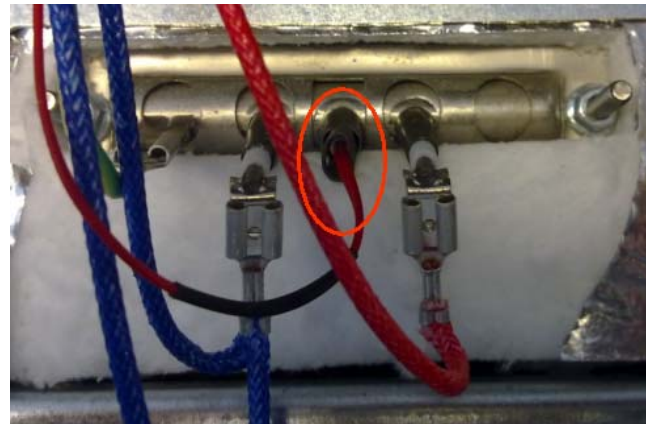

Figure 2

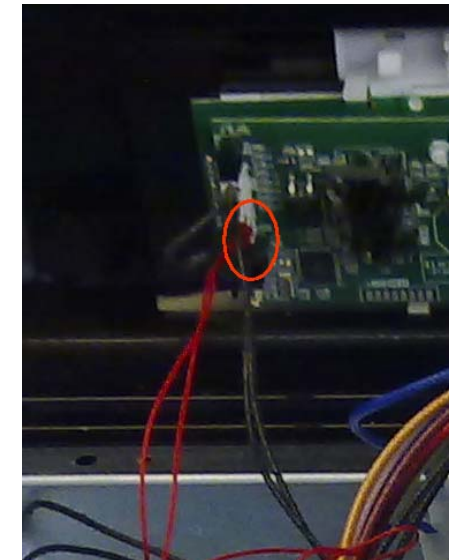

Figure 3

Door hinges substitution

1. Remove the Oven door following the [section 7.3](#).
2. Put the door on a flat surface with a soft cloth to prevent scratching of the aesthetics.
3. Unscrew the door external glass **A**.

Before to remove the hinges the hinge arm must be placed in the correct position following the steps (1 to 4) below.

4. Remove the hinges unscrewing its screws **B**.
5. To replace the hinges, reverse the previous steps.
6. To replace the aesthetic glass be sure that the door are in the right position keeping the glass centered.
7. Replace the Oven door following the [section 7.3](#).

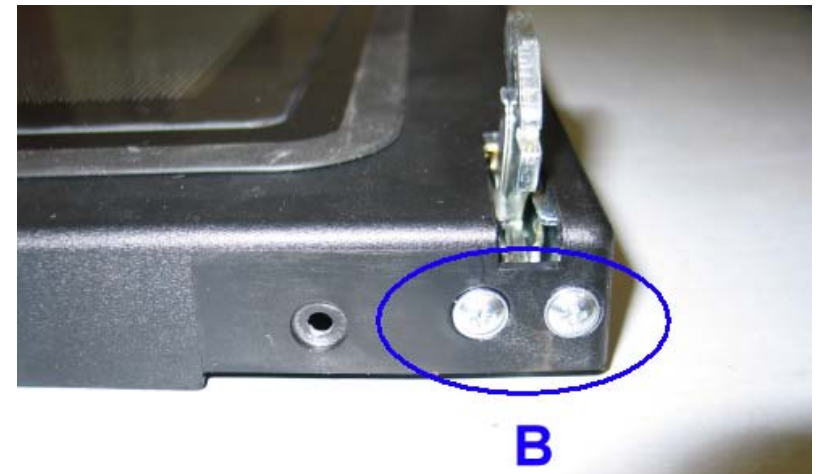
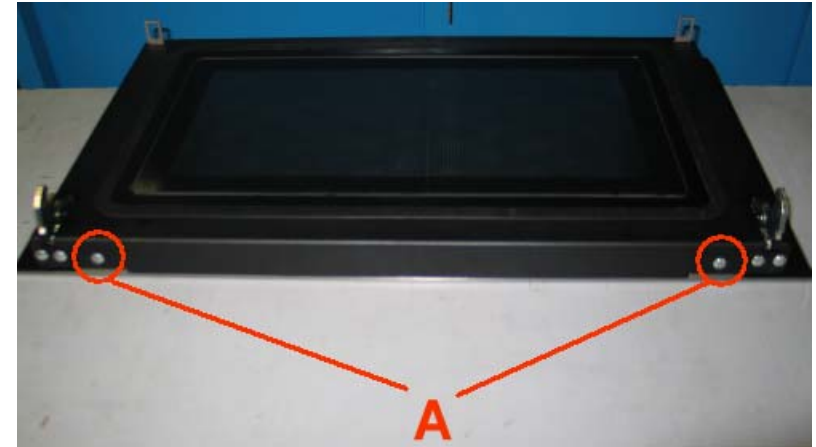



1. Disconnect the power supply cord and remove the Oven from the cabinet.
2. Remove the upper cover.
3. Remove the internal components cover (fig 1) by its six screws.
4. Disconnect the cable of diode damaged and unscrew it by its base screw. (fig.2)
5. Replace the new one by reversing the previous steps.
6. Connect the terminals. The connections must not be loose.
7. Reinstall the Oven into the cabinet.
8. Reconnect the power supply cord after the Oven is installed.
9. Run the Oven and check all functions and microwave emission ([section 1.2](#)).

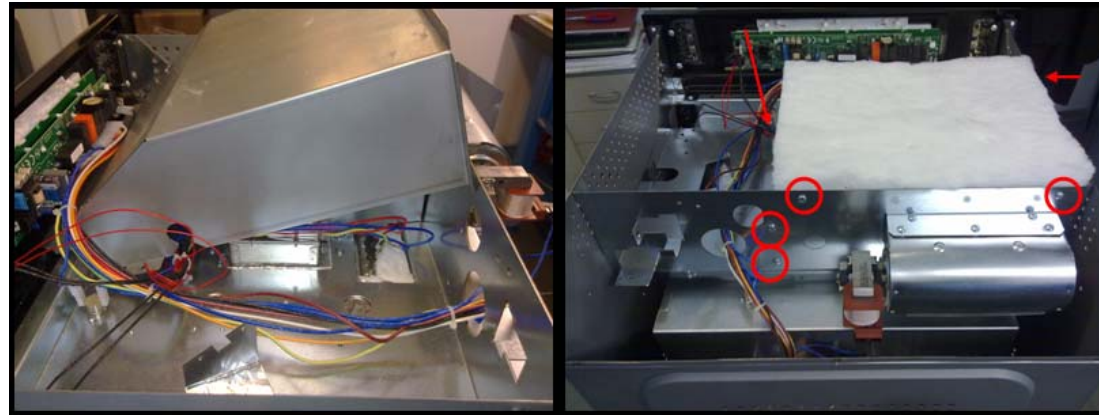

Figure1

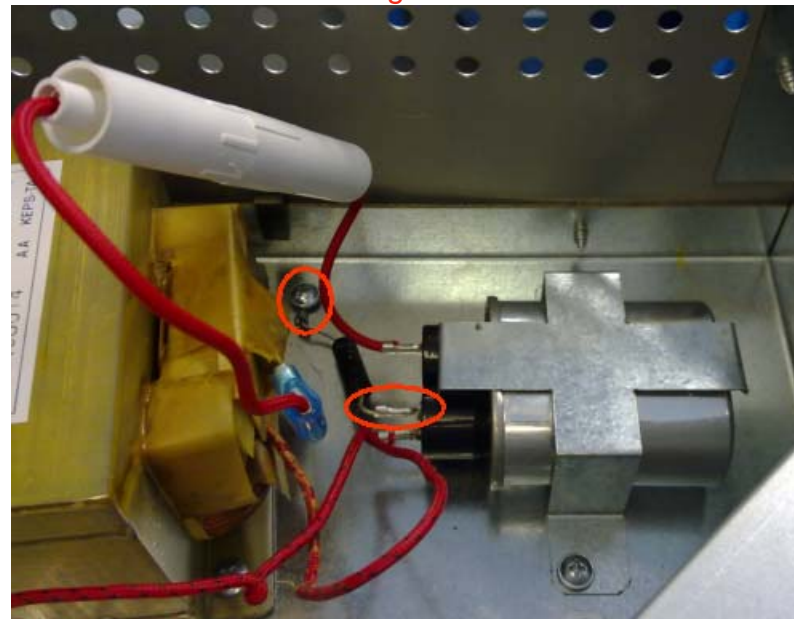

Figure 2



1. Disconnect the power supply cord and remove the Oven from the cabinet.
2. Remove the rear cover.
3. Disconnect the cable from filter damaged and unscrew it by its base screws. (fig.1)
4. Replace the new one by reversing the previous steps.
5. NOTE: for correct connection see the schematic label on filter.
6. Connect the terminals. The connections must not be loose.
7. Reinstall the Oven into the cabinet.
8. Reconnect the power supply cord after the Oven is installed.
9. Run the Oven and check all functions and microwave emission ([section 1.2](#)).



Figure 1

Electronic Control board substitution

1. Disconnect the power supply cord and remove the Oven from the cabinet.
2. Remove the upper cover.
3. Disconnect the bad Control Board and remove it by its four plastic bracket. (fig.1)
4. Replace the new one by reversing the previous steps.
5. Connect the terminals. The connections must not be loose.
6. Reinstall the Oven into the cabinet.
7. Reconnect the power supply cord after the Oven is installed.
8. Run the Oven and check all functions and microwave emission [\(section 1.2\)](#).



Fig.1





1. Disconnect the power supply cord and remove the Oven from the cabinet.
2. Remove the upper cover.
3. Remove the internal components cover (fig 1) by its six screws.
4. Open the fuse holder and remove the fuse damaged from the metal clamps (fig.2)
5. Replace the new one by reversing the previous steps.
6. Connect the terminals. The connections must not be loose.
7. Reinstall the Oven into the cabinet.
8. Reconnect the power supply cord after the Oven is installed.
9. Run the Oven and check all functions and microwave emission ([section 1.2](#)).

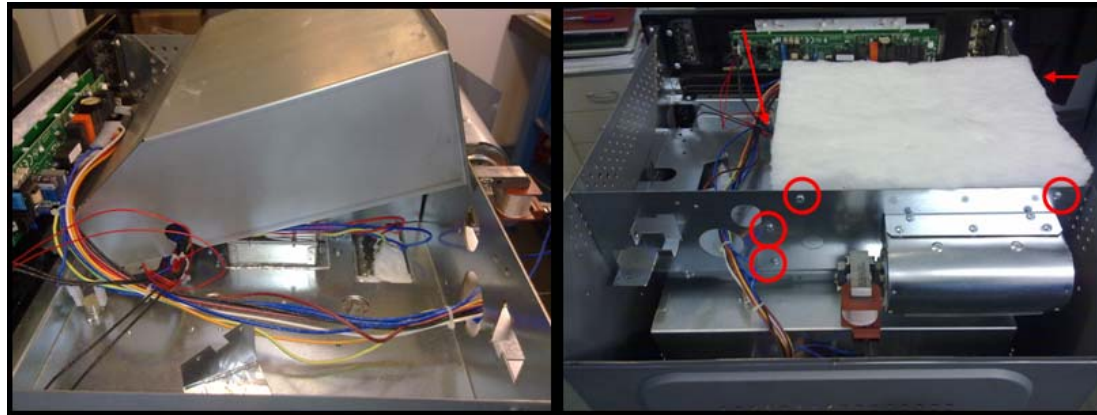

Figure1

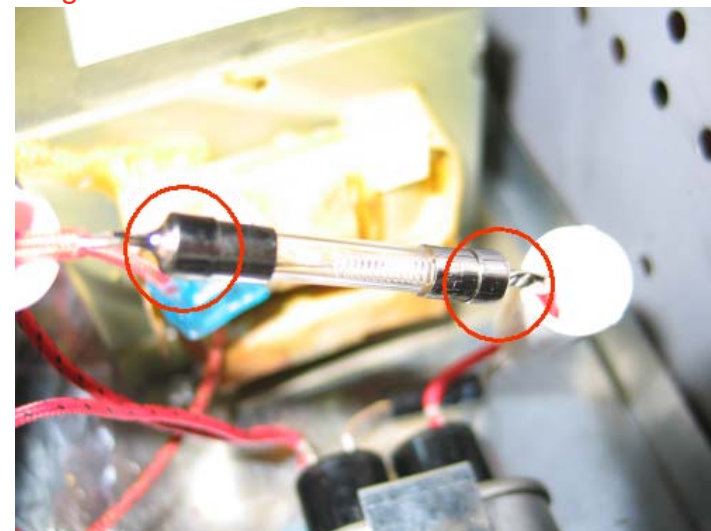
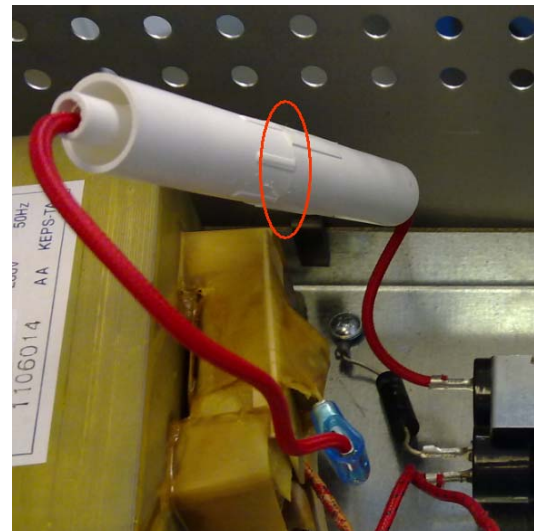

Figure 2

Door external glass substitution

1. Remove the door from the oven [section 7.3](#).
2. Put the door on a flat surface with a soft cloth to prevent scratching of the aesthetics.
3. Remove the external glass from the door unscrewing two screws on the corner ([fig.1](#)).
4. Remove also the handle by its two screws to mount it on the new glass ([fig.2](#)).
5. Replace the handle on the new aesthetic glass with its [support](#).
6. Assemble the glass and door keeping door in the middle of the glass.
7. Replace the Oven door following the [section 7.3](#).



Figure 1

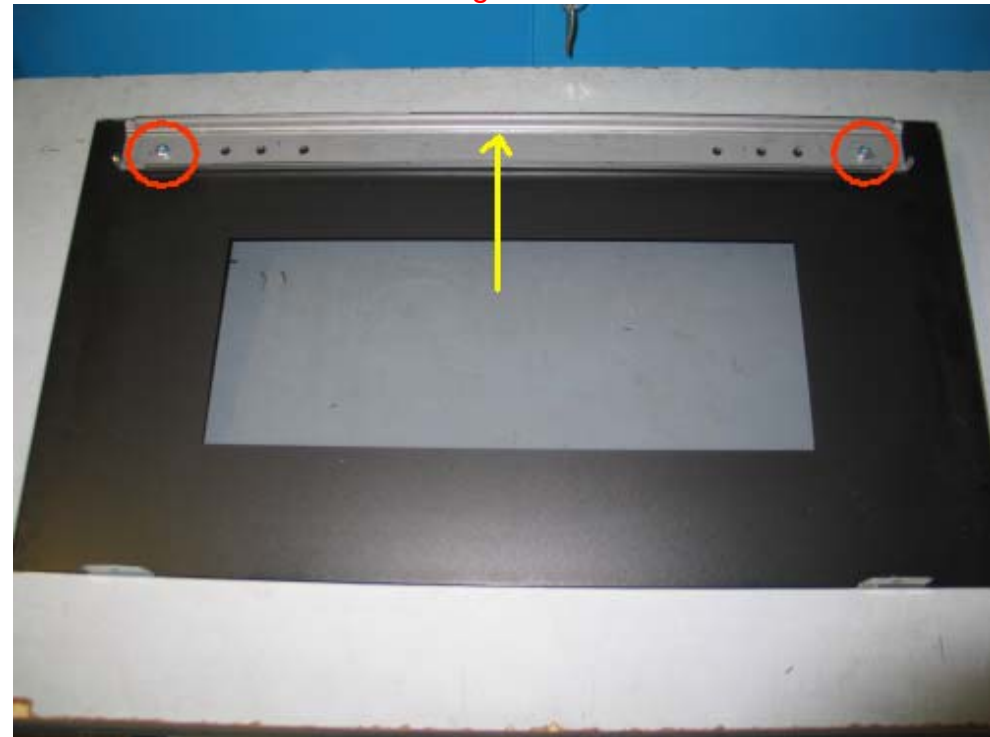

Figure 2

Door middle glass substitution

1. Remove the door from the oven [section 7.3](#).
2. Put the door on a flat surface with a soft cloth to prevent scratching of the aesthetics.
3. Remove the external glass from the door unscrewing two screws on the corner ([fig.1](#)).
4. Remove also the four brackets on the corner to replace the glass ([fig.2](#)).

When it is changed an middle glass you must be sure that the face whit (THERMO REFLECTIVE) printed it is towards the cavity ([fig.3](#)).

5. Assemble the glass and door keeping door in the middle of the glass.
6. Replace the Oven door following the [\(section 7.3\)](#).
7. Run the Oven and check all functions and microwave emission [\(section 1.2\)](#).



Figure 1



Figure 2



Figure 3

Door internal labyrinth glass substitution

1. Remove the door from the oven [section 7.3](#).
2. Put the door on a flat surface with a soft cloth to prevent scratching of the aesthetics.
3. Remove the external glass from the door unscrewing two screws on the corner ([fig.1](#)).
4. Remove also the four brackets on the corner to remove the middle glass.

When it is changed or removed an middle glass you must be sure that the face whit (THERMO REFLECTIVE) printed it is towards the cavity ([fig.2](#)).

5. To remove the labyrinth unscrew the six screws from its frame ([fig.3](#)).
6. Assemble the new one by previous reverse steps
7. Assemble the external glass and door keeping door in the middle of the glass.
8. Replace the Oven door following the [\(section 7.3\)](#).
9. Run the Oven and check all functions and microwave emission [\(section 1.2\)](#).



Figure 1



Figure 2



Figure 3

Door internal labyrinth glass gasket substitution

1. Remove the door from the oven [section 7.3](#).
2. Put the door on a flat surface with a soft cloth to prevent scratching of the aesthetics.
3. Remove the external glass from the door unscrewing two screws on the corner ([fig.1](#)).
4. Remove also the four brackets on the corner to remove the middle glass.

When it is changed or removed an middle glass you must be sure that the face whit (THERMO REFLECTIVE) printed it is towards the cavity ([fig.2](#)).

5. To remove the labyrinth unscrew the six screws from its frame, and dismount the gasket damaged by hand. ([fig.3](#)).
6. Assemble the new one by previous reverse steps.
7. Assemble the external glass and door keeping door in the middle of the glass
8. Replace the Oven door following the [\(section 7.3\)](#).
9. Run the Oven and check all functions and microwave emission [\(section 1.2\)](#).



Figure 1



Figure 2



Figure 3

Glass Control panel substitution

1. Disconnect the power supply cord and remove the Oven from the cabinet.
2. Remove the upper cover.
3. Remove the Control Board without disassembling the cable. ([section 7.18](#))
4. Substitute the glass damaged by removal of the four screws on metal brackets. ([fig.1](#))
5. Replace the new one by reversing the previous steps mounting also a new plastic control board brackets. ([fig.2](#))
6. Reinstall the Oven into the cabinet.
7. Reconnect the power supply cord after the Oven is installed.
8. Run the Oven and check all functions and microwave emission ([section 1.2](#)).



Fig.2

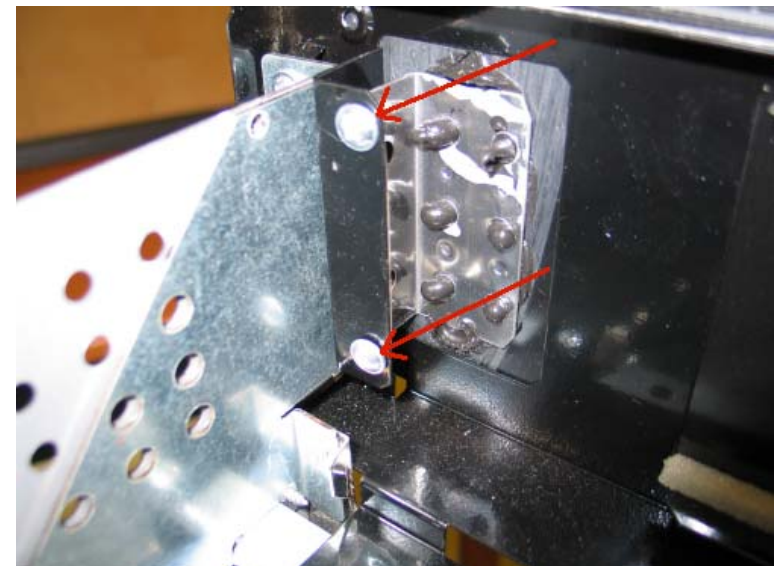

Fig.1



1. Disconnect the power supply cord and remove the Oven from the cabinet.
2. Remove the upper, rear and lateral cover .
3. Open the glass lens to access to bulb as showed **(fig. 1)**.
4. Replace the new one by reversing the previous steps.
5. The insulation around the lamp must be properly located, it must not cover the lamp cavity holes.
6. NOTE: The lens it must be in contact with cavity holes.
7. Reinstall the Oven into the cabinet.
8. Reconnect the power supply cord after the Oven is installed.
9. Run the Oven and check all functions and microwave emission ([section 1.2](#)).

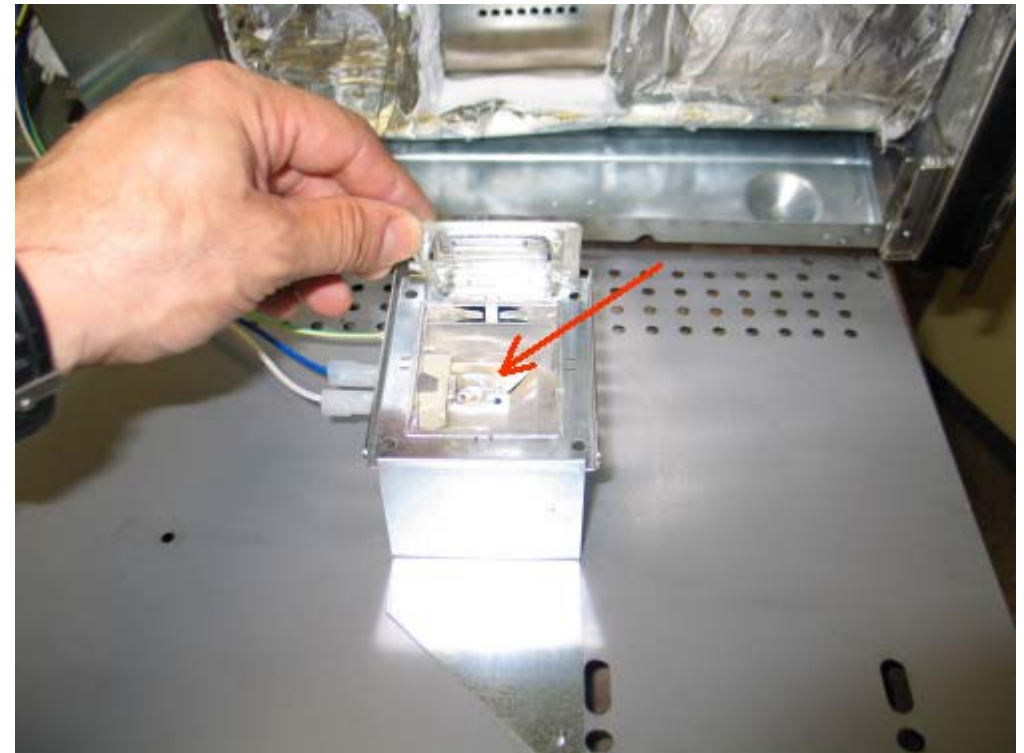

Figure 1