



CM471SS

Caple built in coffee machine



Technical information

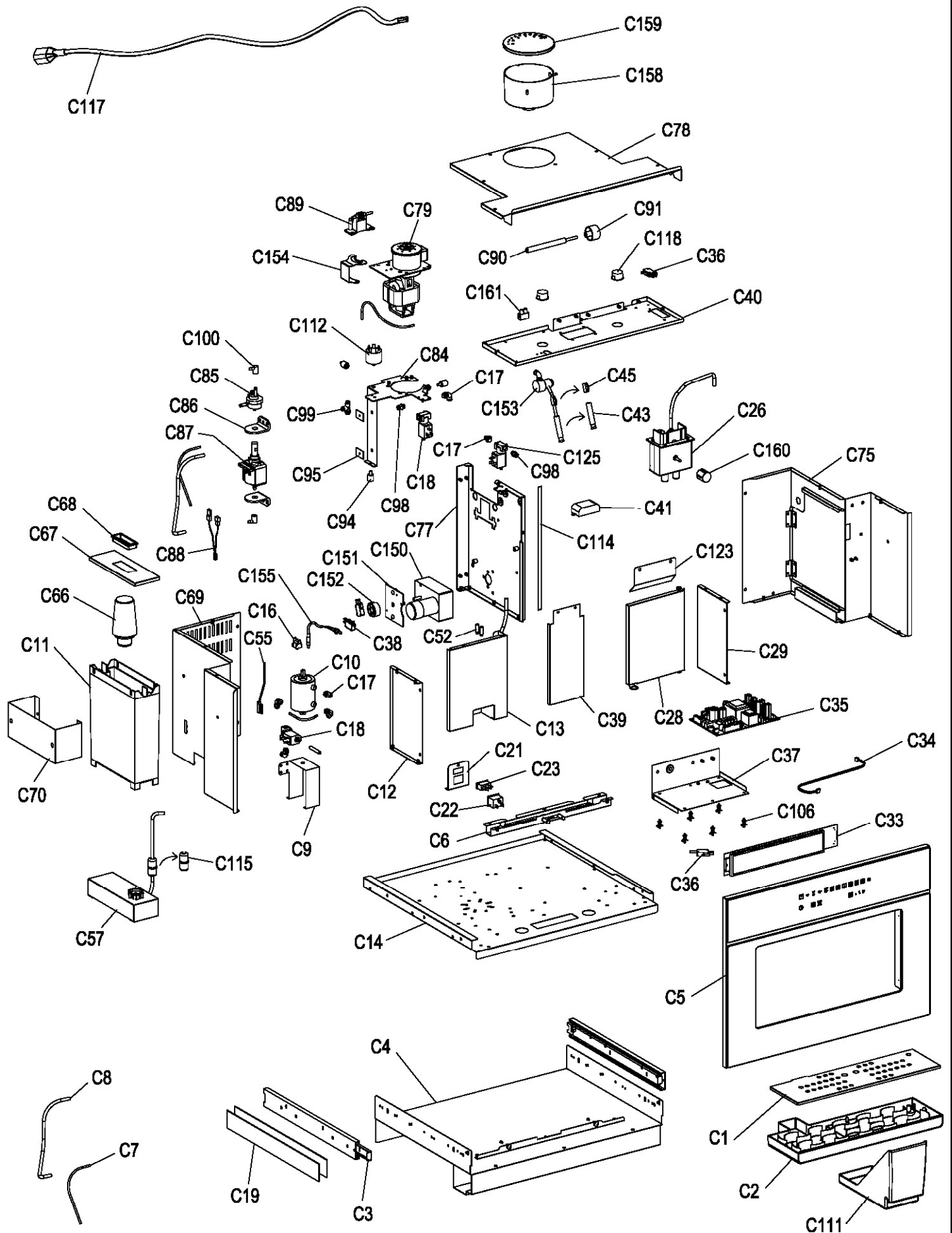

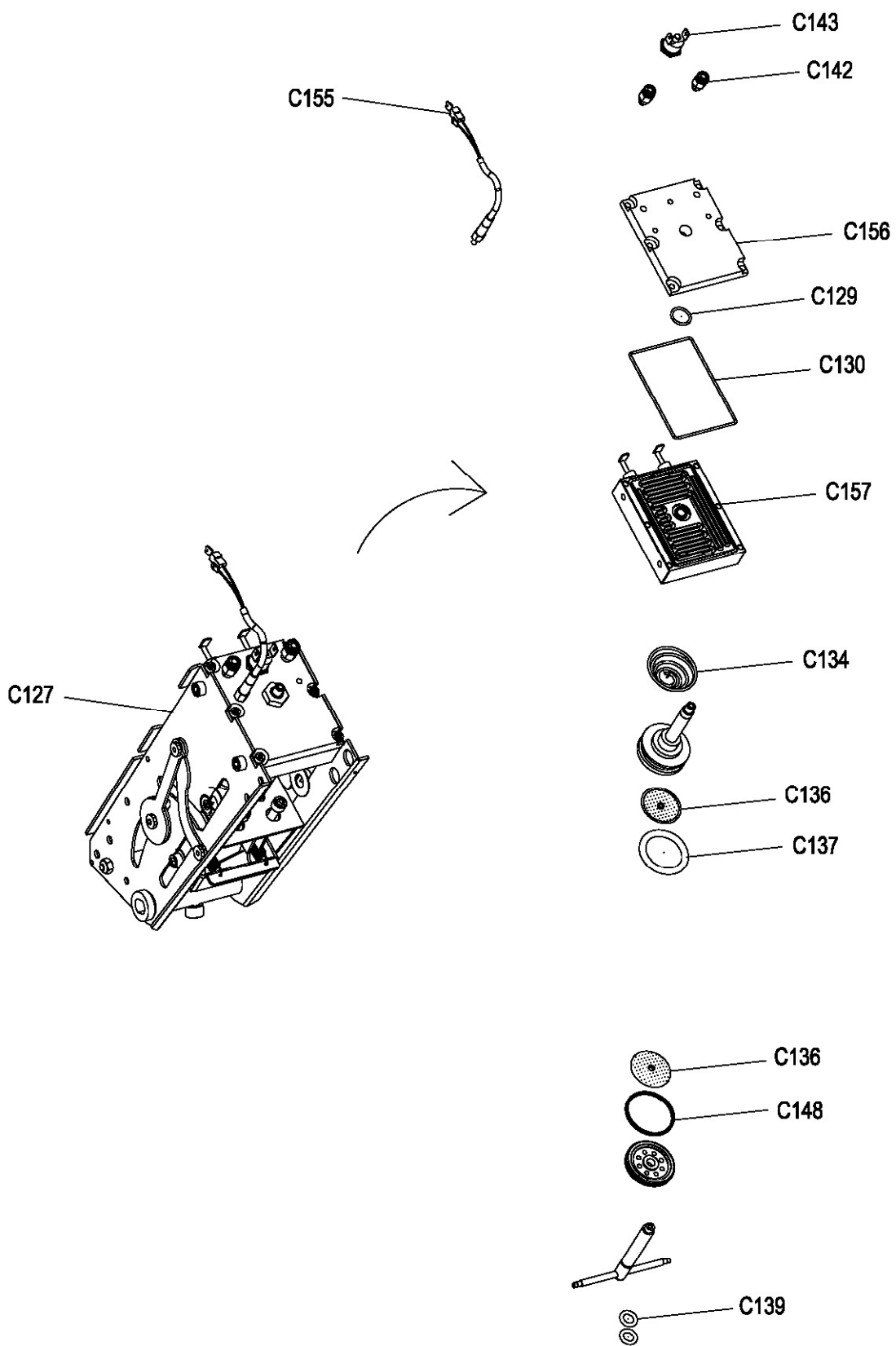



CM471SS - Caple Coffee Machine

Item	Part Code	Description
C1	141900160	CUP GRID
C2	447200480	WASTE RESERVOIR
C3	146000000	COFFEE MACHINES FOR INTEGRATEDCOFFE MACHINE
C4	447200270	"U" MACHINE ASSEMBLY
C5	447130090	PANEL ASSEMBLY LARGO CAPLE
C6	147200680	CLOSURE SYSTEM KIT
C7	143800490	TEFLON PIPE Ø4
C8	143800440	SILICON PIPE 7X4
C9	147200290	STEAM EXCHANGER SUPPORT
C10	445700010	STEAM EXCHANGER
C11	447200470	WATER TANK
C12	147200110	LEFT GUARD ST/STEEL
C13	147200450	LEFT FRONTAL GUARD WITH SPLASHER
C14	147200240	MACHINE BASE
C16	145400050	SAFETY THERMOSTAT
C17	144100000	RAPID CONNECTOR
C18	145400000	3 WAYS VALVE NC 1/8" Ø1,2 230V50Hz 0-20bar
C19	440900000	KIT LATERAL PLASTIC PLATE
C21	147200360	PLUG SWITCH SUPPORT
C22	145300000	POWER SUPPLY PLUG
C23	145400080	MAIN SWITCH
C26	447200000	COFFEE DISPENSER
C28	147200150	FRONTAL DOOR ST/STEEL
C29	147200120	RIGHT PANEL ST/STEEL
C33	145400120	TOUCH SENSOR
C34	147500010	POWER BOARD CONNECTING CABLE
C35	145400130	POWER BOARD
C36	145400040	MICRO SWITCH
C36	145400030	MICRO SWITCH LATERAL DOOR
C37	147200260	POWER BOARD SUPPORT
C38	05EI256001	DOOR LATCH MICROSWITCH
C39	147200140	CONTROL PANEL
C40	147200220	DISPENSER HOLDER
C41	145400100	CONTROL GEARS FOR LED
C43	142800150	STEAM PIPE
C45	143800200	HANDLE STEAM PIPE
C52	142800170	AREATOR FOR WATER
C55	145400070	MAGNETIC SENSOR
C57	447200590	TANK HOLDER ASSEMBLY
C66	142100010	WATER FILTER
C67	141900390	ST/STEEL COVER FOR WATER TANK
C68	143800260	BLACK HANDLE
C69	147200200	LEFT CARTER
C70	141900530	TANK CLAMP



CM471SS - Cagle Coffee Machine

Item	Part Code	Description
C75	447200620	RIGHT CARTER WITH DOOR
C77	147200320	GROUP HOLDER
C78	141900520	MACHINE COVER
C79	447200010	KIT GRINDER MOTOR
C84	147200280	PLATE FOR GRINDER
C85	145400010	FLOW MEASUREMENT
C86	143800150	ANTI-VIBRATION STANDARD
C87	145900010	PUMP EP4 240V 50Hz 48W
C88	12541440	THERMOPROTECTOR FOR PUMP
C89	146000020	HOLDER SNAIL
C90	142800080	EXTENTION FOR GRINDER
C91	147400000	BLACK KNOB FOR GRINDER
C94	143800140	RUBBER ANTI-VIBRATION
C95	141900230	LOCKING PLATE FOR PUMP
C98	144100020	RAPID CONNECTOR 4X1/8" GAS
C99	144100010	T RAPID CONNECTOR 4X1/8" GAS
C100	143800160	PLASTIC PIPE
C106	143800300	PLASTIC HOLDER FOR MAINBOARD
C111	143800290	BASIN COFFEE GROUNDS
C112	145400180	LRC FILTER
C114	143800590	MAGNET
C115	142100030	WATER FILTER
C117	145000010	POWER CABLE WITHOUT PLUGIN
C118	145400090	LED LAMP
C123	141900130	COFFEE GROUP PROTECTION
C125	145400110	3 WAYS VALVE NC 1/8" Ø2 230V 50Hz 0-5bar
C127	447200600	AUTOMATIC COFFEE GROUP
C129	16921734	O.R. VITON 14X1,78
C130	143800190	O.R. VITON 85,34X1,78
C134	142300020	NONIC SPRING (TEFLON) FOR PIST
C136	142100020	COFFEE FILTER DIAMETER 34 MM
C137	16925034	OR 31,12X5,33 (IN SILICONE ROSSO)
C139	16924534	OR 9X3 R.70
C142	144100030	RAPID CONNECTOR M5 FOR PIPE Ø4
C143	145400060	SAFETY THERMOSTAT 165°C
C148	16926144	QRING VITON 37.82X1.78
C150	145900030	GEARMOTOR GROUP BITRON 24V
C151	143800170	MICROSWITCH SUPPORT
C152	145400170	CAM FOR GEARMOTOR
C153	447200040	STEAM DISPENSER
C154	141900280	SUPPORT WITH LOCKING FUNCTION
C155	147500020	NTC PROBE
C156	142800090	COVER EXCHANGER
C157	147200060	HEAT EXCHANGER KIT 470W 230V
C158	447200490	KIT CAMPANA
C159	143800130	COVER FOR CAMPANA
C160	143000010	KNOB FOR COFFEE DISPENSER
C161	115300090	2P 16A PA44 FV TERMINAL BLOCK



CM471SS

Caple built in coffee machine



Service Manual

CONTENTS

1. SERVICING REQUIREMENTS

1.1 HEALTH & SAFETY

- 1.1.1 Electrical Safety
- 1.1.2 Good Working Practices
- 1.1.3 Insulation Test
- 1.1.4 Sheet Metal Edges

1.2 SPECIAL TOOLS & MATERIALS

- 1.3.1 Tools
- 1.3.2 Necessary Measuring Instrument

2. TECHNICAL OVERVIEW

2.1 COFFEE MAKER SPECIFICATIONS

- 2.1.1 Coffee Maker Weight
- 2.1.2 Power Rating

2.2 SERIAL PLATE

- 2.2.1 Location
- 2.2.2 Model and Serial Number

2.3 COMPONENT SPECIFICATIONS

- 2.3.1 Heating Elements
- 2.3.2 Motors
- 2.3.3 Electric Components

2.4 SYSTEM DESCRIPTION

2.5 TEST PROCEDURE

2.6 FAULT ALARMS

2.7 OVEN SAFETY FUTURES

- 2.7.1 Safety Fuse
- 2.7.2 Safety Thermostats

4. TROUBLE SHOOTING GUIDE

4.1 FAULT ALLARM

4.2 COFFEE MAKER DOESN'T SWITCH ON

4.3 THE MACHINE DOES NOT DISPENSE COFFEE

- 4.4 THE MACHINE DOES NOT DISPENSE STEAM OR HOT WATER
- 4.5 THE ON/OFF LIGHT BLINKS CONTINUOUSLY FOR MORE THAN 15 MIN
- 4.6 WATER INTO GROUNDS DRAWER

7. COMPONENT REPLACEMENT AND ADJUSTMENT PROCEDURE

- 7.1 COFFEE MAKER REMOVAL
- 7.2 UPPER COVER REMOVAL
- 7.3 RIGHT COVER REMOVAL
- 7.4 LEFT COVER REMOVAL
- 7.5 HEAT EXCHANGER SUBSTITUTION
- 7.6 PUMP SUBSTITUTION
- 7.7 AUTHOMATIC APPARATUS SUBSTITUTION
- 7.8 AUTHOMATIC APPARATUS GEAR MOTOR SUBSTITUTION
- 7.9 GEAR MOTOR CAMME SETTING
- 7.10 COFFEE GRINDER SUBSTITUTION
- 7.11 FRONTAL AESTHETICS SUBSTITUTION
- 7.12 WATER/STEAM DISPENSING NOZZE SUBSTITUTION
- 7.13 COFFEE SOLENOID VALVES SUBSTITUTION
- 7.14 STEAM SOLENOID VALVE SUBSTITUTION
- 7.15 WATER COUNTER SUBSTITUTION
- 7.16 INTERFERENCE FILTER SUBSTITUTION
- 7.17 LED TRANSFORMER SUBSTITUTION
- 7.18 LED LIGHT SUBSTITUTION
- 7.19 SAFETY THERMOSTATS RESET OR SUBSTITUTION
- 7.20 MAIN FUSE CHECK OR SUBSTITUTION
- 7.21 WATER LEVEL SENSOR SUBSTITUTION
- 7.22 DISPLAY BOARD SUBSTITUTION
- 7.23 POWER BOARD AND FUSES SUBSTITUTION
- 7.24 NTC PROBE SUBSTITUTION
- 7.25 MICRO SWITCHES SUBSTITUTION
- 7.26 MAIN SWITCH & PLUG SOCKET SUBSTITUTION
- 7.27 UNLOCKING LEVER SYSTEM SUBSTITUTION
- 7.28 COFFEE HEATER SUBSTITUTION
- 7.29 BUFFER'S GASKET AND FILTER SUBSTITUTION
- 7.30 COFFEE CUP'S GASKET AND FILTER SUBSTITUTION
- 7.31 GASKET OF COFFEE CUP SPINDLE SUBSTITUTION

Note: When servicing the oven, health and safety issues must be considered at all times. Specific safety issues are listed below with their appropriate icon. These are illustrated throughout the service information to remind service people of the health and safety issues

1.1.1 **Electrical Safety**



WARNING! TO AVOID ELECTRIC SHOCK!

Do not attempt to service this oven without suitable training and qualifications.

Though it is free from danger in ordinary use, extreme care should be taken during repair.

BEFORE TOUCHING any parts of the oven, always remove the power plug from the outlet.

Ensure the main power has been disconnected before servicing any part of the oven. If the power is required to be on for electrical fault finding, then **extreme** care should be taken not to make contact with electrical components other than with testing probes.

Ensure the oven is turned off when removing any electrical component or connection.

1.1.2 **Good Working Practices**



Ensure the work areas are kept tidy and free of hazards while servicing the oven. On completion of the servicing, ensure the oven and work areas are left clean and tidy.

1.1.3 **Insulation Test**



Megger test to check insulation.

1.1.4 **Sheet Metal Edges**



When working around cut sheet metal edges use appropriate gloves or protection to eliminate the chance of receiving a laceration.

1.3.1 Tools

- .5V Power Screw / Nut Driver Recommended
- 3" socket extension bar
- 7mm socket
- 10 mm socket
- 12mm socket
- Flexible shaft socket extension
- Short Phillips Screw driver set
- Short torx Screw driver set
- Diagonal pliers
- Long nose pliers
- Flat blade screwdriver
- Vinyl insulation tape
- Polishing cloth
- Allen keys set
- Metric Combination Wrench Set

1.3.2 Necessary Measuring Instruments

- TESTER (VOLTS-DC, AC, Ohmmeter)

2.1.1 Net Weight

lbs /Kg =57/26

2.1.2 Power rating

TECHNICAL DATA

COFFE MAKER	Electrical Ratings and Maximum Connected Load	
	@ 220-240 Volts 50Hz	
	Amperes	Watts
CM461 – CM471	8.6	2000

2.2.1 Location

The product serial number plate is located on the bottom profile trim.

2.2.2 Model & Serial Number

The numbers printed on the plate contains the following information:



Components Specifications

2.3.1	Heating Elements	Volts	Freq.	Watts	Note
	Coffee Heater	230	--	500	
	Steam Water Heater	230	--	1200	

2.3.2	Motors	Volts	Freq.	Watts	Note
	Grinder Motor	230	50/60	100	
	Apparatus Motor	24 DC		12	4.2 RPM
	Pump	230	50	48	

2.3.3	Electric Components	Volts	A	Watts	Note
	Led Lamp	12	--	2	
	Transformer	Prim 240 Sec 12V	350mA	4	
	Safety Thermostats - Steam Water Heater	230	16	--	200°C
	Safety Thermostats - Coffee Heater	230	16	--	165°C
	NTC Probe Temperature - Steam Water Heater				100 Kohm 200°C
	NTC Probe Temperature - Coffee Heater				100 Kohm 200°C
	Flow meter	12			
	Service Door Micro Switch		16		N°2
	Door Micro Switch		16		N°1
	Apparatus Motor Micro Switch		16		N°2
	Water valve-Coffee Out	230	--	--	1/8" 0-5 bar 50Hz
	Water valve-Coffee Inlet	230	--	--	1/8" 0-20 bar 50Hz
	Water valve-Water & Steam	230	--	--	1/8" 0-20 bar 50Hz
	Water level sensor				

HYDRAULIC DIAGRAM

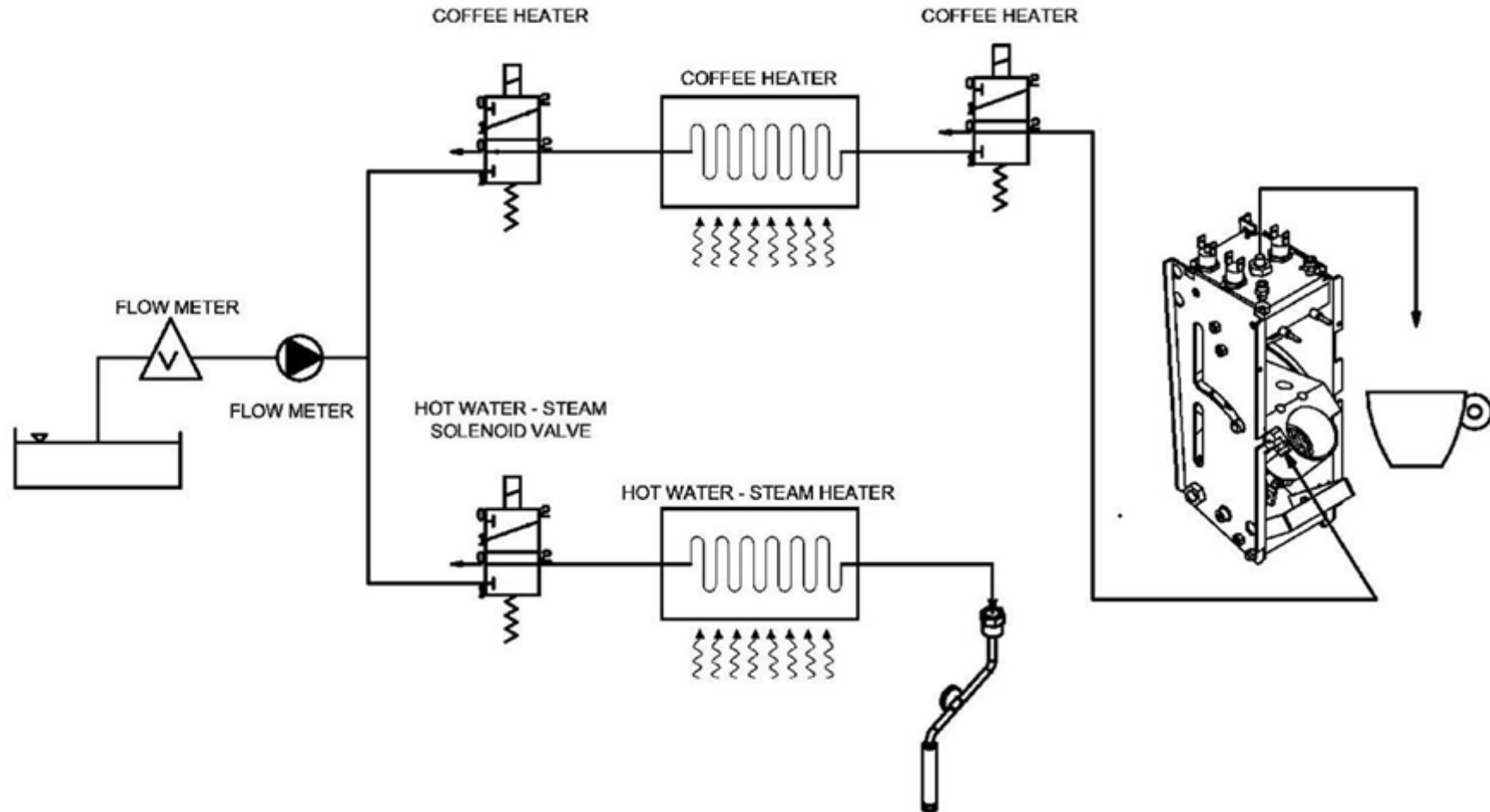

Both circuits, hot water/steam and coffee, use the same pump. Hence functions must be performed individually. Below is a short description of the dynamics and operating sequences concerning the three main functions:

-Coffee:

Once the required dose has been selected and the cycle has been started, powder preparation and automatic unit positioning is followed by pump operation and the

opening of the two solenoid valves. At this point, the water flows through the flow meter which determines the dose, through the pump, the first solenoid valve, the heat exchangers for the coffee and the second solenoid valve and then enters the plastic body of the automatic unit. Here, after passing through the coffee pod, the coffee is collected by the brass part mounted on the same heat exchanger from which it protrudes thanks to a silicone pipe and reaches the dispenser. Once the cycle has terminated, the solenoid valves de-energize and drain the fluid still in the circuit into the drip tray.

-Hot water:

Once the function has been selected, keep the start key pressed for the required dispensing time.

Upon starting the appliance, the pump and the hot water/steam solenoid valve are started, the water pushed by the pump flows through the first solenoid valve and then enters the hot water/steam exchanger.

Once it has crossed the exchanger, it is conveyed to the hot water/steam outlet pipe junction.

Once the start key is released, the solenoid valve de-energizes and switches over so the fluid still in the circuit is drained into the drip tray.

-Steam:

Once the function has been selected, keep the start key pressed for the required dispensing time.

When the appliance is switched on, the pump and the hot water/steam solenoid valve are started, the solenoid valve in normal operation and the pump by means of short but frequent pulses. The water pushed by the pump flows through the first solenoid valve and then enters the hot water/steam exchanger.

Once it has crossed the exchanger, it is conveyed to the hot water/steam outlet pipe junction.

Once the start key is released, the solenoid valve de-energizes and switches over so the fluid still in the circuit is drained into the drip tray.

Test procedure Coffee Maker



Control panel
Description of the buttons and indicator lights on the control panel.

	ON/OFF button
	START/STOP button
	COFFEE button
	STRETCHED COFFEE button
	WATER button
	NO WATER alarm
	GROUNDS PRESENT alarm
	GENERIC ALARM
	WASH button

	LIGHT button
	DOUBLE COFFEE button
	DOUBLE STRETCHED COFFEE button
	STEAM button
	REPLACE FILTER alarm
	COFFEE probe broken alarm
	COFFEE regulation
	LIGHT COFFEE
	MEDIUM COFFEE
	STRONG COFFEE

FUNCTIONAL TESTING

1. Turn ON the appliance.
2. Wait for the exchanges reach the set temperature. Check the power 2000w.
3. Dispense hot water to check the seal of hydraulic system (except part coffee).
4. Make some washing functions to verify the movement of the coffee unit and its hydraulic seal.
5. Turn off the machine.
6. Perform the test: check the proper functioning of the buzzer. hold the light key until a continuous sound is heard .



Turn on the machine and check the sound of all keys. Switch off and hold the light key until a short sound is heard.

7. Make the reset (resetting the default values) hold the below key until all LED are lighted.



5 sec finché led non lampeggiano tutti

8. Dispense a coffee to verify the grinding (not consider the first dispense).

9. only if a service action is performed on one of electronic board.

Check that the electronic board maintains the programming proceed as follows:

- press the coffee key for 5 seconds until it flashes



Fig.p1

- press start / stop key to start the dispense, both led flashing during dispensing.



Fig. p2



Fig. p3

- Press again the key start / stop once the desired quantity is reached.

Test programming and verification of grinding time.

- Enter in test mode from OFF status, press for 5 seconds start/stop key.
- The led of upper row are lit (red light) from left to right they indicate the grind time for strong coffee (the only that is programmed, the others two arising as result):
- **Medium coffee** = strong coffee - 1.5 sec. **Long coffee**=strong coffee = - 3 sec.
- Led flashing shows 0.3 seconds.
- The programming sequence is the following:
- 4.5, 4.8, 5.1(12 led)

The select grind key increase the time
 The start / stop key decrease the time

- To save press on / off key

10. Set default values (see paragraph 7).
11. Set grinding time as done before to perform the default procedure.??
12. Dispense coffee to verify the default values: 40 ml short coffee and 70 ml long coffee.



13. Perform a final wash.

14. Check steam dispense (approx 30 "). 

15. Reset the count coffee maintaining the frontal door opened (approx 15 "). 

16. Check the functionality of level sensor of water checking the correspondent signal.

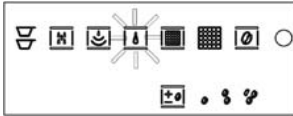
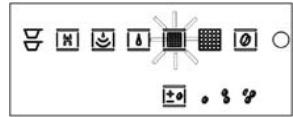
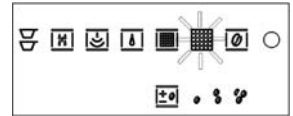
17. Turn off the machine.

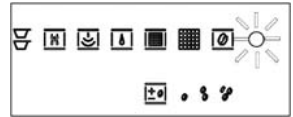
Faults		
No water	The machine has a sensor that checks for water in the tank. If there is no water, the machine turns on the indicator light and will not work until the tank is filled.	
Replace filter	After the machine has dispensed 80 litres of water, the LED for the filter symbol begins to flash (pre-alarm). If the quantity of dispensed water reaches 100 litres, the LED will turn steady-on (alarm). The replacement of the filter is recommended within 3 months from when the LED remains steady-on. To switch-off the alarm (or the pre-alarm), put the appliance in stand-by condition, hold the START/STOP button for 5 seconds; the alarm led will switch-off and the counter of dispensed water will reset.	
Mandatory washing and presence of coffee grounds	After dispensing 10 cups of coffee, the wash light turns on steady red, while the grounds drawer LED flashes with a red light. This condition persists even when the machine is turned off and on. To reuse the machine, you must wash the coffee unit by pressing the START/STOP button with a container under the coffee dispensing nozzles to hold the water. After washing, open the grounds drawer, empty it and close it. During washing, the START/STOP icon flashes red and then turns off after washing.	
Coffee probe broken	The machine has a function that warns you when the coffee unit probe is broken. When the coffee probe is not working correctly, the relative LED flashes. Try to turn the machine off and on.	
Generic alarm	The generic alarm indicator lights up for a variety of possible reasons: <ul style="list-style-type: none"> • The automatic coffee dispensing unit is blocked; • The movement of the automatic coffee dispensing unit did not occur correctly; • The door for removing the coffee grounds is open; • The volumetric counter did not detect the passage of water; • The temperature probe is not working correctly. If the generic alarm light turns on: <ul style="list-style-type: none"> • Check that the grounds emptying door is closed . • Check that there is water in the tank. 	

Coffee Maker Safety Features

2.7.1 Safety Fuses

This appliance is built with a main FUSE on power supply plus a couple fuses on Power Board for auto protection.





2.7.2 Safety Thermostats

This appliance is built with a bi-metal mechanical thermostats. The two safety thermostats on the coffee exchanger and on the steam/hot water exchanger can be manually reset.

The function of the safety thermostat is to protect the of the appliance from overheating in the event of a malfunction of the temperature regulation. In the event that the temperature is rising over the limits, the thermostat will switch mechanically from off position to on position and all of the heating elements will be cut off from the power. All of the electronics will be still powered.

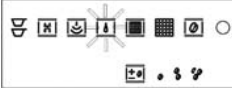
The manual reset have to be performed when the problem was solved and the temperature is in the right functioning parameters.

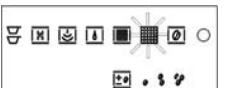
BEFORE TOUCHING any parts of the oven, always remove the power plug from the outlet.

Alarm	Description	Possible Cause	Corrective Action	section
	The control see empty water tank	Level water sensor broken.	Check the connectors and the harness Replace the sensor	7.21
	Exhaust tank filter	Norma maintenance operation	(see paragraph 2.6)	--
	Mandatory washing Blinking light	Norma maintenance operation	(see paragraph 2.6)	--
	presence of coffee grounds. Steady light	Norma maintenance operation	(see paragraph 2.6)	--
	Coffee probe error.	Appliance blocked	Switch ON/OFF the apparatus	--
		Coffee probe broken	Replace the coffee probe	7.24
	Generic Alarm. The generic alarm indicator lights up for a variety of possible reasons. Blinking light	The door for removing the coffee grounds is open;	Check that the grounds emptying door is closed	--
		The movement of the automatic coffee dispensing unit did not occur correctly; or The automatic coffee dispensing unit is blocked;	As soon as the apparatus is switched on check the power supply at 24DC on the gear motor has. If there is power replace the gear motor.	7.8
			If there is no power. Check the fuse on the power board.	7.23
		If the fuse is OK. Check the AUTHOMATIC APPARATUS EXCHANGE / SETTING	7.9	
		The volumetric counter did not detect the passage of water;	Check the functionality of volumetric counter. If broken replace it.	7.15
• The temperature probe is not working correctly.	Check the functionality of temperature probe. If broken replace it.	7.24		



Coffee maker doesn't switch ON

Anomaly	Possible Cause	Corrective Action	section	
The appliance does not switch ON No power supply	Main breaker or main fuses	Replace the fuses	--	
	Short circuit	Find the short circuit and remove it	--	
The appliance does not switch ON Power supply ok.	Main switch in the OFF position or damaged	Check the switch in case it is damaged replace with the new one.	7.26	
	Main fuse of machine broken	Check the fuse in case it is interrupted replace with the new one.	7.20	
	Fuses of power board interrupted.	Check the fuses in case they are interrupted replace with the new one.	7.23	
	Side door switches	Check the switches in case one of these are damaged replace with the new one.	7.25	
	Power boards	Check both boards in case one of these are damaged replace with the new one.	7.22 7.23	
	The power supply to the display board	Verify if the voltage is correct on the Control board. Check the connections and eventually replace the main power board.		7.23
		If the voltage is correct (DC 20V or 5V) the control board is OK. Replace display board.		7.22

The Machine Does Not Dispense Coffee

Anomaly	Possible Cause	Corrective Action	section
The appliance switch ON It does not dispense coffee	The exchanger does not reach the required temperature	Check the safety thermostat in case it is tripped is necessary to fix the cause and reset it.	<u>7.19</u>
		Check the heating element of coffee automatic apparatus exchanger , in case it is damaged replace it.	<u>7.7</u>
		The NTC sensor ohmmeter, if it is interrupted replace the NTC.	<u>7.24</u>
	The coffee automatic apparatus cannot move in the correct position.	Check the gear motor power supply in case the power supply is ok, replace it.	<u>7.10</u>
		Check the gear motor power supply, in case the power supply is not present, check the FUSE, connections and power board relay. If damaged replace it.	<u>7.23</u>
		Check the gear motor micro switch, see setting micro switch paragraph.	<u>7.9</u>
	Water pump does not work	Check the pump power supply, in case the power supply is ok, replace the pump.	<u>7.6</u>
		Check the pump power supply, in case the power supply is not present, check the FUSE, connections and power board relay.	<u>7.23</u>
		Check if the silicon tubes and filter are clogged.	--
	The valve doesn't work	Check the solenoid valve power supply, in case the power supply is ok replace it.	<u>7.13</u>
		Check the solenoid valve power supply, in case the power supply is not present, check connections and power board relay. If damaged replace it.	<u>7.23</u>
	The filters are clogged	Check the buffer filter	<u>7.29</u>
		Check the cup filter	<u>7.30</u>

The Machine Does Not Dispense Steam or Hot Water

<i>Anomaly</i>	<i>Possible Cause</i>	<i>Corrective Action</i>	<i>section</i>
The appliance switch ON It does not make steam	The exchanger does not reach the required temperature	Check the safety thermostat in case it is tripped is necessary to fix the cause and reset it.	7.19
		Check the heating element of steam exchanger , in case it is damaged replace it.	7.5
		The NTC sensor ohmmeter, if it is interrupted replace the NTC.	7.24
	Water pump does not work	Check the pump power supply, in case the power supply is ok, replace the pump.	7.6
		Check the pump power supply, in case the power supply is not present, check the FUSE, connections and power board relay. If damaged replace it.	7.23
		Check if the silicon tubes and filter are clogged.	--
	The valve doesn't work	Check the solenoid valve power supply, in case the power supply is ok replace it.	7.14
		Check the solenoid valve power supply, in case the power supply is not present, check connections and power board relay. If damaged replace it.	7.23

The On/Off light blinks continuously for more than 15 Min

Anomaly	Possible Cause	Corrective Action	section
<i>The On/Off light blinks continuously for more than 15 Min</i>	The coffee automatic apparatus does not reach the required temperature	Check the safety thermostat in case it is tripped is necessary to fix the cause and reset it.	7.19
		Check the heating power supply, in case the power supply is not present, check the FUSE, connections and power board relay. If damaged replace it.	7.23
		Check the power supply heating element of coffee apparatus, if it is ok the heating element is damaged, replace the coffee apparatus.	7.7
		The NTC sensor ohmmeter, if it is interrupted replace the NTC.	7.24

Water into grounds drawer

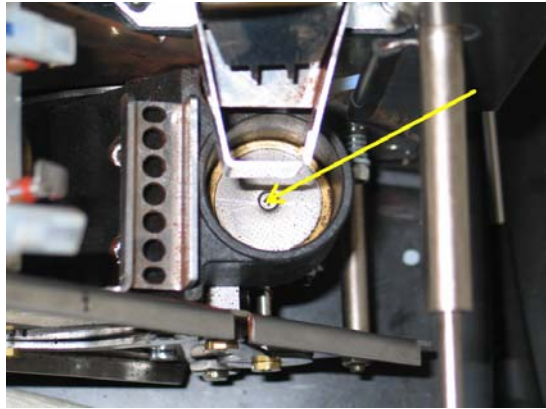
<i>Anomaly</i>	<i>Possible Cause</i>	<i>Corrective Action</i>	<i>section</i>
<p>Presence of water into grounds drawer.</p>	<p>The screw into the grinded coffee cup is loosened .</p> 	<p>Tighten the screw</p>	<p>--</p>
	<p>The gaskets of coffee dispenser have lost their seal.</p>	<p>Check the gaskets in case one of them are damaged replace it.</p>	<p><u>7.29</u> <u>7.30</u> <u>7.31</u></p>



1. Remove the drip basin from its seat.
2. Press the unlocking lever under the drip basin and pull the machine towards you as shown in the fig.1.
3. Pull the coffeemaker out of the furniture by sliding it on its guides.
4. Disconnect the power supply cord by the back main switch.
5. Unlock the slide arms by the lateral plastic hooks fig.2.
6. Than pull out the machine.

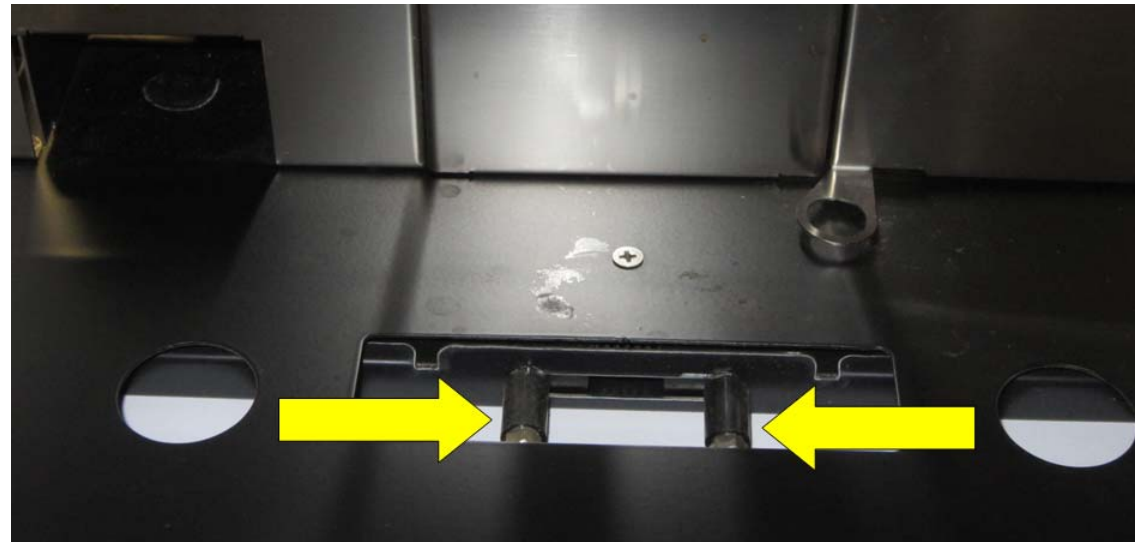

fig:1



fig:2



1. Disconnect the power supply cord and remove the appliance from the cabinet ([see par. 7.1](#)).
2. Loosen the screws on the upper part of the appliance **Fig. 1**
3. Raise and remove the lid as shown in the photo. **Fig. 2**

**Fig. 1****Fig. 2**



1. Disconnect the power supply cord and remove the appliance from the cabinet ([see par. 7.1](#)).
2. This compartment can be accessed in two ways: by means of the service door for checking the apparatus or by removing the right section of the bodywork for bigger jobs.

-SERVICE DOOR Fig. 1:

Only technical personnel must access the appliance through the service door.

Remove the screw and open the door to make necessary inspections.

-REMOVAL OF RH BODYWORK:

1. Remove the two screws on the rear. [Fig. 2](#)
2. Remove the four screws on the side. [Fig. 3](#)
3. Remove the five screws on the lower section. [Fig. 4](#)
4. Remove the grinding regulation knob as shown. Now the entire RH section can be removed and access obtained to the unit and the micro switches of the side doors and dredge unloading. [Fig. 5](#)



Fig. 2

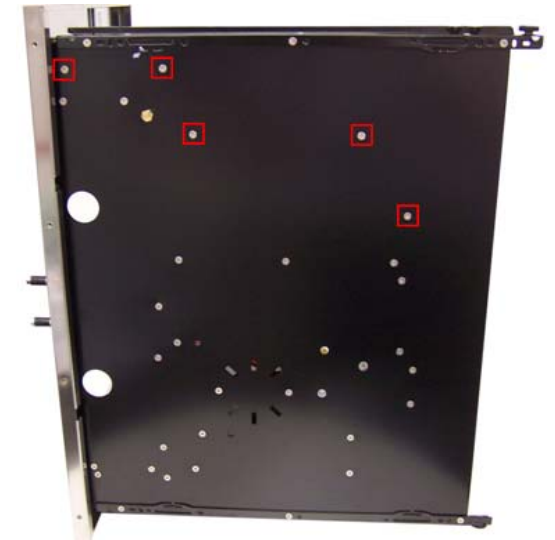

Fig. 4



Fig. 1

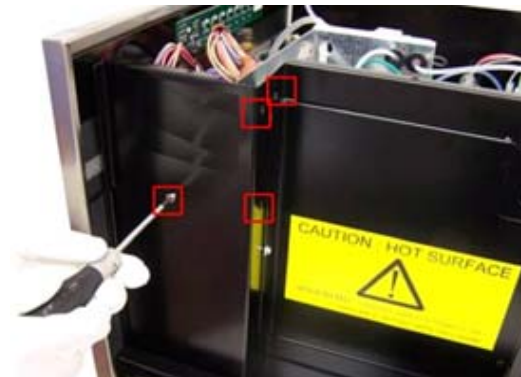

Fig. 3



Fig. 5



1. Disconnect the power supply cord and remove the appliance from the cabinet ([see par. 7.1](#)).
2. Loosen the two retention screws of the tank support band by inserting the tool through the holes shown in the illustration. **Fig. 1**
3. Once the tank support has been removed, loosen the two side screws as shown in the illustration. **Fig. 2**
4. Loosen the retention nut of the pump-grinder support indicated in the photo and remove the two back screws as shown in the illustration.. **Fig. 3**
5. Loosen the screw shown in the photo. **Fig. 4**
6. Remove the five retention screws shown in the bottom of the machine. **Fig. 5**



Fig. 1

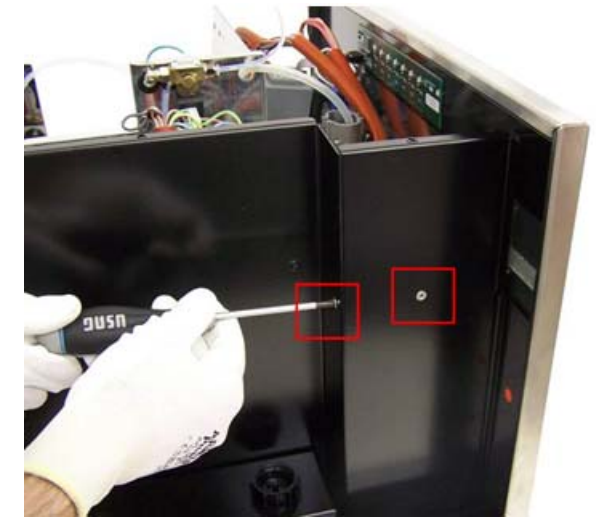

Fig. 2

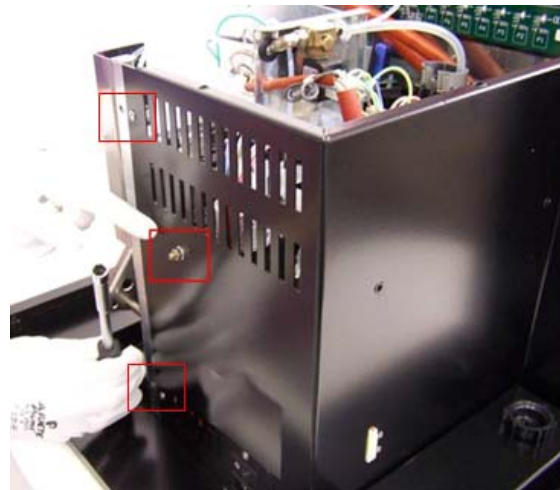

Fig. 3

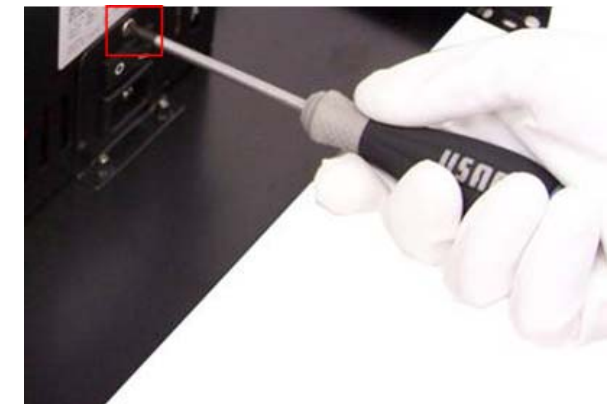

Fig. 4

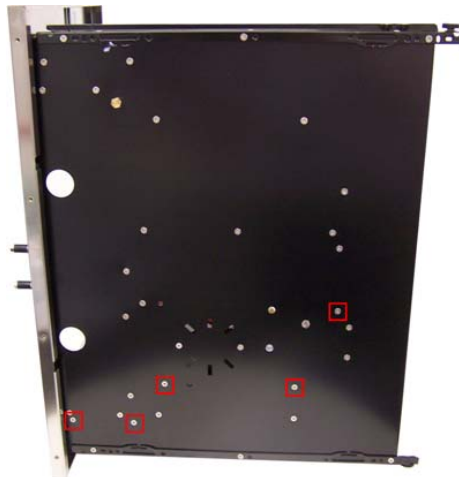
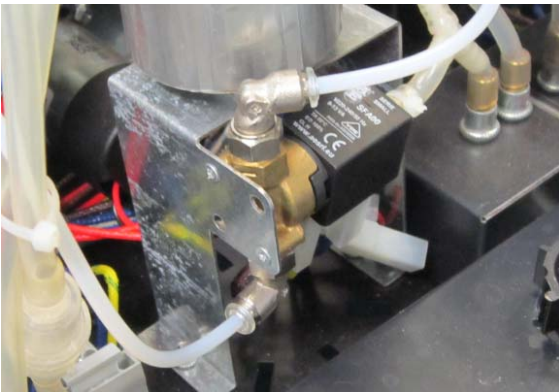

Fig. 5

Heat Exchanger substitution

1. Disconnect the power supply cord and remove the appliance from the cabinet. ([see par. 7.1](#))
2. Remove the upper cover. ([see par. 7.2](#))
3. Remove the left side cover. ([see par. 7.4](#))
4. Disconnect the terminals from the exchanger on the top.
5. Remove the probe A and thermostat B on the top of exchanger.
6. Then disconnect both PVC tubes from the pipes C.
7. Remove the solenoid valve ([fig.1](#)) to have access to the bottom nut of exchanger, unscrew the bottom nut D and remove it.
8. Replace the new one by reversing the previous steps.
9. Connect the terminals.
10. The connections must not be loose.
11. Reinstall the appliance into the cabinet.
12. Reconnect the power supply.
13. Run it and check all functions.



(fig.1)

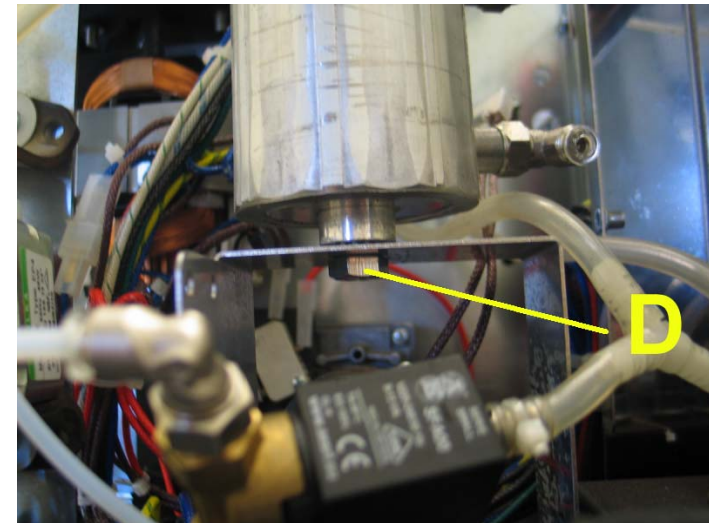



1. Disconnect the power supply cord and remove the appliance from the cabinet. ([see par. 7.1](#))
2. Remove the upper cover. ([see par. 7.2](#))
3. Remove the left side cover. ([see par. 7.4](#))
4. Disconnect the terminals from the pump.
5. Remove both screw A .
6. Disconnect the PVC tubes from the pipes B.
7. Remove the pump.
8. Replace the new one by reversing the previous steps.
9. Connect the terminals.
10. The connections must not be loose.
11. Reinstall the appliance into the cabinet.
12. Reconnect the power supply.
13. Run it and check all functions.

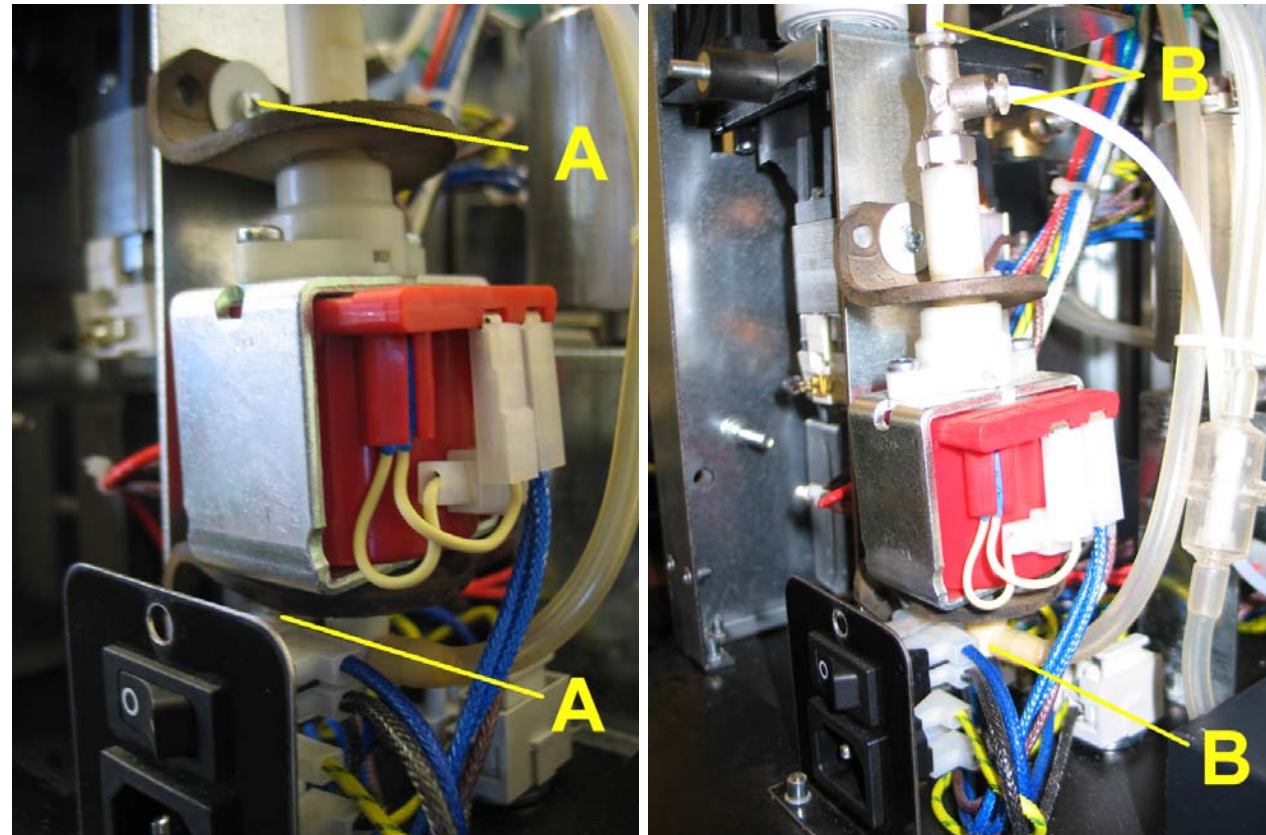

Automatic Apparatus substitution

1. Disconnect the power supply cord and remove the appliance from the cabinet. ([see par. 7.1](#))
2. Remove the upper cover. ([see par. 7.2](#))
3. Remove the right side cover. ([see par. 7.3](#))

4. If jobs have to be done on the automatic unit, disconnect the delivery and exit pipes of the exchanger, proceeding as indicated under "QUICK-COUPLING CONNECTIONS".

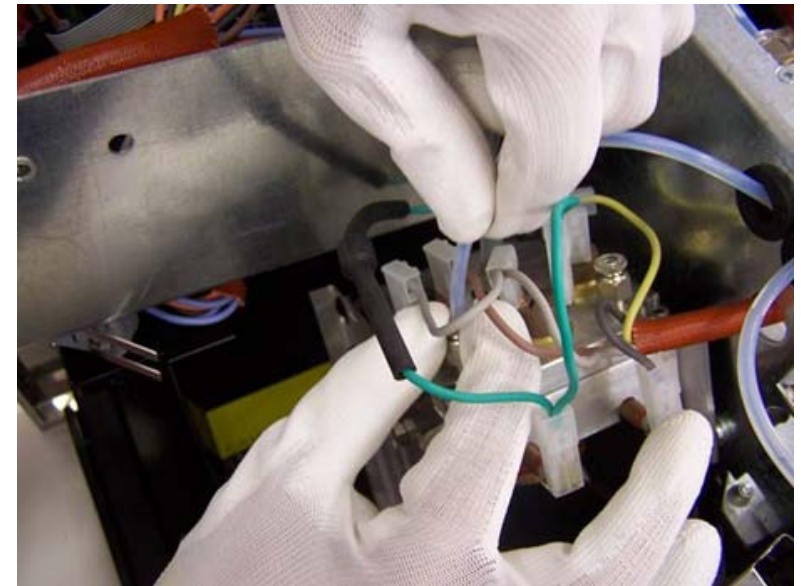
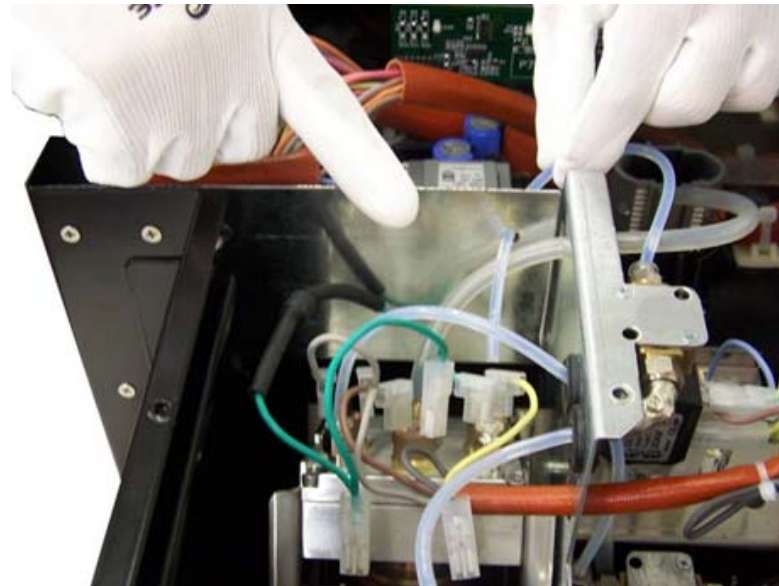

5. Disconnect the silicone pipe from the brass part located at the centre of the

exchanger cover.

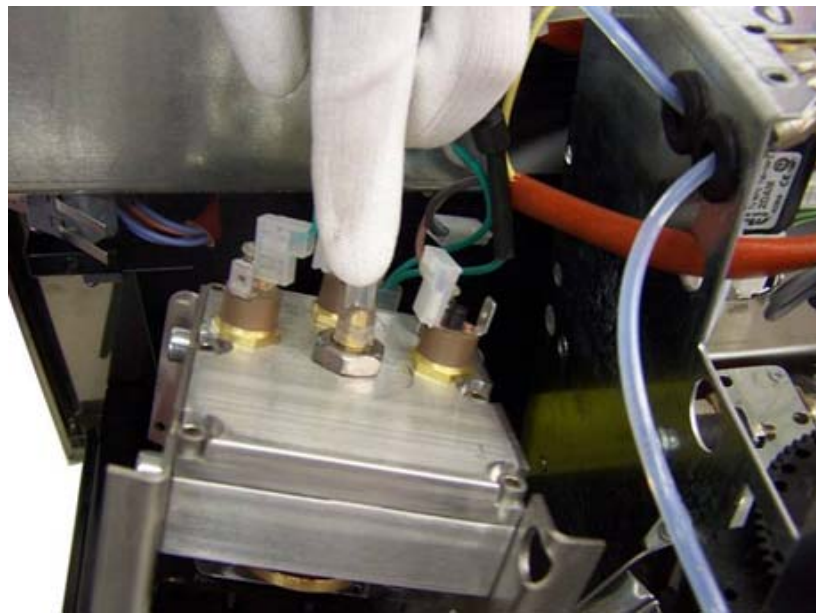

6. Loosen the upper retention screw of the unit introducing the tool through the holes shown in the illustration.

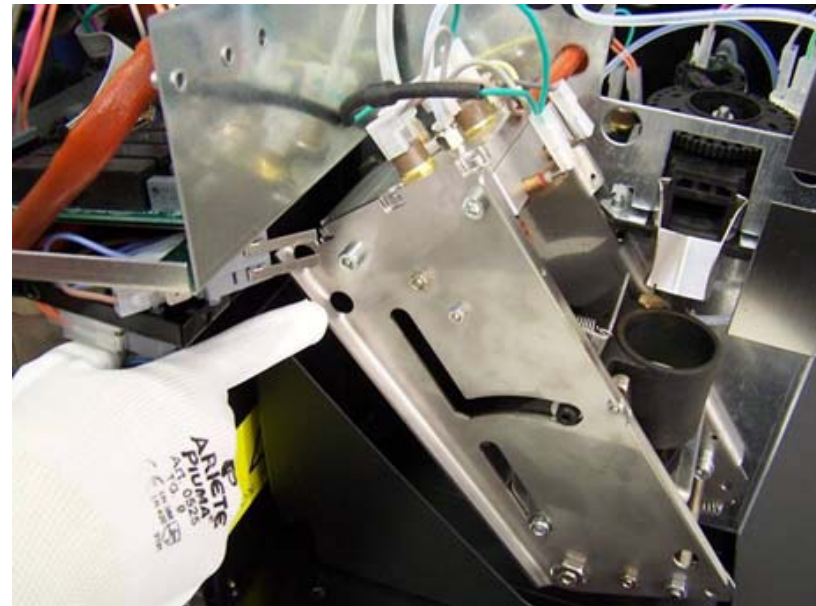

7. Loosen the lower retention screw as shown in the illustration.

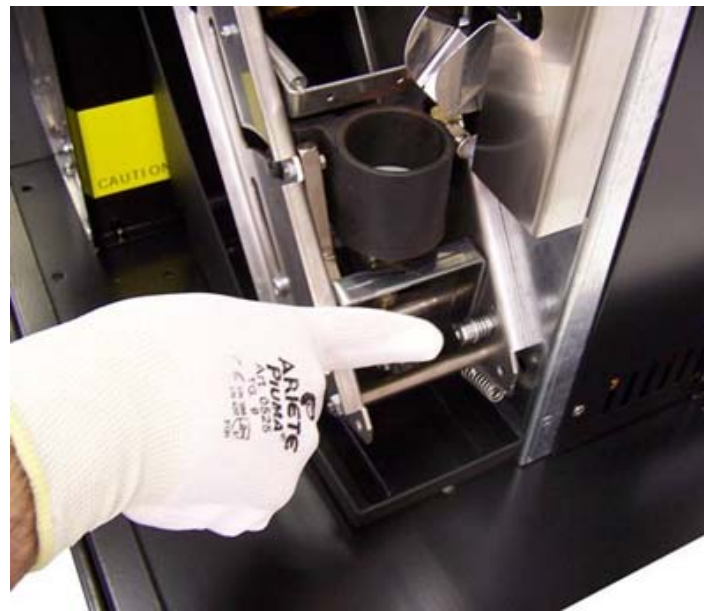

8. Now the unit can be removed by pulling it towards you

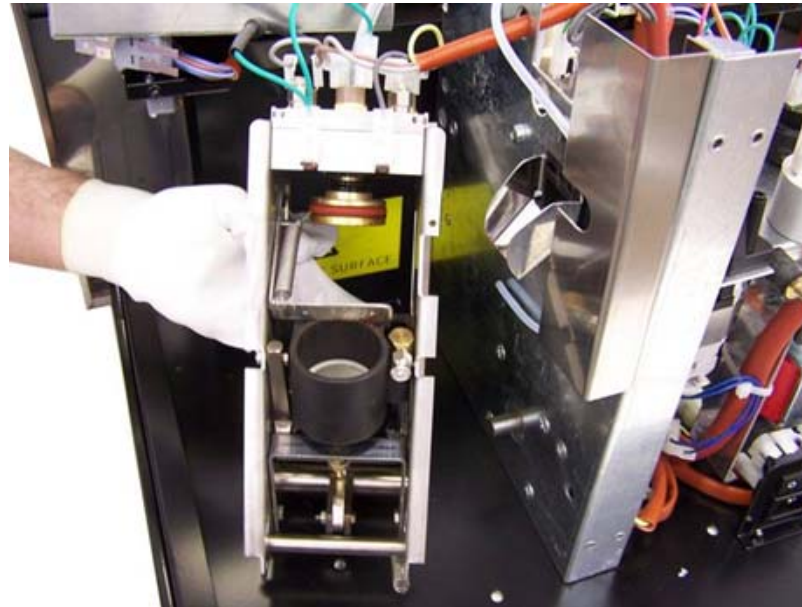

9. Replace the new one by reversing the previous steps.
10. Connect the terminals.

11. The connections must not be loose.
12. When fitting the automatic unit back on, be careful to correctly fit the pin of the same unit on the motor shaft as shown in the illustration.

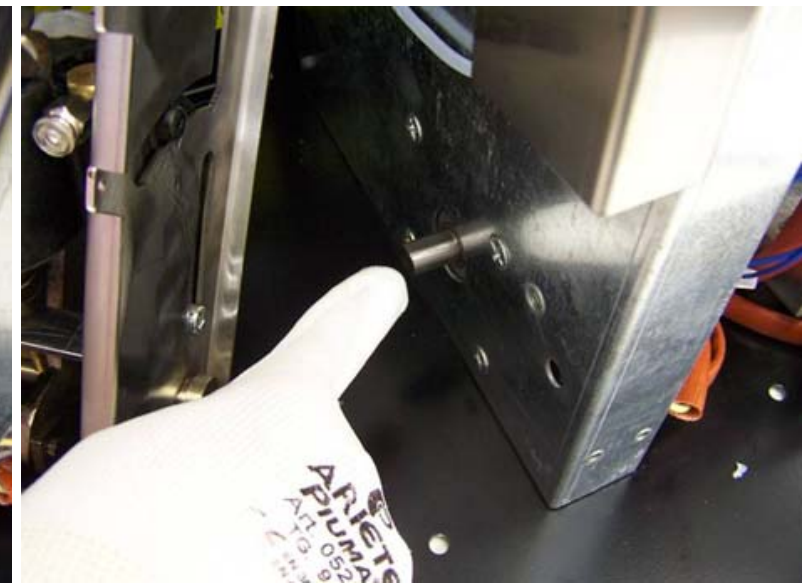
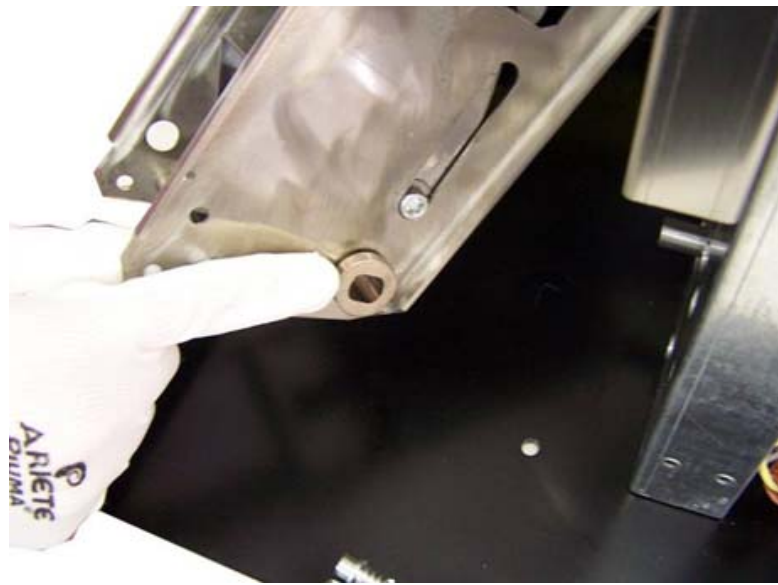

13. Reinstall the appliance into the cabinet.
14. Reconnect the power supply.
15. Run it and check all functions.

Automatic Apparatus Gear motor substitution & setting



1. Disconnect the power supply cord and remove the appliance from the cabinet. ([see par. 7.1](#))
2. Remove the upper cover. ([see par. 7.2](#))
3. Remove the right side cover. ([see par. 7.3](#))
4. Remove the left side cover. ([see par. 7.4](#))
5. Remove the Automatic Apparatus. ([see par. 7.7](#))

6. Disconnect the terminals from micro switch and motor.
7. Remove the five screws from the support.

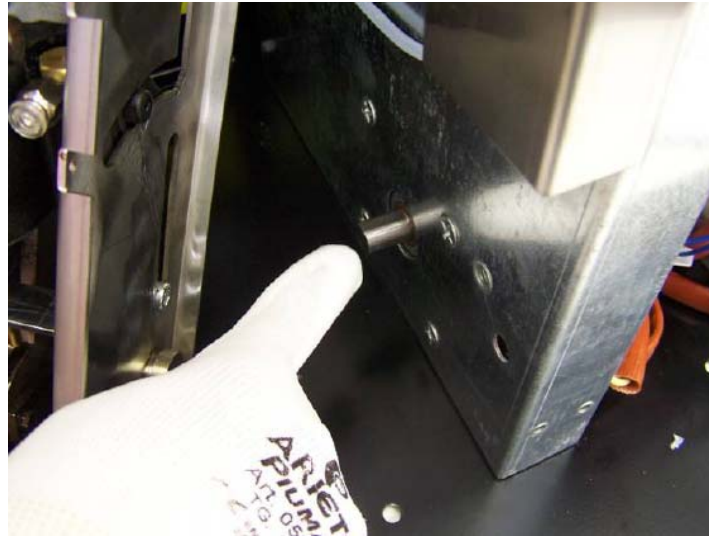

8. Remove the nut of pump support to facilitate the access moving the pump

- assembly sideways.
9. Then remove the gear motor group

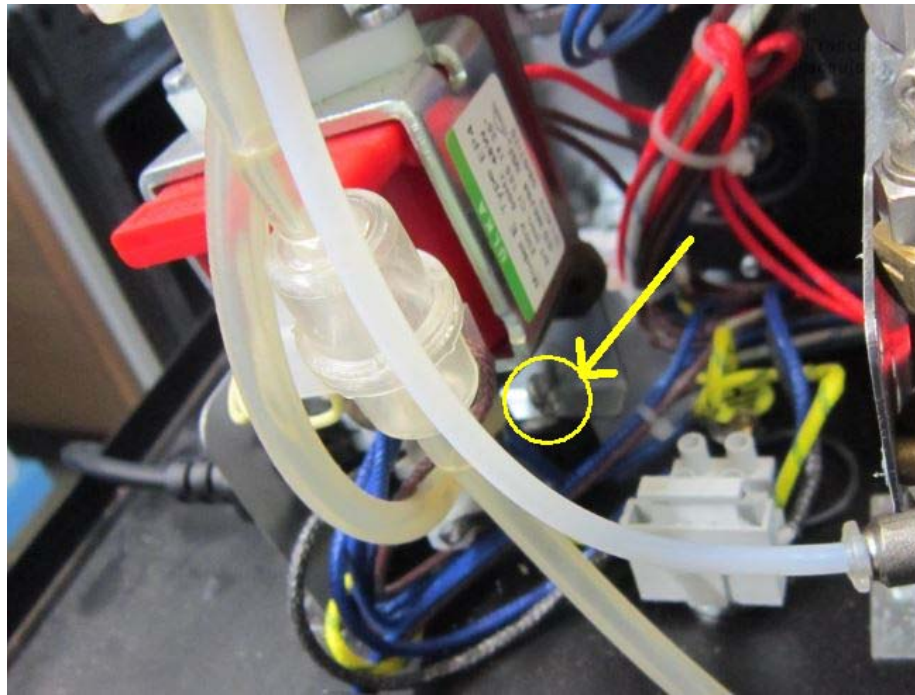

10. Replace the new one by reversing the previous steps.
11. Connect the terminals.
12. The connections must not be loose.
13. When fitting the automatic unit back on, be careful to correctly fit the pin of the same unit on the motor shaft as shown in the illustration.

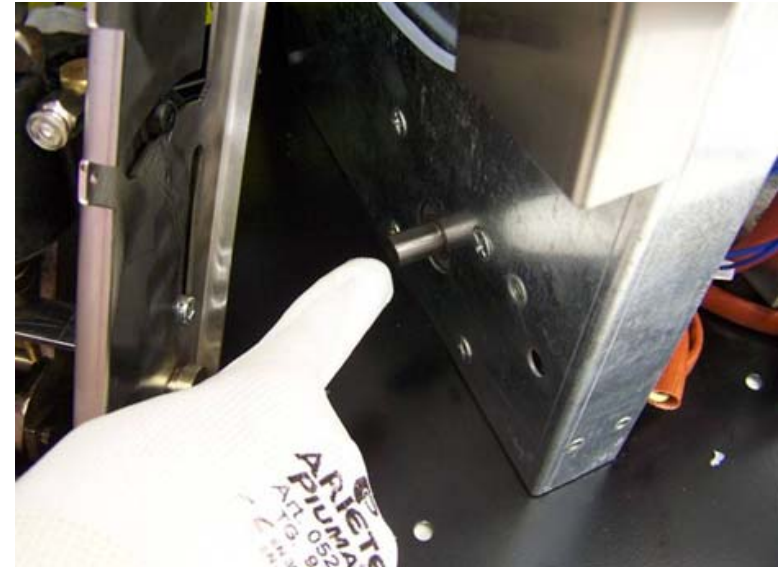
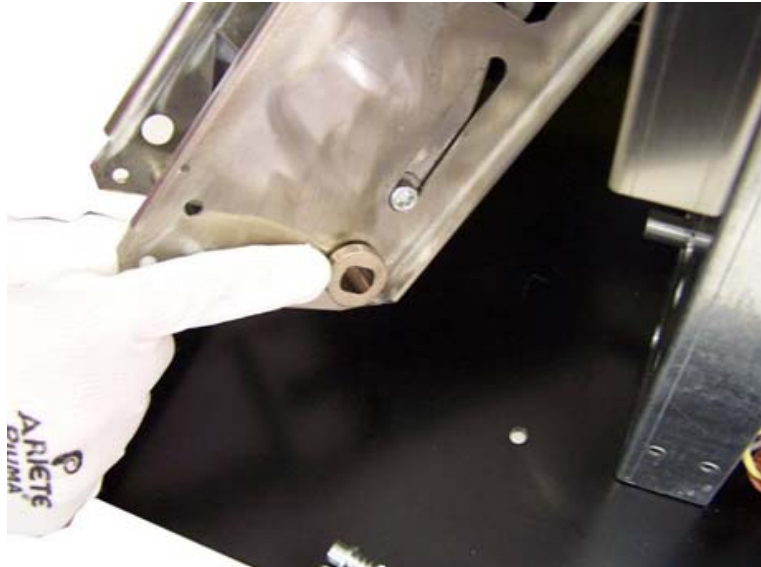

14. **IMPORTANT** Perform the setting of **AUTHOMATIC APPARATUS EXCHANGE** ([see Par. 7.9](#))

15. Reinstall the appliance into the cabinet.

16. Reconnect the power supply.
17. Run it and check all functions



1. Disconnect the power supply cord and remove the appliance from the cabinet. ([see par. 7.1](#))
2. Remove the upper cover. ([see par. 7.2](#))
3. Remove the left side cover. ([see par. 7.4](#))

This part is placed in the back rear side of the motor, under the grinder motor.
Here is shown the part we are talk about.

4. Dismount the gear motor CAM from the support by removing its central screw.

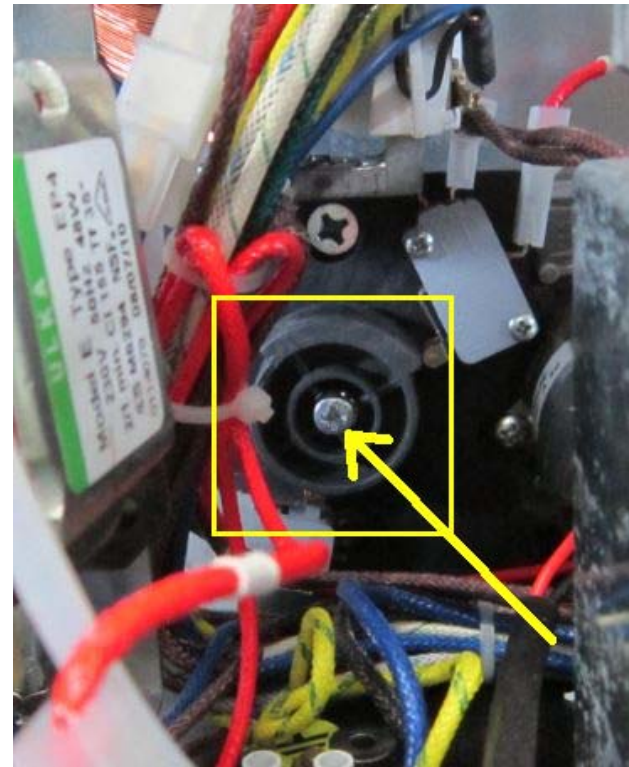

5. Turn on the machine, you may note that the motor start to turn.
6. Stop it, by the main switch placed in the back (A) when the apparatus is in the showed position.

NOTE: You may need to repeat this process. If you experience all the front led flashing (movement alarm signal), turn off the machine and turn it on again.

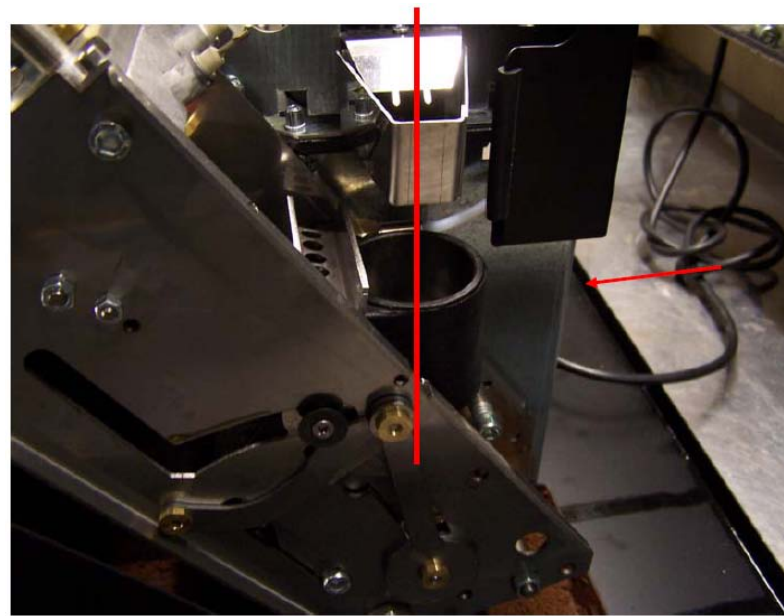

A

7. Assemble the gear motor CAM and rotate it by hand until the lower micro switch leverage contact is activated (see picture). (you listen “click”) and than fix it with the central screw.

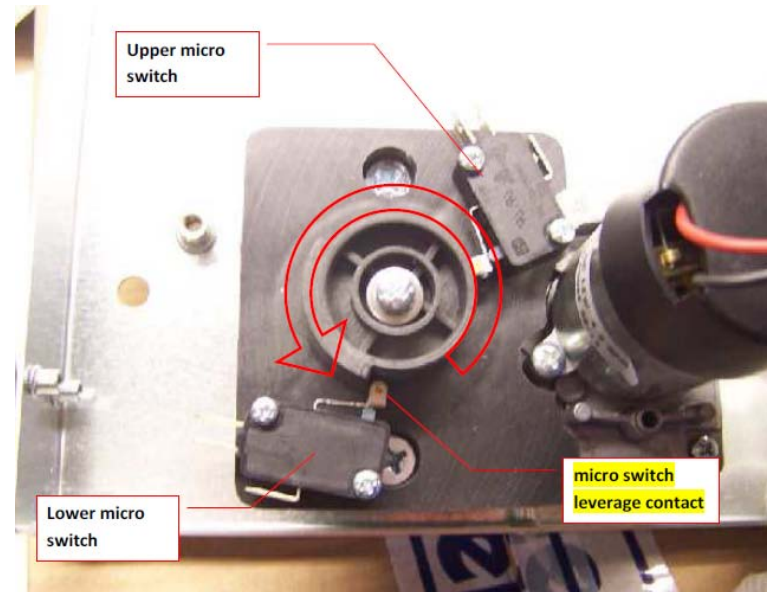

8. Turn on the machine, after two minutes, the apparatus go up. Check that all work in properly way thought the -**SERVICE DOOR**
Fig. 1 ([see par. 7.3](#))

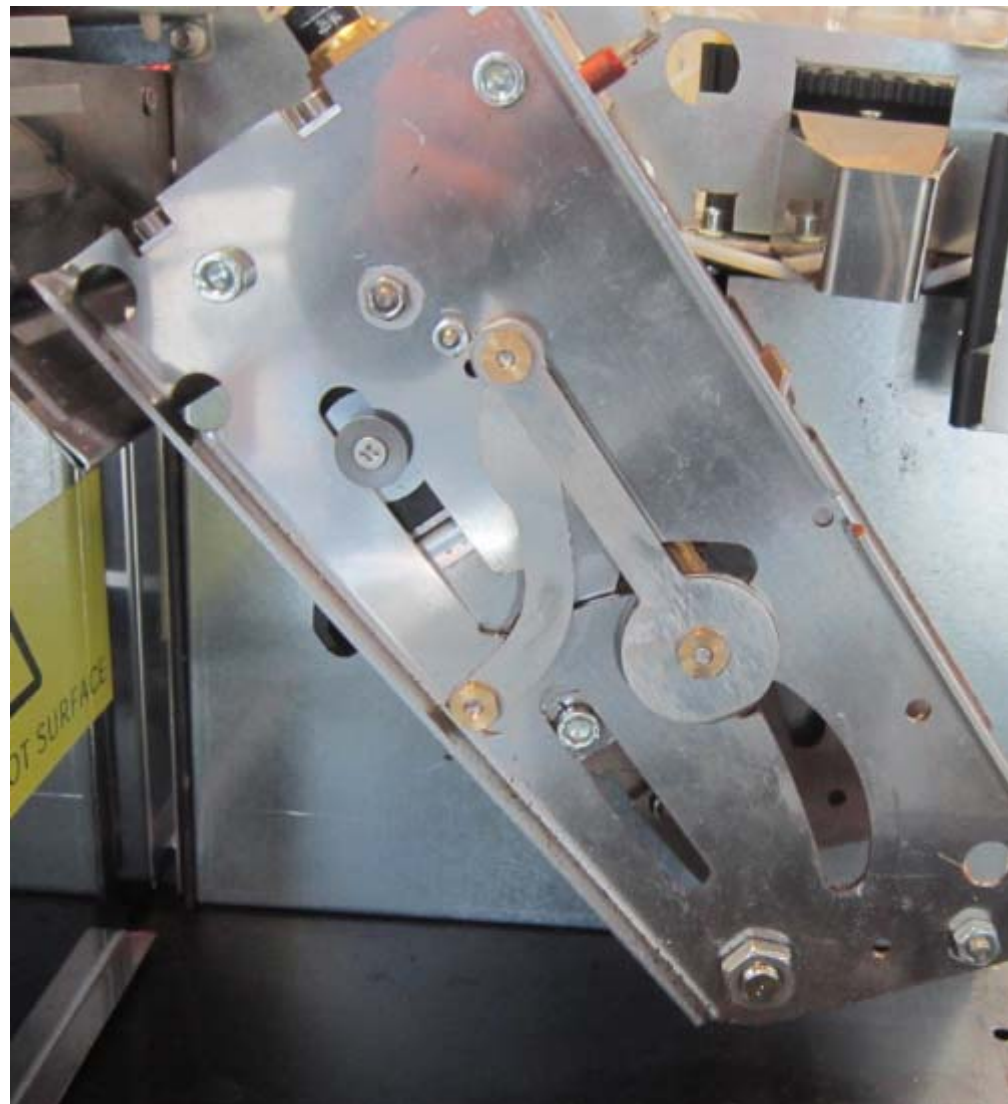

9. To verify the correct position check that the gap between central arm A and cross support B is 0.5mm by a piece of heavy paper.
10. If there is no gap of 0.5mm you have to perform adjustment of CAM following the previous steps.

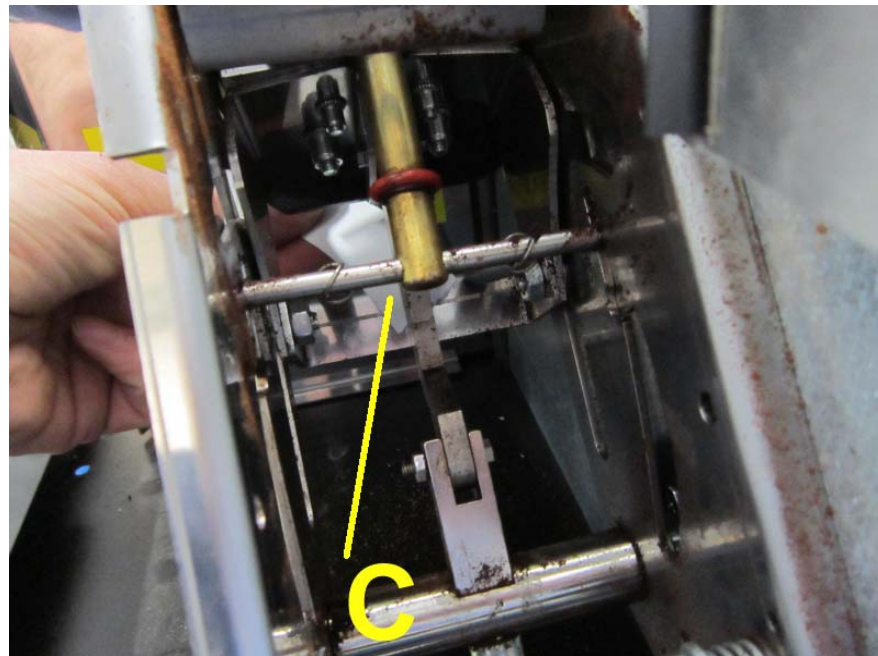
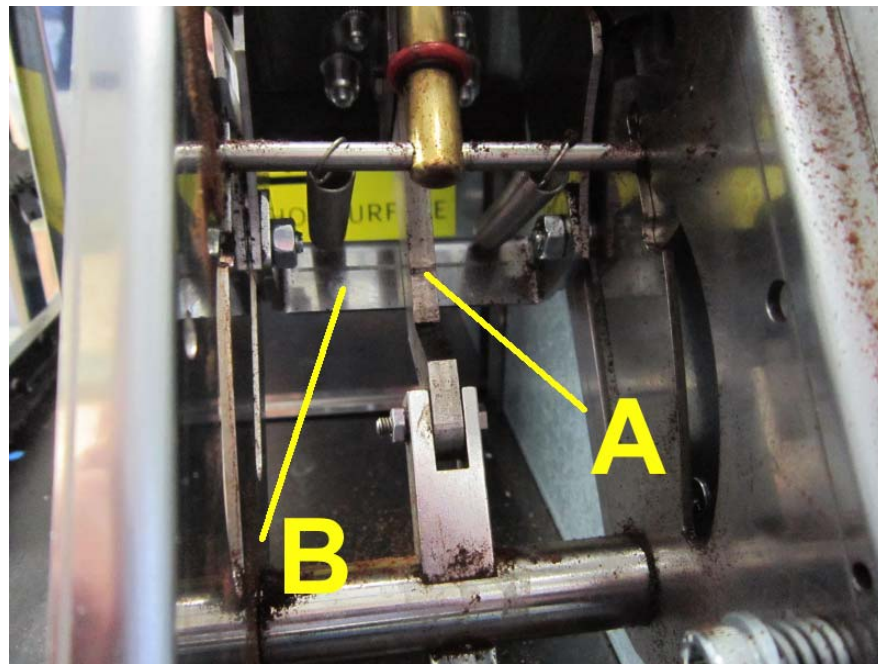



1. Disconnect the power supply cord and remove the appliance from the cabinet. ([see par. 7.1](#))
2. Remove the upper cover. ([see par. 7.2](#))
3. Remove the left side cover. ([see par. 7.4](#))

4. Lose the grain screw A and slide out the knob rod. the gear motor CAM from the support by removing its central screw.

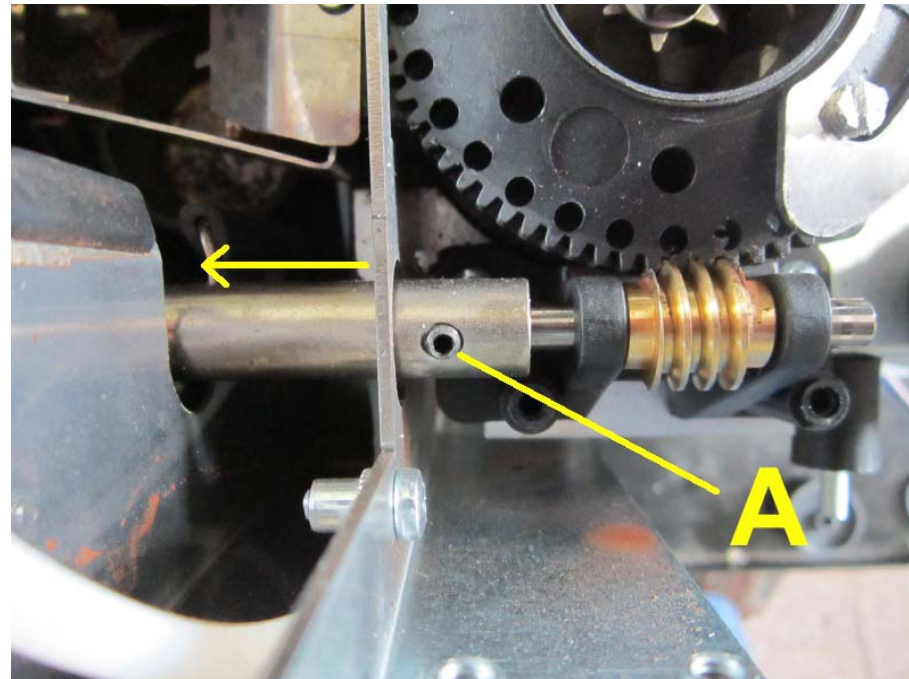

5. Disassemble the coffee funnel by removing the screw B.

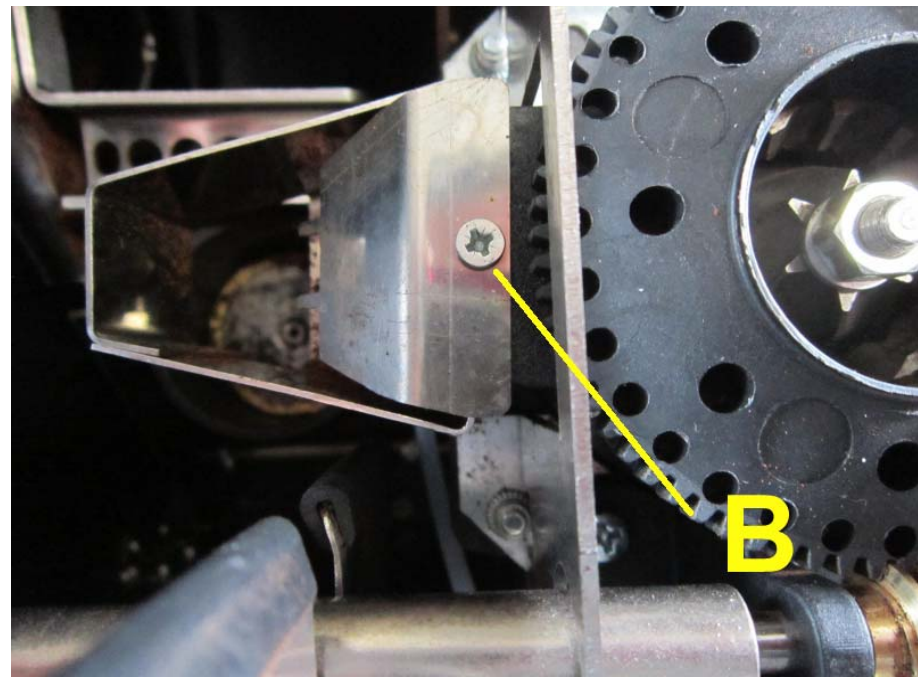

6. Unscrew the two screws from the grinder support. C & D.

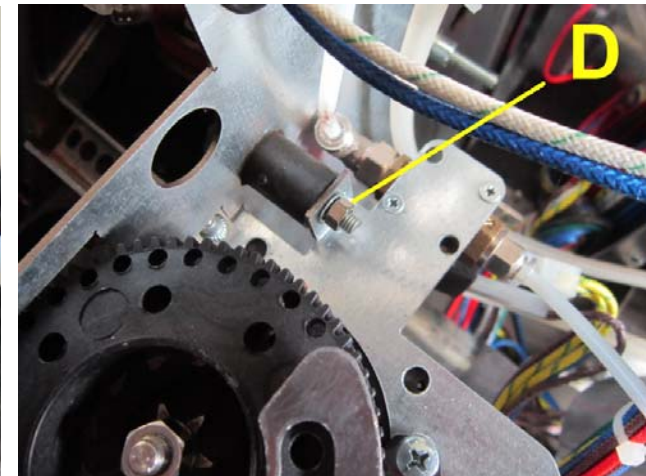
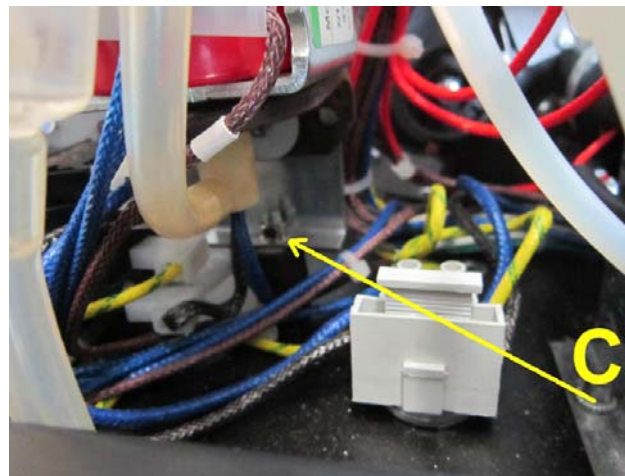

7. Unscrew the four screws from the grinder. E & F.

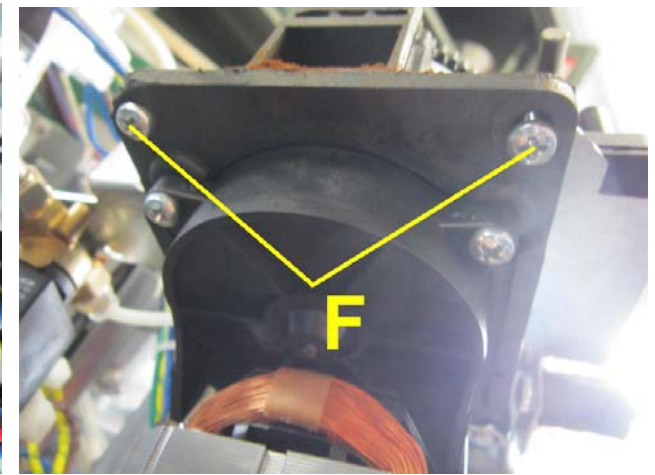
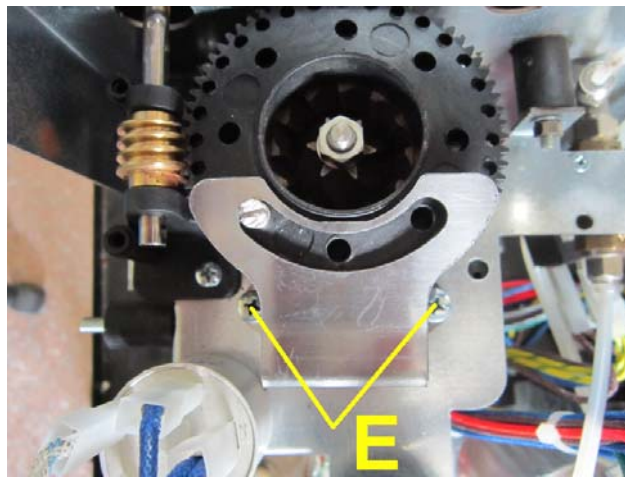

8. Disconnect the terminals from the bad grinder .
9. Replace the new one by reversing the previous steps.
10. Connect the terminals.
11. The connections must not be loose.
12. Reinstall the appliance into the cabinet.
13. Reconnect the power supply.
14. Run it and check all functions

Frontal Aesthetics substitution

1. Disconnect the power supply cord and remove the appliance from the cabinet. ([see par. 7.1](#))
2. Remove the upper cover. ([see par. 7.2](#))
3. Remove the right side cover. ([see par. 7.3](#))
4. Remove the left side cover. ([see par. 7.4](#))
5. Remove the DISPLAY BOARD. ([see par. 7.22](#))

6. Remove the screws showed in the pictures, two on the top and the others two under bottom platform .

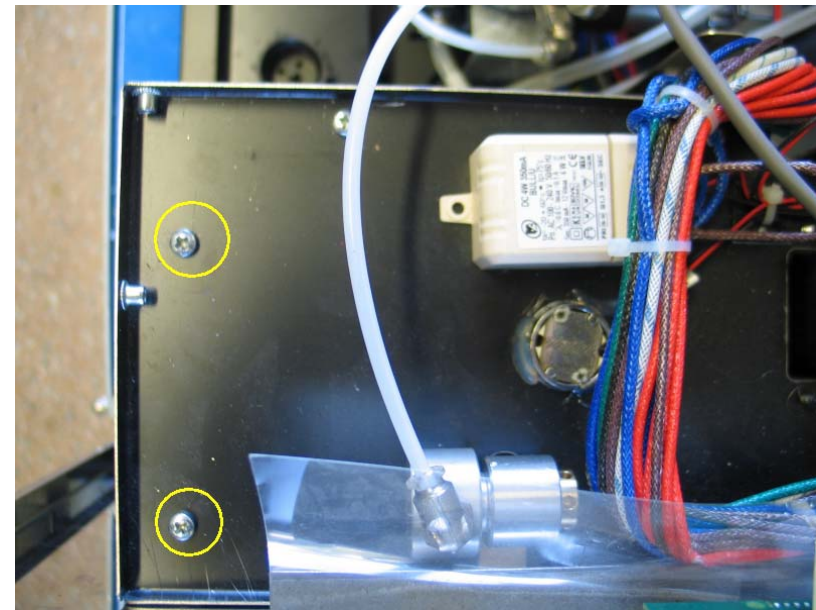
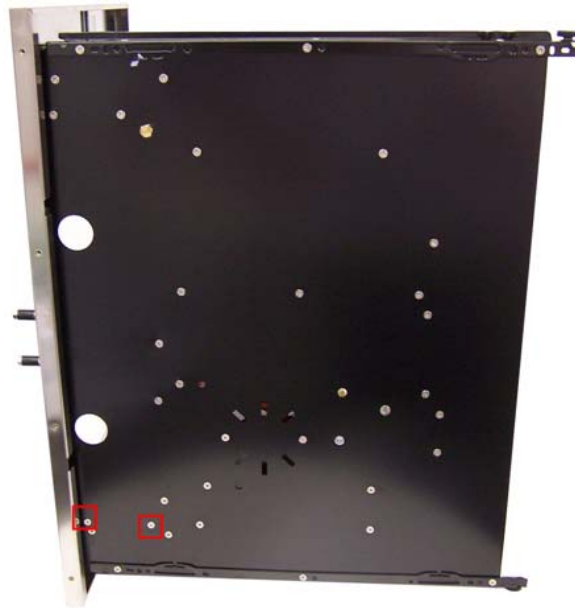

7. Remove the nuts showed in the pictures, two each side.

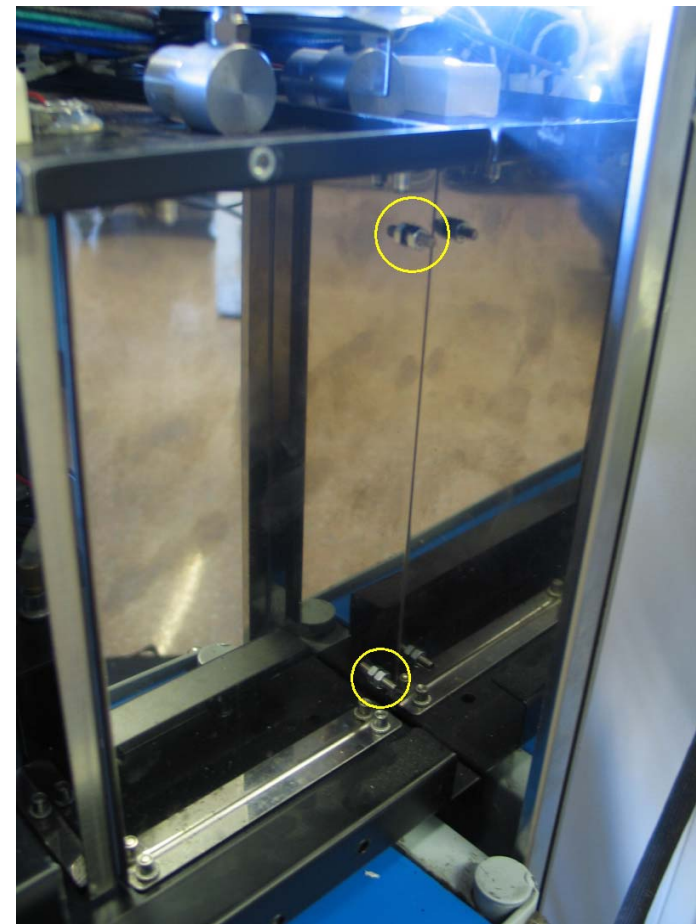
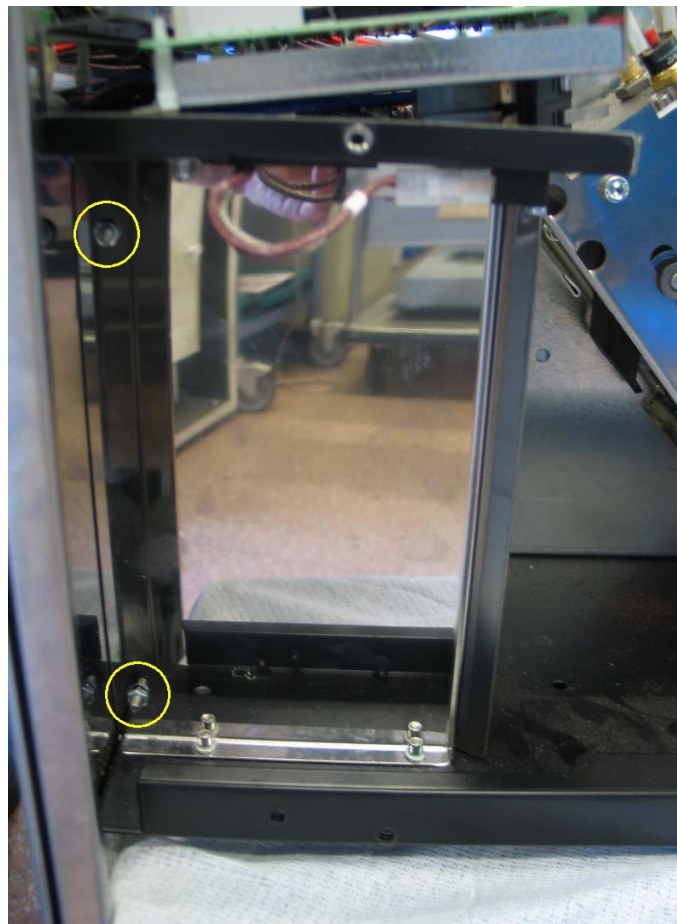

- 8.
- 9.
10. Extract the frontal aesthetic panel.
11. Replace the new one by reversing the previous steps.
12. Reassembly the display board connecting its cable ..
13. Reinstall the appliance into the cabinet.
14. Reconnect the power supply.
15. Run it and check all functions.

Water/steam dispensing nozzle substitution

1. Disconnect the power supply and slide out the appliance from the cabinet (is not necessary remove the appliance). ([see par. 7.1](#))
2. Remove the upper cover. ([see par. 7.2](#))
3. Disconnect the tube from its pipe A. ([Fig.1](#))
4. Unscrew the two screw B to remove the dispensing nozzle. ([Fig.2](#))
5. Replace the new one by reversing the previous steps.
6. Reinstall the appliance into the cabinet.
7. Reconnect the power supply.
8. Run it and check all functions.

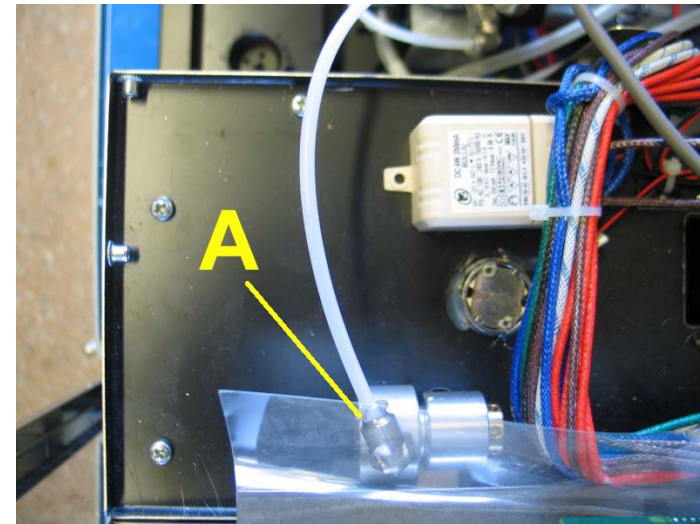

Fig.1

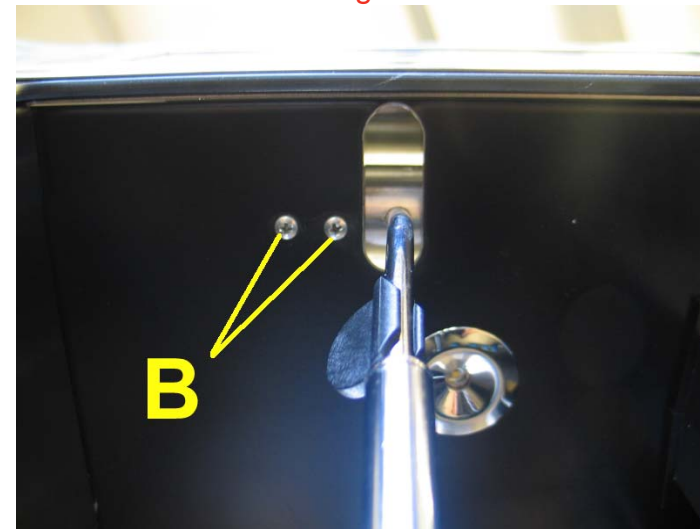
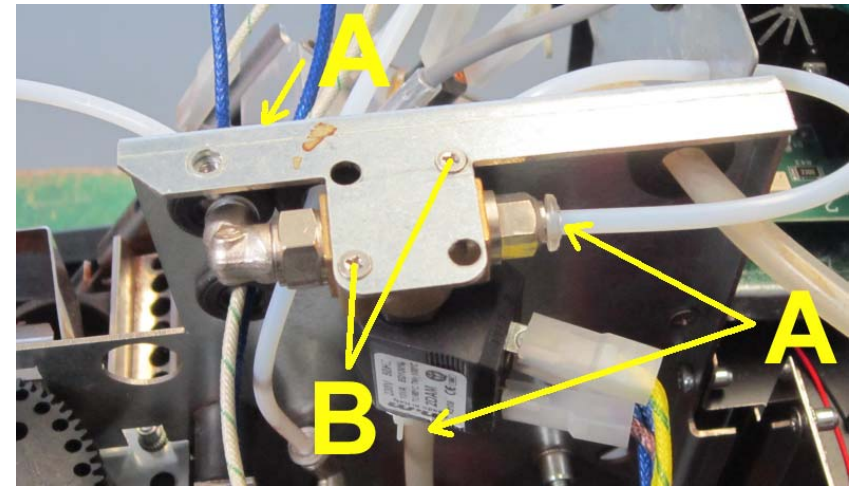

Fig.2

Coffee Solenoid Valves substitution

1. Disconnect the power supply cord and remove the appliance from the cabinet. ([see par. 7.1](#))
2. Remove the upper cover. ([see par. 7.2](#))
3. Disconnect the terminals from the valve.
4. Then disconnect the three PVC tubes from the pipes A.
5. Unscrew both screw B to remove the valve damaged.
6. Replace the new one by reversing the previous steps.
7. Connect the terminals.
8. The connections must not be loose.
9. Reinstall the appliance into the cabinet.
10. Reconnect the power supply.
11. Run it and check all functions.



Upper coffee solenoid valve

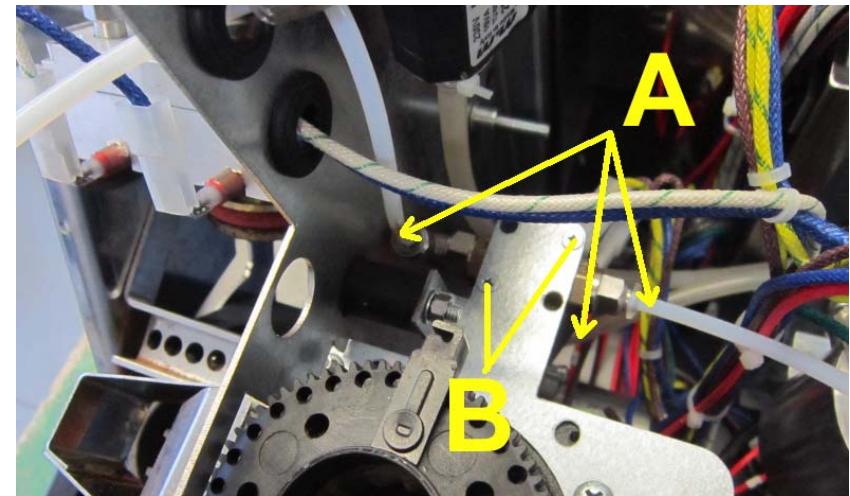

Lower coffee solenoid valve

Steam Solenoid Valve substitution

1. Disconnect the power supply cord and remove the appliance from the cabinet. ([see par. 7.1](#))
2. Remove the upper cover. ([see par. 7.2](#))
3. Remove the left side cover. ([see par. 7.4](#))
4. Disconnect the terminals from the valve.
5. Then disconnect the three PVC tubes from the pipes A.
6. Unscrew both screw B to remove the valve damaged.
7. Replace the new one by reversing the previous steps.
8. Connect the terminals.
9. The connections must not be loose.
10. Reinstall the appliance into the cabinet.
11. Reconnect the power supply.
12. Run it and check all functions.

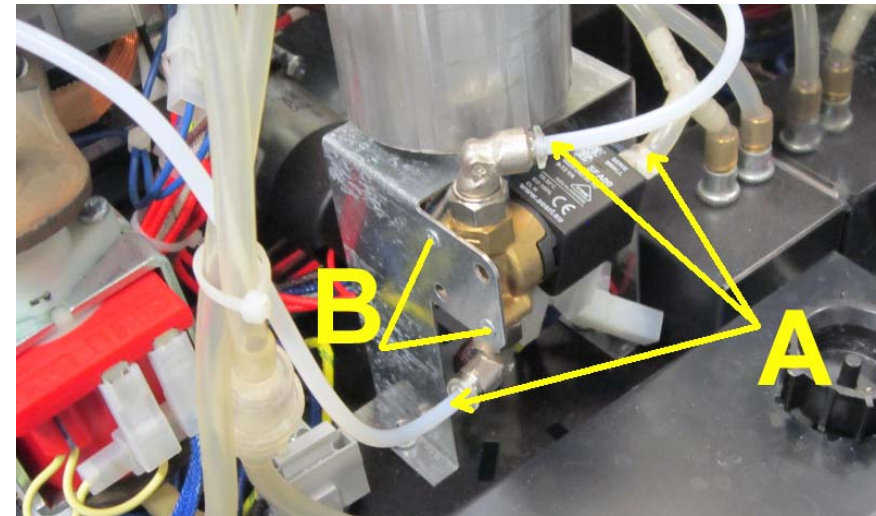

Steam solenoid valve

Water Counter substitution

1. Disconnect the power supply cord and slide out the appliance from the cabinet (is not necessary remove the appliance). ([see par. 7.1](#))
2. Remove the upper cover. ([see par. 7.2](#))
3. Disconnect the top connector A.
4. Than disconnect both PVC tubes from the pipes B.
5. Remove the water counter by its plastic clip placed under C
6. Replace the new one by reversing the previous steps.
7. Connect the connector and tubes in the same position.
8. Reinstall the appliance into the cabinet.
9. Reconnect the power supply.
10. Run it and check all functions.

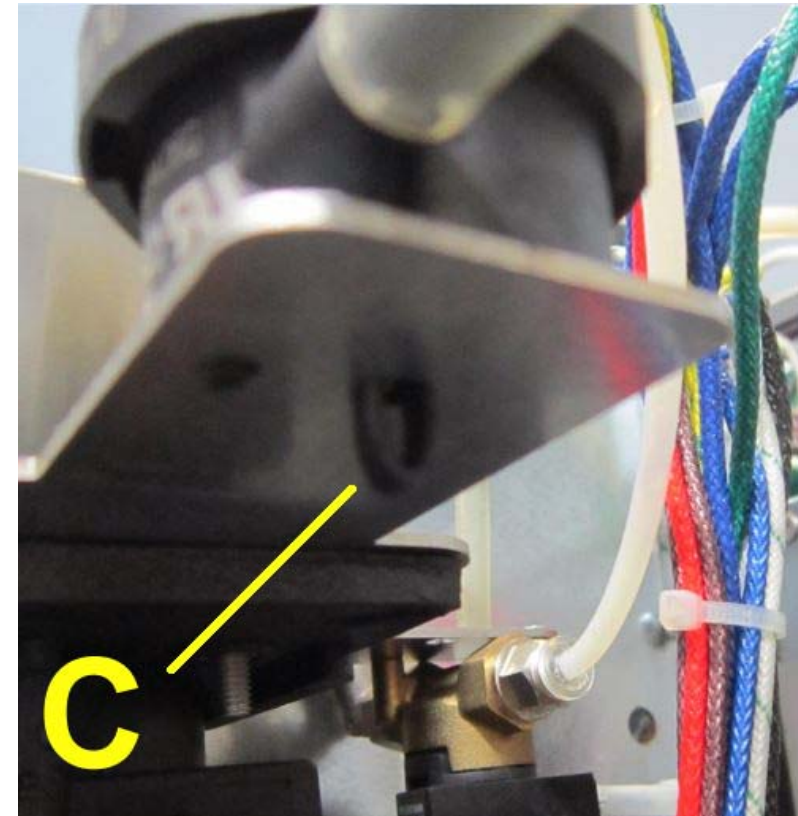
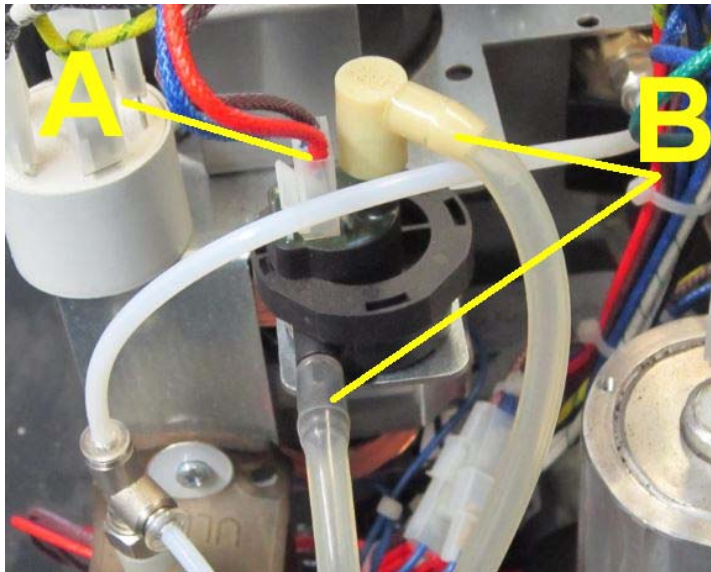

Interference Filter substitution

1. Disconnect the power supply cord and remove the appliance from the cabinet. ([see par. 7.1](#))
2. Remove the upper cover. ([see par. 7.2](#))
3. Remove the left side cover. ([see par. 7.4](#))
4. Disconnect the terminals on the top.
5. Remove the bottom nut and remove it.
6. Replace the new one by reversing the previous steps.
7. Connect the terminals in the same position.
8. The connections must not be loose.
9. Reinstall the appliance into the cabinet.
10. Reconnect the power supply.
11. Run it and check all functions.



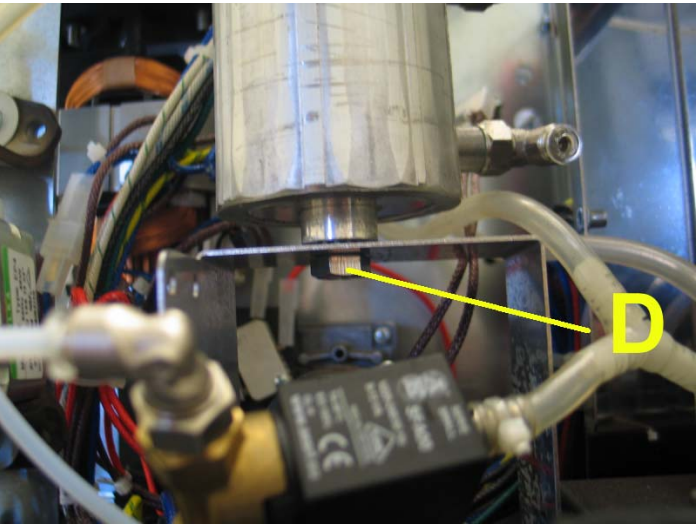

Led Transformer substitution

1. Disconnect the power supply and slide out the appliance from the cabinet (is not necessary remove the appliance). ([see par. 7.1](#))
2. Remove the upper cover. ([see par. 7.2](#))
3. Remove the transformer by its two screws A.
4. Than disconnect the wires.
5. Replace the new one by reversing the previous steps.
6. Connect the wires in the same position.
7. Reinstall the appliance into the cabinet.
8. Reconnect the power supply.
9. Run it and check all functions.

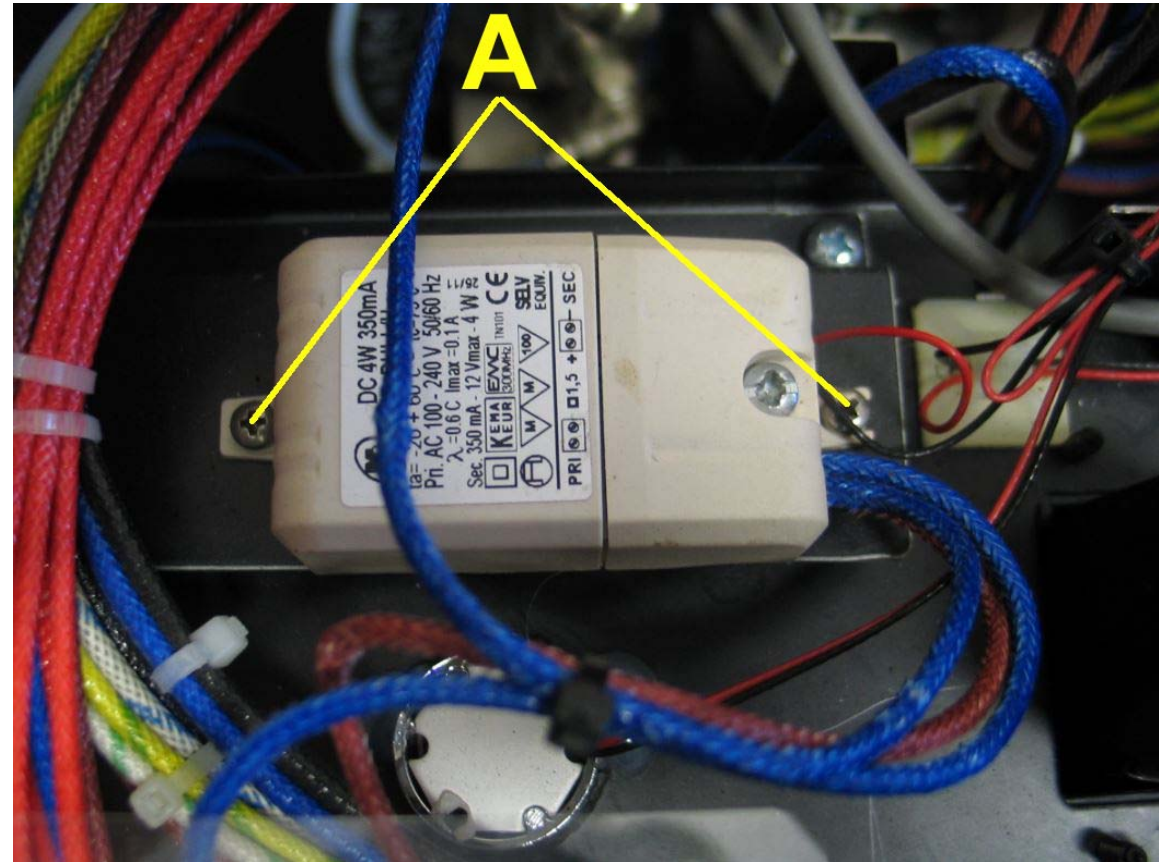



1. Disconnect the power supply and slide out the appliance from the cabinet (is not necessary remove the appliance). ([see par. 7.1](#))
2. Remove the upper cover. ([see par. 7.2](#))
3. Now depend which is the lamp damaged , if is the right one is necessary to remove also the Power Board ([see par. 7.23](#))
4. Disconnect the lamp wires from transformer.
5. Than cut the silicon around the to remove the lamp body ([fig.1](#)).
6. Replace the new lamp fixing it by silicon or glue gun.
7. Connect the wires.
8. Reinstall the appliance into the cabinet.
9. Reconnect the power supply.
10. Run it and check all functions.

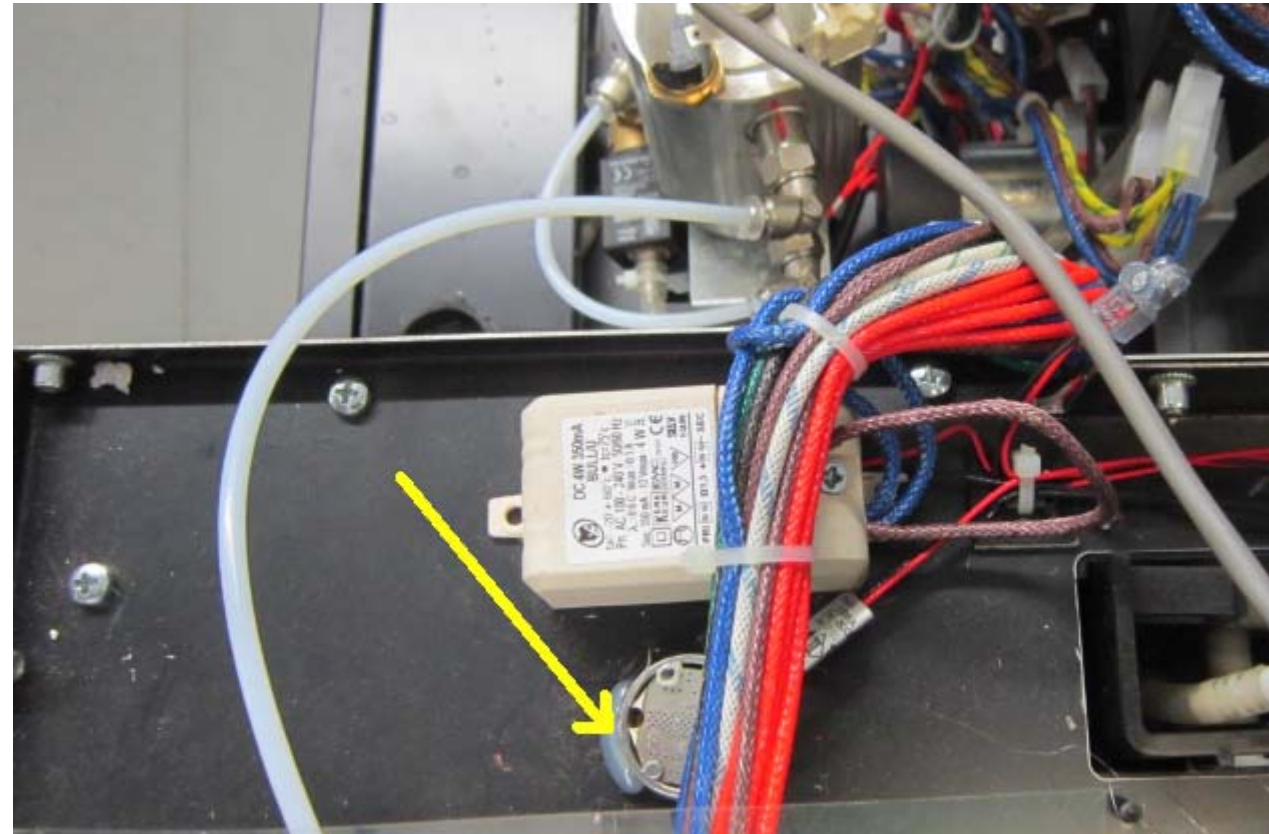

Fig.1

Safety Thermostats reset or substitution

1. Disconnect the power supply and slide out the appliance from the cabinet (is not necessary remove the appliance). ([see par. 7.1](#))
2. Remove the upper cover. ([see par. 7.2](#))
3. The two safety thermostats on the coffee exchanger ([Fig.2](#)) and on the steam/hot water exchanger ([Fig.1](#)) can be manually reset.
4. To reset, press the top button.
5. To remove them disconnect the terminals and then remove thermostats by unscrewing them.
6. Replace the new one by reversing the previous steps.
7. Reinstall the appliance into the cabinet.
8. Reconnect the power supply.
9. Run it and check all functions.

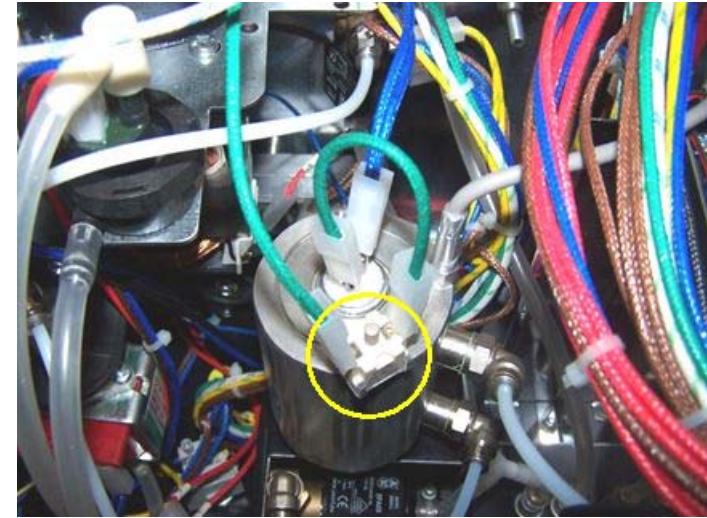

Fig.1

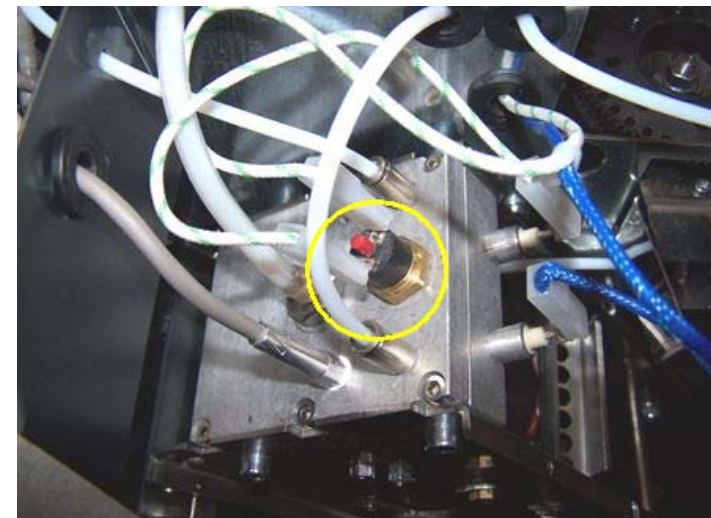

Fig.2

Main Fuse check or substitution

1. Disconnect the power supply and slide out the appliance from the cabinet (is not necessary remove the appliance). ([see par. 7.1](#))
2. Remove the upper cover. ([see par. 7.2](#))
3. The fuse is placed on the floor of the appliance.
4. Remove the fuse by its plastic support .
5. Replace the new one by reversing the previous steps.
6. Reinstall the appliance into the cabinet.
7. Reconnect the power supply.
8. Run it and check all functions.



Water Level Sensor substitution

1. Disconnect the power supply cord and remove the appliance from the cabinet. ([see par. 7.1](#))
2. Remove the upper cover. ([see par. 7.2](#))
3. Disconnect the terminals from the sensor cable.
4. Remove both sensor screw .
5. Replace the new one by reversing the previous steps.
6. Connect the terminals.
7. The connections must not be loose.
8. Reinstall the appliance into the cabinet.
9. Reconnect the power supply.
10. Run it and check all functions.

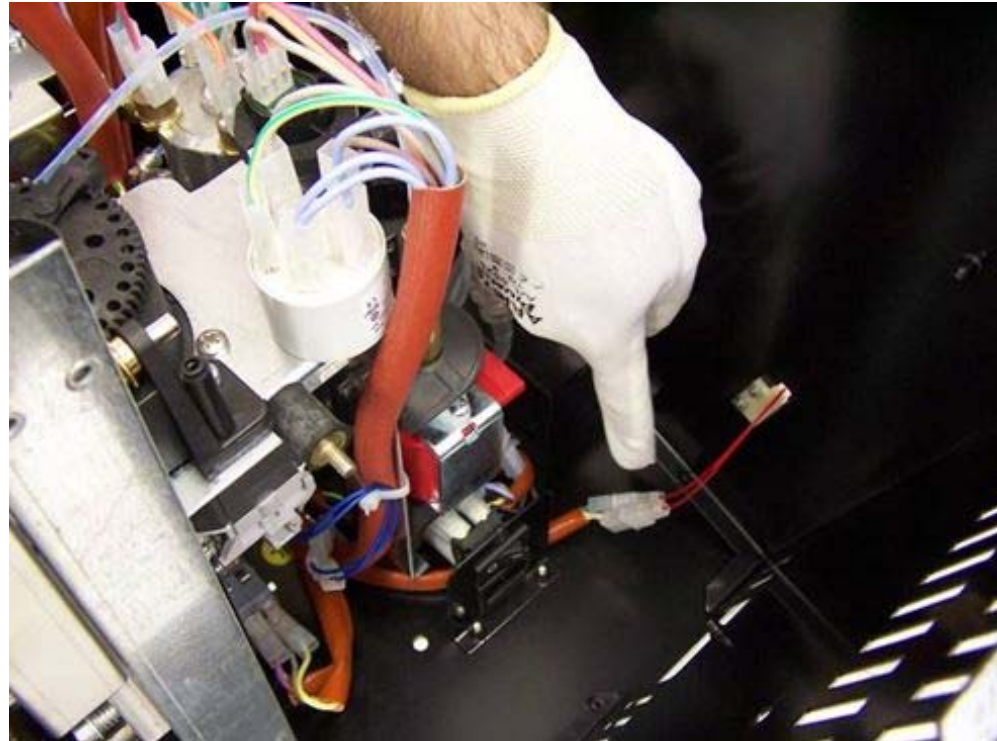



1. Disconnect the power supply and slide out the appliance from the cabinet (is not necessary remove the appliance). ([see par. 7.1](#))
2. Remove the upper cover. ([see par. 7.2](#))
3. Unhook the eight plastic spacers to remove display board. ([fig.1](#)).
4. Disconnect the connector A from display board.
5. Replace the new one by reversing the previous steps.
6. Reinstall the appliance into the cabinet.
7. Reconnect the power supply.
8. Run it and check all functions.

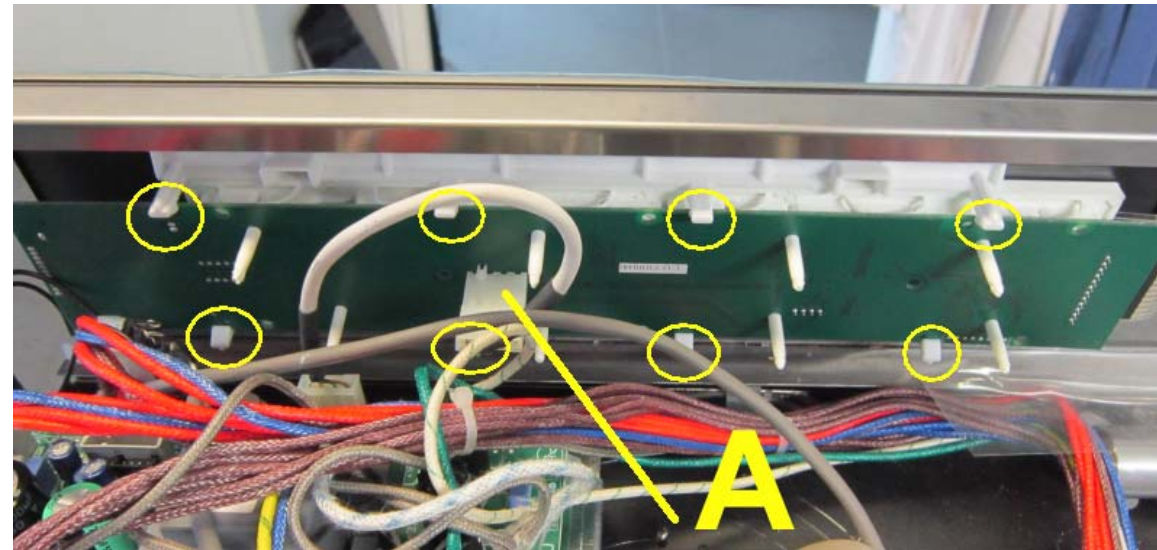

Fig.1

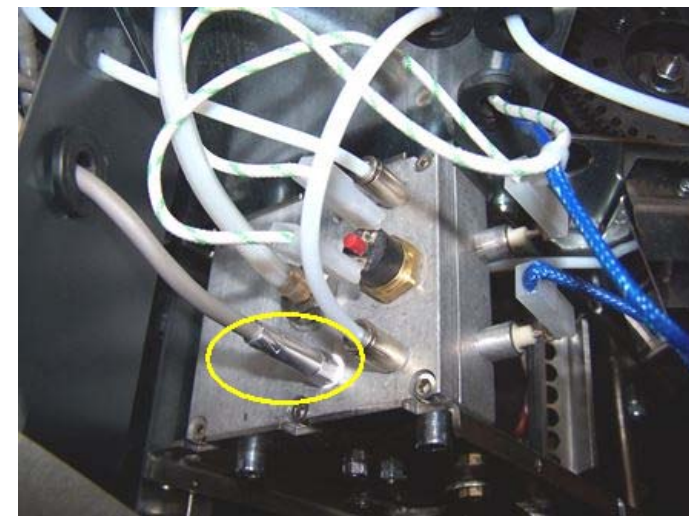

Fig.2

Power Board & Fuses substitution

1. Disconnect the power supply and slide out the appliance from the cabinet (is not necessary remove the appliance). (see par. 7.1)
 2. Remove the upper cover. (see par. 7.2)
 3. Remove the plastic spacer connecting the power board before disconnecting the cables (fig.1).
 4. Replace the new power board using the same spacers.
 5. Connect the cable following the electric diagram.
 6. **IT IS VERY IMPORTANT TO CONNECT THE CABLES IN THE RIGHT POSITION.**
 7. The connections must not be loose.
 8. Reinstall the appliance into the cabinet.
 9. Reconnect the power supply.
 10. Run it and check all functions.
-
11. To check the Power Board fuses remove the caps by a blade screw driver (fig.2).
 - A Pump Fuse
 - B Grinder Fuse
 12. In case one of these is interrupted replace it with another with the same ratings.

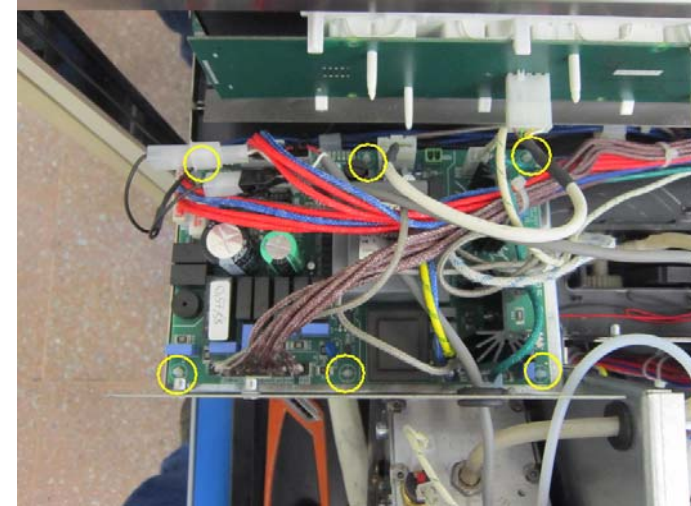

Fig.1

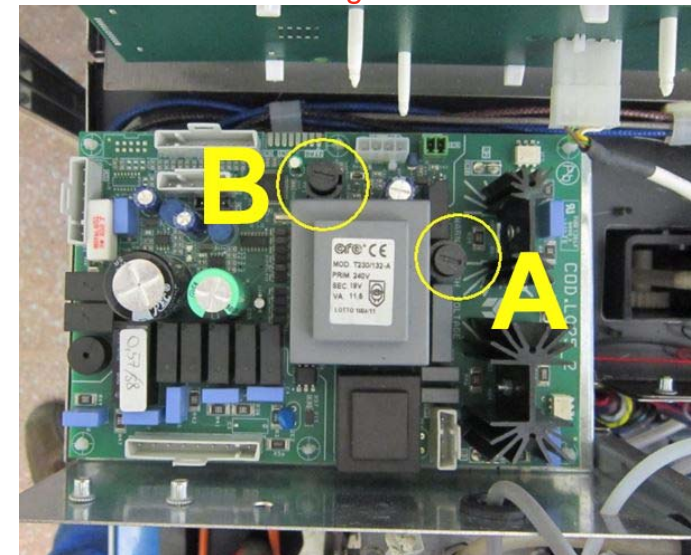

Fig.2



1. Disconnect the power supply and slide out the appliance from the cabinet (is not necessary remove the appliance). ([see par. 7.1](#))
2. Remove the upper cover. ([see par. 7.2](#))
3. The two safety thermostats on the coffee exchanger ([Fig.2](#)) and on the steam/hot water exchanger ([Fig.1](#)).
4. To remove them disconnect the terminals from power board and then remove NTC by unscrewing them.
5. Replace the new one by reversing the previous steps.
Note: Do not tighten with excessive force to prevent damage of the NTC.
6. Reinstall the appliance into the cabinet.
7. Reconnect the power supply.
8. Run it and check all functions.



Fig.1

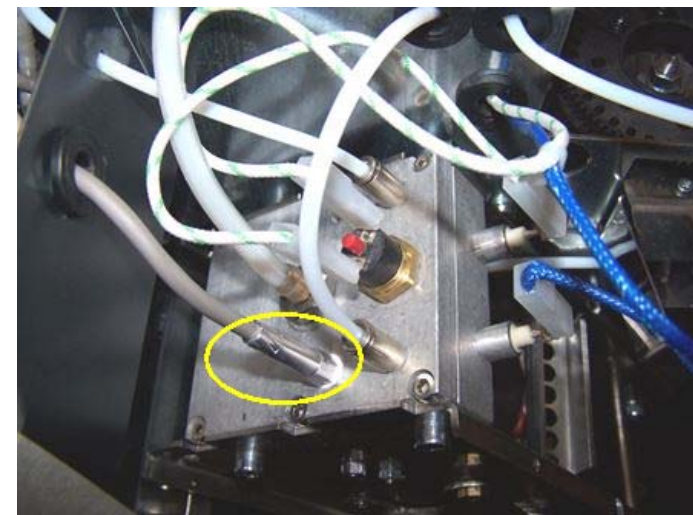

Fig.2

Micro Switches substitution

1. Disconnect the power supply and slide out the appliance from the cabinet (is not necessary remove the appliance). [\(see par. 7.1\)](#)
2. Remove the upper cover. [\(see par. 7.2\)](#)
3. Remove the right side cover. [\(see par. 7.3\)](#)
4. The photo [\(Fig.1\)](#) shows the micro switch of the door and dredge unloading. The micro also sends a signal to the board for dredge count reset.
5. The photo [\(Fig.2\)](#) shows the two micro switches of the side door. These disconnect the entire power circuit downstream of the master switch.
6. To remove them disconnect the terminals and then remove the bad micro switch unscrewing its screws.
7. Replace the new one by reversing the previous steps.
8. Reinstall the appliance into the cabinet.
9. Reconnect the power supply.
10. Run it and check all functions.

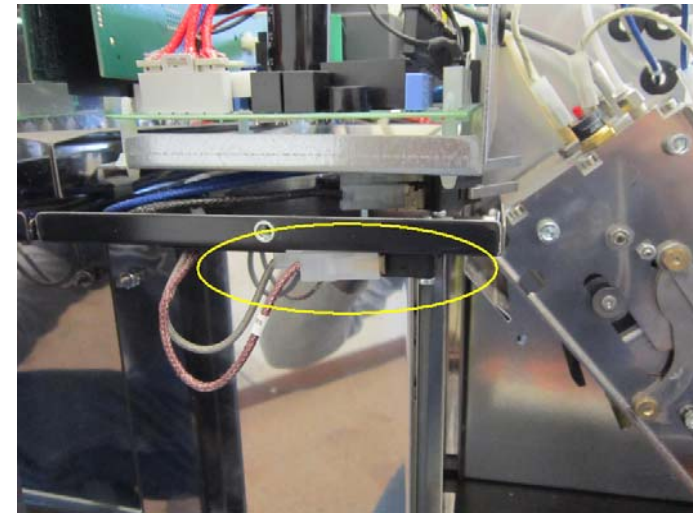

Fig.1

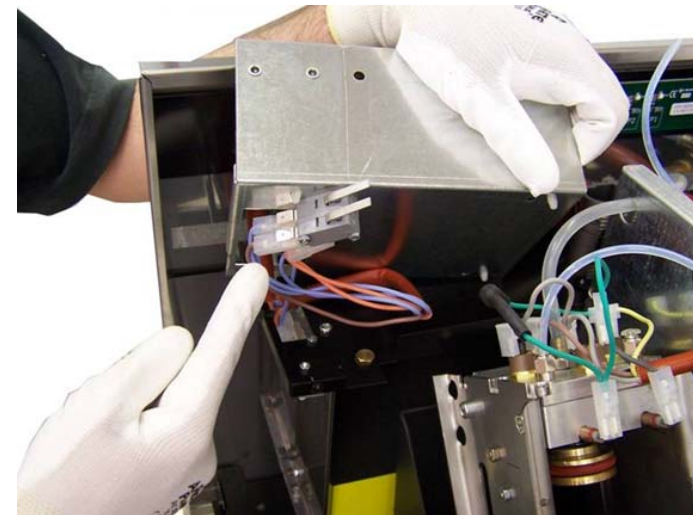

Fig.2

Main Switch substitution

1. Disconnect the power supply and slide out the appliance from the cabinet (is not necessary remove the appliance). ([see par. 7.1](#))
2. Remove the screw showed in the picture ([Fig.1](#)) .
3. Unscrew also the two from the bottom to remove the switch support ([Fig.2](#)) .
4. Disconnect the terminals and then replace the new one by reversing the previous steps.
5. Reinstall the appliance into the cabinet.
6. Reconnect the power supply.
7. Run it and check all functions.

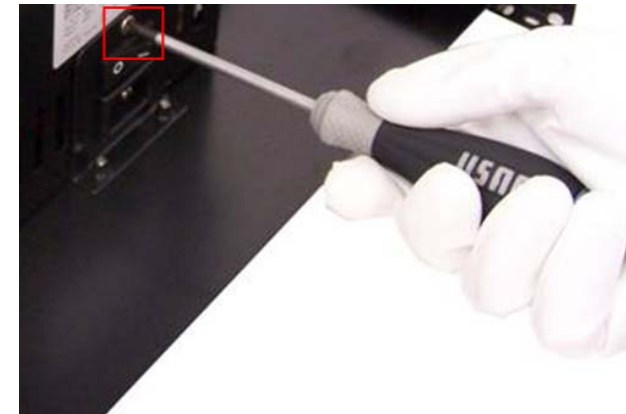

Fig.1

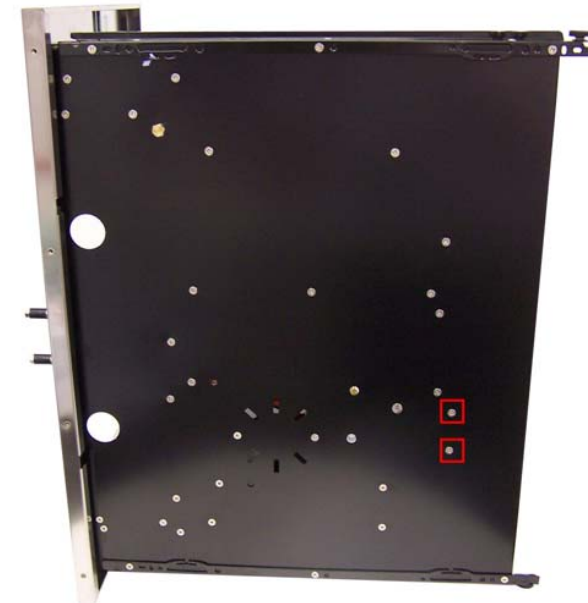

Fig.2

Unlocking Lever System substitution

1. Remove the drip basin from its seat.
2. Press the unlocking lever under the drip basin and pull the machine towards you. **(Fig.1)**
3. Unscrew the five screws to remove the leverage nozzle. **(Fig.2)**
4. Replace the new one by reversing the previous steps.
5. Reinstall the appliance into the cabinet.
6. Reconnect the power supply.
7. Run it and check all functions.

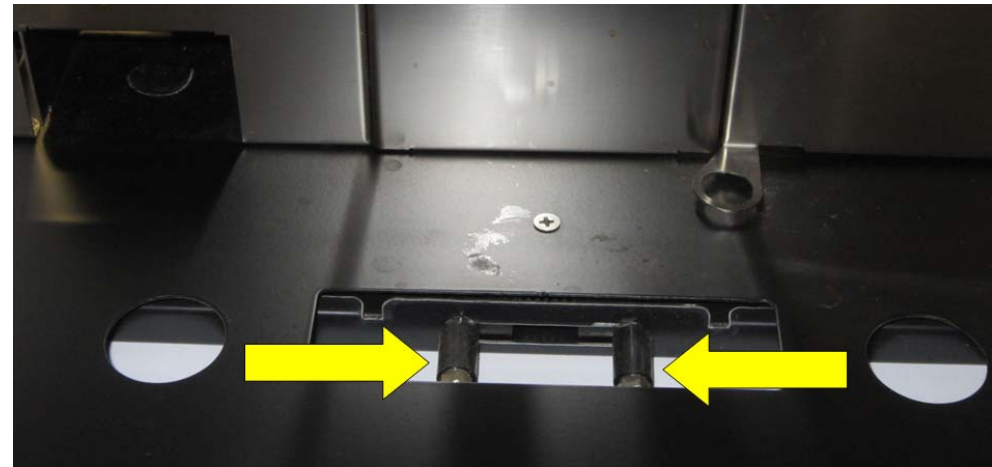

Fig.1

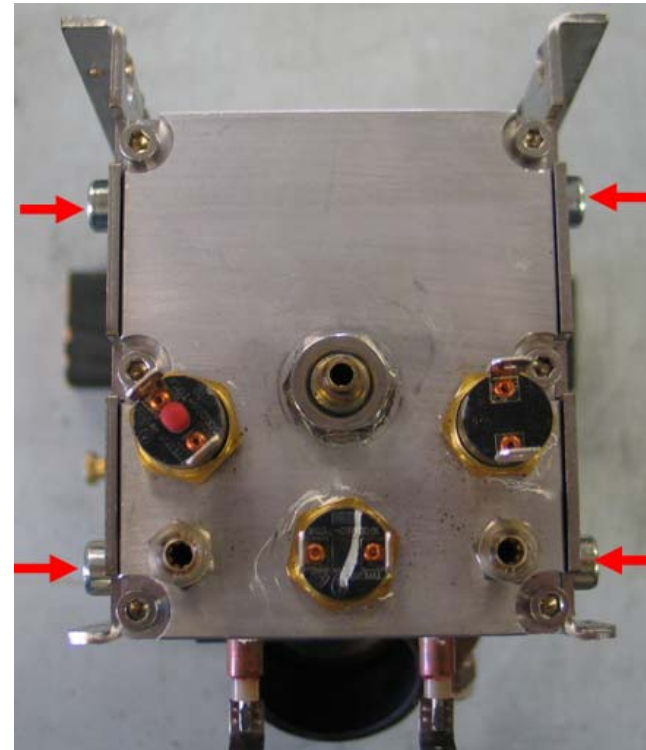

Fig.2



1. Disconnect the power supply cord and remove the appliance from the cabinet.
([see par. 7.1](#))
2. Remove the Automatic Apparatus. ([see par. 7.7](#))

3. Remove the coffee heater by the its four screws.



4. Remove the nut of buffer and remove it sliding out.

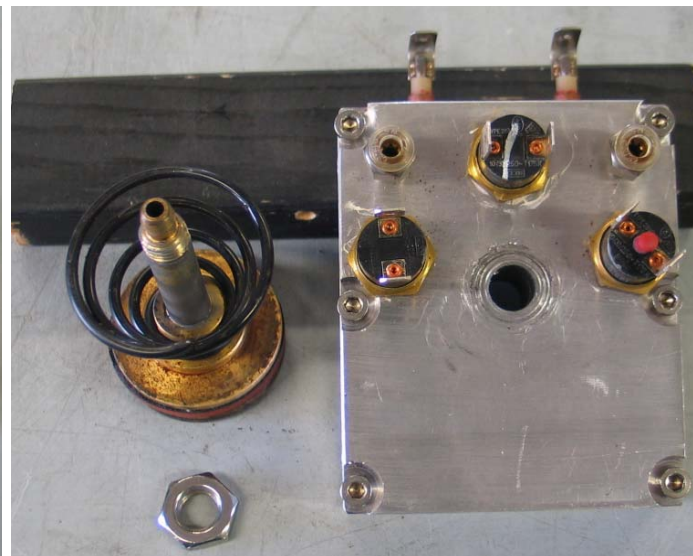
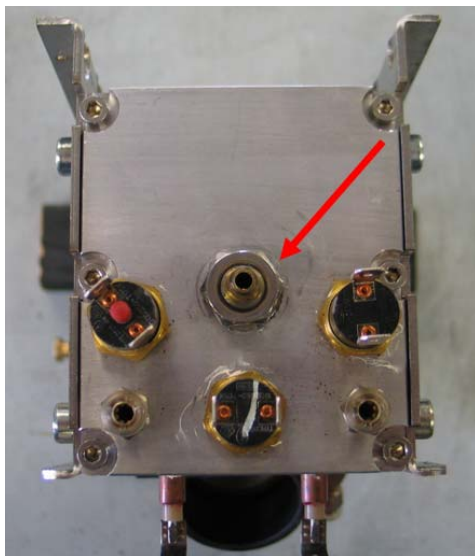

5. Replace the new one by reversing the previous steps.
6. Connect the terminals.
7. The connections must not be loose.
8. When fitting the automatic unit back on, be careful to correctly fit the pin of the same unit on the motor shaft as shown in the illustration.

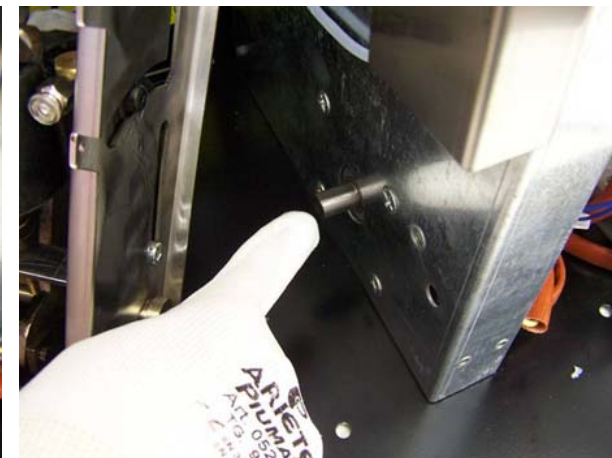
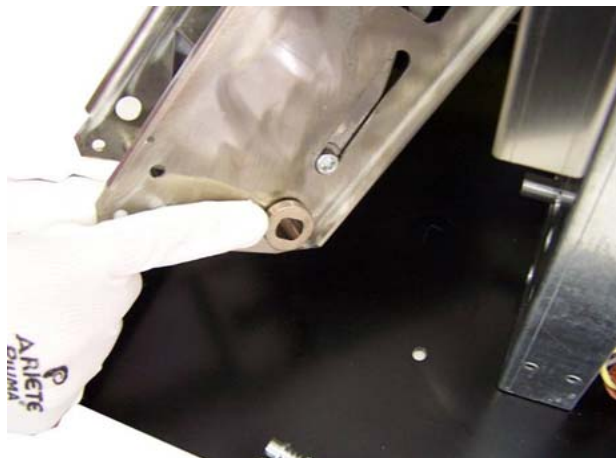

9. Reinstall the appliance into the cabinet.
10. Reconnect the power supply.
11. Run it and check all functions

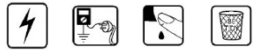
Buffer's gasket and filter substitution

1. Disconnect the power supply cord and remove the appliance from the cabinet. ([see par. 7.1](#))
2. Remove the Automatic Apparatus. ([see par. 7.7](#))

3. Remove the coffee heater by the its four screws.

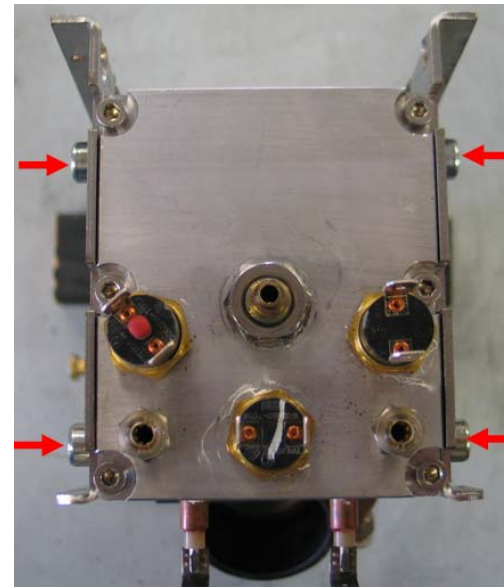

4. If is necessary to replace the buffer spring
Remove the nut of buffer and remove it sliding out.

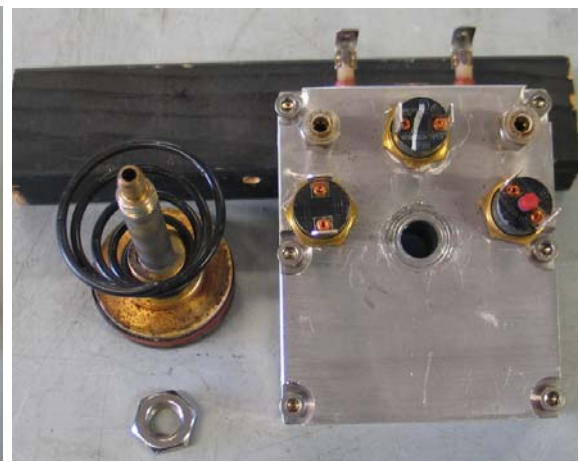
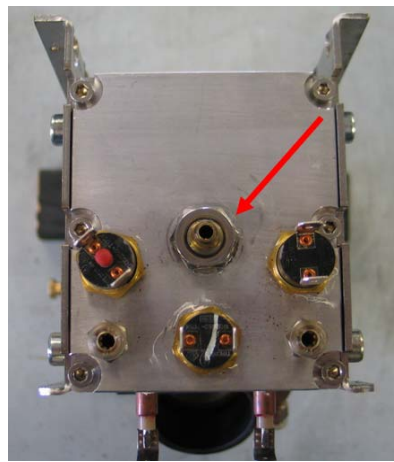

5. To replace the filter remove it by its screw.

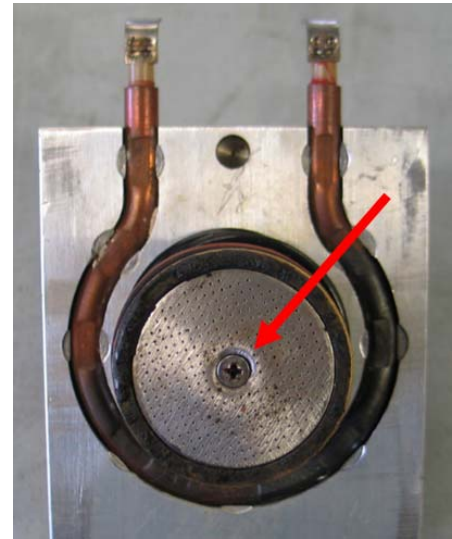

6. To replace the gasket remove it from the buffer.

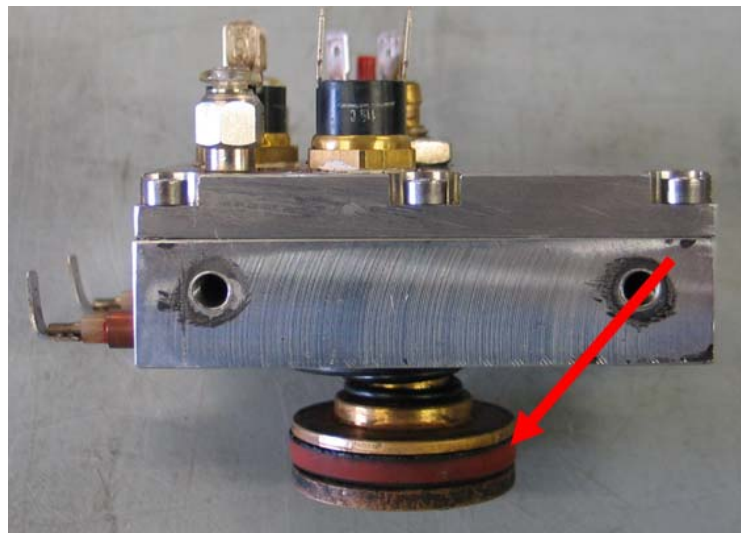

7. Replace the new one by reversing the previous steps.
8. Connect the terminals.
9. The connections must not be loose.
10. When fitting the automatic unit back on, be careful to correctly fit the pin of the same unit on the motor shaft as shown in the illustration.

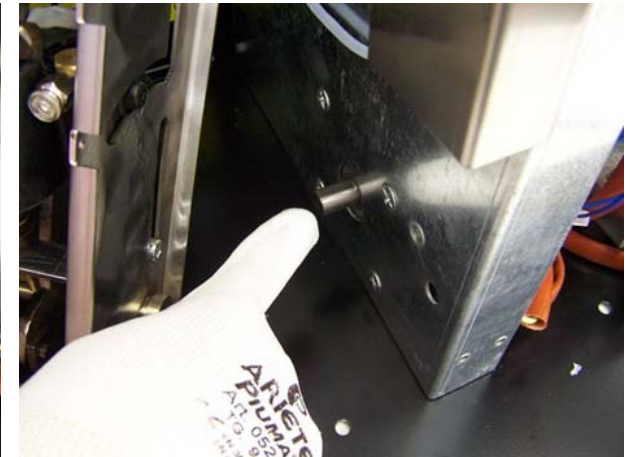
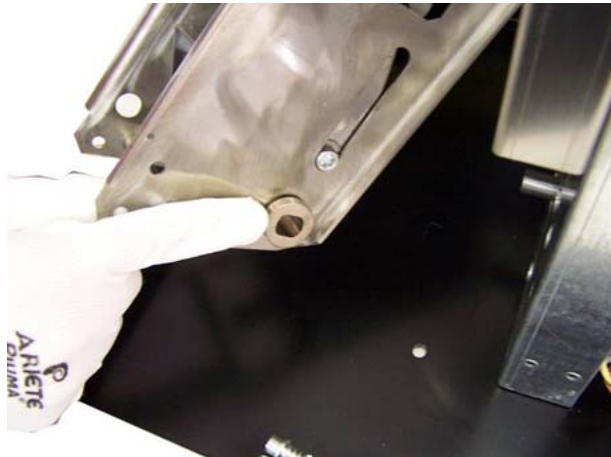

11. Reinstall the appliance into the cabinet.
12. Reconnect the power supply.
13. Run it and check all functions

Coffee cup's gasket and filter substitution

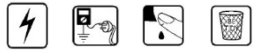

1. Disconnect the power supply cord and remove the appliance from the cabinet. ([see par. 7.1](#))

1. Remove the upper cover. ([see par. 7.2](#))

2. Remove the coffee filter by the its central screw and replace it.

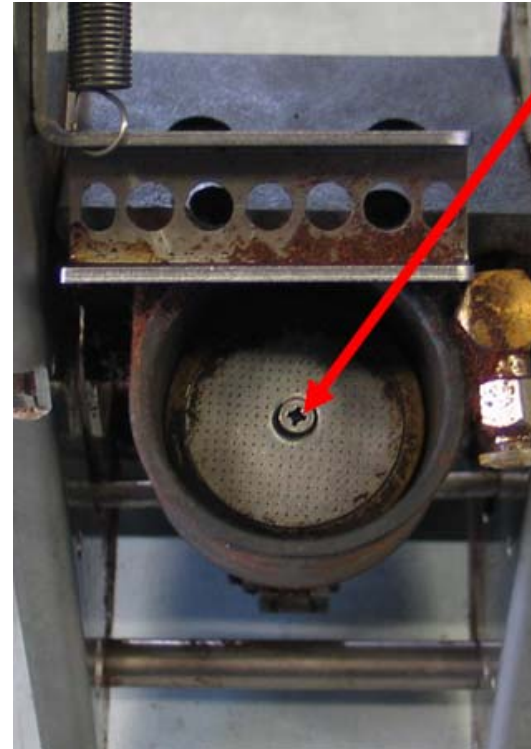

3. If is necessary to replace the gasket of filter support remove it sliding out.



4. To replace the gasket remove it from the support.



5. Reassemble all parts by reversing the previous steps.
6. Reinstall the appliance into the cabinet.
7. Reconnect the power supply.
8. Run it and check all functions

Gasket of Coffee Cup spindle substitution



1. Disconnect the power supply cord and remove the appliance from the cabinet. [\(see par. 7.1\)](#)
2. Remove the Automatic Apparatus. [\(see par. 7.7\)](#)

3. Remove the coffee filter.

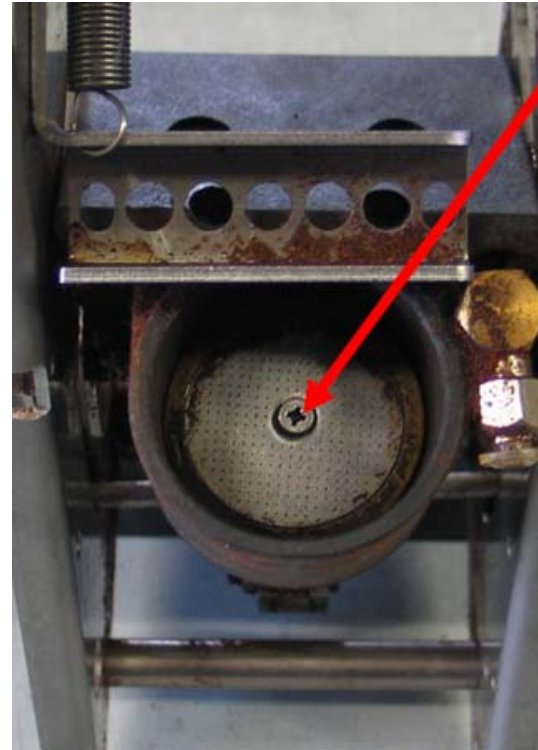

4. Remove the filter support sliding it out.

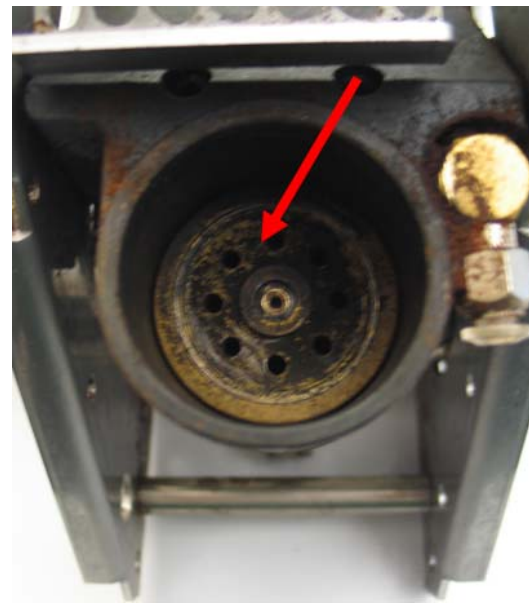

5. To remove the spindle is necessary to unscrew the nut showed and then slide out the **round support** and following the **cup spindle**.

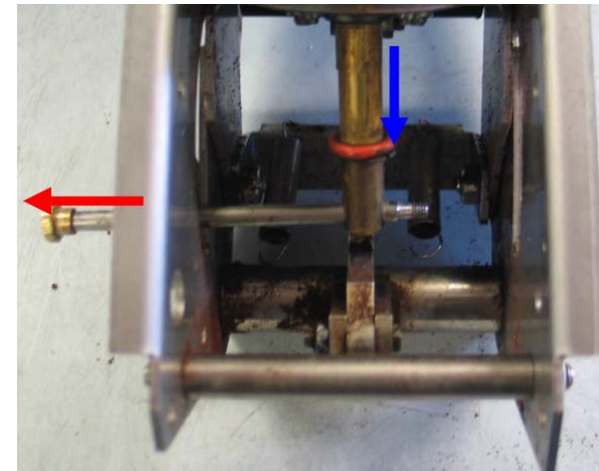

6. Replace both gasket s.

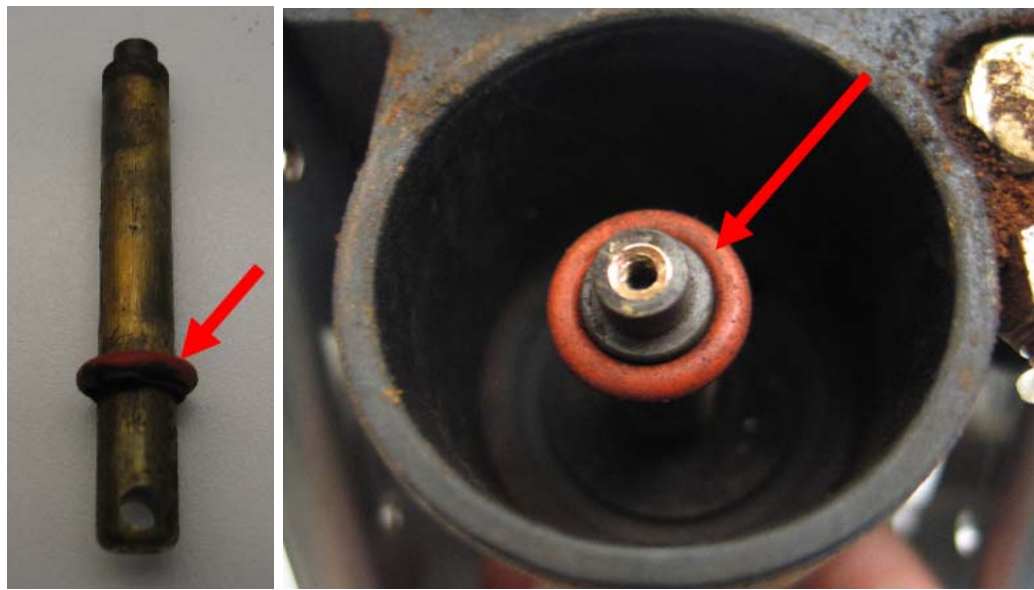

7. Replace all parts by reversing the previous steps.
8. Connect the terminals.
9. The connections must not be loose.
10. When fitting the automatic unit back on, be careful to correctly fit the pin of the same unit on the motor shaft as shown in the illustration.

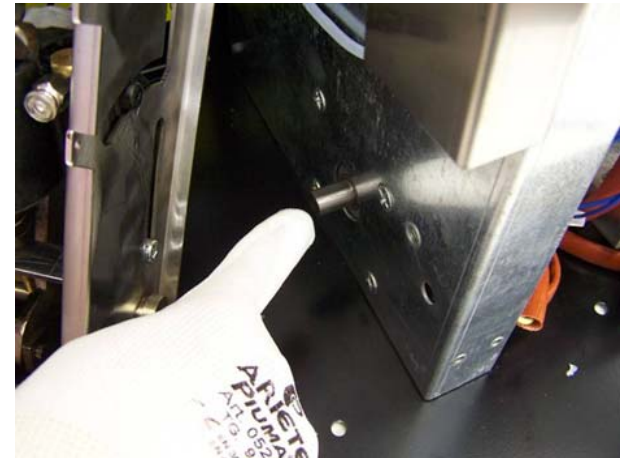
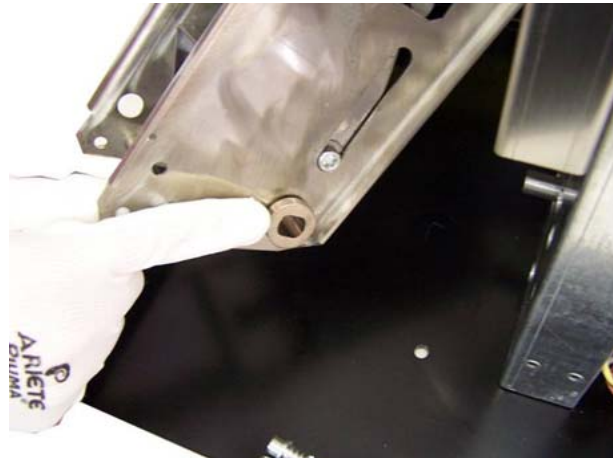

11. Reinstall the appliance into the cabinet.
12. Reconnect the power supply.
13. Run it and check all functions