



WC6530

Caple Fully Built-in Wine Cabinet



Technical Manual



WC6530

Cable Fully Built-in Wine Cabinet

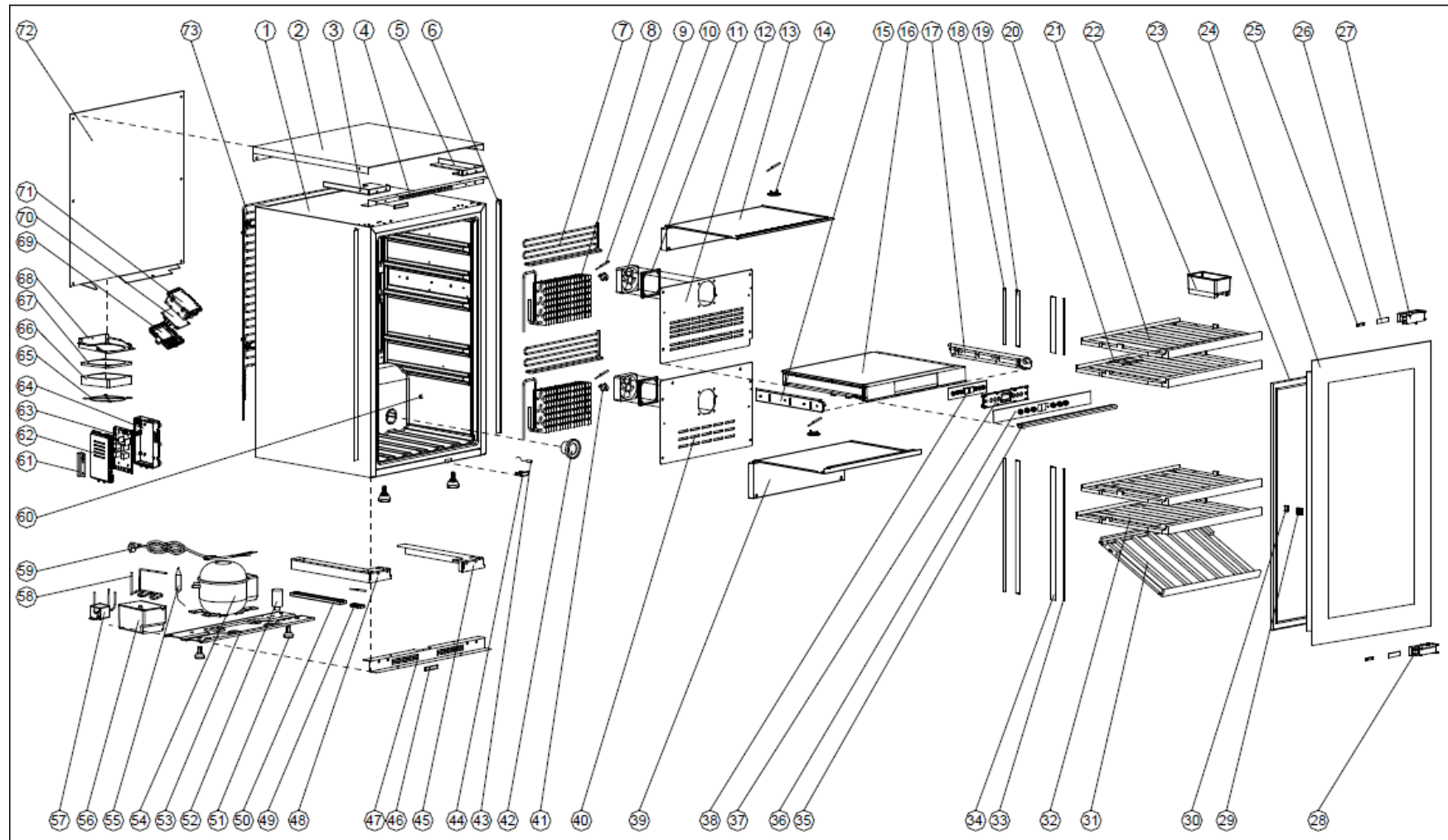



WC6530

Caple Fully Built-in Wine Cabinet

Item	Part Number	Description	Quantity
1.	901.128-207901	Cabinet	1
2.	1.128.200017	Top Cover	1
3.	1.158.200006	Left Top Hinge Plate	1
4.	1.128.200061	Top Fixing Strip	1
5.	1.158.200007	Right Top Hinge Plate	1
6.	2.128.230002	Side Gasket	2
7.	3.145.250001	Heater	2
8.	4.090.200004	Evaporator Assembly	2
9.	3.000.010019	Defrost Thermostat	5
10.	3.000.000064	Fan Motor 8025LS	2
11.	2.000.000117	Fan Gasket 80	2
12.	2.128.220003	Top Air Channel Cover	1
13.	1.078.200100	Top Air Distributor	1
14.	2.000.000178	Thermostat Cover	2
15.	2.145.210012	Left Guider	1
16.	927.198-204927	Middle Divider	1
17.	2.145.210013	Right Guider	1
18.	3.000.000863	Strip LED Light	2
19.	2.128.200048	Strip LED Light Cover	2
20.	8.128.200019	Full Shelf	1
21.	8.078.200016	Top Shelf	2
22.	2.000.000025	Humidity Box	1
23.	2.128.200008	Door Gasket	1
24.	903.128-208903	Glass Door	1
25.	916.000-100004	Magnetic Activator	2
26.	2.000.000102	Hinge Cover	2
27.	1.000.000064	Top Articulated Hinge (K08)	1
28.	1.000.000065	Bottom Articulated Hinge (K08)	1
29.	2.145.210016	Cushion Base	1
30.	2.000.000090	Silicon Cushion	1
31.	8.128.220019	Display Shelf	1
32.	8.078.200015	Full Shelf	1
33.	3.000.000862	Strip LED Light	2
34.	2.128.200049	Strip LED Light Cover	2
35.	2.090.200011	Isolation Strip	1
36.	5.078.226001	Control Panel Film	1
37.	2.145.200052	PCB Supporter Base	1
38.	3.000.531110	Control PCB (X)	1
39.	1.128.200055	Air Distributor	1



WC6530

Caple Fully Built-in Wine Cabinet

Item	Part Number	Description	Quantity
40.	2.128.220004	Lower Air Channel Cover	1
41.	2.000.000122	Sensor Bracket	2
42.	2.000.000013	Active Charcoal Filter	1
43.	3.000.000116	Reed Switch	1
44.	2.000.000189	Switch Holder	1
45.	1.158.200008	Right Bottom Hinge Plate	1
46.	2.000.000103	Decoration Cover	2
47.	1.128.200062	Bottom Fixing Strip	1
48.	1.158.200009	Left Bottom Hinge Plate	1
49.	2.000.000021	Thermostat Supporter	1
50.	1.150.200062	Wires Cover	1
51.	2.000.000099	Adjustable Leg	4
52.	3.000.000012	EMI Filter	1
53.	1.065.100012	Compressor Base	1
54.	4.145.280005	Compressor	1
	4.145.280005-1	Inverter Controller	1
55.	4.120.200008	Filter Dryer	1
56.	2.000.000016	Water Drip Tray	1
57.	3.000.000052	Solenoid Valve	1
58.	4.000.000016	Evaporating Pipe	1
59.	3.000.000046	Power Supply Cord with BS Plug	1
60.	2.000.000010	Plastic Post	10
61.	1.000.100124	Clip Bracket	1
62.	2.000.100042	Electrical Box Cover (P)	1
63.	3.000.300099	Power PCB (X)	1
64.	2.000.100041	Electrical Box Base (P)	1
65.	1.000.000093	Fan Guard 120	1
66.	3.000.000115	Fan Motor 12025LB	1
67.	2.000.000116	Fan Gasket 120	1
68.	1.128.200016	Fan Bracket	1
69.	2.000.000082	Electrical Box Cover (S)	1
70.	3.000.200038	Control PCB (P)	1
71.	2.000.000083	Electrical Box Base (S)	1
72.	1.128.210006	Condenser Cover	1
73.	4.150.200002	Condenser	1



WC6130 & WC6530

Caple Fully Built-in Wine Cabinet

Systems & Component Access/Changes



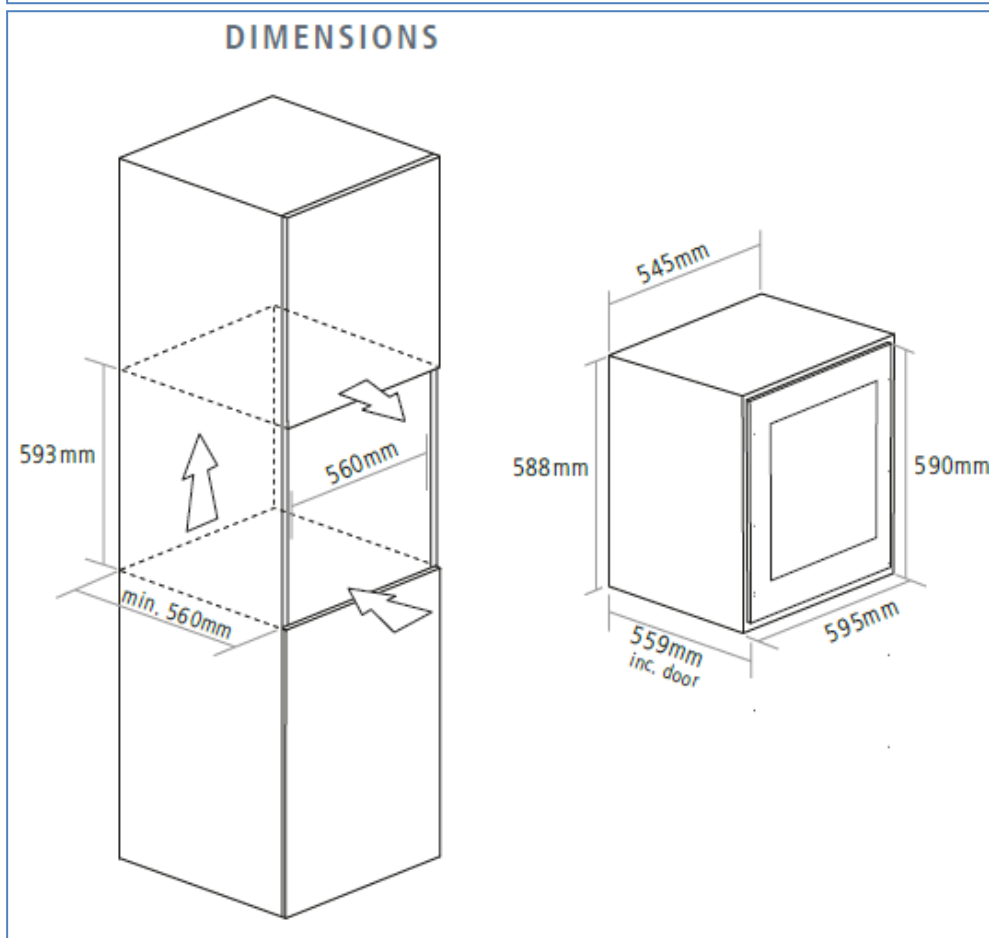
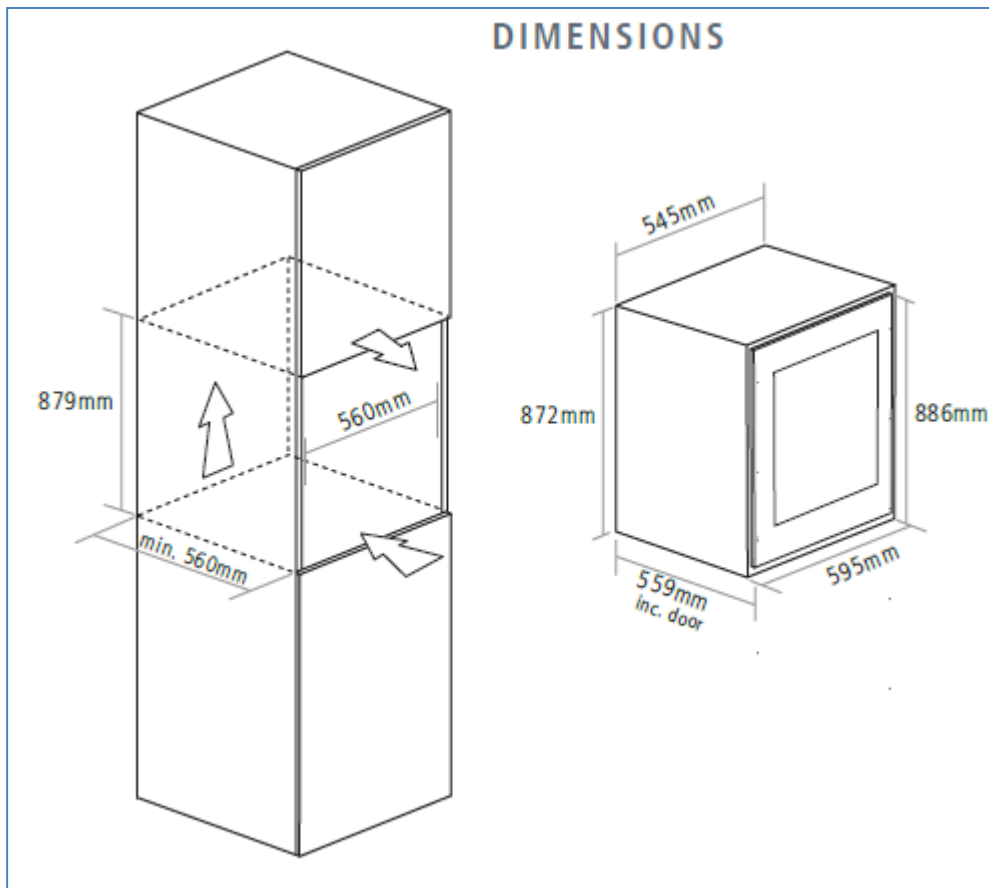

EFFICIENT VENTILATION:

Enjoy hassle-free installation with the self-ventilating feature of the WC6530 and WC6130 wine cooler, eliminating the need for a plinth grille as air is efficiently drawn beneath the appliance and expelled above the door back into the room.

⚡ WARNING ⚡

- Before servicing, make sure to disconnect the power supply.
- Replace all parts before operating the appliance after service.
- Failure to do so could result in death, electrical shock or personal injury.
- All servicing must be carried out by the qualified technicians. Repairs undertaken incorrectly may cause the considerable risk to the user.
- For the units with R600a as the coolant please make sure to release all of refrigerant before servicing the cooling system otherwise fires or explosion will be resulted.
- Personal Injury Hazard - To prevent unnecessary risk of fire, electrical shock or personal injury, all wiring and grounding must be done in accordance with National Electrical Code and local codes and ordinances.

SAFETY PRECAUTIONS

NOTE: Servicing shall be performed only as recommended by the manufacturer.

Please read the following instructions before servicing your products.

1. Check if an electric leakage occurs in the unit.
2. Disconnect the power supply prior to servicing to prevent electric shock.
3. Whenever testing with power on, wear rubber gloves to prevent electric shock.
4. If you use any kind of appliance, check regular current, voltage and capacity.
5. Don't touch the evaporator with wet hands. This may cause frostbite.
6. Prevent water from following onto electric elements in the mechanical parts.
7. When you stand up during observing the lower part with the upper door open, move with care to prevent head wound which may happen by hitting the upper door.
8. When tilting the unit, remove any materials in the unit.
9. When servicing the evaporator, wear cotton gloves. This is to prevent injuries from the sharp evaporator fins.
10. Leave the disassembly of the refrigerating cycle to a specialized service center. The gas inside the circuit may pollute the environment.
11. When you discharge the refrigerant, wear the protective safety glasses or goggle for eye safety.
12. When you repair the refrigerating cycle system, the work area is well ventilated. Especially if the refrigerant is R600a, there are no fire or heat sources. (No smoking)

SERVICING

Qualification of Servicers

Every working procedure such as service and repair operations that affects safety means shall only be carried out by competent persons achieved competence and documented by a certificate.

Examples for such working procedures are

- a) breaking into the refrigerating circuit;
- b) opening of sealed components;
- c) opening of ventilated enclosures.

Checks to the area

Prior to beginning work on systems containing FLAMMABLE REFRIGERANTS, safety checks are necessary to ensure that the risk of ignition is minimised.

Work procedure

Work shall be undertaken under a controlled procedure so as to minimise the risk of a flammable

gas or vapour being present while the work is being performed.

General work area

All maintenance staff and others working in the local area shall be instructed on the nature of work being carried out. Work in confined spaces shall be avoided.

Checking for presence of refrigerant

The area shall be checked with an appropriate refrigerant detector prior to and during work, to ensure the technician is aware of potentially toxic or flammable atmospheres. Ensure that the leak detection equipment being used is suitable for use with all applicable refrigerants, i.e., nonsparking, adequately sealed, or intrinsically safe.

Presence of fire extinguisher

If any hot work is to be conducted on the refrigerating equipment or any associated parts, appropriate fire extinguishing equipment shall be available on hand. A dry chemical or CO₂ fire extinguisher should be adjacent to the charging area.

No ignition sources

No person carrying out work in relation to a REFRIGERATING SYSTEM which involves exposing any pipe work shall use any sources of ignition in such a manner that it may lead to the risk of fire or explosion. All possible ignition sources, including cigarette smoking, should be kept sufficiently far away from the site of installation, repairing, removing and disposal, during which refrigerant can possibly be released to the surrounding space. Prior to work taking place, the area around the equipment shall be surveyed to make sure that there are no flammable hazards or ignition risks. "No Smoking" signs shall be displayed.

Ventilated area

Ensure that the area is in the open or that it is adequately ventilated before breaking into the system or conducting any hot work. A degree of ventilation shall continue during the period that the work is carried out. The ventilation should safely disperse any released refrigerant and preferably expel it externally into the atmosphere.

Checks to the refrigerating equipment

Where electrical components are being changed, they shall be fit for the purpose and to the correct specification. At all times, the manufacturer's maintenance and service guidelines shall be followed. If in doubt, consult the manufacturer's technical department for assistance.

The following checks shall be applied to installations using FLAMMABLE REFRIGERANTS:

- a) the actual REFRIGERANT CHARGE is in accordance with the room size within which the refrigerant containing parts are installed;
- b) the ventilation machinery and outlets are operating adequately and are not obstructed;
- c) if an indirect refrigerating circuit is being used, the secondary circuit shall be checked for the presence of refrigerant;
- d) marking to the equipment continues to be visible and legible. Markings and signs that are illegible shall be corrected;
- e) refrigerating pipe or components are installed in a position where they are unlikely to be exposed to any substance which may corrode refrigerant containing components, unless the components are constructed of materials which are inherently resistant to being corroded or are suitably protected against being so corroded.

Checks to electrical devices

Repair and maintenance to electrical components shall include initial safety checks and component inspection procedures. If a fault exists that could compromise safety, then no electrical supply shall be connected to the circuit until it is satisfactorily dealt with. If the fault cannot be corrected immediately but it is necessary to continue operation, an adequate temporary solution shall be used. This shall be reported to the owner of the equipment, so all parties are advised.

Initial safety checks shall include:

- a) that capacitors are discharged: this shall be done in a safe manner to avoid possibility of sparking;
- b) that no live electrical components and wiring are exposed while charging, recovering or purging the system;
- c) that there is continuity of earth bonding.

Repairs to sealed components

During repairs to sealed components, all electrical supplies shall be disconnected from the equipment being worked upon prior to any removal of sealed covers, etc. If it is absolutely necessary to have an electrical supply to equipment during servicing, then a permanently operating form of leak detection shall be located at the most critical point to warn of a potentially hazardous situation.

Particular attention shall be paid to the following to ensure that by working on electrical components, the casing is not altered in such a way that the level of protection is affected. This shall include damage to cables, excessive number of connections, terminals not made to original specification, damage to seals, incorrect fitting of glands, etc.

Ensure that the apparatus is mounted securely.

Ensure that seals or sealing materials have not degraded to the point that they no longer serve the purpose of preventing the ingress of flammable atmospheres. Replacement parts shall be in accordance with the manufacturer's specifications.

Repair to intrinsically safe components

Do not apply any permanent inductive or capacitance loads to the circuit without ensuring that this will not exceed the permissible voltage and current permitted for the equipment in use.

Intrinsically safe components are the only types that can be worked on while live in the presence of a flammable atmosphere. The test apparatus shall be at the correct rating.

Replace components only with parts specified by the manufacturer. Other parts can result in the ignition of refrigerant in the atmosphere from a leak.

Cabling

Check that cabling will not be subject to wear, corrosion, excessive pressure, vibration, sharp edges, or any other adverse environmental effects. The check shall also take into account the effects of aging or continual vibration from sources such as compressors or fans.

Detection of flammable refrigerants

Under no circumstances shall potential sources of ignition be used in the searching for or detection of refrigerant leaks. A halide torch (or any other detector using a naked flame) shall not be used.

The following leak detection methods are deemed acceptable for all refrigerant systems.

Electronic leak detectors may be used to detect refrigerant leaks but, in the case of FLAMMABLE REFRIGERANTS, the sensitivity might not be adequate, or might need recalibration. (Detection equipment shall be calibrated in a refrigerant-free area.) Ensure that the detector is not a potential source of ignition and is suitable for the refrigerant used. Leak detection equipment shall be set at a percentage of the LFL of the refrigerant and shall be calibrated to the refrigerant employed, and the appropriate percentage of gas (25 % maximum) is confirmed.

Leak detection fluids are also suitable for use with most refrigerants but the use of detergents containing chlorine shall be avoided as the chlorine can react with the refrigerant and corrode the copper pipe-work.

If a leak is suspected, all naked flames shall be removed/extinguished.

If a leakage of refrigerant is found which requires brazing, all of the refrigerant shall be recovered from the system. Removal of refrigerant shall be according to instruction of removal and evacuation.

Removal and evacuation

When breaking into the refrigerant circuit to make repairs – or for any other purpose

—conventional procedures shall be used. However, for flammable refrigerants it is important that best practice be followed, since flammability is a consideration. The following procedure shall be adhered to:

- a) safely remove refrigerant following local and national regulations;
- b) purge the circuit with inert gas;
- c) evacuate;
- d) purge with inert gas;
- e) open the circuit by cutting or brazing.

The refrigerant charge shall be recovered into the correct recovery cylinders if venting is not allowed by local and national codes. For appliances containing flammable refrigerants, the system shall be purged with oxygen-free nitrogen to render the appliance safe for flammable refrigerants. This process might need to be repeated several times. Compressed air or oxygen shall not be used for purging refrigerant systems.

For appliances containing flammable refrigerants, refrigerants purging shall be achieved by breaking the vacuum in the system with oxygen-free nitrogen and continuing to fill until the working pressure is achieved, then venting to atmosphere, and finally pulling down to a vacuum. This process shall be repeated until no refrigerant is within the system. When the final oxygen-free nitrogen charge is used, the system shall be vented down to atmospheric pressure to enable work to take place.

Ensure that the outlet for the vacuum pump is not close to any potential ignition sources and that ventilation is available.

Charging procedures

In addition to conventional charging procedures, the following requirements shall be followed.

- a) Ensure that contamination of different refrigerants does not occur when using charging equipment. Hoses or lines shall be as short as possible to minimise the amount of refrigerant contained in them.
- b) Cylinders shall be kept in an appropriate position according to the instructions.
- c) Ensure that the REFRIGERATING SYSTEM is earthed prior to charging the system with refrigerant.
- d) Label the system when charging is complete (if not already).
- e) Extreme care shall be taken not to overfill the REFRIGERATING SYSTEM.

Prior to recharging the system, it shall be pressure-tested with the appropriate purging gas. The system shall be leak-tested on completion of charging but prior to commissioning. A follow up leak test shall be carried out prior to leaving the site.

Decommissioning

Before carrying out this procedure, it is essential that the technician is completely familiar with the equipment and all its detail. It is recommended good practice that all refrigerants are recovered safely. Prior to the task being carried out, an oil and refrigerant sample shall be taken in case analysis is required prior to re-use of recovered refrigerant. It is essential that electrical power is available before the task is commenced.

- a) Become familiar with the equipment and its operation.
- b) Isolate the system electrically.
- c) Before attempting the procedure, ensure that:
 - i) mechanical handling equipment is available, if required, for handling refrigerant cylinders;
 - ii) all personal protective equipment is available and being used correctly;
 - iii) the recovery process is supervised at all times by a competent person;
 - iv) recovery equipment and cylinders conform to the appropriate standards.
- d) Pump down refrigerant system, if possible.
- e) If a vacuum is not possible, make a manifold so that refrigerant can be removed from various parts of the system.
- f) Make sure that cylinder is situated on the scales before recovery takes place.
- g) Start the recovery machine and operate in accordance with instructions.
- h) Do not overfill cylinders (no more than 80 % volume liquid charge).
- i) Do not exceed the maximum working pressure of the cylinder, even temporarily.

j) When the cylinders have been filled correctly and the process completed, make sure that the cylinders and the equipment are removed from site promptly and all isolation valves on the equipment are closed off.

k) Recovered refrigerant shall not be charged into another REFRIGERATING SYSTEM unless it has been cleaned and checked.

Labelling

Equipment shall be labelled stating that it has been de-commissioned and emptied of refrigerant. The label shall be dated and signed. For appliances containing FLAMMABLE REFRIGERANTS, ensure that there are labels on the equipment stating the equipment contains FLAMMABLE REFRIGERANT.

Recovery

When removing refrigerant from a system, either for servicing or decommissioning, it is recommended good practice that all refrigerants are removed safely.

When transferring refrigerant into cylinders, ensure that only appropriate refrigerant recovery cylinders are employed. Ensure that the correct number of cylinders for holding the total system charge is available. All cylinders to be used are designated for the recovered refrigerant and labelled for that refrigerant (i.e., special cylinders for the recovery of refrigerant). Cylinders shall be complete with pressure-relief valve and associated shut-off valves in good working order. Empty recovery cylinders are evacuated and, if possible, cooled before recovery occurs.

The recovery equipment shall be in good working order with a set of instructions concerning the equipment that is at hand and shall be suitable for the recovery of all appropriate refrigerants including, when applicable, FLAMMABLE REFRIGERANTS. In addition, a set of calibrated weighing scales shall be available and in good working order. Hoses shall be complete with leak-free disconnect couplings and in good condition. Before using the recovery machine, check that it is in satisfactory working order, has been properly maintained and that any associated electrical components are sealed to prevent ignition in the event of a refrigerant release. Consult manufacturer if in doubt.

The recovered refrigerant shall be returned to the refrigerant supplier in the correct recovery cylinder, and the relevant waste transfer note arranged. Do not mix refrigerants in recovery units and especially not in cylinders.

If compressors or compressor oils are to be removed, ensure that they have been evacuated to an acceptable level to make certain that FLAMMABLE REFRIGERANT does not remain within the lubricant. The evacuation process shall be carried out prior to returning the compressor to the suppliers. Only electric heating to the compressor body shall be employed to accelerate this process. When oil is drained from a system, it shall be carried out safely.

COMPRESSOR REFRIGERATING SYSTEM

REFRIGERANT CYCLE DIAGRAM

For single zone & three zone models and dual zone models without Solenoid Valve
(Basic Design) – WC6130

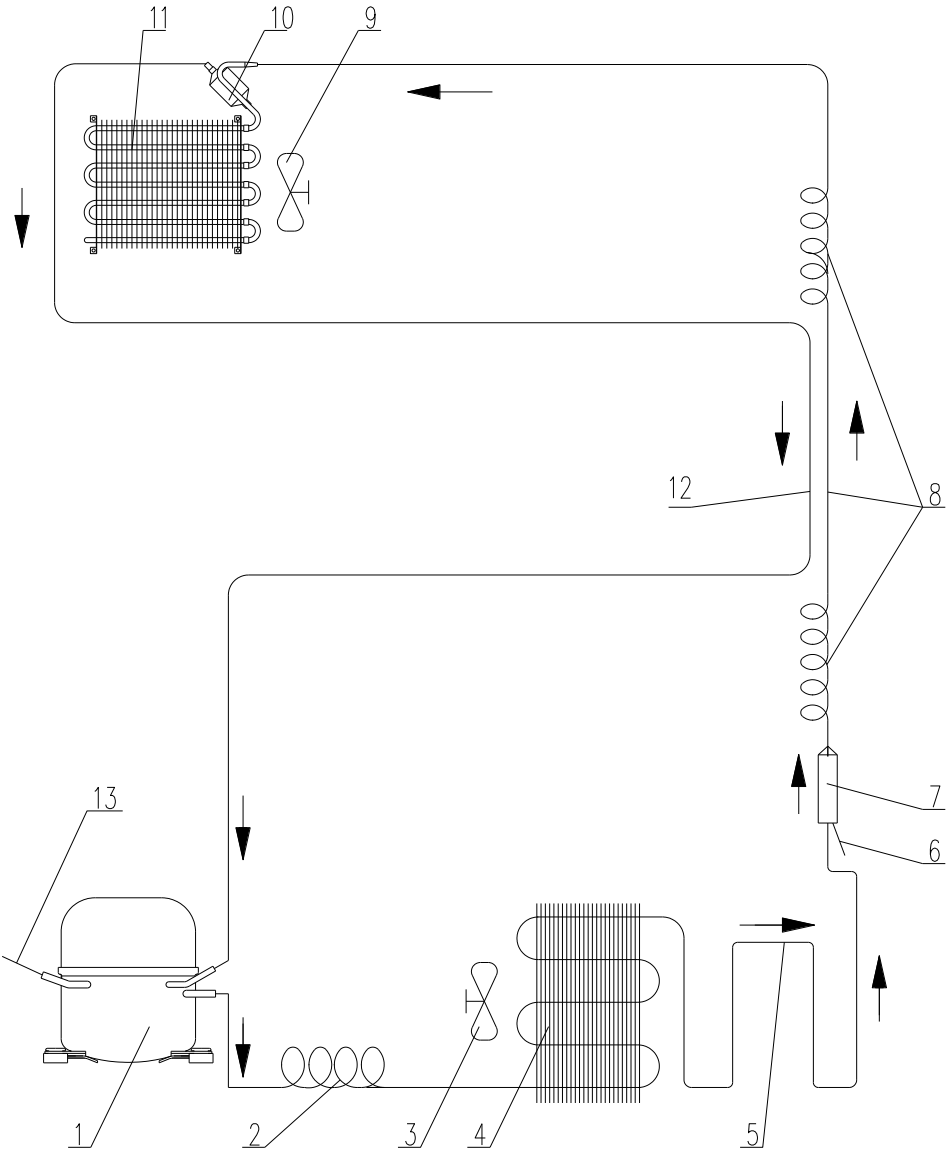

- | | |
|--|-------------------|
| 1. Compressor | 7. Filter Drier |
| 2. Evaporating Pipe | 8. Capillary |
| 3. Condenser Fan (Not available for some models) | 9. Evaporator Fan |
| 4. Condenser | 10. Accumulator |
| 5. Hot Pipe | 11. Evaporator |
| 6. Process Tube | 12. Suction Tube |
| | 13. Process Tube |

Remark: For dual zone wine cabinet, regulate the amount of cold zone air to the warmer zone by controlling the air damper door to make the warmer zone reach the set temperature.

For dual zone models with Solenoid Valve (Twin Wine Conditioning System) – WC6530

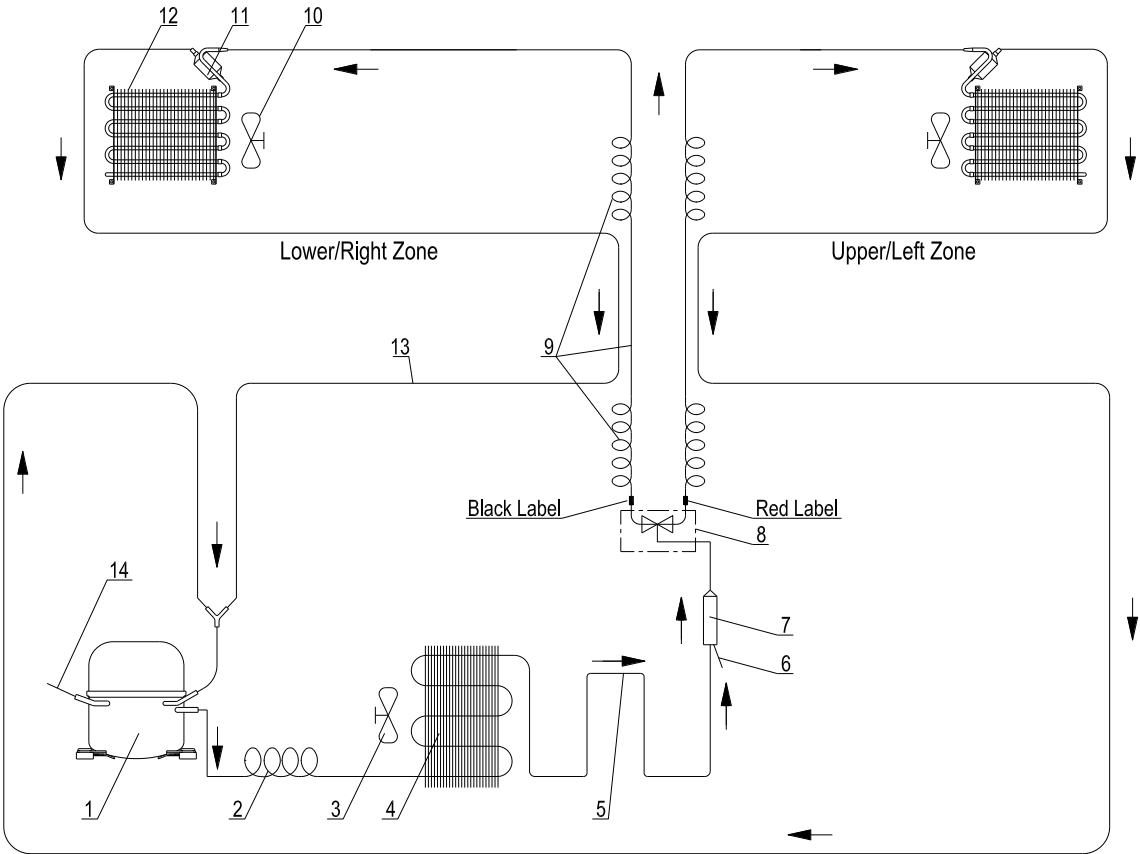

- | | |
|--|---|
| <ul style="list-style-type: none"> 1. Compressor 2. Evaporating Pipe 3. Condenser Fan 4. Condenser 5. Hot Pipe 6. Process Tube 7. Filter Drier | <ul style="list-style-type: none"> 8. Solenoid Valve 9. Capillary 10. Evaporator Fan 11. Accumulator 12. Evaporator 13. Suction Tube 14. Process Tube |
|--|---|

REFRIGERATION SYSTEM

All refrigeration units cool by removing heat from the cabinet rather than pumping in cool air. In a conventional refrigeration unit, liquid refrigerant enters the evaporator and vaporizes (boils) due to the low pressure, creating a very cold surface which removes heat from inside the cabinet. This causes the refrigerant to boil (evaporate) into a vapor state and be drawn into the compressor. The compressor pressurizes the vapor and pumps it into the condenser. The hot vapor in the condenser gives off the heat into the room. As the vapor cools, it condenses back into a liquid and returns to the evaporator to start the process over again. The system continually soaks up the heat inside the refrigerator and deposits the heat back into the room.

- The compressor of the refrigeration system serves two purposes: it ensures movement of the refrigerant throughout the system and it increases the pressure and temperature of the vapor received from the suction line and pumps the refrigerant into the discharge line. The condenser receives this high temperature, high pressure refrigerant and allows the heat to be released into the cooler surroundings. This heat removal "condenses" the refrigerant vapor into a liquid.
- The hot pipe is the first part of the condenser routed around the cabinet to help prevent moisture formation.
- The filter dryer is installed at the end of the condenser to capture moisture which may be present in the system.
- The capillary tube meters the flow of refrigerant and creates a pressure drop. Size and length of the capillary is critical to the efficiency of the system.
- As the refrigerant leaves the capillary tube and enters the larger tubing of the evaporator, the sudden increase in tubing diameter, and the pumping action of the compressor, form a low pressure area. The temperature of the refrigerant drops rapidly as it changes to a mixture of liquid and vapor. In the process of passing through the evaporator, the refrigerant absorbs heat from the storage area and is gradually changed from a liquid and vapor mixture (saturated refrigerant) into a vapor.
- The suction line returns this low pressure vapor from the evaporator back to the compressor, and the cycle starts again.
- Part of the capillary tube is soldered to the suction line which forms a heat exchanger. Heat from the capillary tube is thus transferred to the suction line to superheat the refrigerant there and at the same time this further cools the liquid in the capillary tube. This cools the refrigerant before it enters the evaporator and also heats the refrigerant before it enters the compressor to ensure a vapor state.

REFRIGERATION SYSTEM COMPONENTS

Compressor

The compressor is the "heart" of the refrigeration unit, consisting of an electrical motor and a "pump" sealed inside a steel case. If a new compressor is to be installed, pull one of the plugs to ensure that it is properly pressurized. If no pressure is observed, do not use the compressor. If unit is pressurized, reinstall the plug and keep the compressor sealed until it is installed and ready for solder connections. Whenever the compressor is replaced, the sealed system must be flushed.

Condenser

The condenser is a long folded tube with steel wires which receives the hot, high pressure vapor from the compressor. While the most common problem is keeping the condenser clean from lint and dirt buildup which prevents proper airflow and the required transfer of the heat to the surroundings, it is possible that due to an un-repairable leak or a non-removable restriction, the condenser could require replacement. Do not remove the plugs on the condenser inlet and outlet tubes until the new condenser is mounted in place and made ready for brazing. The inlet side will connect to the hot pipe and the outlet to the filter drier for built-in models and for built-in models the condenser can be replaceable. But for free-standing models the inlet side will connect to the discharge pipe of compressor and the outlet to filter drier, it is non-replaceable.

Evaporator

The evaporator is a fin tube type within the rear side of cabinet and can be replaceable. If a leak is present in the evaporator, it is not repairable and must be replaced. After mounting the evaporator in place, connect the capillary tube to the replacement filter drier.

Filter Drier

Whenever the sealed system is entered, the filter drier must and can be replaced. This filter drier has the proper desiccant suitable for the refrigerant. The filter drier is stamped with an arrow which indicates the direction of refrigerant flow. The drier inlet has two lines -one connects to the condenser and the other will be used as a process tube through which the system sweep and final charge will be made. The drier outlet will be connected to the capillary tube. Care should be taken to ensure that the capillary is not inserted too far into the filter drier to make contact with its internal screen, yet in far enough to prevent restricting the small diameter capillary tube opening with the solder alloy.

Hot Pipe

The hot pipe is a **non-replaceable** component of the sealed system routed within the walls of the cabinet. To diagnose the hot pipe, the tubing must be isolated from the sealed system. If the hot pipe fails to hold the vacuum, the hot pipe is possible to be bypassed by connecting the condenser outlet tube directly to the inlet of filter drier.

Capillary

The capillary tube meters the flow of refrigerant and creates a pressure drop. Size and length of the capillary is critical to the efficiency of the system.

SERVICE PRECAUTIONS FOR R600A SYSTEM

Features of refrigerant (R600a)

- Achromatic and odor less gas.
- Flammable gas and the ignition (explosion) at 494°C.
- Upper/lower explosion limit: 1.8%~8.4%/Vol.

Features of the R600a refrigeration unit

- The suction pressure is below 1bar (abs) during the operation.
- Because of its low suction pressure, the external air may flow in the cycle system when the refrigerant leaks, and it causes malfunction in the compressor.
- Any type of dryer is applicable (XH-5, 7, 9).
- The EVAPORATOR or any other cycle part that has welding joint is hidden in the foam. (If not hidden inside, the whole electric parts must be tested with the LEAKAGE TEST according to the IEC Standard.)
- The compressor has label of the refrigerant R600a.
- Only the SVC man must have an access to the system.

Installation place

- Must be well ventilated.
- Must be 20 m³ or larger.
- Must be no-smoking area.
- No ignitable factors must be present.

Utilities

- Refrigerant cylinder (MAX NET 300g)
- Manometer
- Vacuum pump (600L/min)
- Piercing Clamp
- Quick coupler • Hoses (5m-1EA, 1m-3EA)
- LOKRING
- Portable Leakage detector (3g/year)
- Nitrogen cylinder (for leakage test)
- Concentration gauge

Make sure before Servicing

- Refrigerant Confirm: the refrigerant by checking Name Plate and the label on the compressor, after opening the COVER ASSY, BACK-M/C.
- If the refrigerant is R600a, you must not weld or apply a heat source.

Air Recharging in Compressor

Before refilling the refrigerant, you must perform the test according to "TROUBLESHOOTING GUIDE". When the defects are found, you must discharge the residual refrigerant (R600a) in the outdoor. For discharging the refrigerant R600a, break the narrow portion of tube extension by hand or with a pipe cutter. Leave it for 30min in outside to stabilize the pressure with ambient. Then, check the pressure by piercing the filter dryer part with piercing pliers. If the refrigerant is not completely discharged, let the refrigerator alone for more 30min in outside.

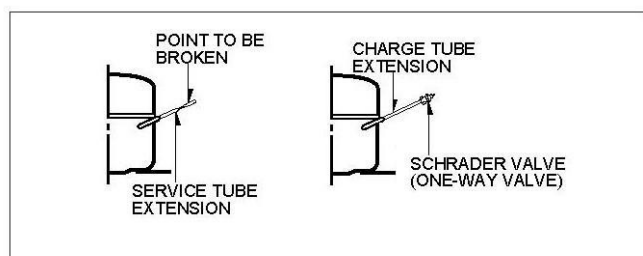

Attach the service tube installed with a

Schrader valve (one-way valve). Then, connect the Schrader valve (one-way valve) to the pump that is connected to the discharging hose leading to the outside. When discharging the residual refrigerant, repeat 3 cycles that includes 3min of the pump running->pump off->30sec of the compressor running.

After the refrigerant (R600a) is completely discharged, repair any defective parts and replace the filter dryer. Connect the Schrader valve to pump with the coupler. And then turn the pump on for vacuum state. Let the pump run until the low-pressure gauge indicates the vacuum (gauge pressure 0, absolute pressure -1atm or -760mmHg). Recommended vacuum time is 30 min. Charge the N2 gas in order to check for leakage from welding points. If leakages are found, repair the defects and repeat the vacuum process.

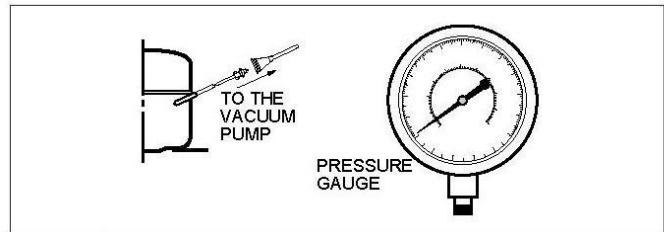

After the system is completely vacuumed, fill it with the refrigerant R600a up to what has been specified at your unit Rating Label. The amount of refrigerant (R600a) must be precisely measured within the error of $\pm 1g$ by an electronic scale.

If you use the manifold connected with both the refrigerant (R600a) cylinder and the vacuum pump simultaneously, make sure the pump valve is closed.

Connect the charging hose (that is connected to the refrigerant (R600a) cylinder) to the Schrader valve installed on the service tube. Then, charge the refrigerant (R600a) by controlling the Throttle valve. When you do so, do not fully open the Throttle valve because it may make damage to the compressor. Gradually charge the refrigerant (R600a) by changing open and close the Throttle Valve (5g at each time). The charging hose must use a one-way valve to prevent the refrigerant reflux. Close the Schrader valve cap after the refrigerant (R600a) is completely recharged.

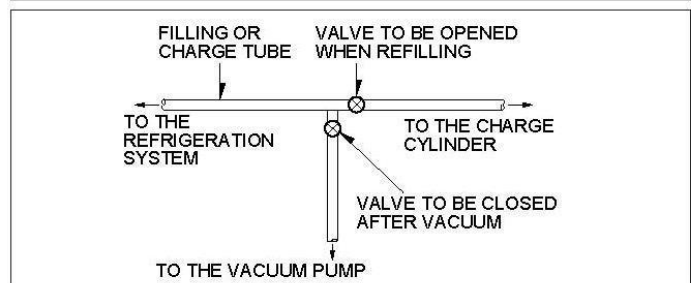
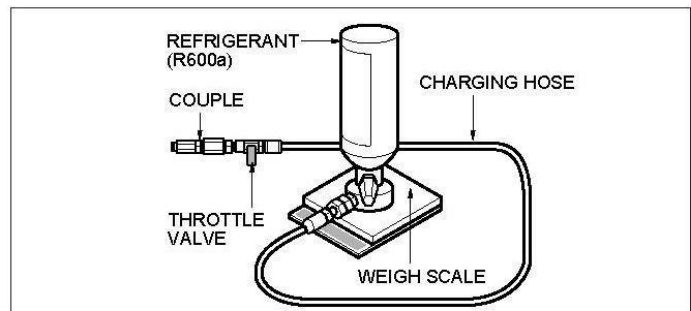

After you completely recharge the refrigerant (R600a), perform the leakage test by using a portable leakage detector or soapy water. Test the low pressure (suction) parts in compressor off time and high pressure parts in compressor on time. If the leakages are found, restart from the refrigerant (R600a) discharging process and repairs defects of leaks.

After the leakage test, check the temperature of each parts of the cycle. Check with hands if the CONDENSER and the case (Hot Pipe) that is contacted to the door gasket are warm. Confirm that frost is uniform distributed on the surface of the EVAPORATOR.

COMPRESSOR ROOM VIEW AND PARTS LIST

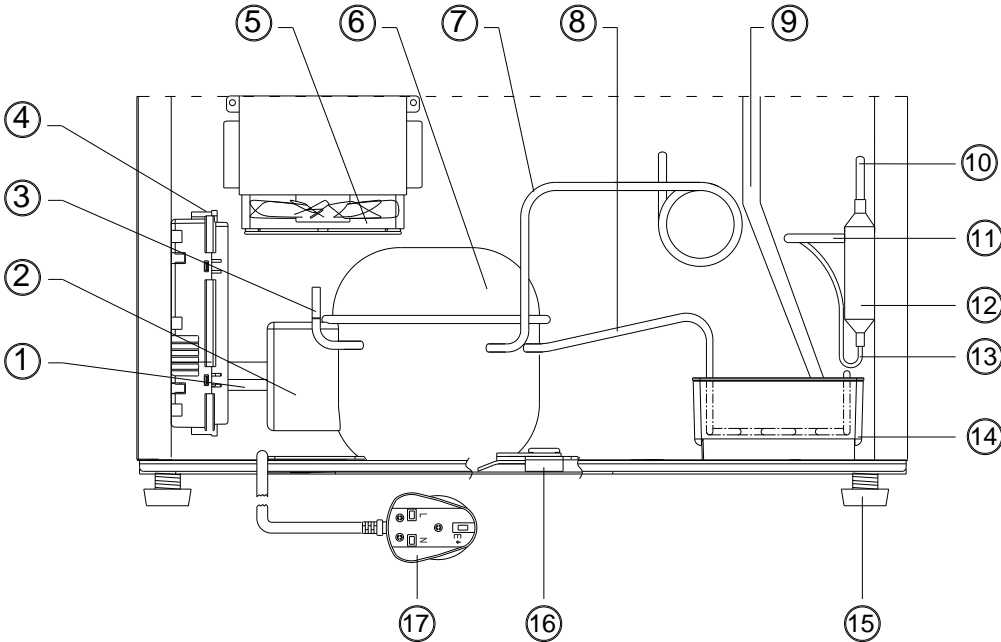

1. Joint of condenser outlet tubing and hot pipe inlet tubing
2. Electrical Box of Compressor
3. Process Pipe
4. Electrical Box (Power PCB inside)
5. Condenser Fan Motor
6. Compressor
7. Suction Pipe
8. Discharge Pipe
9. Drainage Hose
10. Outlet Tubing of Hot Pipe
11. Process Pipe
12. Filter Drier
13. Capillary
14. Water Drip Tray
15. Leveling Leg
16. Compressor Leg
17. Power Supply Cord with Plug

ELECTRICAL AND CONTROL SYSTEM

CONTROL DESCRIPTION

FUNCTIONS

Cooling mode:

When the set temperature is lower than the storage temperature, the unit operates in cooling mode with compressor ON.

Heating mode:

When the set temperature is higher than the storage temperature, the unit operates in heating mode with heater ON.

Eco mode:

In the Eco mode, the interior fan cycles on and off to circulate the inside air evenly even the set temperature is reached. Eco mode is **NOT** the factory preset mode because of creating noises and more energy consumption. In the SILENT mode (Also known as energy saving mode), the appliance will run without the fan once the set temperature is reached. This Eco mode enables the relative humidity inside the unit and the temperature to be distributed evenly around the interior so you can store all your wine under exactly the same excellent conditions. If you would like to use the unit to store wine long term, the Eco mode is a must. This will create a continuous climate in the cabinet which imitates that of a wine cabinet.

Demo mode:

Demo mode can be activated by presenting the appliance at exhibitions or in salesrooms. In Demo mode, the compressor and all fan motors are switched OFF.

By pressing and holding the “**UP**”&“**DOWN**” (The controls of upper/left zone for dual zone LED display models) and “**LIGHT**” keys at the same time for at least 5 seconds, the indicator light will flash five times to confirm the input and the unit will operate in Eco Demo mode. The indicators for Fahrenheit and Celsius degree will be ON. Eco Demo mode can be canceled by repeating the above process.

NOTE: To perform the multi-key function, press and hold the first key, then press the rest key the required number of times and then release all the keys.

SABBATH Mode:

Sabbath mode is available for the observance of certain religious holidays. This mode turns off the displays, interior light and audible alarms and prevents them from turning on again. Normal cooling operations will still take place.

To initiate Sabbath mode, press the **POWER** and **LIGHT** keys at the same time for at least 5 seconds. The displays and interior lights will go out to confirm the Sabbath mode is ON. Sabbath mode can be canceled by repeating the above process. The Sabbath Mode will automatically turn off after 48 or 96 hours.

ALARM SYSTEM

Temperature Display

During normal operation, the temperature displays on the control panel show the temperatures inside the appliance. The temperature display will flash if

- A different temperature is being set,
- The temperature in one of the zones deviates by more than 5°C from the set temperature.

The temperature display flashing ensures that the temperature can't rise or fall un-noticed and impair the wine.

To view the “set” temperature at any time, touch the “**UP**” or “**DOWN**” mark, the “set” temperature will temporarily flash in the LED display for 5 seconds for LED display models. For LCD display models, touch the **Setting Selector** key, the set temperature will temporarily flash in the display for 5 seconds.

If the LED readouts display the icon “--” and flash, that means the display temperature is out of the range from -9 to 37°C for Celsius degree and from 16 to 99°F for Fahrenheit degree. That is normal.

Temperature Alarm

An alarm will sound if the temperature in one of the zones rises or falls outside the temperature range. The relevant temperature display will flash at the same time.

The temperature the appliance is set at determines the temperature the appliance recognizes as being too warm or too cool.

The alarm will sound and the temperature display will flash:

- When you switch the appliance on, if the temperature inside the appliance is very different from the temperature set.
- When there has been a lengthy interruption to the power supply.
- When too many items have been put into the unit at one time.
- When the door is not been closed tightly.

Door Alarm

If the door has been left open for more than 60 seconds, the alarm will sound.

Once the set temperature has been reached in the appliance, the alarm stops and the relevant temperature display stops flashing. However, if the noise disturbs you, you can switch the alarm off before this if you wish by pressing any key once. The alarm will stop. The relevant temperature display continues to flash until the set temperature has been reached. The display then lights up constantly, and the alarm system is fully active again.

OTHER FUNCTIONS

Temperature Memory Function

In the event of a power interruption (power surge, breaker switch, etc.), the unit can remember the previous temperature settings, and when the power is recovery, the unit will operate with the last temperature set-point and the cabinet temperature will go back the same setting temperature as power off.

Interior Light

The interior light makes it easy to view your wine labels and enhances the display of your collection. Touching and hold the LIGHT mark for 5 seconds toggles between 2 modes of operation for the internal lights: functional (default) mode and showcase mode. If you are in functional (default) mode, the lights will turn on only when the door is open. If you are in showcase mode, the lights will be on whether or not the door is open.

Defrosting

1. The defrosting is performed each time when the total running time of the compressor reaches 10 hours.
2. During the defrosting cycle, the compressor is OFF and the fans and/or the defrost heater will operate continuously.
3. After 30 minutes, the defrosting cycle will end.
4. **During the defrosting cycle, the storage temperature may vary by 3 or 4 degrees. That is normal.**
5. **However, the frost may be accumulated on the evaporator if the unit is repeatedly opened in a high heat or high humidity location. If this frost pattern does not clear within 24 hours, your unit will require manual defrosting.**

Child Lock (Key Lock)

Key Lock function is only available for models with outside control. If in 2 minutes or longer without pressing any key, the key lock will be activated automatically. To remove the lock, press the **UP** and **DOWN** keys at the same time for at least 5 seconds and the indicator light will flash three times to confirm the input.

SETTINGS MODE

Certain settings on the wine cabinet can only be selected in Settings mode. In Settings mode only the **UP** and **DOWN** keys of lower/right zone are functional for dual zone LED display units.

Touch and hold the **UP** key for 5 seconds to enter and leave Settings mode. The appliance will leave Settings mode automatically after approximately one minute.

°F/°C Selection

1. Lightly touch and hold the **UP** key for 5 seconds to enter Settings mode.
2. Use the **UP** and **DOWN** keys to select the temperature display setting in Fahrenheit or Celsius degree.
3. Touch and hold the **UP** key for 5 seconds to confirm the selection.

Display Brightness

1. Lightly touch and hold the **UP** key for 5 seconds to enter Settings mode and then touch the **POWER** key once.
2. Use the **UP** and **DOWN** keys to select the brightness of the display when the door is close. When the door is open, the display brightness returns to its normal level.
d0: off
d1: dimmest setting (default)
d2: medium setting
d3: brightest setting
3. Touch and hold the **UP** key for 5 seconds to confirm the selection.

Interior Lighting Brightness

1. Lightly touch and hold the **UP** key for 5 seconds to enter Settings mode and then touch the **POWER** key twice.
2. Use the **UP** and **DOWN** keys to select the brightness of the interior lighting when the door is close. When the door is open, the interior lighting returns to its normal level.
L0: off when the door is close or open
L1: dimmest setting
L2: medium setting
L3: brightest setting (default)
3. Touch and hold the **UP** key for 5 seconds to confirm the selection.

Fan Mode

1. Lightly touch and hold the **UP** key for 5 seconds to enter Settings mode and then touch the **POWER** key three (3) times.
2. Use the **UP** and **DOWN** keys to select the fan mode.
F0: Silent mode - Energy saving mode (default)
F1: DynaClima mode - half time
F2: DynaClima mode - full time
3. Touch and hold the **UP** key for 5 seconds to confirm the selection.

Audible Tones

1. Lightly touch and hold the **UP** key for 5 seconds to enter Settings mode and then touch the **POWER** key four (4) times.
2. Use the **UP** and **DOWN** keys to select the audible tones.
S0: sensor tone ON, alarm tone OFF
S1: sensor tone ON, alarm tone ON (default)
S2: sensor tone OFF, alarm tone OFF
S3: sensor tone OFF, alarm tone ON

Touch and hold the **UP** key for 5 seconds to confirm the selection.

ELECTRICAL OPERATION SCHEMATIC

Dual Zone - Basic Design (w/o Solenoid Valve) – WC6130

	COMPRESSOR	F0	F1C/F1H	F2C	F2H	HEATER 1	HEATER 2
COOLING @ TOP t1>T1+2	ON	ON	ON	---	---	---	---
HEATING @ TOP t1<T1-2	OFF	OFF	---	ON	---	ON	---
COOLING @ BOTTOM t2>T2+2	---	---	---	ON	---	---	OFF
HEATING @ BOTTOM t2<T2-2	---	---	---	---	ON	---	ON
DOOR OPEN DS=1	---	---	OFF	OFF	OFF	---	---

1) Eco mode - F1C/F1H cycles ON and OFF when No Cooling/Heating @ Top.
2) Silent mode - F1C/F1H is OFF when No Cooling/Heating @ Top.

Dual Zone – Twin Wine Conditioning System (w/ Solenoid Valve in RENESAS IC) – WC6530

	COMPRESSOR	F0	F1C/F1H	F2C	F2H	HEATER 1	HEATER 2
COOLING @ TOP t1>T1+2	ON	ON	ON	---	OFF	OFF	OFF
HEATING @ TOP t1<T1-2	OFF	OFF	ON	---	OFF	ON	OFF
COOLING @ BOTTOM t2>T2+2	ON	ON	---	ON	ON	OFF	OFF
HEATING @ BOTTOM t2<T2-2	OFF	OFF	---	ON	OFF	OFF	ON
DOOR OPEN DS=1	---	---	OFF	OFF	OFF	---	---

1) DynaClima mode - F1C/F1H cycles ON and OFF when No Cooling/Heating @ Top. F2C cycles ON and OFF when No Cooling/Heating@Bottom.
2) Silent mode - F1C/F1H is OFF when No Cooling/Heating @ Top. F2C is OFF when No Cooling/Heating@Bottom.

Fan F1C & F1H:

- For single zone models, F1C & F1H are the evaporator fan motors positioned in the cabinet inside. For dual zone models, F1C & F1H are the fan motors positioned in the upper zone. For three zone models, F1C & F1H are the fan motors positioned in the middle zone.
- For single zone models with heating function, Fan 1C & F1H will operate when the heater is ON and when the compressor is ON.
- For dual zone, when the set temperature of upper zone is lower than the storage temperature, Fan 1C & F1H will operate. At the rest time Fan F1C & F1H will cycle on and

off to circulate air inside the cabinet.

- For three zone, when the set temperature of middle zone is lower than the storage temperature, Fan 1C & F1H will operate. At the rest time Fan F1C & F1H will cycle on and off to circulate air inside the cabinet.

Fan F2C:

- Only available in the models of dual zone or three zone. For dual zone model, F2C is the fan motor positioned in the middle divider. For three zone models, F2C is the fan motor positioned in the bottom divider.
- When the set temperature of the lower zone is lower than the storage temperature, Fan F2C will operate.
- When the set temperature of upper zone for dual zone or middle zone for three zone is higher than the storage temperature, Fan F2C will operate.
- At the rest time Fan F2C will be OFF.

Fan F2H:

- Only available in the models of dual zone or three zone. Fan F2H is the fan motor positioned in the bottom zone.
- When the set temperature of lower zone is higher than the storage temperature, Fan F2H will operate. At the rest time Fan F2H will cycle on and off to circulate air inside the cabinet.

Fan F3C/F3H:

- Only available in the models of three zone. Fan F3C/F3H is the fan motor positioned in the top zone.
- When the set temperature of the top zone is lower than the storage temperature, Fan F3C/F3H will operate.
- When the set temperature of the top zone is higher than the storage temperature, Fan F3H will operate.
- At the rest time Fan F3C/F3H will OFF.

Fan F0:

- Only available in built-in models. When the compressor is ON, Fan F0 will be ON. At the rest time Fan F0 will be OFF.

SELF-CHECK OF CONTROL SYSTEM

The Display/Control PCB has the self-check function. Press and hold the “**LIGHT**” and “**UP**” keys (only the **UP** key of lower/right zone is functional for dual zone LED display units) at the same time for 5 seconds, the unit will activate the self-check program. Below symptoms can be seen, otherwise replace the PCBs:

- LED indicators will be ON one by one.
- LED light will be ON.
- Temperature reader LED will display from 00 to 99.
- Fan motor, compressor and heater will be ON.

After the self-check program has been finished the unit will automatically go into the normal operation program.

TEST MODE – COOLING/HEATING

Press and hold the “**LIGHT**” and “**DOWN**” keys (only the **DOWN** key of upper zone is functional for dual zone LED display models with non-twin wine conditioning) at the same time for 5 seconds with power ON, the unit will run in the TEST MODE - COOLING. The compressor and all fan motors will operate continuously & independent from the SET temperature. At the same time the display shows the icon “--”. The TEST Mode will automatically turn off after 10 minutes or you can stop the TEST mode by disconnect the unit from power source.

For the LED display models with twin wine conditioning system, pressing and holding the “**LIGHT**” and “**DOWN**” of upper/left zone keys at the same time for 5 seconds with power ON can activate the upper/left zone to run in TEST MODE - COOLING. pressing and holding the “**LIGHT**” and “**DOWN**” of lower/right zone keys at the same time for 5 seconds with power ON can activate the lower/right zone to run in TEST MODE - COOLING.

SENSOR RESISTANCE CHARACTERISTICS TABLE

No.	MEASURED TEMPERATURE (°C)	RESISTANCE OF SENSOR (kΩ)
1	-30	116.55
2	-28	104.97
3	-26	94.67
4	-24	85.49
5	-22	77.30
6	-20	69.99
7	-18	63.44
8	-16	57.58
9	-14	53.32
10	-12	47.60
11	-10	43.35
12	-8	39.53
13	-6	36.08
14	-4	32.97
15	-2	30.16
16	0	27.62
17	2	25.32
18	4	23.24
19	6	21.35
20	8	19.63
21	10	18.07
22	12	16.65
23	14	15.35
24	16	14.17
25	18	13.10
26	20	12.11
27	22	11.21
28	24	10.39
29	25	10.00
30	26	9.63
31	28	8.94
32	30	8.30
33	32	7.72
34	34	7.18
35	36	6.69
36	38	6.23
37	40	5.81
38	42	5.42
39	44	5.06
40	46	4.73
41	48	4.43
42	50	4.15

- The tolerance of sensor resistance is $\pm 5\%$
- Be sure to measure the sensor resistance after keeping the sensor more than 3 minutes at a measuring temperature. (It needs delay due to sensor speed.)

HOW TO REVERSE THE DOOR SWING

This wine cabinet has the capability of the door opening from either the left or right side. The unit is delivered to you with the door opening from the left side. Should you desire to reverse the opening direction, please follow the following reversal instructions:

Note: All parts removed must be saved to do the reinstallation of door.

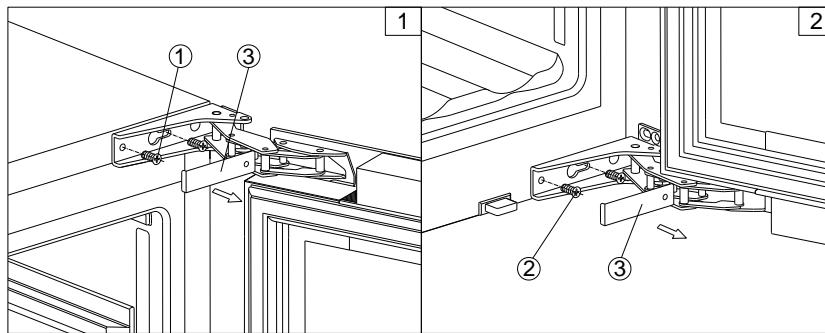

⚠ WARNING

Use extreme caution with the articulated hinges. The hinge is self-closing and many pinch points exist prior to built-in installation.

1. Remove the cover cap (3) and then remove the glass door by unscrewing the four screws (1) and (2). Be careful to hold the glass door firmly after removing the screws and place it on a padded surface to avoid the risk of damage.
2. Pop out the cover caps on the left side of cabinet and use them to cover the screw holes on the right hand side.
3. Rotate the glass door 180° and refit the glass door to the opposite side. Then screw and tighten it after the door is leveled.

HOW TO REPLACE THE MAIN PARTS

REPLACING THE CONTROL PCB IN THE MIDDLE DIVIDER AND REMOVING THE MIDDLE DIVIDER

1. Open the door and softly remove the control panel film ①.
2. Release the latch and then take out the Control PCB ③ and its supporter ② together.
3. Disconnect the cable from the control PCB ③. And now pull the Control PCB out and replace it.
4. Remove all shelves.
5. Remove the four screws ⑦ that connect the bottom air distributor ⑤ to the cabinet and middle divider.
6. Use a flat blade screwdriver ⑥ to release the two latches ④ at the bottom side of middle divider and then you can pull out the whole middle divider.
7. For models with fan motor F2C and air door assembly inside the middle divider, before pulling out the whole middle divider, disconnect the cables to the fan motor and air door

assembly.

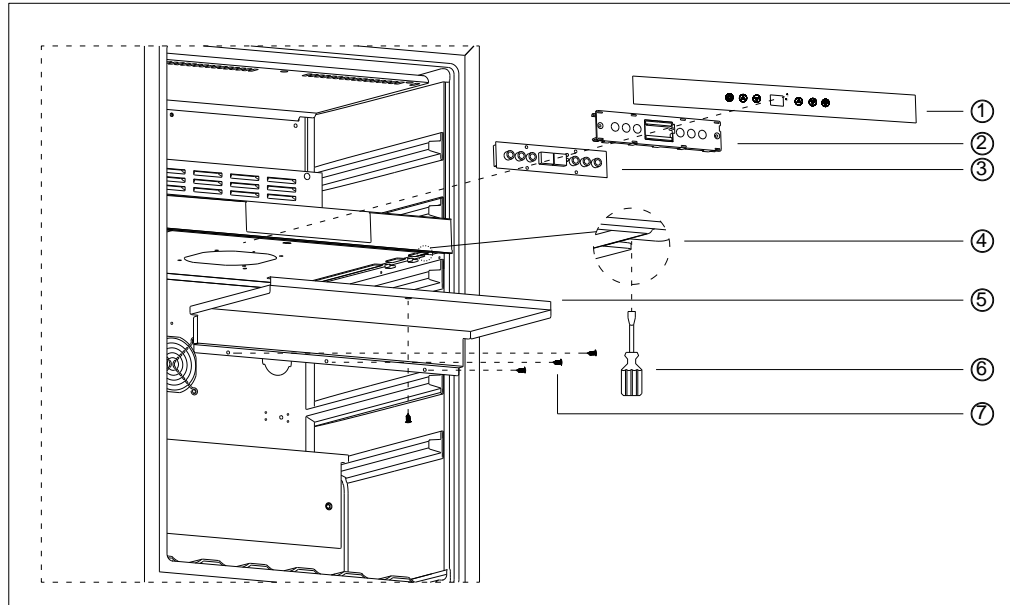

REPLACING THE FAN MOTOR, AIR DOOR ASSEMBLY AND LED LIGHT IN THE MIDDLE DIVIDER

1. Remove the middle divider as clause 7.2.
2. Remove the two screws ① that connect the top plate ③ and two side plastic brackets ⑤ ⑬ of middle divider.
3. Remove the plastic connector ② that connect the bottom plate ⑧ and top plate ③ of middle divider.
4. Disassemble the middle divider.
5. Dismantle the four silicon pins ⑨ that fix the fan motor F2C to the bottom plate of middle divider. Now you can replace the fan motor F2C.
6. Remove the screws ⑩ that fix the air damper ⑫ to the bottom plate of middle divider and now you can replace the air damper.

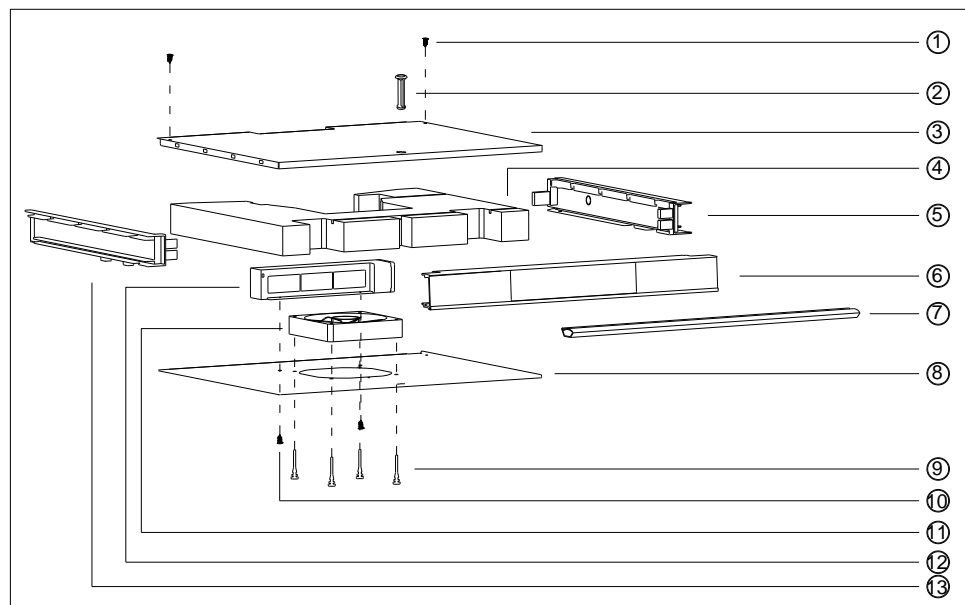

REPLACING THE POWER PCB

1. Remove the eight screws ① that fix the rear grille ② to the cabinet.
2. Remove the screw ④.
3. Pull out the electrical box base ③ & electrical box cover ⑥ and Power PCB ⑤.
4. Remove the screws ⑦.
5. Disconnect the cables from the Power PCB and then you can replace the Power PCB.

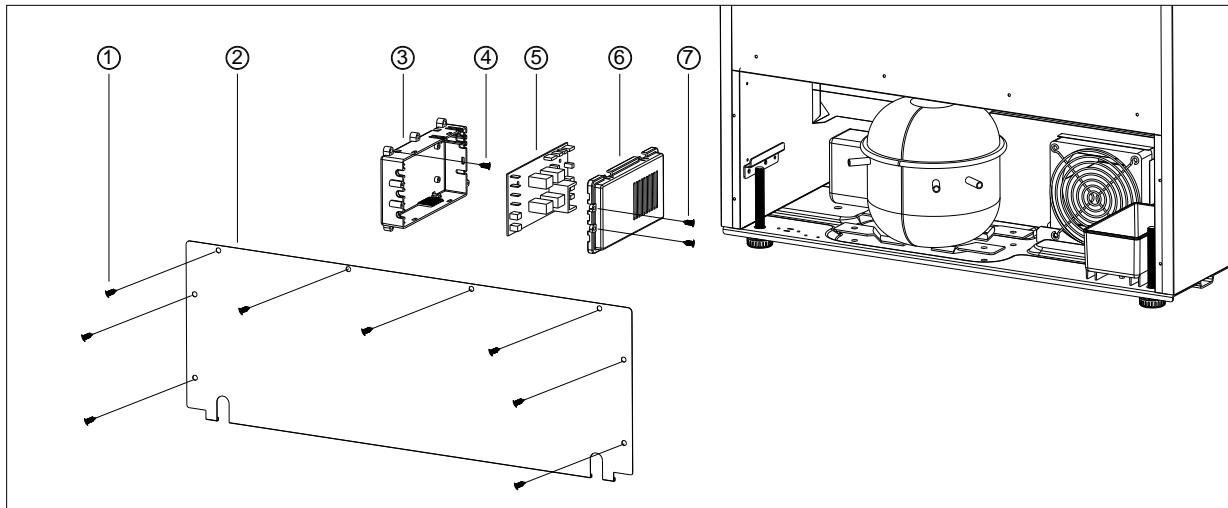

REPLACING THE LED LIGHT

1. Remove all shelves.
2. Remove the LED light cover ② by fingernail.
3. Pull out to remove the LED light PCB and replace it with a new one.

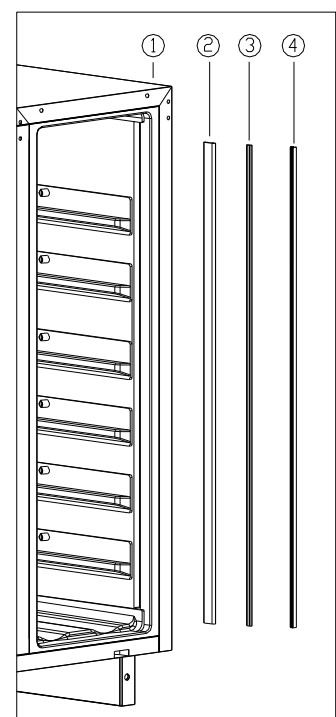

REPLACING THE EVAPORATOR FAN MOTOR, DEFROST SENSOR, TEMPERATURE SENSOR AND DEFROST HEATER IN THE UPPER ZONE FOR DUAL ZONE MODELS AND IN BOTH ZONES FOR TWIN WINE CONDITIONING MODELS

1. Remove all shelves in the corresponding zone.
2. Remove the screws ② ③ that secure the top air distributor ① to the cabinet.
3. Remove the thermistor cover ⑬ and now you can replace the temperature sensor ⑭ in the corresponding zone.
4. Remove the screws ④ that secure the air channel cover ⑥ to the cabinet.
5. Disconnect the wires to the evaporator fan motor ⑪. Then pull out the air channel cover.
6. Dismantle the silicon pins ⑤ that secure the fan motor ⑪ to the air channel cover and then you can replace the evaporator fan motor.
7. Find the defrost sensor ⑩ in the evaporator ⑦ and you can replace it.
8. Find the defrost heater ⑧ on the evaporator and you can replace it.

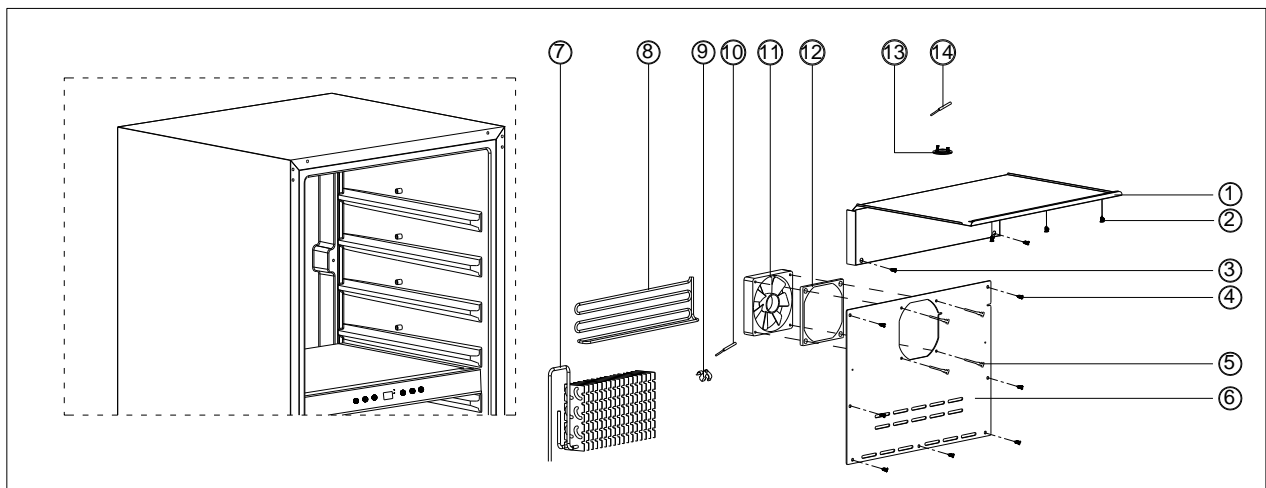

REPLACING THE HEATER, HEATER FAN MOTOR AND TEMPERATURE SENSOR IN THE LOWER ZONE FOR DUAL ZONE MODELS

1. Remove all shelves in the lower zone.
2. Remove the screws ② and ③ that connect the bottom air distributor ① to the cabinet and middle divider. Slide out and remove the bottom air distributor.
3. Remove the screws that secure the lower air channel cover ④ to the cabinet.
4. Disconnect the fan motor wires. Then pull out the lower air channel cover.
5. Now you can see the heater ⑩ for replacing.
6. Unscrew the thermistor supporter ⑧ and now you can replace the temperature sensor ⑦ in the lower zone.
7. Remove/disassemble the four screws ⑤ that secure the heater fan motor F2H ⑫ to the lower air channel cover and then you can replace it.

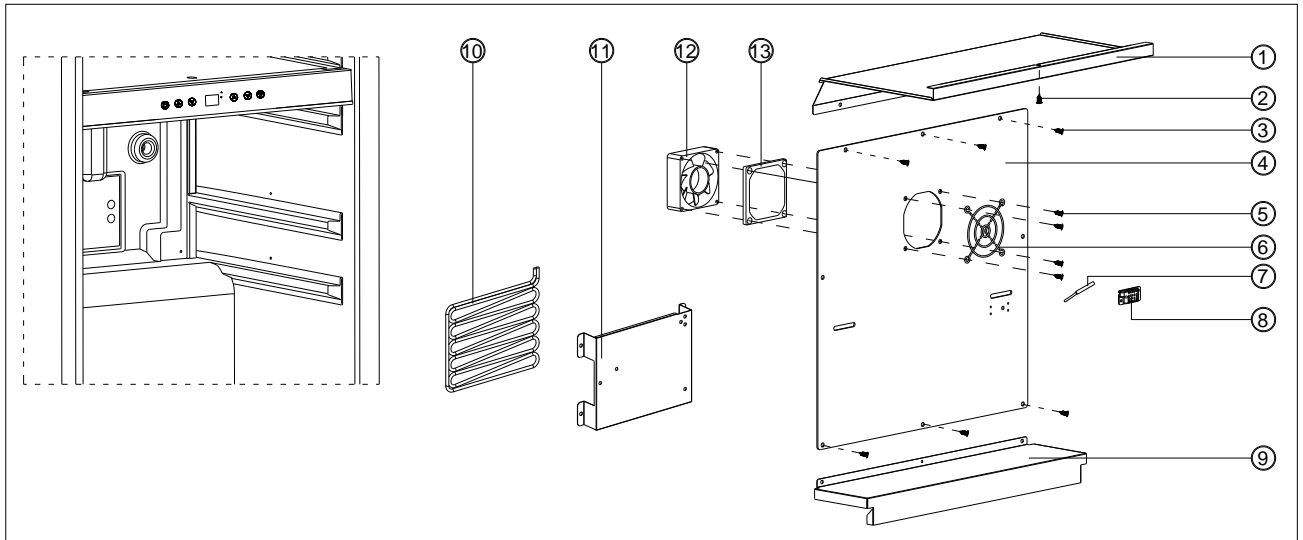

REPLACING THE EVAPORATOR ASSEMBLY

NOTE: Before replacing any component of the refrigeration system, make sure to read the instructions “Service Precautions for R600A System”.

1. Disconnect the unit from the power source.
2. Clean and then solder the capillary from the filter drier.
3. Clean and then solder the suction tube from the compressor.
4. Remove all shelves.
5. Remove the top air channel cover, bottom air channel cover and remove the middle divider for dual zone models.
6. Remove the air channel cover only for single zone models.
7. Remove the screws to fix the evaporator assembly to the cabinet.
8. Replace the evaporator assembly and install the new one to the cabinet.
9. Make the system flush and replace the filter dryer.
10. Clean then connect the suction tube to the compressor. Clean again and connect the capillary to the filter dryer.
11. Solder all joints. Silver solder and proper flux should be used on copper to steel or steel to steel joints. Excess flux should be wiped off all tubing.

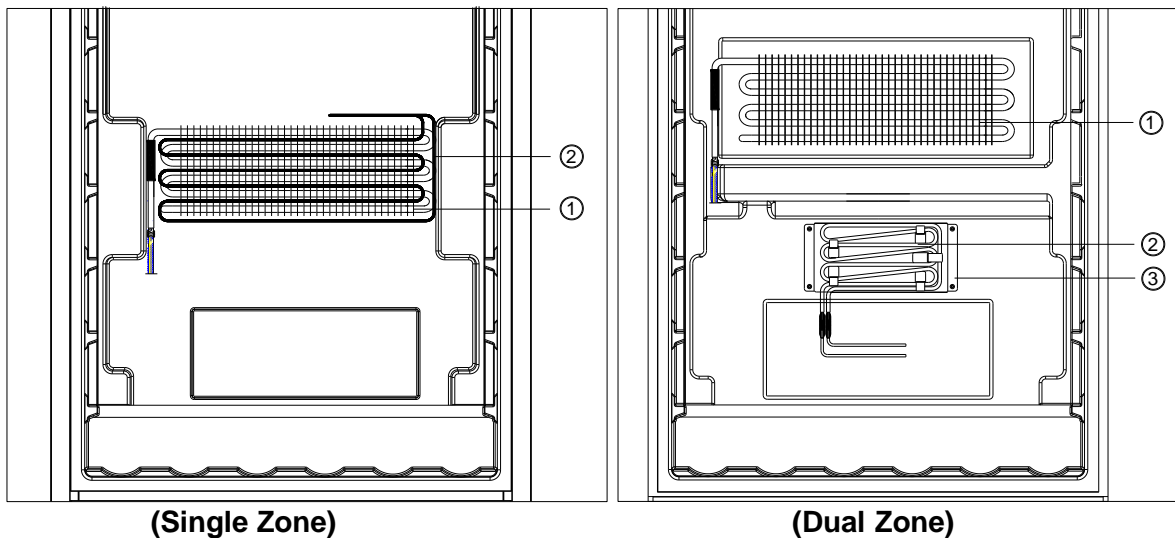

(Single Zone)

(Dual Zone)

REPLACING THE COMPRESSOR, COMPRESSOR PTC STARTER AND OVERLOAD PROTECTOR

NOTE: Before replacing any component of the refrigeration system, make sure to read the instructions "Service Precautions for R600A System".

All replacement compressors are charged with the correct amount of oil and a holding charge of dry nitrogen.

The holding charge is your assurance that the compressor is dry and ready to install. If you receive a replacement compressor that shows no evidence of holding charge when you center the lines or remove the plugs, return it.

1. Disconnect the unit from the source.
2. Locate defective compressor and evacuate the sealed system.
3. Clean and cut the refrigerant lines as close as possible to the compressor stubs, leaving enough length to install the replacement compressor.
4. Disconnect lead wires from compressor terminals.
5. Remove the retaining clips from the compressor mounts.
6. Remove defective compressor from cabinet and install rubber grommets on replacement compressor.
7. Clean the compressor stubs with an abrasive cloth. Do not open the compressor stubs.
8. Install the replacement compressor using the mounting clips previously removed.
9. Connect the compressor leads.
10. Solder a short piece of tubing to the process tube (approximately 150mm / 6 inches long).
Connect the refrigerant tubing to the compressor stubs.
11. Evacuate, recharge and leak test the system.
12. Test/run the unit to check operation.

REPLACING THE FILTER DRIER

NOTE: A new filter drier must be installed each time any component of the refrigeration system opened or replaced.

1. Carefully pull the old filter drier ② and tubing out of the compressor room.
2. Use steel wool or fine emery paper to clean the capillary tube ① 3 inches (75mm) from the original joint. Also, clean the input tubing ④ (the condenser outlet tube) to the filter drier of 3 inches from the original joint.
3. Use a knife or file to score the capillary tube and the input tubing to the old filter drier 1 inch (25mm) from the original joints. Then break the connections.
4. Use steel wool or fine emery paper to clean both ends of the new filter drier.
5. Make an offset 1/2" (12mm) from the end of the capillary tube to prevent it from penetrating too far into the drier.
6. Connect the capillary tube to the replacement filter drier.
7. Connect hot pipe inlet tube to the replacement filter drier
8. Solder the new filter drier using silver solder with the proper flux at the hot pipe to filter drier joint. Use silfos at the drier to capillary tube joint.

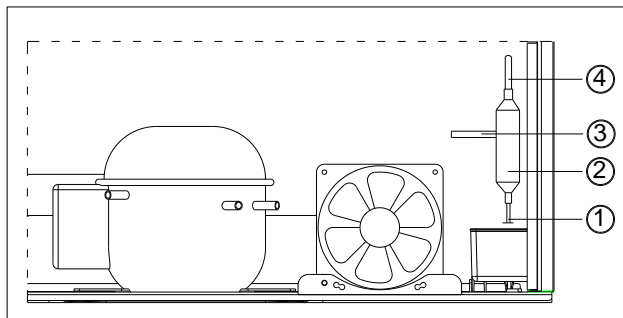

REPLACING THE SOLENOID VALVE

NOTE: Before replacing any component of the refrigeration system, make sure to read the instructions “Service Precautions for R600A System”.

1. Disconnect the unit from the source.
2. Locate the defective solenoid and evacuate the sealed system.
3. Clean and then solder the two capillary pipes and the filter drier from the old solenoid valve.
4. Disconnect lead wires from the old solenoid valve.
5. Remove the screw which secures the solenoid valve to the compressor base. Then screw the new replacement solenoid valve to the compressor base.
6. Replace the filter drier with a new one.
7. Clean all the tubes with an abrasive cloth. Connect all the corresponding tubes to the solenoid valve and solder them.

IMPORTANT:

- Make sure to connect the solenoid valve outlets to the capillary pipes correctly as below figure.

- During the soldering process, make sure to use the wet cloth to protect the solenoid valve including all inlet and outlet pipes from overheating. Overheating will destroy the plastic piston inside the solenoid valve and make the solenoid valve failed.

8. Connect the solenoid valve leads.
9. Solder and replace a short piece of tubing to the process tube (approximately 150mm / 6 inches long) of compressor.
10. Evacuate, recharge and leak test the system.
11. Test/run the unit to check operation.

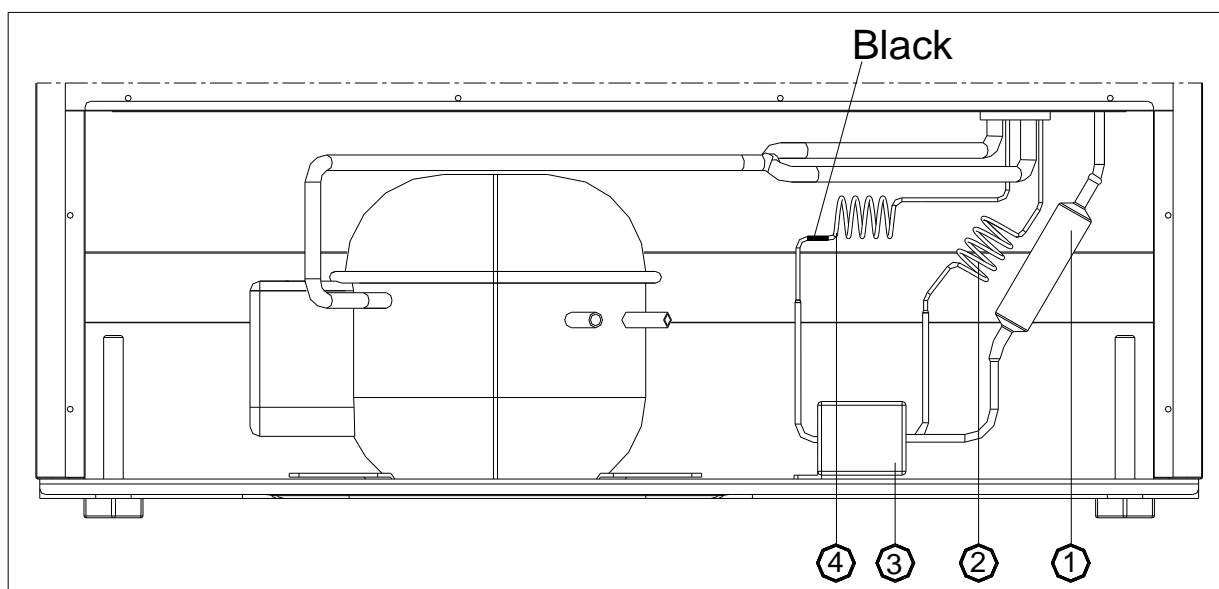

Remark: For other dual zone models, capillary pipe 4 marked in black is connected to the evaporator in the lower zone and capillary 2 is connected to the evaporator in the upper zone.

LEVELING THE DOOR

1. With assistance, tilt the unit back and loosen the screws marked "4".
2. Move the stop screw from position 1 to position 2 or 3 to make the door top is parallel with the cabinet top then tighten all the screws.
3. Moving the stop screw from position 1 to position 2, the bottom hinge plate together with the door can be moved towards the left direction with 0.5mm. Moving the stop screw from position 1 to position 3, the bottom hinge plate together with the door can be moved towards the left direction with 1.25mm.
4. If the door is still not leveled when the stop screw is positions 1, 2 or 3, bypass the stop screw and only use the screws marked "4" to fix the bottom hinge plate.

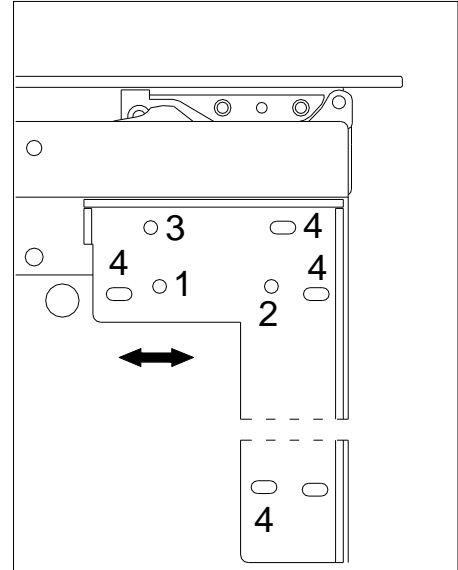

REPLACING THE DOOR GASKET

1. Open the door and detach the old door gasket ② from the door frame ① by pulling off the gasket. Start in a corner and pull outward. This may take some force.
2. Attach the new door gasket on the door frame. Be careful not to damage the door and the new door gasket.

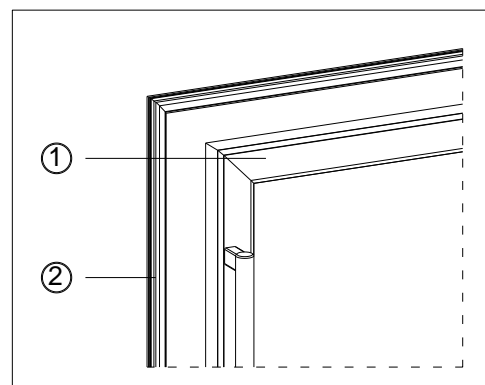



WC6130 & WC6530

Caple Fully Built-in Wine Cabinet

Troubleshooting & Error Codes



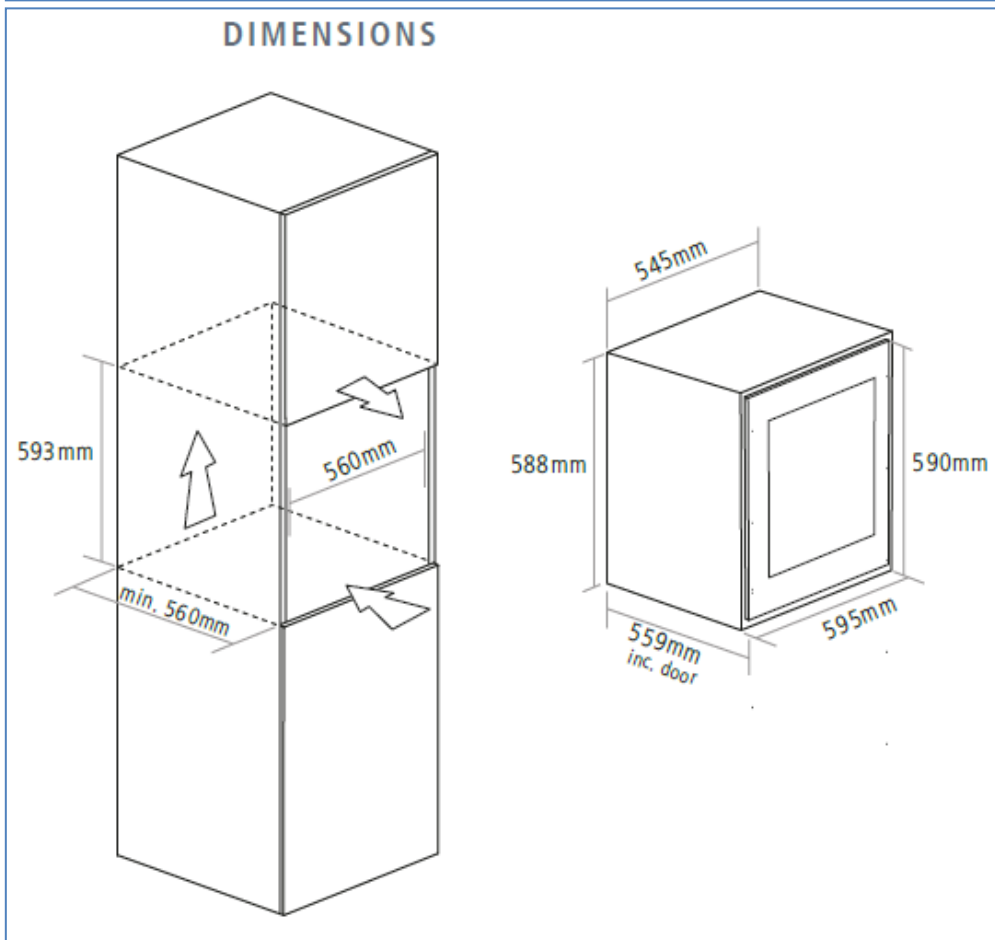
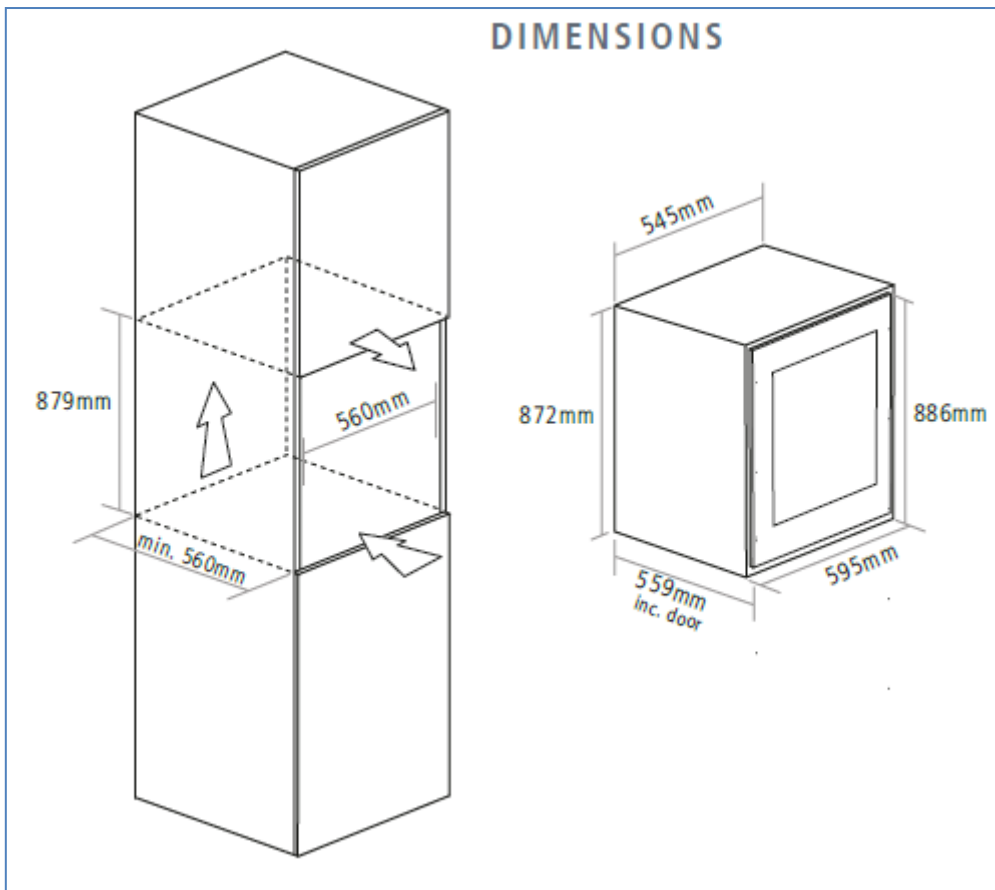

EFFICIENT VENTILATION:

Enjoy hassle-free installation with the self-ventilating feature of the WC6530 and WC6130 wine cooler, eliminating the need for a plinth grille as air is efficiently drawn beneath the appliance and expelled above the door back into the room.

TROUBLESHOOTING GUIDE

SYMPTOM	DIAGNOSIS
For models - Dual zone with single door	
The displayed temperature is higher than the set temperature in the upper zone.	<ol style="list-style-type: none"> 1. Is the ambient temperature too high more than 35°C? 2. Is the ventilation blocked? 3. Is the evaporate fan motor in the upper zone failed? 4. Is the condenser fan motor failed? 5. Is the temperature sensor failed? 6. Is the cooling system failed?
The displayed temperature is lower than the set temperature in the upper zone.	<ol style="list-style-type: none"> 1. Is the lower zone temperature normal? Otherwise check the PTC heater and fan motor in the lower zone. 2. Is the fan motor in the middle partition failed? 3. Is the temperature sensor failed? 4. Is the Main PCB or Display PCB failed? 5. Is the ambient temperature too low less than 0°C?
The displayed temperature is higher than the set temperature in the lower zone.	<ol style="list-style-type: none"> 1. Is the upper zone temperature normal? Otherwise check the upper zone problem firstly. 2. Is the fan motors in the middle partition failed? 3. Is the temperature sensor failed? 4. Is the ambient temperature too high more than 35°C?
The displayed temperature is lower than the set temperature in the lower zone.	<ol style="list-style-type: none"> 1. Is fan motor failed? 2. Is the air damper inside the middle divider failed? 3. Is the PTC heater failed? 4. Is the temperature sensor failed? 5. Is the Main PCB or Display PCB failed? 6. Is the ambient temperature too low less than 0°C?
The temperature in the upper zone is normal but the displayed temperature in the lower zone is lower than the set temperature.	<ol style="list-style-type: none"> 1. Is the fan motor in the lower zone is failed? 2. Is the PTC heater failed? 3. Is the isolation between the upper zone and lower zone not good?

TROUBLE CHECK FOR REFRIGERANT SYSTEM

Once it has been determined that the other electrical systems are working properly, a probable sealed system problem can be confirmed according to the below table when the unit is no cool or not cold enough.

No.	Symptom	Cause	Action
1	The evaporator cools down and warms again. The condenser warms in proportion as the evaporator cools. The process repeats again.	Moisture in the refrigerant causes the malfunction.	Replace the refrigerant.
2	The condenser is cold. The evaporator is not cold. The temperature of compressor is high.	Foreign substances hamper the cooling system.	Locate the troubled section and make repairs.
3	No difference in temperature between suction pipe and discharge pipe of compressor. The temperature of compressor is kept at room temperature level. The evaporator does not cool down.	Failed compressor.	Replace the compressor.
4	Frost on the suction pipe. The condenser is overheated. The refrigeration of evaporator is not efficient. The electric current of compressor is much larger than normal.	Overcharge.	Discharge the refrigerant. Charge refrigerant to the designated volume. Check for gas leak.
5	The condenser is cold. The compressor surface temperature is high. The refrigeration is not cold enough.	Short of refrigerant. Find the leaking position. NOTE: Note: If you can find oil on somewhere, it is possible where the leakage point is.	Discharge the refrigerant. Charge refrigerant to the designated volume. Check for gas leak.

SPECIAL DETAILED DIAGNOSIS

DETECT THE MAIN PCB & DISPLAY/CONTROL PCB

1. The control system including the MAIN PCB and DISPLAY/CONTROL PCB operates when the unit is powered. If not, the unit is either POWER OFF or Switch OFF. If neither operates, check the control system including the main PCB and Display/Control PCB and connecting wirings.

2. The first step is to check and see if there is any component failed in the PCBs by using your common sense.

3. To Check the Main PCB,

- Disconnect the unit from the power source.
- Dismantle the electrical box in the compressor room and take out the main PCB.
- Disconnect the lead connectors of all fan motors and compressor from the cable.
- Carefully place the main PCB so that it is insulated from any other part.
- Connect the unit to the power source.
- Check the output voltage of all fan motors and compressor connectors on the main PCB.

The correct output voltage of all fan motors connectors should be 12V DC. The correct output voltage of compressor connector should be same as the power source. If not, the main PCB must be replaced.

4. Replace the Display/Control PCB for the below symptoms after you confirm that the Main PCB is normal.

- No LED temperature display or indicator illuminated in the control panel.
- Some LEDs do not light.
- No response when touching the control marks. (For this kind of symptom, double check to see if there any response after disconnect the power before replacing the Display/Control PCB.
- The unit does not run correctly in the TEST MODE. In order to run in TEST MODE, Touch and hold the “**LIGHT**” and “**UP**” marks at the same time for 5 seconds.

5. If you can't find the failure from the existed symptoms, replace the Main PCB and Display/Control PCB separately to see which one is failed and then replace the failed PCB.

DETECT THE CONDENSER FAN MOTOR (F0)

1. The condenser fan motor operates in parallel with the compressor. If the compressor runs but the motor doesn't, the motor is either defective or disconnected. If neither operates, check the main PCB and the cabinet wiring.

2. To Check the Condenser Fan Motor,

- Disconnect the unit from the power source.
- Disconnect the condenser fan motor lead connector from the cable.
- Connect the condenser motor to a 12V DC power source. If the motor fails to operate, it is defective and must be replaced.

DETECT THE EVAPOARTOR FAN MOTOR (F1C/F1H)

1. The evaporator fan motor operates when the compressor operates and at the rest time it cycles ON and OFF to circulate the interior air. If the compressor runs but the motor doesn't, the motor is either defective or disconnected. If neither operates, check the main PCB and the cabinet wiring.

2. The evaporator fan motor also operates when the PTC heater operates for single zone models with heat function.

3. To Check the Evaporator Fan Motor,

- Disconnect the unit from the power source.
- Remove the air duct cover.
- Disconnect the evaporator fan motor lead connector from the cable.
- Connect the motor to a 12V DC power source. If the motor fails to operate, it is defective and must be replaced.

DETECT THE FAN MOTOR AND AIR DAMPER IN THE MIDDLE DIVIDER FOR DUAL

ZONE MODELS (F2C)

1. The fan motor F2C and air damper operate synchronously and independent from the compressor. When the set temperature of lower zone is not met, and lower than the actual storage temperature they operate and at the rest time they does not run. If the set temperature of lower zone is not met and lower than the actual storage temperature but the fan motor and air damper doesn't operate, the fan motor and air damper are either defective or disconnected if the thermostat in the lower zone is correct. If neither operates, check the main PCB and the cabinet wiring.

2. To Check the Fan Motor in Middle Partition,

- Disconnect the unit from the source.
 - Remove and dismantle the middle divider assembly.
 - Disconnect the fan motor lead connector from the cable.
 - Connect the motor to a 12V DC power source. If the motor fails to operate, it is defective and must be replaced.
3. To Check the Air Damper in Middle Divider,
- Disconnect the unit from the power source.
 - Remove and dismantle the middle divider assembly.
 - Disconnect the air damper lead connector from the cable.
 - Connect the air damper to a 12V DC power source. If it fails to operate, it is defective and must be replaced.

DETECT THE HEATER FAN MOTOR (F2H)

1. The heater fan motor operates when the heater in the lower zone operates and at the rest time it cycles ON and OFF to circulate the interior air if the unit is running in Eco mode.
If the heater runs but the motor doesn't, the motor is either defective or disconnected. If neither operates, check the main PCB and the cabinet wiring.
2. To Check the Heater Fan Motor,
 - Disconnect the unit from the power source.
 - Remove the bottom air channel cover.
 - Disconnect the heater fan motor lead connector from the cable.
 - Connect the motor to a 12V DC power source. If the motor fails to operate, it is defective and must be replaced.

DETECT THE HEATER

1. The heater operates when the set temperature is not met and lower than the actual storage temperature. If not, the heater is either defective or disconnected. If neither operates, check the main PCB and the cabinet wiring.
2. To Check the Heater,
 - Disconnect the unit from the power source.
 - Remove the air channel cover.
 - Disconnect the heater lead connector from the cable.
 - Connect the heater to a rated power source on the rating label. If the heater fails to operate, it is defective and must be replaced.

DETECT THE COMPRESSOR (NOT FOR INVERTER TYPE)

Testing the compressor with no other wiring in the circuit is called the direct test method.

Remove all electrical components (including the accessories - overload protector, starter relay and running capacitor) from the compressor in order to perform this test.

To Check the Compressor,

- Disconnect the unit from the power source.
- Remove all electrical components from the compressor.
- Using a power supply cord, connect the N lead to the common (C) terminal of the compressor and the L lead to the run (M) terminal of the compressor.
- Connect the compressor to a rated power source on the rating label. If the compressor fails to run, the compressor is defective and must be replaced.

OVERLOAD PROTECTOR

The overload protector prevents the compressor from burning out its electrical windings in the event the compressor becomes overheated or draws too much current. The overload trips, opening the circuit to the compressor. If it does this repeatedly, the compressor is said to be cycling on the overload. Cycling on the overload may be caused by:

1. Insufficient air circulation around the compressor and condenser.
2. Pull-down on the compressor, caused by a large quantity of warm food placed in the refrigerator.
3. Compressor stalling due to lack of pressure unloading.
4. Low line voltage.
5. Defective starter relay.
6. Defective winding in the compressor or shorted windings.

Testing the Overload Protector

Disconnect the unit from the power source.

To test the overload protector, remove the compressor terminal cover. Examine the bottom of the overload for signs of arcing. If signs of arcing are present, either check for continuity or connect a jumper wire across the terminals. If using a jumper wire, plug in the line cord and set the temperature control to a cold setting. If the compressor starts, the overload is defective and must be replaced. If the compressor fails to start, check for a defective start relay or compressor.

1. Remove the PTC starter relay and overload protector from the compressor.
2. Connect one ohmmeter probe to the compressor shell. Make sure the probe makes good contact with bare metal. One at a time, connect the other ohm-meter probe to each of the three compressor terminals.
3. If the meter shows no continuity to ground, install PTC and overload protector to the compressor's terminals. If the meter indicates the compressor terminals are grounded, replace the compressor.
4. Attach a jumper wire across the overload terminals.
5. Make sure the jumper wire does not short to ground.
6. Reconnect the unit to power source. If the compressor starts, the overload protector is defective and must be replaced.

PTC STARTER RELAY

The PTC solid state starting device is a push-on component mounted to the start and run terminals of the compressor. This device is connected in parallel with the run capacitor and is in series with the compressor start windings. This will produce a short circuit across the run capacitor during the compressor starting sequence and full current is applied to the start windings as well as the main winding. Since the PTC device is temperature sensitive, a variance in its temperature causes a change in its resistance. When current is first applied to the compressor, the PTC device's low resistance shorts out the run capacitor, thus producing adequate motor starting torque. As the compressor motor approaches running speed, the current through the PTC device causes the temperature and resistance of the PTC device to increase to where it appears to be an open circuit. The compressor continues to operate on the run winding in parallel with the series combination of the run capacitor and start winding.

Checking the PTC Device

1. Disconnect the unit from the power source.
2. Discharge the capacitor and remove the wires from the PTC device terminals.
3. Allow the PTC to cool to room temperature.
4. Remove the PTC device.
5. Using an ohmmeter, check the resistance between the PTC device terminals. The ohmmeter should register between 3 and 20 ohms. An extreme variance between 3 and 20ohms indicates a defective PTC device which must be replaced.

RUNNING CAPACITOR

The running capacitor is mounted adjacent to the compressor. It is electrically connected to the compressor circuit to provide the required phase difference between the start and run windings for running the compressor.

Capacitor Failures May Be Caused By:

- (1) A Short Circuit - Will cause the start windings to be energized continuously in the start mode. The compressor could start, but the overload protector will trip, and eventually trip continuously.
- (2) An Open Circuit - Should, under normal conditions, allow the compressor to start. Under a heavy running load, however, the compressor will trip on the overload.
- (3) A Capacitor Low in Capacitance – A capacitor may lose capacitance by a loss of its electrolytic properties. The compressor would run under a light load, but would trip on the overload in high ambient conditions.

Testing the Capacitor

We recommend using a capacitor analyzer when testing. A solid state unit that measures capacitance and power of any capacitor, and has an automatic means of discharging the capacitor through resistance is preferred.

Alternate Method Ohmmeter

1. Disconnect the unit from the power source.
2. Disconnect the capacitor lead wires.
3. Short across the terminals using a resistor with a minimum resistance of 1,000 ohms. This ensures that no charge remains to damage the ohmmeter.
4. Set the ohmmeter selector switch to the 10,000 ohm scale (R x 10K).
5. Connect the ohmmeter leads to the capacitor terminals and observe the meter point lower end.

ERROR CODES:

DISPLAY "E0"

"E0" indicates the communication error. It may be caused by the following reasons:

- The Control PCB is failed. – Replace the Control PCB.
- The wiring harness between the two control units (only for three temperature zone models) is wrong connected or failed such as the screw has made the wires open circuit.
 - Reroute a new wiring harness.
- No signal from humidity sensor (only for models with humidity sensor). – Change the humidity sensor PCB or reroute the connecting wires.
- No signal from solenoid valve Control PCB (only for models with solenoid valve). – Change the humidity sensor PCB or reroute the connecting wires.
- Loosed wires. – Connect firmly.

DISPLAY "E1"

"E1" indicates the corresponding air temperature sensor is open circuit. It may be caused by the following reasons:

- The temperature sensor is failed. – Replace the thermostat.
- The Power PCB is failed. – Replace the Power PCB.
- The Control PCB is failed. – Replace the Control PCB.
- The temperature sensor wire is loosed out of the connection terminal on the Power PCB.
 - Plug in firmly.
- The sensor wire is not connected with the internal line. – Connect reliably.
- The wiring harness is failed such as the screw has made the wires open circuit. – Reroute a new wiring harness.

DISPLAY "E2"

"E2" indicates the corresponding air temperature sensor is short circuit. It may be caused by the following reasons:

- The temperature sensor is failed. – Replace the thermostat.
- The Power PCB is failed. – Replace the Power PCB.
- The Control PCB is failed. – Replace the Control PCB.
- The wiring harness is failed such as the screw has made the wires short circuit. – Reroute a new wiring harness.
- Loose GND connection wire. – Plug in firmly.

DISPLAY "E3"

"E3" indicates the defrosting sensor on the evaporator is open circuit. It may be caused by the following reasons:

- The defrosting sensor is failed. – Replace the defrosting thermostat.
- The Power PCB is failed. – Replace the Power PCB.
- The Control PCB is failed. – Replace the Control PCB.
- The defrosting sensor wire is loosed out of the connection terminal on the PCB. – Plug in firmly.
- The sensor wire is not connected with the internal line properly. – Connect reliably.
- The wiring harness is failed such as the screw has made the wires open circuit. – Reroute a new wiring harness.
- The solenoid valve Control PCB is failed (For the models with solenoid valve). – Replace the solenoid valve Control PCB.
- Loosed wires. – Connect firmly.

DISPLAY "E4"

"E4" indicates the defrosting sensor on the evaporator is short circuit. It may be caused by the following reasons:

- The defrosting sensor is failed. – Replace the defrosting thermostat.
- The Power PCB is failed. – Replace the Power PCB.
- The Control PCB is failed. – Replace the Control PCB.
- The wiring harness is failed such as the screw has made the wires short circuit. – Reroute a new wiring harness.
- The solenoid valve Control PCB is failed (For the models with solenoid valve). – Replace the solenoid valve Control PCB.

DISPLAY "E5"

"E5" indicates the defrosting heater failed. It may be caused by the following reasons:

- The defrosting heater is failed. – Replace the defrosting heater.
- The connecting wire from defrosting heater to Power PCB is loosed. – Reconnect the wire firmly.
- The connecting signal wire (Heater 1) from Control PCB to Power PCB is loosed. – Reconnect the wire firmly.
- The defrosting sensor is failed. – Replace the defrosting thermostat.
- The Power PCB is failed. – Replace the Power PCB.
- The Control PCB is failed. – Replace the Control PCB.

DISPLAY "E6"

"E6" indicates the solenoid valve failed. It may be caused by the following reasons:

- The connecting wire from Solenoid valve to Power PCB is loosed. – Reconnect the wire firmly.
- The connecting signal wire (Heater 1) from Control PCB to Power PCB is loosed. – Reconnect the wire firmly.
- The Power PCB is failed. – Replace the Power PCB.
- The Control PCB is failed. – Replace the Control PCB.
- The solenoid valve Control PCB is failed. – Replace the solenoid valve Control PCB.
- Loosed wires. – Plug in firmly.
- Wrong connection of capillary pipe for left/upper zone and right/lower zone. – Correct the connection
- Restricted capillary tube. – Correct the capillary tube.
- Wrong connection of air temperature thermostat for left/upper zone and right/lower zone. – Correct the connection.
- The solenoid valve is failed. Please check the details as above. – Replace the solenoid valve.

DISPLAY "E7"

"E7" indicates the door switch failure. It may be caused by the following reasons:

- The door is not closed properly. - Open and close the door with a little more force.
- The door switch is defective. – Replace the door switch.
- The pushing bracket on the door is lost or not in the correct position. – Add/Reposition the pushing bracket.
- The door switch is not installed correctly, such as the push bar of door switch is tilted. – Correct the installation.
- The door is tilted. – Level the door.
- The Control PCB is failed. – Replace the Control PCB.
- The connecting wires from door switch to Control PCB is loosed. – Reconnect the wires firmly.

DISPLAY "E8"

"E8" indicates the ambient air temperature sensor is open circuit. It may be caused by the following reasons:

- The ambient air temperature sensor is failed. – Replace the ambient air temperature thermostat.
- The Power PCB is failed. – Replace the Power PCB.
- The Control PCB is failed. – Replace the Control PCB.
- The temperature sensor wire is loosed out of the terminal on the Power PCB. – Plug in firmly.
- The sensor wire is not connected with the internal line. – Connect reliably.
- The wiring harness is failed such as the screw has made the wires open circuit. – Reroute a new wiring harness.

DISPLAY "E9"

"E9" indicates the ambient air temperature sensor is short circuit. It may be caused by the following reasons:

- The ambient air temperature sensor is failed. – Replace the ambient air temperature thermostat.
- The Power PCB is failed. – Replace the Power PCB.
- The Control PCB is failed. – Replace the Control PCB.
- The wiring harness is failed such as the screw has made the wires short circuit. – Reroute a new wiring harness.

SELF CHECK OF CONTROL SYSTEM

The Display/Control PCB has the self check function.

Press and hold the “**LIGHT**” and “**UP**” keys (only the **UP** key of lower/right zone is functional for dual zone LED display units) at the same time for 5 seconds, the unit will activate the self - check program. Below symptoms can be seen, otherwise replace the PCBs:

- LED indicators will be ON one by one.
- LED light will be ON.
- Temperature reader LED will display from 00 to 99.
- Fan motor, compressor and heater will be ON.

After the self-check program has been finished the unit will automatically go into the normal operation program.

TEST MODE – COOLING/HEATING

Press and hold the “**LIGHT**” and “**DOWN**” keys (only the **DOWN** key of upper zone is functional for dual zone LED display models with non - twin wine conditioning) at the same time for 5 seconds with power ON, the unit will run in the TEST MODE - COOLING. The compressor and all fan motors will operate continuously & independent from the SET temperature. At the same time the display shows the icon “--”.

The TEST Mode will automatically turn off after 10 minutes or you can stop the TEST mode by disconnect the unit from power source.

For the LED display models with twin wine conditioning system, pressing and holding the “**LIGHT**” and “**DOWN**” of upper/left zone keys at the same time for 5 seconds with power ON can activate the upper/left zone to run in TEST MODE - COOLING. pressing and holding the “**LIGHT**” and “**DOWN**” of lower/right zone keys at the same time for 5 seconds with power ON can activate the lower/right zone to run in TEST MODE -COOLING.

SENSOR RESISTANCE CHARACTERISTICS TABLE

No.	MEASURED TEMPERATURE (°C)	RESISTANCE OF SENSOR (kΩ)
1	-30	116.55
2	-28	104.97
3	-26	94.67
4	-24	85.49
5	-22	77.30
6	-20	69.99
7	-18	63.44
8	-16	57.58
9	-14	53.32
10	-12	47.60
11	-10	43.35
12	-8	39.53
13	-6	36.08
14	-4	32.97
15	-2	30.16
16	0	27.62
17	2	25.32
18	4	23.24
19	6	21.35
20	8	19.63
21	10	18.07
22	12	16.65
23	14	15.35
24	16	14.17
25	18	13.10
26	20	12.11
27	22	11.21
28	24	10.39
29	25	10.00
30	26	9.63
31	28	8.94
32	30	8.30
33	32	7.72
34	34	7.18
35	36	6.69
36	38	6.23
37	40	5.81
38	42	5.42
39	44	5.06
40	46	4.73
41	48	4.43

- The tolerance of sensor resistance is $\pm 5\%$
- Be sure to measure the sensor resistance after keeping the sensor more than 3 minutes at a measuring temperature. (It needs delay due to sensor speed.)

ELECTRICAL AND CONTROL SYSTEM

CONTROL DESCRIPTION

FUNCTIONS

Cooling mode:

When the set temperature is lower than the storage temperature, the unit operates in cooling mode with compressor ON.

Heating mode:

When the set temperature is higher than the storage temperature, the unit operates in heating mode with heater ON.

Eco mode:

In the Eco mode, the interior fan cycles on and off to circulate the inside air evenly even the set temperature is reached. Eco mode is NOT the factory preset mode because of creating noises and more energy consumption. In the SILENT mode (Also known as energy saving mode), the appliance will run without the fan once the set temperature is reached. This Eco mode enables the relative humidity inside the unit and the temperature to be distributed evenly around the interior so you can store all your wine under exactly the same excellent conditions. If you would like to use the unit to store wine long term, the Eco mode is a must. This will create a continuous climate in the cabinet which imitates that of a wine cabinet.

Demo mode:

Demo mode can be activated by presenting the appliance at exhibitions or in salesrooms. In Demo mode, the compressor and all fan motors are switched OFF.

By pressing and holding the "UP"&"DOWN" (The controls of upper/left zone for dual zone LED display models) and "LIGHT" keys at the same time for at least 5 seconds, the indicator light will flash five times to confirm the input and the unit will operate in Demo mode. The indicators for Fahrenheit and Celsius degree will be ON. Demo mode can be cancelled by repeating the above process.

NOTE: To perform the multi-key function, press and hold the first key, then press the rest key the required number of times and then release all the keys.

SABBATH Mode:

Sabbath mode is available for the observance of certain religious holidays. This mode turns off the displays, interior light and audible alarms and prevents them from turning on again. Normal cooling operations will still take place. To initiate Sabbath mode, press the POWER and LIGHT keys at the same time for at least 5 seconds. The displays and interior lights will go out to confirm the Sabbath mode is ON. Sabbath mode can be cancelled by repeating the above process. The Sabbath Mode will automatically turn off after 48 or 96 hours.

ALARM SYSTEM

Temperature Display

During normal operation, the temperature displays on the control panel show the temperatures inside the appliance. The temperature display will flash if

- A different temperature is being set,
- The temperature in one of the zones deviates by more than 5°C from the set temperature.

The temperature display flashing ensures that the temperature can't rise or fall un-noticed and impair the wine.

To view the "set" temperature at any time, touch the "UP" or "DOWN" mark, the "set" temperature will temporarily flash in the LED display for 5 seconds for LED display models. For LCD display models, touch the Setting Selector key, the set temperature will temporarily flash in the display for 5 seconds.

If the LED readouts display the icon "--" and flash, that means the display temperature is out of the range from -9 to 37°C for Celsius degree and from 16 to 99°F for Fahrenheit degree. That is normal.

Temperature Alarm

An alarm will sound if the temperature in one of the zones rises or falls outside the temperature range. The relevant temperature display will flash at the same time.

The temperature the appliance is set at determines the temperature the appliance recognizes as being too warm or too cool.

The alarm will sound and the temperature display will flash:

- When you switch the appliance on, if the temperature inside the appliance is very different from the temperature set.
- When there has been a lengthy interruption to the power supply.
- When too many items have been put into the unit at one time.
- When the door is not been closed tightly.

Door Alarm

If the door has been left open for more than 60 seconds, the alarm will sound.

Once the set temperature has been reached in the appliance, the alarm stops and the relevant temperature display stops flashing. However, if the noise disturbs you, you can switch the alarm off before this if you wish by pressing any key once. The alarm will stop. The relevant temperature display continues to flash until the set temperature has been reached. The display then lights up constantly, and the alarm system is fully active again.

OTHER FUNCTIONS

Temperature Memory Function

In the event of a power interruption (power surge, breaker switch, etc.), the unit can remember the previous temperature settings, and when the power is recovery, the unit will operate with the last temperature set-point and the cabinet temperature will go back the same setting temperature as power off.

Interior Light

The interior light makes it easy to view your wine labels and enhances the display of your collection. Touching and hold the LIGHT mark for 5 seconds toggles between 2 modes of operation for the internal lights: functional (default) mode and showcase mode. If you are in functional (default) mode, the lights will turn on only when the door is open. If you are in showcase mode, the lights will be on whether or not the door is open.

Defrosting

The defrosting is performed each time when the total running time of the compressor reaches 10 hours. During the defrosting cycle, the compressor is OFF and the fans and/or the defrost heater will operate continuously. After 30 minutes, the defrosting cycle will end. During the defrosting cycle, the storage temperature may vary by 3 or 4 degrees. That is normal. However, the frost may be accumulated on the evaporator if the unit is repeatedly opened in a high heat or high humidity location. If this frost pattern does not clear within 24 hours, your unit will require manual defrosting. The defrosting is performed each time when the total running time of the compressor reaches 10 hours. During the defrosting cycle, the compressor is OFF and the fans and/or the defrost heater will operate continuously. After 30 minutes, the defrosting cycle will end. During the defrosting cycle, the storage temperature may vary by 3 or 4 degrees. That is normal. However, the frost may be accumulated on the evaporator if the unit is repeatedly opened in a high heat or high humidity location. If this frost pattern does not clear within 24 hours, your unit will require manual defrosting.

SETTINGS MODE

Certain settings on the wine cabinet can only be selected in Settings mode. In Settings mode only the UP and DOWN keys of lower/right zone are functional for dual zone LED display units.

Touch and hold the UP key for 5 seconds to enter and leave Settings mode. The appliance will leave Settings mode automatically after approximately one minute.

°F/°C Selection

Lightly touch and hold the UP key for 5 seconds to enter Settings mode. Use the UP and DOWN keys to select the temperature display setting in Fahrenheit or Celsius degree. Touch and hold the UP key for 5 seconds to confirm the selection.

Display Brightness

Lightly touch and hold the UP key for 5 seconds to enter Settings mode and then touch the POWER key once. Use the UP and DOWN keys to select the brightness of the display when the door is close. When the door is open, the display brightness returns to its normal level.

d0: off

d1: dimmest setting (default)

d2: medium setting

d3: brightest setting

Touch and hold the UP key for 5 seconds to confirm the selection.

Interior Lighting Brightness

Lightly touch and hold the UP key for 5 seconds to enter Settings mode and then touch the POWER key twice. Use the UP and DOWN keys to select the brightness of the interior lighting when the door is closed. When the door is open, the interior lighting returns to its normal level.

L0: off when the door is close or open

L1: dimmest setting

L2: medium setting

L3: brightest setting (default)

Touch and hold the UP key for 5 seconds to confirm the selection.

Fan Mode

Lightly touch and hold the UP key for 5 seconds to enter Settings mode and then touch the POWER key three (3) times. Use the UP and DOWN keys to select the fan mode.

F0: Eco fan - Energy saving mode (default). Fan will operate until the set temperature is reached.

F1: Intermittent fan - half time. Fan will turn on/off regularly even when set temperature is reached.

F2: Intensive fan - full time. Fan operates continuously even when set temperature is reached.

Touch and hold the UP key for 5 seconds to confirm the selection.

Note:

Intermittent & Intensive fan modes further improve the temperature accuracy within the cabinet however will increase the noise level and energy usage as well.

Audible Tones

Lightly touch and hold the UP key for 5 seconds to enter Settings mode and then touch the POWER key four (4) times. Use the UP and DOWN keys to select the audible tones.

S0: sensor tone ON, alarm tone OFF

S1: sensor tone ON, alarm tone ON (default)

S2: sensor tone OFF, alarm tone OFF

S3: sensor tone OFF, alarm tone

Touch and hold the UP key for 5 seconds to confirm the selection.

FAQ

What are the storage conditions of concern to collectors and consumers to fine wine?

Light, humidity, temperature, vibration and odours/ventilation.

Don't forget that wine is a passion.

Complex - it evolves very slowly, peacefully!

It needs a combination of many conditions in order to blossom and quietly reach its summit.

The permanence of these conditions is crucial!

To start, it is necessary to make the distinction between ageing temperatures, preservation temperatures and tasting temperatures.

The 5 golden rules to make this distinction are:

The ageing temperature: designates a range of temperatures between 11 and 14°C; ideally, around 12°C, whatever the type of wine to be preserved and aged. But, more than the levels, it is the constancy of the temperature during the ageing period which will allow the wine to fully blossom. Therefore, it is important to avoid any brutal thermal shock.

Humidity: the bottles' cork must be kept permanently humid in order to remain hermetic.

At a persistent relative humidity below 50 %, the bottles' cork dries out and the wine flows and oxidizes.

At a persistent relative humidity above 80 %, mildew and mould may appear and labels may get unstuck.

Odours/ventilation: wine breaths through its cork. In the constant proximity of odours, wine denatures.

Vibrations: vibrations cause wine fatigue and disturb its evolution. This is why it is crucial to keep the wine safe from any movement.

Light: light increases the oxidation-reduction potential of wine, accelerating its ageing. This is why it is important to offer it true protective darkness.

In addition, to all this, a basic concept has to be considered:

It's absurd to preserve a wine with loving care for years, and then "kill" it by serving it at an inappropriate temperature. When served too cold, a wine's aromas are anaesthetized and its defects are hidden. When served too warm, it will become unbalanced by too much alcohol.

The serving temperature is the range of temperatures at which a wine should be served and consumed: from 7°C for "Liquoreux" wines up to 18°C for red tannic vintage wines.

It is important that these conditions be permanently satisfied!

Let's recapitulate your needs which led to your choice:

Do you purchase young wines and lovingly let them age? You are in the domain of **ageing!**

Do you purchase wines and champagnes close to their summit to have those near at hand and so be able to savour their rich aromas at the right temperature? You must follow a **multi-purpose approach**, with reservation and conditioning to temperature!

Do you wish to consume your "cru" wines at the right temperature? A **conditioning** wine cabinet will be really appropriate for you (also called a wine serving temperature cabinet).

What is the ideal temperature for wine?

The ideal temperature to store wines is between 52°F and 57°F (11°C~14°C). However, any temperature between 41°~72°F (5°~22°C) will suffice as long as it remains constant.

Type of Wine Recommended Drinking Temperature

Conservation 49 ~ 57°F 10 ~ 14°C

Red Wines 58 ~ 72°F 15 ~ 22°C

Dry/White Wines 48 ~ 57°F 9 ~ 14°C

Rosé Wines 49 ~ 51°F 10 ~ 11°C

Sparkling Wines 41 ~ 47°F 5 ~ 8°C

What is the ideal humidity for wine?

Humidity between 60%-70% is a superlative range in which to store wine. High humidity levels keep moisture inside the bottle thus preventing evaporation through the cork. Humidity levels that are too high often cause microorganisms to grow which can age your wine prematurely or even spoil your wine.

But, whatever happens, do not panic if you observe an abnormal temperature or relative humidity value inside your wine cabinet!

Only an extended and persistent exposure of your wines to these abnormal conditions might prove detrimental to them.

The traditional view on humidity maintains that wines should be stored on their sides in 50% - 80% relative humidity to ensure cork moisture and proper fit in the bottle. Contemporary wisdom suggests that the cork surface is too small to be impacted by humidity. Further, the cork is sealed with a metal or wax capsule making humidity penetration impossible. The concept of a humid storage environment was derived from the necessity of wineries to maintain moisture in their cabinets to keep wooden barrel staves swollen, preventing wine evaporation and product loss. In fact, vineyards estimate as much as a 10% product loss per year due to evaporation while wine is aging in the wooden barrels. Humidity, however, was not intended for the modern cabinet where wine is stored in glass bottles with sealed corks and flat laying.

The storage temperature seems to vary by 3 or 4 degrees frequently.

This is normal: small differences in temperature are necessary for the unit to work properly.

When the cabinet starts a defrost cycle, the temperature rises slightly. When the cooling system resumes working, the temperature cools down.

Such changes happen over a short time and their influence is too minimal to affect wine preservation. Liquid tends to keep an average temperature by physical law. For example, if a swimming pool's temperature is at 25°C and, one night, outside temperature drops to 18°C, the water's temperature will not drop as much. In the morning, it might only be at 22°C.

The true temperature to take into account is the temperature in the bottle. Instantaneous variations which you can read correspond to the compressor's operating cycles and stops.

It is thanks to this principle of small variations repeated in the air of your wine cabinet that a favourable average temperature is obtained to ensure your wines the best conditions of maturity.

Our wine cabinets are extensively insulated to ensure a temperature as stable as possible for your wines.

Consequently, a variation of 1°C in the temperature outside the bottle will only be evidenced by a temperature variation of approximately 0.1°C in the liquid.

Relative Humidity

What should be the average relative humidity in your wine cabinet?

1. The ideal average relative humidity should be between 60 and 70%; do not mistake this value for the instantaneous value which varies as a function of the compressor's operating cycles. Just like for the average temperature, it is this average relative humidity value which counts.
2. Depending on the geographical zones and their relative humidity in the air, more water may or may not have to be added.

In temperate countries, the relative humidity contained in the air is between 50 and 80 %.

Therefore, it is not necessary to add water, but it should be regularly checked.

The average relative humidity of my wine cabinet remains persistently below 50%: are you sure? (Relative humidity fluctuates a lot and rapidly - this is normal)

1. Check whether the activated charcoal filter is too old or simply obstructed.
2. Make sure that your hygrometer is operating correctly.
3. If you moisten a cloth every 2 hours, it will never be dry. This principle applies to corks. The constancy of the relative humidity average allows corks to preserve their elasticity, which is indispensable. Therefore, remember that an instantaneous value which seems low is normal, because it will necessarily rise later.

The relative humidity in my wine cabinet remains persistently above 80%. Are you sure? (Relative humidity fluctuates a lot and rapidly - this is normal):

1. Check whether the activated charcoal filter is too old or simply obstructed.
 2. Make sure that your hygrometer is operating correctly.
 3. If you moisten a cloth every 2 hours, it will never be too wet. This principle applies to corks.
- The constancy of the relative humidity average allows corks to preserve their elasticity, which is indispensable. Therefore, remember that an instantaneous value which seems high is normal, because it will necessarily drop later.

My bottles' labels un-stick:

1. Your wine is not threatened, but the relative humidity in your wine cabinet is too high.

How to choose your wine cabinet?

Do you purchase young wines and lovingly let them age? You are in the domain of **ageing!**

Do you purchase wines and champagnes close to their summit to have those near at hand and so be able to savour their rich aromas at the right temperature? You must follow a **multi-purpose approach**, with preservation and conditioning to temperature!

Do you wish to consume your "cru" wines at the right temperature? A **conditioning** wine cabinet will be really appropriate for you (also called a wine serving temperature cabinet).

Water has accumulated on the floor or appeared in the back of the appliance.

Make sure the drainage hose from inside the unit to the back water drip pan is properly in place. If so, during humid times, you may need to remove excess water with a sponge.

Water has appeared in the inside wall of the appliance.

During highly humid times, especially during summer, this can happen when opening the door too often.

The appliance never seems to stop: the unit is always on.

Make sure the door is closed properly. Add a separate thermometer inside the cabinet to see if the cabinet thermostat indicates the same temperature. If the results are different, replace the thermostat or Control PCB or Main PCB.

Mist/Condensation has appeared on the glass door.

During highly humid times, especially during summer, this can happen. For the high temperature and high humidity area, suggest you to buy our models with anti-condensation function.

Interior fan motors cycle on and off even the set temperature has been reached

In order to circulate the air and maintain the set temperature inside the cabinet the inside fans must cycle on and off when the compressor is off in Eco mode. The fans will cycle ON and OFF approximately every 50 seconds or 5 minutes. This cycle is normal and meant both to circulate the air as well as ensure the continued operational status of the fans. If the fan stops completely and does not complete this cycle the fan is non-operational if the unit is not in Silent mode.

Dynamic Cooling is NOT the factory preset mode. If the user feels noise, the user can select the SILENT mode by pressing and holding the UP key for at least 5 seconds and you can hear "B B B" three sounds to confirm silent mode is on.

Cannot get the upper and lower temperatures to set separately - they both adjust at the same rate (if you sets one higher the other goes higher etc).

This is normal. The temperature set for the LOWER ZONE must always be the same or higher than that in the UPPER ZONE. So when the user is adjusting the set temperature for one of the zones, if the above condition can't be met, the set temperature of the second zone will change automatically to meet the condition.

The control panel doesn't seem to work.

This unit's control panel outside of the cabinet has a Child Lock feature that prevents tampering with temperature or power settings. This feature activates automatically 2 minutes after the last touch of a key on the control panel. To unlock the control panel, press and hold the UP and DOWN keys for 5 seconds.

The fans are running constantly. Is it normal?

In order to circulate the air and maintain the set temperature inside the cabinet the inside fans must cycle on and off when the compressor is off in Eco mode. The fans will cycle ON and OFF approximately every 50 seconds or 5 minutes. This cycle is normal and meant both to circulate the air as well as ensure the continued operational status of the fans. If the fan stops completely and does not complete this cycle the fan is non-operational if the unit is not in Silent mode.

Digital display functions. But the unit does not cool.

Check to see if the unit is in "Eco Demo mode". Press and hold the "UP", "DOWN" and "LIGHT" keys at the same time for at least 5 seconds to exit Eco Demo mode.

Digital display, light and sound do not work but the unit is cooling well.

The unit is in Sabbath mode.

Abnormal noise / Normal noise

- Compressor Noise

- The working of the electrical motor and the pump inside the compressor will cause noise during the run time. The noise should be stable and not exceed 42 dB (A). If the noise is excessive, the compressor is failed and should be replaced.
- The aging rubber legs or incorrect leg mounting (Too loose or too tight) also generate the abnormal noise. If so, please correct the leg mounting or replace the legs.

- Fan Noise

- The working of fan motor will cause noise during the run time. The noise is stable and not exceeds 40 dB(A). If the noise is excessive, checking the following:
 - If the bearing of fan motor is failed, replace the fan motor.
 - If the fan interferes with the wirings, fix the wirings.

- Refrigerant Flow Noise

- The end of the capillary tube was inserted too far into the inlet pipe of evaporator. Or there are burrs at the end of the capillary tube.
 - The anti-vibration damp wraparound the joint of capillary and inlet tubing of evaporator is lost.
 - The capillary is interfered with the other parts.
 - The compressor oil has been flow to the refrigeration tubing during transportation.
- Perform the system flush, sweep and recharge.

- Normal Noise

All models incorporate rigid foam insulated cabinets to provide high thermal efficiency and maximum sound reduction for its internal working components. In spite of this technology, your model may make sounds that are unfamiliar.

Normal operating sounds may be more noticeable because of the unit's environment.

Hard surfaces such as cabinets, wood/vinyl/tiled floors and panelled walls have a tendency to reflect normal appliance operating noises.

Common refrigeration components, and a brief description of the normal operating sounds they make, are listed below:

- Compressor: The compressor makes a hum or pulsing sound that may be heard when it operates.
- Evaporator/Capillary: Refrigerant flowing through an evaporator may sound like boiling liquid.
- Condenser/Evaporator Fan: Air moving through a condenser may be heard.
- Automatic Defrost/Drain Pan: Water or ice may be heard dripping or running into the drain pan when the unit is in the defrost cycle.
- At the end of each cycle, you might hear a bubbly noise coming from the fluid circulating in the pipes.
- The interior walls contracting and expanding may also cause clicking or cracking sounds.