



# S700

**Caple 700 Island Hood**



**TECHNICAL INFORMATION**



# S700

## Caple 700 Island Hood

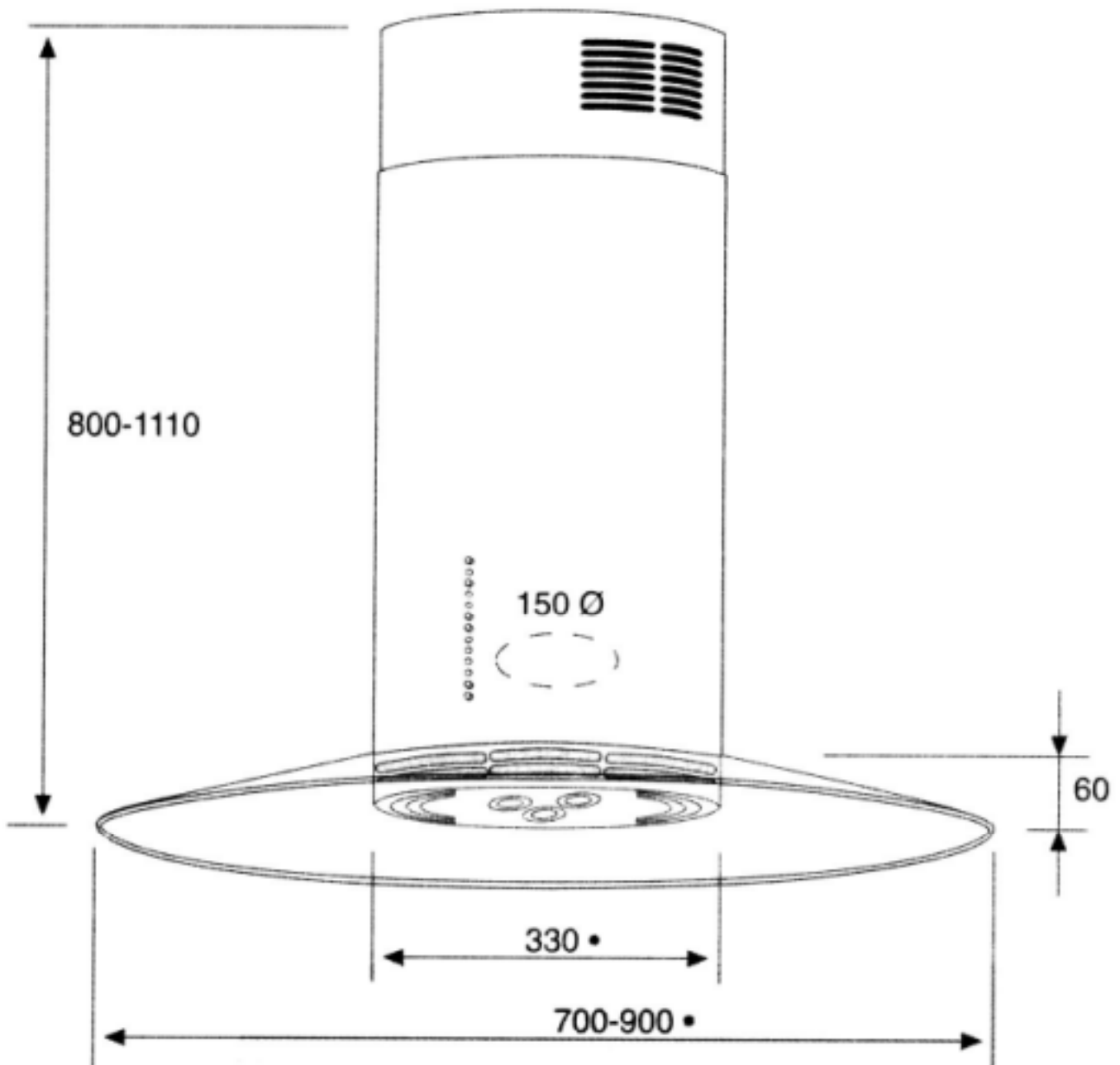

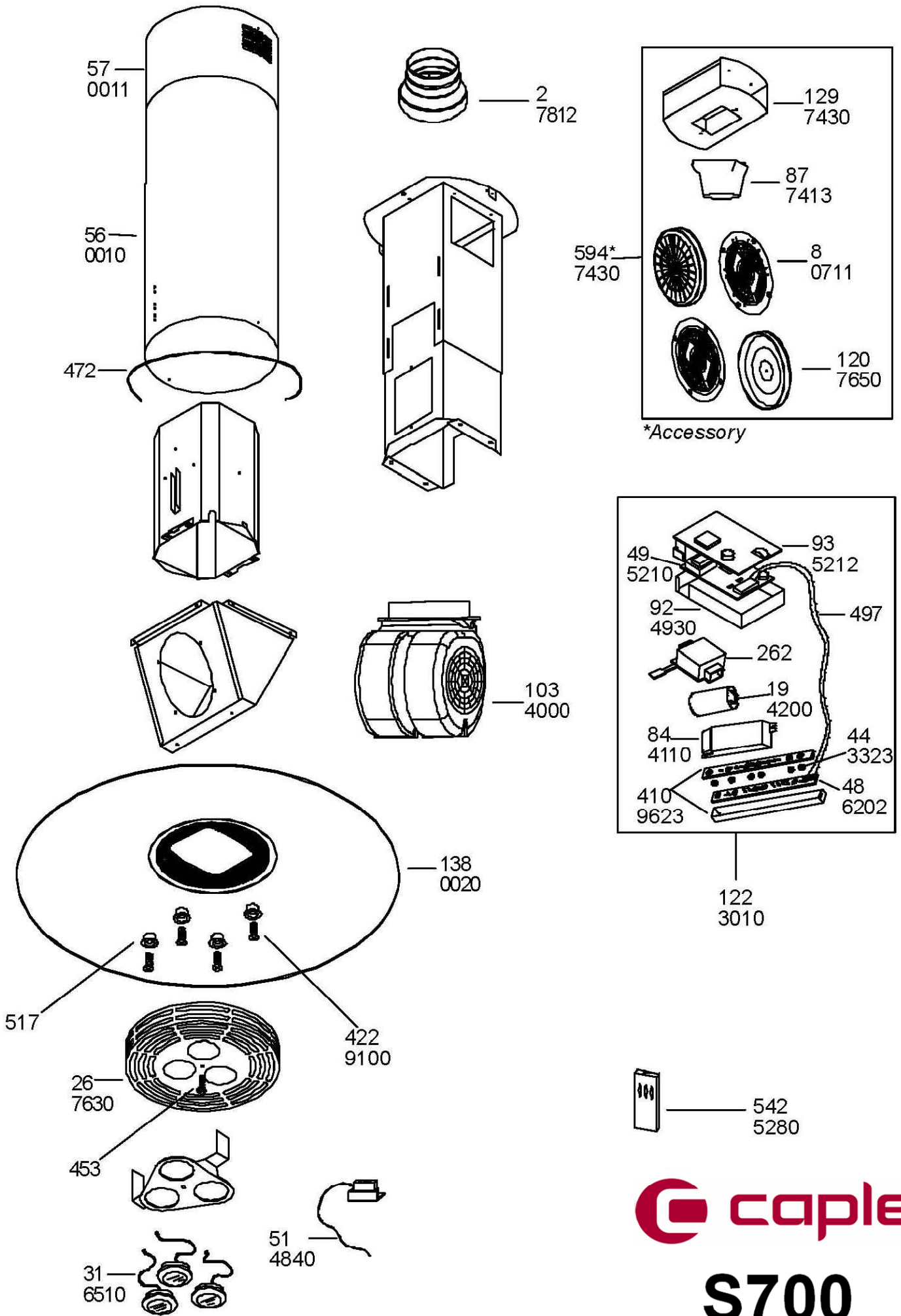

**caple**

**S700**

Caple 700 Island Hood  
Stainless Steel & Glass



# S700

## Caple 700 Island Hood Stainless Steel & Glass

19	2029U	CONDENSATORE 5 MF CAPACITOR
26	D2018A	GRIGLIA ISOL-2000 INX/SA+F/ALL
31	E0302	FARETTO LAMP
44	G010	TASTO CONTROL KEY
48	BE069A	BASETTA COMANDI CIRCUIT BOARD
49	BE06WA	SCHEDA ELETTR. ELECTRONIC VARIATOR
51	E114/R	CONTATTIERA 3 ATTAC.AMP FEMM.C
56	L9819	CAMINO INFERIORE BOTTOM CHIMNEY SECTION
57	D1211	CAMINO SUPERIORE UPPER CHIMNEY SECTION
84	2023U	TRASFORMATORE TRANSFORM
92	3049AR	SCATOLA CONNESSIONE ELECTRIC PLANT BOX
93	3064EI	PROTEZIONE IMPIANTO ELETTRICO ELECTRICAL CONNECTION PROTECTION
103	E1405	MOTORE COMPLETO COMPLETE MOTOR
120	2JET015	CONF.FIL.CARB.D200 NEUT(N-10) CARBON FILTER
262	PA0200	SCATOLA CONNESSIONE ELECTRIC CONNECTION BOX
410	PA037	CRUSCOTTO COMANDI COMMAND BOX
422	VT029A	VITE FIX VETRO GLASS CLAMPING SCREW
453	M085	POMELLO FILTRO COMPLEX CONVEYOR HOLDER
472	3016BG	PROFILO IN GOMMA RUBBER GASKET
497	E115	CONNETTORE SPRING SUPPORT
517	3025B	BOCCOLA ZAMA WASHER
542	E15	TELECOMANDO REMOTE CONTROL
594	2JET156	KIT FILTRANTE ISOLA 2000 FILTER KIT

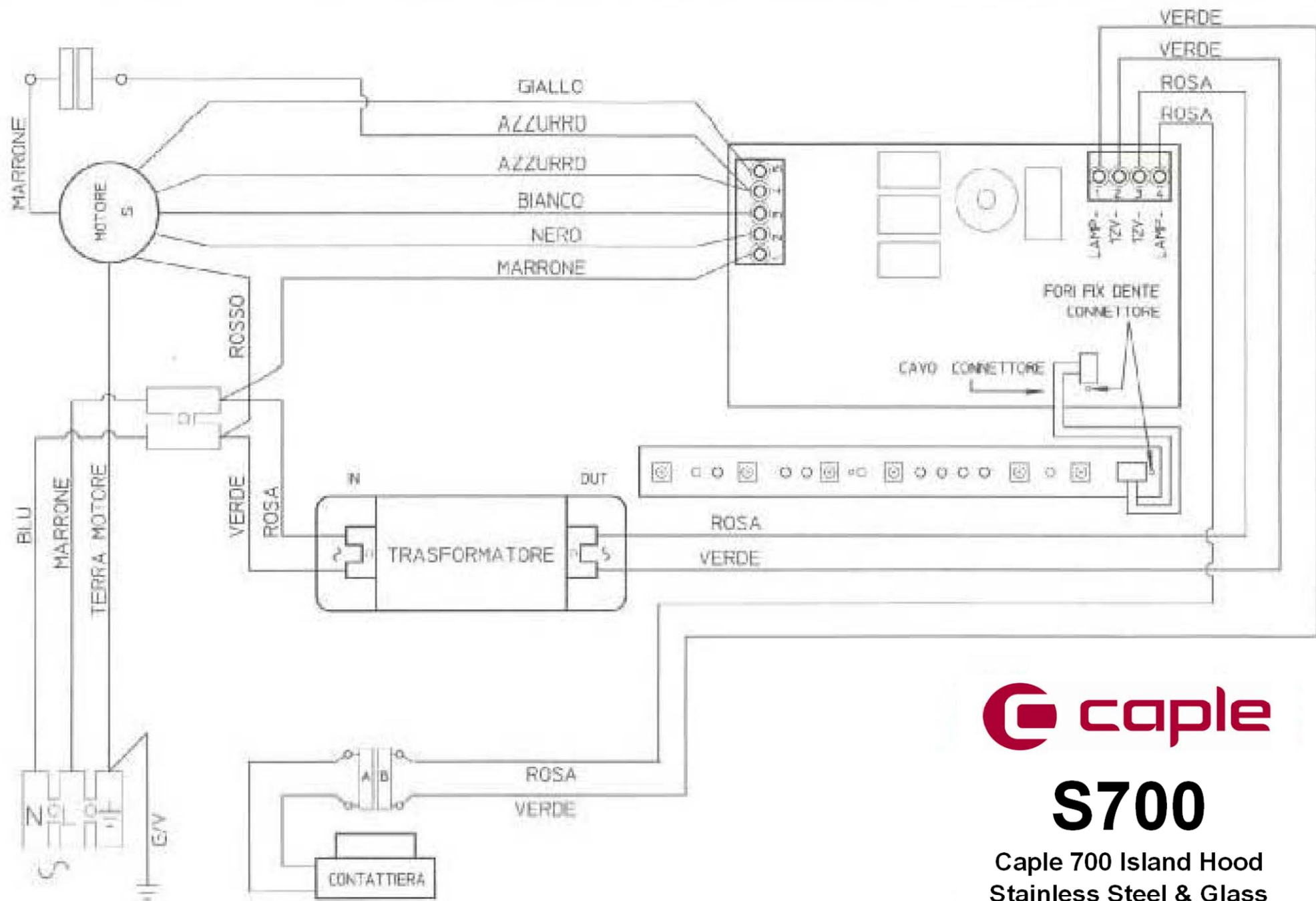

 **caple**

**S700**

Caple 700 Island Hood  
Stainless Steel & Glass