



# FGC910BK

Caple Black & Glass Hood



Technical information

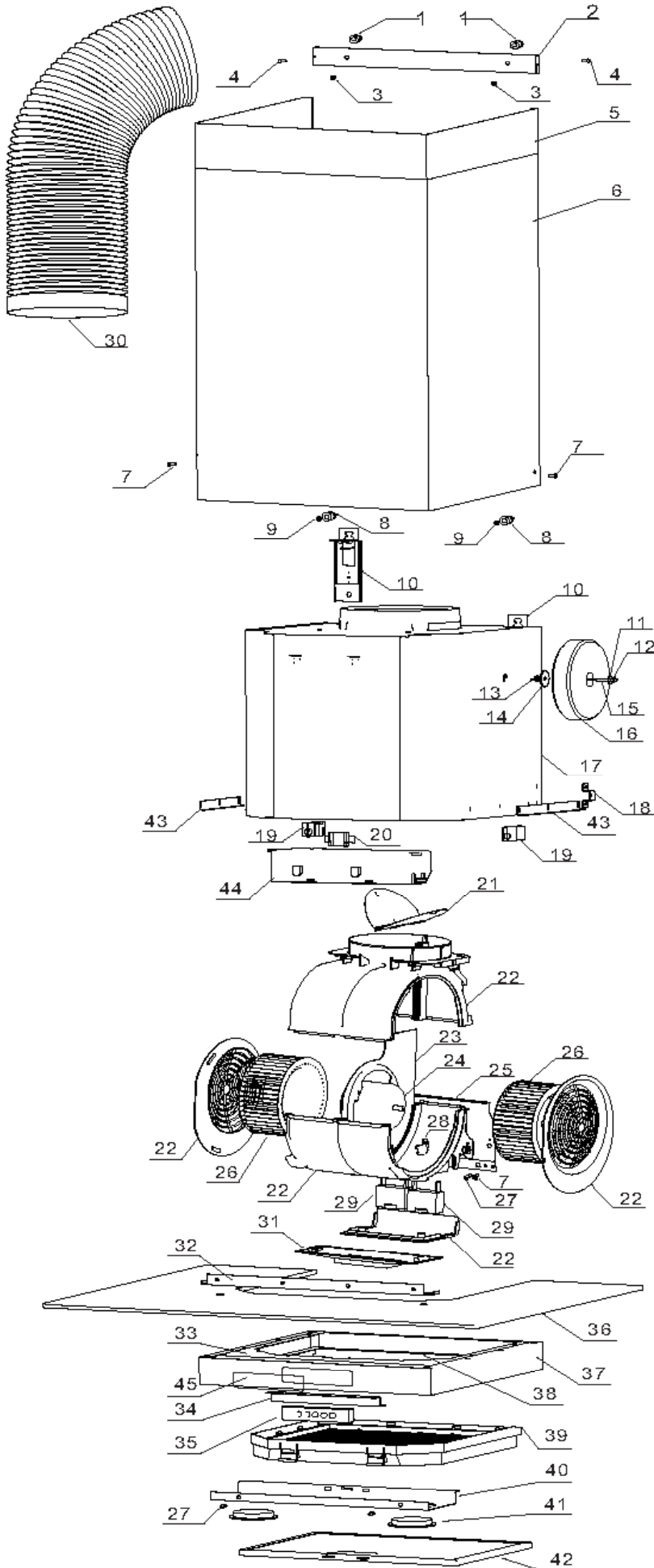

**FGC910BK**

Caple Black & Glass Hood

No.	物料编号	spare part	number
1	F-JL-6-30-A	6x30 inflatable colloidal particle	2
2	B-ZCB6000A	Support panel(upper funnel)	2
4	F-LD-3-8-BC	M3x8 stainless steel countersunk head screw	2
5	G-YCZ6000A-02-2	Upper chimney cover	1
6	G-YCZ6001A-01-2	Lower chimney cover	1
7	F-LD-4-8-BL	M4x8 B head mushroom screw	2
8	F-JL-10-45-A	10x45 inflatable colloidal particle	2
10	B-GG6000A	Leveling device assembly	2
15	F-LD-4-45-BY	M4x45 cup head screw	1
17	B-FJX6007A	Blower case	1
18	B-ZJ6001A-01	Connecting bracket(Lower funnel)	2
19	D-XJ6002A	Clip 2	2
20	D-XJ6001A	Clip 1	1
24	D-DJ6015A	Main Motor,three speeds	1
25	G-WK6004A	Blower body	1
26	D-FL6005A	Propellor	2
27	D-LD6001A	Lamp board orientation bolt	4
29	D-DR-5-450	Capacitor(5 μ F)	1
32	B-GDT6001A	Glass cover fixing bar (front)	1
33	B-LJB6000A	Blower body connecting board	1
34	B-ZJ6003A	Sensor control installing bracket	1
35	D-KZB-YJ-H819-HC4	Sensor control case(with control board)	1
36	D-BLZ6003A	Glass cover	1
38	G-CT6000A-4	Back strip	1
41	D-LED6000A	LED lamp	2
42	D-LW6000A	Aluminium filter	1
43	B-GDT6000A	Glass cover fixing bar (left/right)	2
44	D-DYB-YJ-H819Y-K2-HC	Sensor control power supply case(with electric board)	1
45	D-MB6000A	Sensor control plastic panel	1