



Instruction manual for range cooker

Model code: CR 9208



Contact Caple on 0844 800 3830 or for spare parts www.4caple.co.uk

Thank you for buying your new **Caple** cooker.

To ensure that you get the best results from your new **Caple** cooker, we strongly suggest that you read this instruction manual thoroughly before use.

This manual contains installation advice, cleaning tips and a cooking guide, as well as other important facts about your **Caple** cooker.

If treated with care, your **Caple** appliance should give you years of trouble-free cooking.

For Product Service or Spare Parts
please check contact details at:
www.caple.co.uk

Declaration of **CE** conformity

- This cooker has been designed, constructed and marketed in compliance with:
 - Safety requirements of EU Directive “Gas” 2009/142/EC;
 - Safety requirements of EU Directive “Low Voltage” 2006/95/EC;
 - Protection requirements of EU Directive “EMC” 2004/108/EC;
 - Requirements of EU Directive 93/68/EEC.
 - Requirements of EU Directive 2011/65/EU.



Important information for correct disposal of the product in accordance with EC directive 2002/96/EC.

At the end of its working life, the product must not be disposed of as urban waste. It must be taken to a special local authority differentiated waste collection centre or to a dealer providing this service.

Disposing of a household appliance separately avoids possible negative consequences for the environment and health deriving from inappropriate disposal and enables the constituent materials to be recovered to obtain significant savings in energy and resources. As a reminder of the need to dispose of household appliances separately, the product is marked with a crossed-out wheeled dustbin.

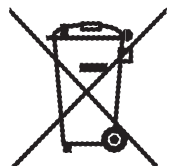

IMPORTANT SAFETY PRECAUTIONS AND RECOMMENDATIONS

IMPORTANT: This appliance is designed and manufactured solely for the cooking of domestic (household) food and is not suitable for any non domestic application and therefore should not be used in a commercial environment.

The appliance guarantee will be void if the appliance is used within a non domestic environment i.e. a semi commercial, commercial or communal environment.

Read the instructions carefully before installing and using the appliance.

- After having unpacked the appliance, check to ensure that it is not damaged and that the oven door closes correctly.
In case of doubt, do not use it and consult your supplier or a professionally qualified technician.
- Packing elements (i.e. plastic bags, polystyrene foam, nails, packing straps, etc.) should not be left around within easy reach of children, as these may cause serious injuries.
- Some appliances are supplied with a protective film on steel and aluminium parts. **This film must be removed before using the appliance.**
- **IMPORTANT:** The use of suitable protective clothing/gloves is recommended when handling or cleaning of this appliance.
- Do not attempt to modify the technical characteristics of the appliance as this may become dangerous to use. The manufacturer declines all responsibility for any inconvenience resulting from the inobservance of this condition.
- **CAUTION:** this appliance must only be installed in a permanently ventilated room in compliance with the applicable regulations.
- Do not carry out cleaning or maintenance operations on the appliance without having previously disconnected it from the electric power supply.
- **WARNING:** Ensure that the appliance is switched off before replacing the oven lamp to avoid the possibility of electric shock.
- Do not use a steam cleaner because the moisture can get into the appliance thus make it unsafe.

- Do not touch the appliance with wet or damp hands (or feet).
- Do not use the appliance whilst in bare feet.
- If you should decide not to use this appliance any longer (or decide to substitute another model), before disposing of it, it is recommended that it be made inoperative in an appropriate manner in accordance to health and environmental protection regulations, ensuring in particular that all potentially hazardous parts be made harmless, especially in relation to children who could play with unused appliances.
- The various components of the appliance are recyclable. Dispose of them in accordance with the regulations in force in your country. If the appliance is to be scrapped, remove the power cord.
- After use, ensure that the knobs are in the off position.
- Children less than 8 years of age shall be kept away unless continuously supervised.
- This appliance can be used by children aged from 8 years and above and persons with reduced physical, sensory or mental capabilities or lack of experience and knowledge if they have been given supervision or instruction concerning use of the appliance in a safe way and understand the hazards involved. Children shall not play with the appliance. Cleaning and user maintenance shall not be made by children without supervision.
- The manufacturer declines all liability for injury to persons or damage to property caused by incorrect or improper use of the appliance.
- **WARNING:** During use the appliance and its accessible parts become hot; they remain hot for some time after use.
 - Care should be taken to avoid touching heating elements (on the hob and inside the oven).
 - The door is hot, use the handle.
 - To avoid burns and scalds, young children should be kept away.
- Make sure that electrical cables connecting other appliances in the proximity of the cooker cannot come into contact with the hob or become entrapped in the oven door.
- **WARNING:** Unattended cooking on a hob with fat or oil can be dangerous and may result in fire. NEVER try to extinguish a fire with water, but switch off the appliance and then cover flame e.g. with a lid or a fire blanket.

- **WARNING:** Danger of fire: do not store items on the cooking surfaces.
- **WARNING:** When correctly installed, your product meets all safety requirements laid down for this type of product category. However special care should be taken around the rear or the underneath of the appliance as these areas are not designed or intended to be touched and may contain sharp or rough edges, that may cause injury.
- **FIRST USE OF THE OVEN** - it is advised to follow these instructions:
 - Furnish the interior of the oven as described at chapter “CLEANING AND MAINTENANCE”.
 - Switch on the empty oven on max to eliminate grease from the heating elements.
 - Disconnect the appliance from the electrical power supply, let the oven cool down and clean the interior of the oven with a cloth soaked in water and neutral detergent; then dry carefully.
- **CAUTION:** Do not use harsh abrasive cleaners or sharp metal scrapers to clean the oven door glass since they can scratch the surface, which may result in shattering of the glass.
- Do not line the oven walls with aluminium foil. Do not place baking trays or the drip tray on the base of the oven chamber.
- **FIRE RISK!** Do not store flammable material in the oven or in the storage compartment.
- Always use oven gloves when removing the shelves and food trays from the oven whilst hot.
- Do not hang towels, dishcloths or other items on the appliance or its handle – as this could be a fire hazard.
- Clean the oven regularly and do not allow fat or oils to build up in the oven base or tray. Remove spillages as soon as they occur.
- Do not stand on the cooker or on the open oven door.
- Always stand back from the appliance when opening the oven door to allow steam and hot air to escape before removing the food.
- **SAFE FOOD HANDLING:** Leave food in the oven for as short a time as possible before and after cooking. This is to avoid contamination by organisms which may cause food poisoning. Take particular care during warmer weather.
- **WARNING:** Taking care NOT to lift the cooker by the door handle.

1 - Electrical Requirements

WARNING!
ELECTRICITY CAN BE EXTREMELY DANGEROUS.
THIS APPLIANCE MUST BE EARTHED.

For your safety please read the following information:

This appliance must be installed by a qualified technician according with the current local regulations and in compliance with the manufacturer instructions.

The appliance must be connected to the electrical network verifying above all that the voltage corresponds to the value indicated on the specifications plate and that the cables section of the electrical plant can bear the load which is also indicated on the plate.

The cooker must be connected directly to the mains placing an omnipolar switch with minimum opening between the contacts of 3 mm between the appliance and the mains.

The power supply cable must not touch the hot parts and must be positioned so that it does not exceed 75°C at any point.

Once the cooker has been installed, the switch must always be accessible.

Before effecting any intervention on the electrical parts the appliance must be disconnected from the network.

IMPORTANT: This cooker must be connected to a suitable double pole control unit adjacent to the cooker.

NO DIVERSITY CAN BE APPLIED TO THIS CONTROL UNIT.

Electrical Installation - Wall box connection

This appliance must be connected to a double pole isolating switch (fig. 1.1) and to the terminal block in the cooker (figs. 1.2, & 1.3) using the following guide:

- 1) The wire which is coloured brown must be connected to the terminal marked **L** (Live), or coloured Red.
- 2) The wire which is coloured blue must be connected to the terminal marked **N** (Neutral), or coloured Black.
- 3) The wire which is coloured green and yellow must be connected to the terminal marked **E** (Earth) \perp or coloured Green.

IMPORTANT: These connections must be carried out by a qualified electrical engineer.

Electrical feeder cable connection

To connect the feeder cable to the cooker it is necessary to:

- Remove the screw that hold shield “**A**” behind the cooker (fig. 1.2).
- Insert the feeder cable of the suitable section (as described in the next chapter) into the cable clamp “**D**”.
- Connect the phase and earth cables to the terminal block “**B**” according to the diagram in figure 1.3.
- Pull the feeder cable and block it with cable clamp “**D**”.
- Re-mount shield “**A**”.

N.B. The earth conductor must be left about 3 cm longer than the others.

FEEDER CABLE SECTION type H05RR-F

230 V \sim 3 x 2,5 mm² (**)

(**) – Connection with wall box connection.

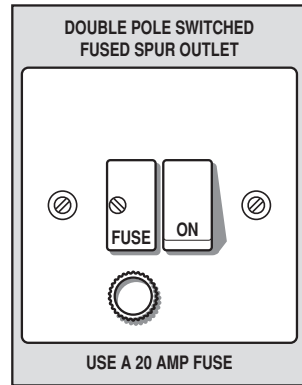

Fig. 1.1

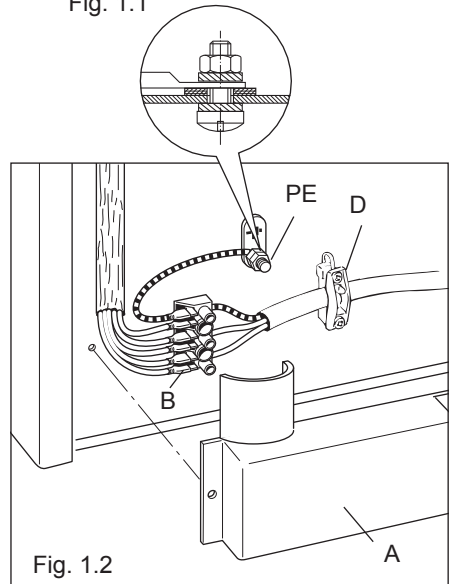

Fig. 1.2

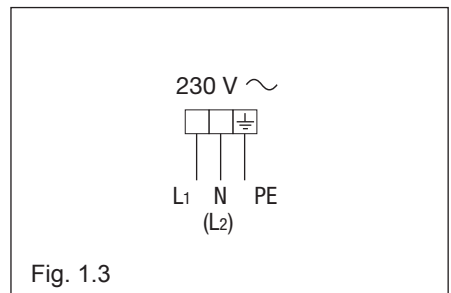

Fig. 1.3

FOR THE INSTALLER

2 - Location

This cooker has class “2/1” overheating protection so that it can be installed next to a cabinet.

The cooker must be installed by a qualified technician and in compliance with local safety standards.

The appliance may be installed in a kitchen, kitchen/diner or a bed sitting room, but not in a room or space containing a bath or a shower.

The appliance must not be installed in a bed-sitting room of less than 20 m³.

The appliance is designed and approved for domestic use only and should not be installed in a commercial, semi commercial or communal environment.

Your product will not be guaranteed if installed in any of the above environments and could affect any third party or public liability insurances you may have.

If the cooker is installed adjacent to furniture which is higher than the gas hob cooktop, a gap of at least 200 mm must be left between the side of the cooker and the furniture.

The furniture walls adjacent to the cooker must be made of material resistant to heat.

The veneered synthetic material and the glue used must be resistant to a temperature of 90°C in order to avoid ungluing or deformations.

Curtains must not be fitted immediately behind appliance or within 500 mm of the sides. It is essential that the cooker is positioned as stated in fig. 2.1.

If the cooker is located on a pedestal it is necessary to provide safety measures to prevent falling out.

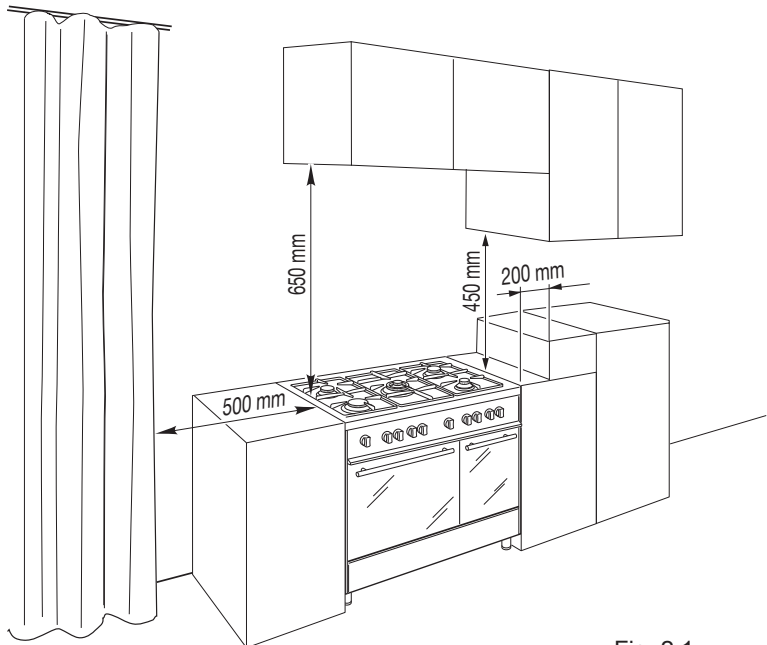
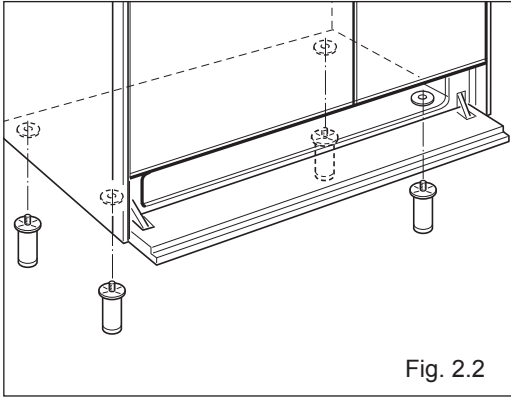

Fig. 2.1



Fitting the adjustable feet

The adjustable feet must be fitted to the base of the cooker before use.

Rest the rear of the cooker on a piece of the polystyrene packaging exposing the base for the fitting of the feet.

Fit the 4 legs by screwing them tight into the support base as shown in picture 2.3.

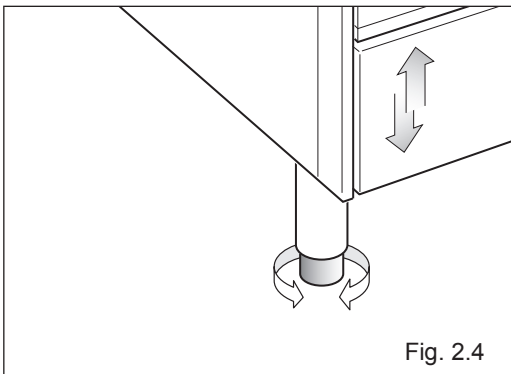
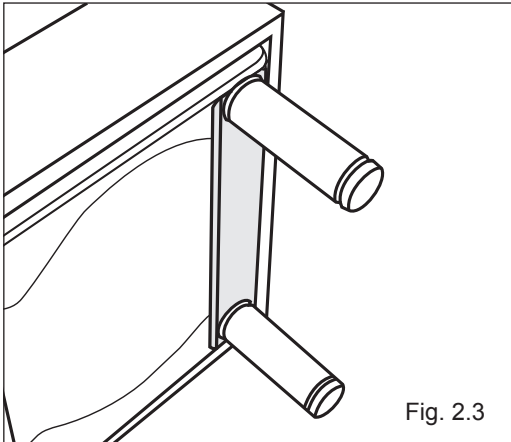

Levelling the cooker

The cooker may be levelled by screwing the lower ends of the feet IN or OUT (fig. 2.4).

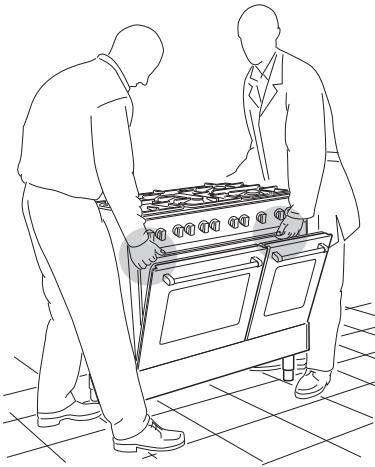

Fig. 2.5

WARNING

When raising cooker to upright position always ensure two people carry out this manoeuvre to prevent damage to the adjustable feet (fig. 2.5).

WARNING

Be careful: do not lift the cooker by the door handle when raising to the upright position (fig. 2.6).

WARNING

When moving cooker to its final position **DO NOT DRAG** (fig. 2.7). Lift feet clear of floor (fig. 2.5).

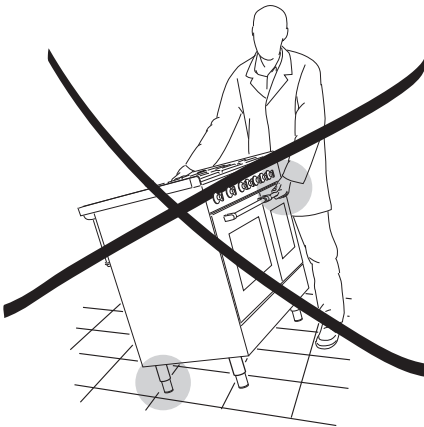

Fig. 2.6



10 Fig. 2.7

Anti-tilt Bracket

Important!

To restrain the appliance and prevent it tipping accidentally, fit a bracket to its rear to fix it securely to the wall.

To fit the anti-tilt bracket:

1. After you have located where the cooker is to be positioned, mark on the wall the place where the two screws of the anti-tilt bracket have to be fitted.
Please follow the indications given in fig. 2.8.
2. Drill two 8 mm diameter holes in the wall and insert the plastic plugs supplied.

Important!

Before drilling the holes, check that you will not damage any pipes or electrical wires.

3. Loosely attach the anti-tilt bracket with the two screws supplied.
4. Move the cooker to the wall and adjust the height of the anti-tilt bracket so that it can engage in the slot on the cooker's back, as shown in fig. 2.8.
5. Tighten the screws attaching the anti-tilt bracket.
6. Push the cooker against the wall so that the anti-tilt bracket is fully inserted in the slot on the cooker's back.

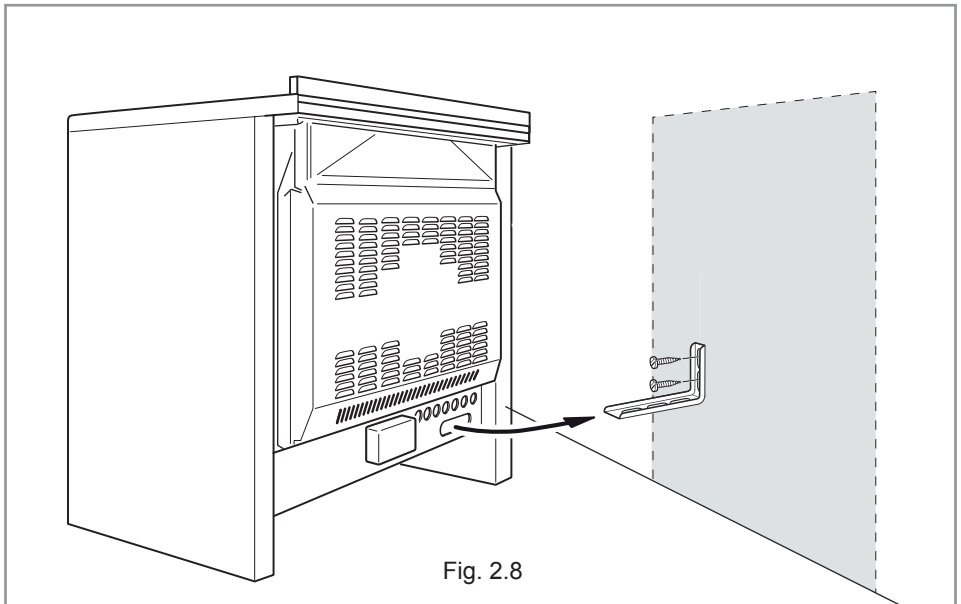

Fig. 2.8

Provision for ventilation

- The appliance should be installed into a room or space with an air supply in accordance with BS 5440-2: 2000.
- For rooms with a volume of less than 5 m³ - permanent ventilation of 100 cm² free area will be required.
- For rooms with a volume of between 5 m³ and 10 m³ a permanent ventilation of 50 cm² free area will be required unless the room has a door which opens directly to the outside air in which case no permanent ventilation is required.
- For rooms with a volume greater than 10 m³ - no permanent ventilation is required.
- **NB. Regardless of room size, all rooms containing the appliance must have direct access to the outside air via an openable window or equivalent.**
- Where there are other fuel burning appliances in the same room, BS 5440-2: 2000 should be consulted to determine the correct amount of free area ventilation requirements.
- The above requirements allow also for use of a gas oven and grill but if there are other gas burning appliances in the same room, consult a qualified engineer.

3 - Gas installation

IMPORTANT NOTE

This appliance is supplied for use on NATURAL GAS or LPG (check the gas regulation label attached on the appliance).

- Appliances supplied for use on NATURAL GAS: they are adjusted for this gas only and cannot be used on any other gas (LPG) without modification. The appliances are manufactured for conversion to LPG.
- Appliances supplied for use on LPG: they are adjusted for this gas only and cannot be used on any other gas (NATURAL GAS) without modification. The appliances are manufactured for conversion to NATURAL GAS.

If the NATURAL GAS/LPG conversion kit is not supplied with the appliance this kit can be purchased by contacting the After-Sales Service.

Installation & service regulations (United Kingdom)

It is a legal requirement that all gas appliances are Installed & Serviced by a competent person in accordance with the current editions of the following Standards & Regulations or those regulations appropriate to the geographical region in which they are to be installed:

- Gas Safety (Installation & Use) Regulations
- Building Regulations
- British Standards
- Regulations for Electrical Installation

Installation and service of any gas product must be made by a suitably qualified person competent on the type of product being installed or serviced and holding a valid certificate of competence for the work being carried out. Currently the proof of competence is the Accredited Certification Scheme (ACS) or S/NVQ that has been aligned to the ACS.

It is also a requirement that all businesses or self employed installers are members of a class of person approved by the Health and Safety Executive.

Failure to install the appliance correctly could invalidate any manufacturers warranty and lead to prosecution under the above quoted regulation.

Gas connection

The installation of the gas appliance to Natural Gas or LP Gas must be carried out by a suitably qualified and registered person. Installers shall take due account of the provisions of the relevant British Standards Code of Practice, the Gas Safety Regulations and the Building Standards (Scotland)(Consolidation) Regulations issued by the Scottish Development Department.

Installation to Natural Gas

Installation to Natural Gas must conform to the Code of Practice, etc.

The supply pressure for Natural Gas is 20 mbar.

The installation must conform to the relevant British Standards.

Installation to LP Gas

When operating on Butane gas a supply pressure of 28-30 mbar is required. When using Propane gas a supply pressure of 37 mbar is required.

The installation must conform to the relevant British Standards.

Warning: Only a suitably qualified and registered person, also with technical knowledge of electricity should install the appliance. He should observe the Regulations and Codes of Practice governing such installation of gas appliances.

Note: It is recommended that the gas connection to the appliance is installed with a flexible connecting tube made to BS5386.

Notes:

- **Flexible hoses can be used where the sited ambient temperature of the hose does not exceed 70°C. These hoses must be manufactured in accordance with BS669 part 1 and be of the correct construction for the type of gas being used.**
- **Gas hoses designed for natural gas MUST NOT be used for supplying LPG gas (LPG gas hoses can be identified by a either a red band or stripe on the rubber outer coating of the hose).
The hose should not be crushed or trapped or be in contact with sharp or abrasive edges.**

Using a suitable leak detection fluid solution (e.g. Rocol) check each gas connection one at a time by brushing the solution over the connection.

The presence of bubbles will indicate a leak.

If there is a leak, tighten the fitting and then recheck for leaks.

IMPORTANT!

Do not use a naked flame to test for leaks.

Gas connection **GB** Cat: II 2H3+

The gas supply must use the nearest gas inlet pipe which is located at the left or the right hand side at the rear of the appliance (figs. 3.1, 3.3).
The hose should also be connected in such way that it does not touch the floor.
To screw the connecting tube operate with two spanners (fig. 3.2).
The unused end inlet pipe must be closed with the plug interposing the gasket.

After connecting to the mains, check that the coupling are correctly sealed, using soapy solution, but never a flame.

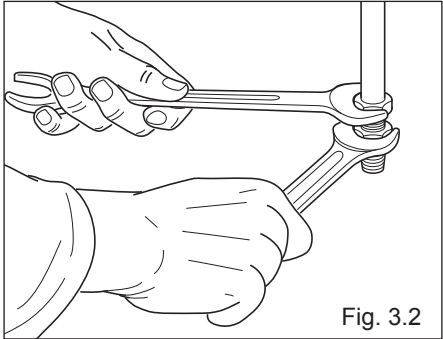

Fig. 3.2

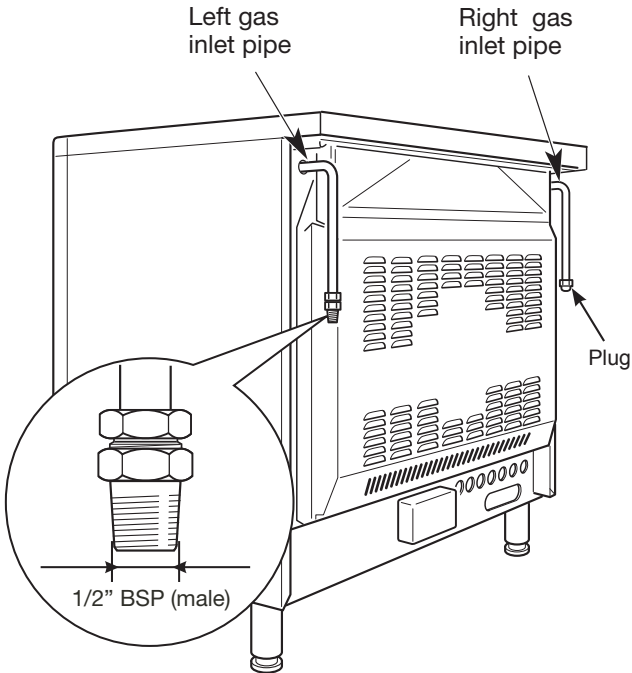

Fig. 3.1

Important prescriptions for gas connection

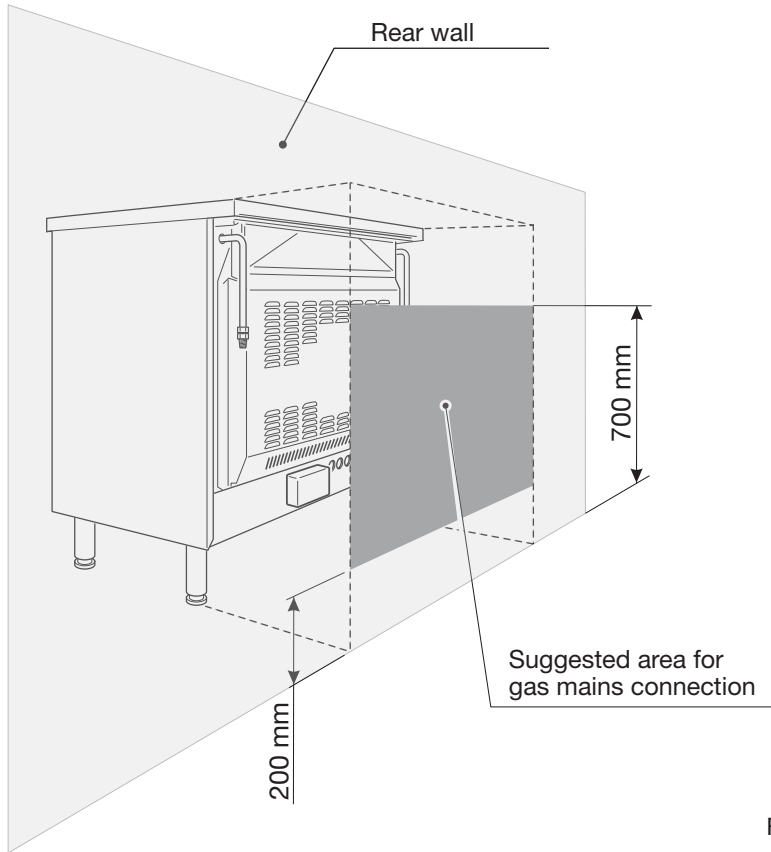

Fig. 3.3

Conversion to Natural Gas or to LPG

Injectors replacement of top burners

Every cooker is provided with a set of injectors for the various types of gas.

Injectors not supplied can be obtained from the After-Sales Service.

Select the injectors to be replaced according to the table at page 18.

The nozzle diameters, expressed in hundredths of a millimetre, are marked on the body of each injector.

To replace the injectors proceed as follows:

- Remove the grids and extract the burner bodies.
- Using a wrench, substitute the nozzle injectors “J” (Figs. 3.4, 3.5) with those most suitable for the kind of gas for which it is to be used (see “Table for the choice of the injectors”).

The burners are constructed in such a way so as not to require the regulation of the primary air.

Adjusting the minimum of the top burners

In the minimum position the flame must have a length of about 4 mm and must remain lit even with a quick turn from the maximum position to that of minimum.

The flame adjustment is done in the following way:

- Turn on the burner
- Turn the tap to the MINIMUM position
- Take off the knob
- With a thin screwdriver turn the screw “F” until adjustment is correct (fig. 3.6).

Normally for LPG, the regulation screw is tightened up.

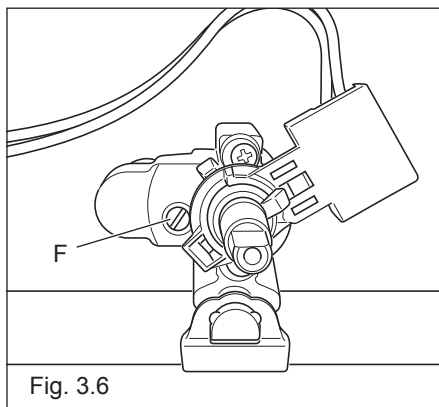
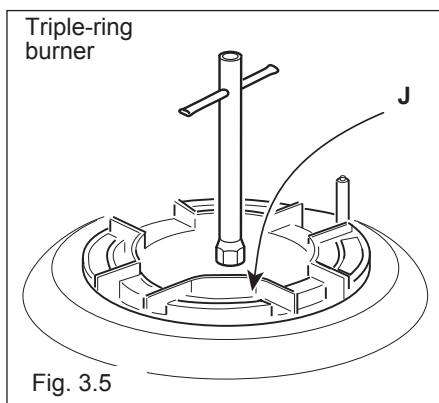
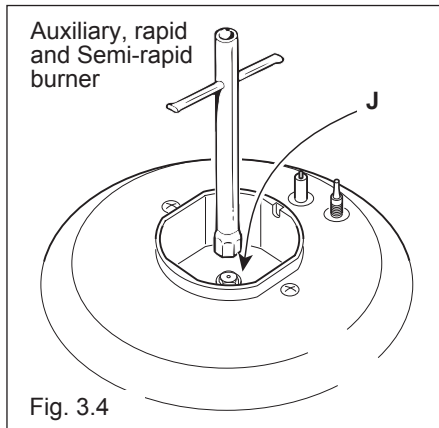



TABLE FOR THE CHOICE OF THE INJECTORS

 Cat: II 2H 3+			G30 28-30 mbar G31 37 mbar	G 20 20 mbar
BURNERS	Nominal Power [Hs - kW]	Reduced Power [Hs - kW]	Ø injector [1/100 mm]	Ø injector [1/100 mm]
Auxiliary (A)	1,00	0,30	50	72 (X)
Semi-rapid (SR)	1,75	0,45	65	97 (Z)
Rapid (R)	3,00	0,75	85	115 (Y)
Triple ring (TR)	3,50	1,50	95	135 (T)

AIR VENT NECESSARY FOR GAS COMBUSTION = (2 m ³ /h x kW)	
BURNERS	Air necessary for combustion [m ³ /h]
Auxiliary (A)	2,00
Semi-rapid (SR)	3,50
Rapid (R)	6,00
Triple ring (TR)	7,00

Lubrication of the gas taps

If the gas tap becomes stiff, it is necessary to dismount it accurately clean it with gasoline and spread a bit of special grease resistant to high temperatures on it.

The operations must be executed by a qualified technician.

IMPORTANT

All interventions regarding installation maintenance and conversion of the appliance must be fulfilled with original factory parts.

The manufacturer declines any liability resulting from the non-compliance of this obligation.

4 - Features and Technical Data

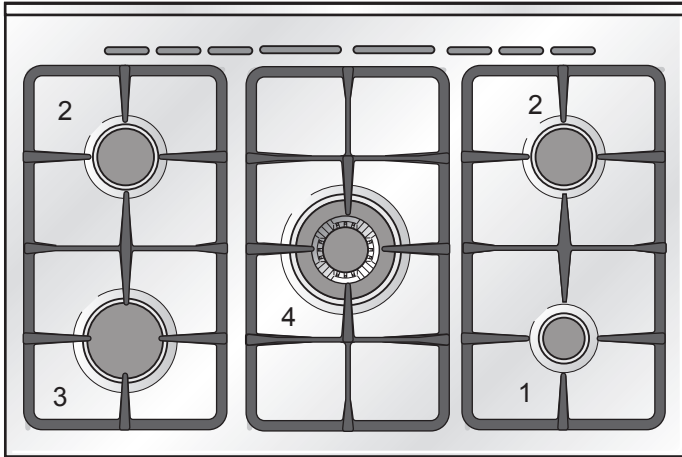

Fig. 4.1

Cooking hob - (Fig. 4.1)

1. Auxiliary burner (A)	1,00 kW
2. Semi-rapid burner (SR)	1,75 kW
3. Rapid burner (R)	3,00 kW
4. Triple-ring burner (TR)	3,50 kW

Important Note:

The electric ignition is incorporated in the knobs.

The appliance has a safety valve system fitted, the flow of gas will be stopped if and when the flame should accidentally go out.

Control Panel

Fig. 4.2

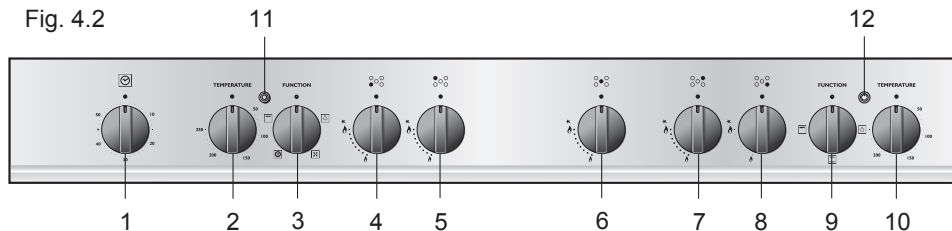

Control panel - Controls description - (Fig. 4.2)

1. Minute counter (60 minutes)
2. Fan main oven thermostat knob (left oven)
3. Fan main oven switch knob (left oven)
4. Front left burner control knob
5. Rear left burner control knob
6. Central burner control knob
7. Rear right burner control knob
8. Front right burner control knob
9. Conventional oven switch knob (right oven)
10. Conventional oven thermostat knob (right oven)

Pilot lamps:

11. Main oven thermostat indicator light (left oven)
12. Conventional oven thermostat indicator light (right oven)



Please note: This appliance incorporates a safety cooling fan which you will hear operating whenever the oven or grill are in use. This fan may continue to run for several minutes after the appliance has been switched off.

This fan is to reduce the external temperature of the appliance and cool the internal components.

How To Use the Hob Burners

Hob burners

Each hob burner is controlled by a separate gas tap operated by a control knob (fig. 4.3) which has 3 positions marked on the control panel, these are:

- Symbol ● : tap closed (burner off)
- Symbol  : High (maximum)
- Symbol  : Low (minimum)

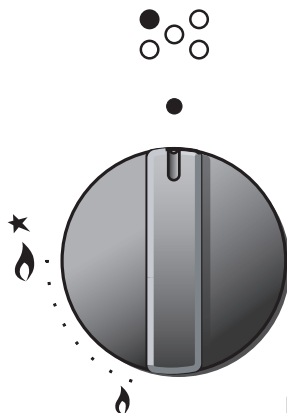



Fig. 4.3

- The maximum setting permits rapid boiling of liquids, whereas the minimum setting allows slower warming of food or maintaining simmering conditions of liquids.
- To reduce the gas flow to minimum, rotate the knob anti-clockwise to point the indicator towards the small flame symbol.
- Other intermediate operating can be achieved by positioning the control knob indicator between the maximum and minimum setting, but not between the maximum and off positions.

N.B. When the cooker is not being used, set the gas knobs to their closed positions and also close the cock valve on the gas bottle or the main gas supply line.

Lighting of the hob burners

To ignite the burner, the following instructions are to be followed:

- 1) Press in the corresponding knob and turn counter-clockwise to the full flame position marked by the  symbol (fig. 4.3) and hold the knob in until the flame has been lit.
In the case of a mains failure light the burner with a match or lighted taper.
- 2) Wait for about ten seconds after the gas burner has been lit before letting go of the knob (valve activation delay).
- 3) Adjust the gas valve to the desired position.

Important:

If the burner flame should go out for some reason, the safety valve will automatically stop the gas flow.

To re-light the burner, return the knob to the closed “●” position, **wait for at least 1 minute** and then repeat the lighting procedure.

If your local gas supply makes it difficult to light the burner with the knob set to maximum, set the knob to minimum and repeat the operation.

Choice of burner

The burner must be chosen according to the diameter of the pans and energy required.

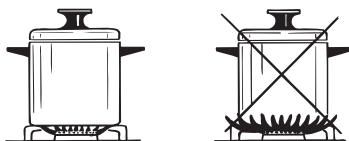

Fig. 4.4

Burners	Pan diameter
Auxiliary	12 ÷ 14 cm
Semi-rapid	16 ÷ 24 cm
Rapid	24 ÷ 26 cm
Triple-ring	26 ÷ 28 cm

do not use pans with concave or convex bases

Saucepans with handles which are excessively heavy, in relationship to the weight of the pan, are safer as they are less likely to tip.

Pans which are positioned centrally on burners are more stable than those which are offset.

It is far safer to position the pan handles in such a way that they cannot be accidentally knocked.

When deep fat frying fill the pan only one third full of oil.

DO NOT cover the pan with a lid and **DO NOT** leave the pan unattended.

In the unfortunate event of a fire, leave the pan where it is and turn off all controls.

Place a damp cloth or correct fitting lid over the pan to smother the flames.

DO NOT use water on the fire.

Leave the pan to cool for at least 30 minutes.

Caution!

The cooking hob becomes very hot during operation.

Keep children well out of reach.

5 - Minute counter

The minute counter is a timed acoustic warning device which can be set for a maximum of 60 minutes.

The knob (Fig. 5.1) must be rotated clockwise as far as the 60 minute position and then set to the required time by rotating it anticlockwise.

IMPORTANT WARNING: This is only a mechanical timer.

Remember to turn off the oven/grill manually.

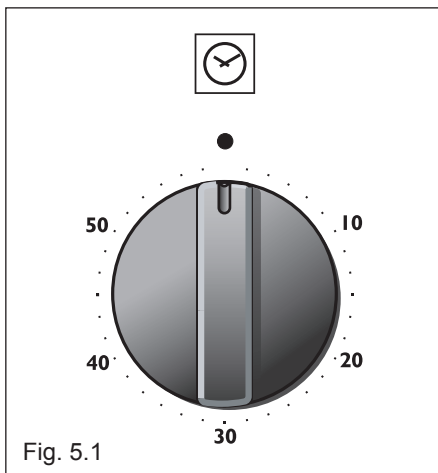

6 - Fan electric main oven (left oven)

Attention: the oven door becomes very hot during operation. Keep children away.



General features

With your new Fan oven it is possible to cook a variety of food using the 2 different cooking functions.

The 2 positions, thermostatically controlled, are obtained by 2 heating elements.

- Grill element 2000 W
- Circular element 2200 W

Note:

Upon first use, it is advisable to operate the oven at the maximum temperature (thermostat knob on position 250) for 60 minutes in the position  and for another 15 minutes in the  mode in order to eliminate any traces of grease from the electrical resistances.

Operating principles

Heating and cooking in the **FAN** oven are obtained in the following ways:

a. by forced convection

A fan sucks in the air contained in the oven muffle, which sends it through the circular heating element and then sends it back through the muffle.

Before the hot air is sucked back again by the fan to repeat the described cycle, it envelops the food in the oven, provoking a complete and rapid cooking.

It is possible to cook several dishes simultaneously.

b. by radiation

The heat is radiated by the infra red grill element.

c. by ventilation

The food is defrosted by using the fan only function without heat.

WARNING:

The door is hot, use the handle.

During use the appliance becomes hot. Care should be taken to avoid touching heating elements inside the oven.

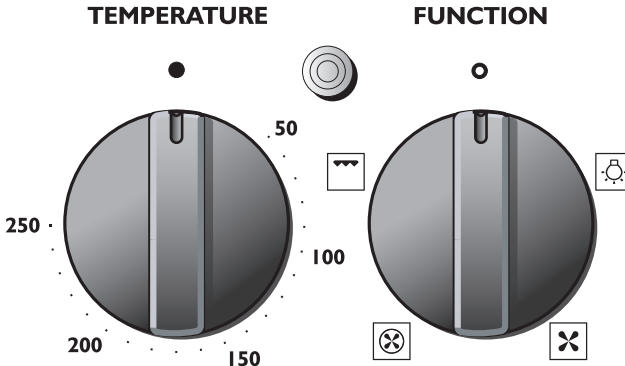

Fig. 6.1

Fig. 6.2

Thermostat knob (fig. 6.1)

This only sets the cooking temperature and does not switch the oven on. Rotate clockwise until the required temperature is reached (**from 50 to 250°C**).

The oven thermostat indicator light will illuminate when the oven is switched on and turns off when the oven reaches the correct temperature.

The light will cycle on and off during cooking.

Function selector knob (fig. 6.2)

Rotate the knob clockwise to set the oven for one of the following functions:



Oven light

By setting the knob to this position, only the oven light comes on. It remains on in all the cooking modes.



Defrosting frozen foods

Only the oven fan is on.

To be used with the thermostat knob on “●” because the other positions have no effect. The defrosting is done by simple ventilation without heat.

Recommended for:

To rapidly defrost frozen foods; 1 kilogram requires about one hour.

The defrosting times vary according to the quantity and type of foods to be defrosted.



Hot air cooking

The circular element and the fan are on.

The heat is diffused by forced convection and the temperature must be regulated between 50° and 250 °C with the thermostat knob.

It is not necessary to preheat the oven.

Recommended for:

For foods that must be well done on the outside and tender or rare on the inside, i. e. lasagna, lamb, roast beef, whole fish, etc.



Grilling

The infrared grill element comes on. The heat is dispersed by radiation. Set the thermostat knob to between 50° and 200°C.

Always grill with the oven door closed.

For cooking hints, see the chapter “USE OF THE GRILL”.

Recommended for:

Intense grilling, browning, cooking au gratin and toasting etc.

Do not grill for longer than 30 minutes at any one time on full heat (200°C).

Caution: the oven door becomes very hot during operation.

Keep children well out of reach.

Cooking Advice

Sterilization

Sterilization of foods to be conserved, in full and hermetically sealed jars, is done in the following way:

- a. Set the switch to position .
- b. Set the thermostat knob to position 185 °C and preheat the oven.
- c. Fill the dripping pan with hot water.
- d. Set the jars onto the dripping pan making sure they do not touch each other and the door and set the thermostat knob to position 135 °C.

When sterilization has begun, that is, when the contents of the jars start to bubble, turn off the oven and let cool.

Regeneration

Set the switch to position  and the thermostat knob to position 150° C. Bread becomes fragrant again if wet with a few drops of water and put into the oven for about 10 minutes at the highest temperature.

Roasting

To obtain classical roasting, it is necessary to remember:

- that it is advisable to maintain a temperature between 180 and 200 °C.
- that the cooking time depends on the quantity and the type of foods.

Simultaneous cooking of different foods

The  consists a simultaneous heterogeneous cooking of different foods. Different foods such as fish, cake and meat can be cooked together without mixing the smells and flavours together. This is possible since the fats and vapours are oxidized while passing through the electrical element and therefore are not deposited onto the foods.

The only precaution to follow are:

- The cooking temperatures of the different foods must be as close to as possible, with a maximum difference of 20° - 25 °C.
- The introduction of the different dishes in the oven must be done at different times in relation to the cooking times of each one.

The time and energy saved with this type of cooking is obvious.

Use of the grill

Preheat the oven for about 5 minutes.

Introduce the food to be cooked, positioning the rack as close to the grill as possible. The drip pan should be placed under the rack to catch the cooking juices and fats.

Grilling with the oven door closed.

Do not grill for longer than 30 minutes at any one time.

**Caution: the oven door becomes very hot during operation.
Keep children well out of reach.**

Oven cooking

Before introducing the food, preheat the oven to the desired temperature. For a correct preheating operation, it is advisable to remove the tray from the oven and introduce it together with the food, when the oven has reached the desired temperature. Check the cooking time and turn off the oven 5 minutes before the theoretical time to recuperate the stored heat.

7 - Conventional oven (right oven)



General features

As its name indicates, this is an oven that presents particular features from an operational point of view.

The conventional oven is provided with 3 heating elements which are:

- Top element 643 W
- Bottom element 735 W
- Grill element 1332 W

NOTE:

Upon first use, it is advisable to operate the oven at the maximum temperature (thermostat knob on position 250) for 60 minutes in the position  and for another 15 minutes in the position  to eliminate possible traces of grease on the heating elements.

Operating principles

Heating and cooking in the CONVENTIONAL oven are obtained in the following ways:

a. by natural convection

The heat is produced by the upper and lower heating elements.

b. by radiation

The heat is radiated by the infra red grill element.

WARNING:

The door is hot, use the handle.

During use the appliance becomes hot. Care should be taken to avoid touching heating elements inside the oven.

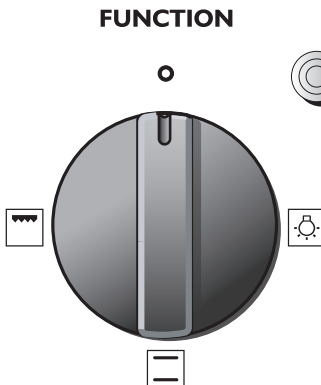

Fig. 7.1

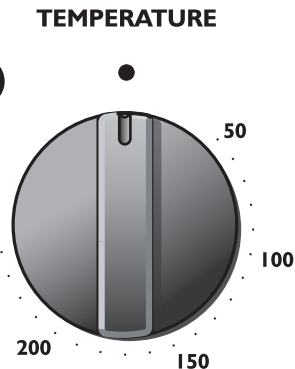

Fig. 7.2

Thermostat knob (fig. 7.2)

This only sets the cooking temperature and does not switch the oven on. Rotate clockwise until the required temperature is reached (**from 50 to 250°C**).

The oven thermostat indicator light will illuminate when the oven is switched on and turns off when the oven reaches the correct temperature.

The light will cycle on and off during cooking.

Function selector knob (fig. 7.1)

Rotate the knob clockwise to set the oven for one of the following functions.



Oven light

By setting the knob to this position, only the oven light comes on. It remains on in all the cooking modes.



Traditional convection cooking

This function can also be used for traditional convection cooking: the temperature knob must be regulated between 50 and 250°C. It is necessary to preheat the oven before introducing the foods to be cooked.

Traditional convection cooking recommended use:

For foods which require the same cooking temperature both internally and externally, i.e. roasts, spare ribs, meringue, etc.



Traditional Grilling

The infrared grill element comes on. The heat is dispersed by radiation. Set the thermostat knob to between 50° and 200°C.

Always grill with the oven door closed.

For cooking hints, see the chapter "USE OF THE GRILL".

Recommended for:

Intense grilling, browning, cooking au gratin and toasting etc.

Do not grill for longer than 30 minutes at any one time on full heat (200°C).

Caution: the oven door becomes very hot during operation.

Keep children well out of reach.

Use of the grill

Preheat the oven for about 5 minutes.

Introduce the food to be cooked, positioning the rack as close to the grill as possible. The drip pan should be placed under the rack to catch the cooking juices and fats.

Grill with the oven door closed.

Do not grill for longer than 30 minutes at any one time on full heat (200°C).

Caution: the oven door becomes very hot during operation. Keep children well out of reach.

Oven cooking

Before introducing the food, preheat the oven to the desired temperature.

For a correct preheating operation, it is advisable to remove the tray from the oven and introduce it together with the food, when the oven has reached the desired temperature. Check the cooking time and turn off the oven 5 minutes before the theoretical time to recuperate the stored heat.

Recommended cooking temperature

Food	°C	°F	Gas Mark	Shelf Position*	Cooking Time (approx)
CAKES					
Victoria sandwich	190	375	5	2 or 3	20-25 mins
Small cakes/buns	190	375	5	1 and 2	15-20 mins
Maidera cake	180	350	4	2 or 3	20 mins
Fruit cake	170	325	3	3	1¼ hours
Rich fruit cake	150	300	2	3 or 4	2½ hours
Scones	225	425	8-9	2	8-10 mins
PASTRY					
Puff	225	425	8-9	2	10-20 mins
Short crust	200	400	6	2	20-30 mins
Plate tarts	200-210	400-410	6	1 or 2	30-35 mins
Quiches and flans	200-210	400-410	6	1 or 2	40-45 mins
YEAST					
Bread loaf	225	425	7-8	2	35-55 mins
Bread rolls	220	425	7	1 or 2	15-20 mins
Pizza dough	230	450	8	2	20 mins
ROAST MEAT					
Beef – Medium	190	375	5	2 or 3	20 mins/lb + 20 mins
Lamb	190	375	5	2 or 3	25-30 mins/b + 25 mins
Pork	190-200	375-400	5-7	2 or 3	30 mins/lb + 30 mins
Veal	190	375	5	2 or 3	30 mins/b + 30 mins
Chicken	190	375	5	2 or 3	30 mins/b + 30 mins
Turkey up to 10lb	180	350	4	2 or 3	18-20 mins/b + 20 mins
Stews/casseroles	150-170	300-325	2-3	2 or 3	1½ 2 hours

N.B. For fan ovens reduce the temperature by 10-20°C. For any dish taking one hour or over to cook, reduce the cooking time by 10 minutes per hour.

* Shelf positions have been counted from the top of the oven to the base. A fan oven creates more even temperature throughout, therefore the shelf positions are not as critical.

8 - Cleaning and Maintenance

General advice

- When the appliance is not being used, it is advisable to keep the gas tap closed.
- Every now and then check to make sure that the flexible tube that connects the gas line or the gas cylinder to the appliance is in perfect condition and eventually substitute it if it shows signs of wearing or damage.
- The periodical lubrication of the gas taps must be done only by specialized personnel.
- If a tap becomes stiff, do not force; contact your local Service Centre.
- Do not use cleaning products with a chlorine or acidic base.
- **Important:**
the use of suitable protective clothing/gloves is recommended when handling or cleaning of this appliance.

WARNING

When correctly installed, your product meets all safety requirements laid down for this type of product category. However special care should be taken around the rear or the underneath of the appliance as these areas are not designed or intended to be touched and may contain sharp or rough edges, that may cause injury.

IMPORTANT

Before any operation of cleaning and maintenance disconnect the appliance from the electrical network.

Attention

The appliance gets very hot, mainly around the cooking areas. It is very important that children are not left alone in the kitchen when you are cooking.

Do not use a steam cleaner because the moisture can get into the appliance thus make it unsafe.

Enamelled parts

All the enamelled parts must be cleaned with a sponge and soapy water or other non-abrasive products.

Dry preferably with a microfibre or soft cloth.

Acidic substances like lemon juice, tomato sauce, vinegar etc. can damage the enamel if left too long.

Stainless steel, aluminium parts and silk-screen printed surfaces

Clean using an appropriate product. Always dry thoroughly.

IMPORTANT: these parts must be cleaned very carefully to avoid scratching and abrasion. You are advised to use a soft cloth and neutral soap.

CAUTION: Do not use abrasive substances or non-neutral detergents as these will irreparably damage the surface.

Replacing the oven light bulb

Switch the cooker off at the mains.

When the oven is cool unscrew and replace the bulb with another one resistant to high temperatures (300°C), voltage 230 V (50 Hz), E14 and same power (check watt power as stamped in the bulb itself) of the replaced bulb.

Note: Oven bulb replacement is not covered by your guarantee.

Gas tap

If a tap becomes stiff, do not force; contact your local Service Centre.

Flexible tube

From time to time, check the flexible tube connecting the gas supply to the cooker.

It must be always in perfect condition; in case of damage arrange for it to be replaced by a suitably qualified and registered person.

Burners

They can be removed and washed with soapy water only.

They will remain always perfect if cleaned with products used for silverware.

After cleaning or wash, check that burner-caps and burner-heads are dry before placing them in the **respective housings**.

Note: To avoid damage to the electric ignition do not use it when the burners are not in place.

Correct replacement of the burners

It is very important to check that the burner flame distributor “F” and the cap “C” has been correctly positioned (see fig. 8.1-8.2) - failure to do so can cause a poor burner flame and/or damage to the burner and hob.

Check that the electrode “S” (figs. 8.1, 8.3) is always clean to ensure trouble-free sparking.

Check that the probe “T” (figs. 8.1, 8.3) next to each burner is always clean to ensure correct operation of the safety valves.

Both the probe and ignition plug must be very carefully cleaned.

The burners become very hot during operation.

Keep children away.

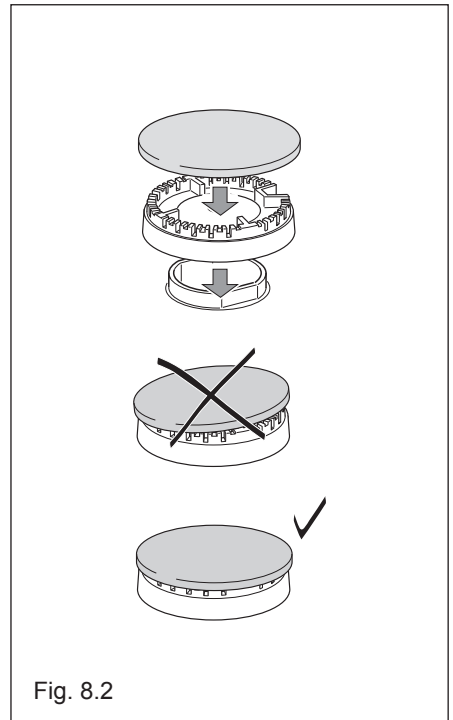
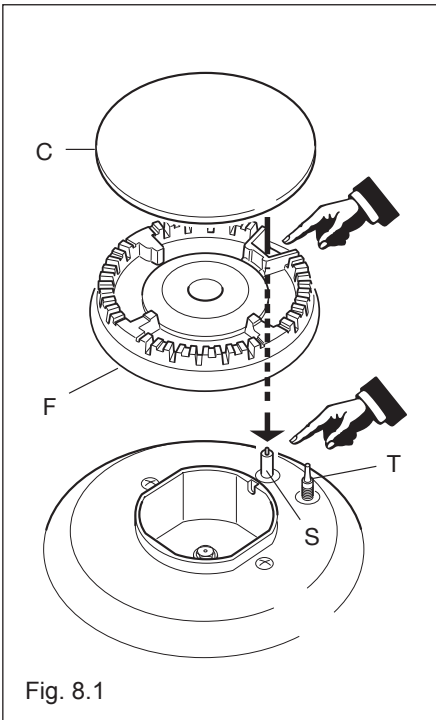

Triple ring burners

The triple ring burner must be correctly positioned (see fig. 8.5); the burner rib must be enter in their logement as shown by the arrow see fig. 8.3).

Then position the cap "A" and the ring "B" (fig. 8.4 - 8.5).
The burner correctly positioned must not rotate (fig. 8.4).

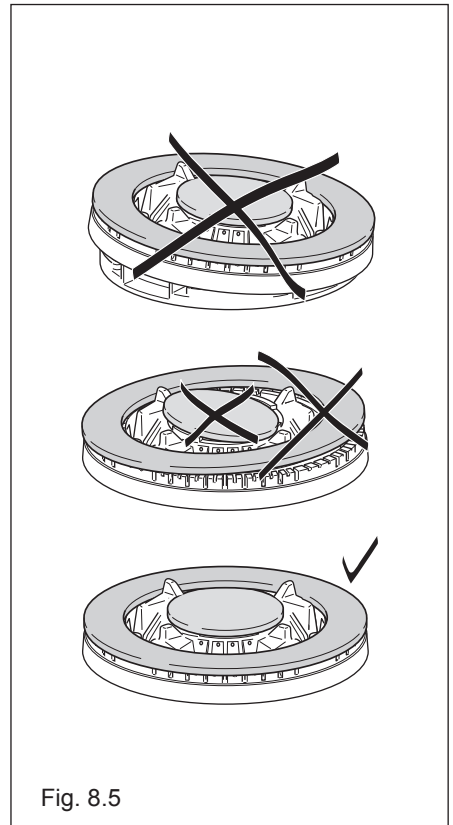
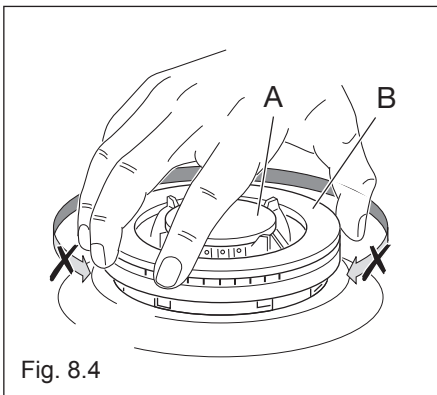
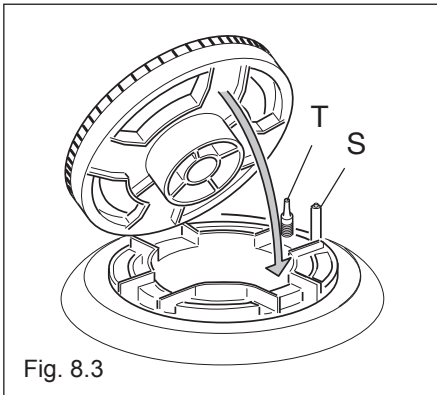

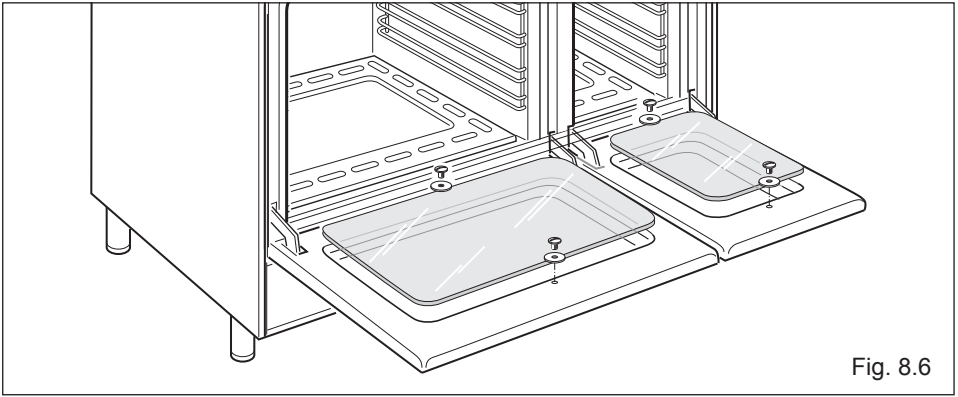

Fig. 8.6

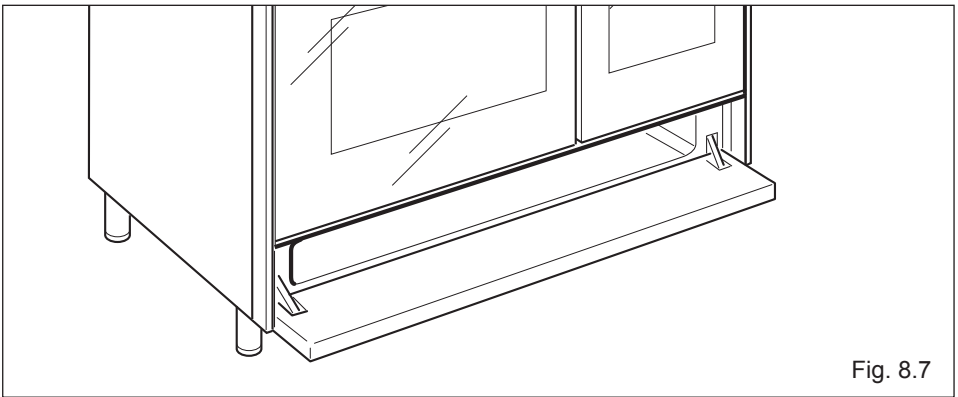

Fig. 8.7

Oven doors

The internal glass panel can be easily removed for cleaning by unscrewing the retaining screws (Fig. 8.6)

Do not use harsh abrasive cleaners or sharp metal scrapers to clean the oven door glass since they can scratch the surface, which may result in shattering of the glass.

Storage compartment

The storage compartment is accessible through the pivoting panel (fig. 8.7).

Do not store flammable material in the ovens or in the storage compartment.

Inside of ovens

The oven should always be cleaned after use when it has cooled down.

The cavity should be cleaned using a mild detergent solution and warm water. Suitable proprietary chemical cleaners may be used after first consulting with the manufacturers recommendations and testing a small sample of the oven cavity. Abrasive cleaning agents or scouring pads/cloths should not be used on the cavity surface.

- **NOTE:** The manufacturers of this appliance will accept no responsibility for damage caused by chemical or abrasive cleaning.

Attention: Do not store flammable material in the ovens.

Let the oven cool down and pay special attention no to touch the hot heating elements inside the oven cavity.

Assembly and dismantling of the side runner frames

- Fit the side runner frames into the holes on the side walls inside the oven (fig. 8.10).
- Slide into the guides, the shelf and the tray (fig. 8.11).
- The rack must be fitted so that the safety notch, which stops it sliding out, faces the inside of the oven; the guard rail shall be at the back.
- To dismantle, operate in reverse order.

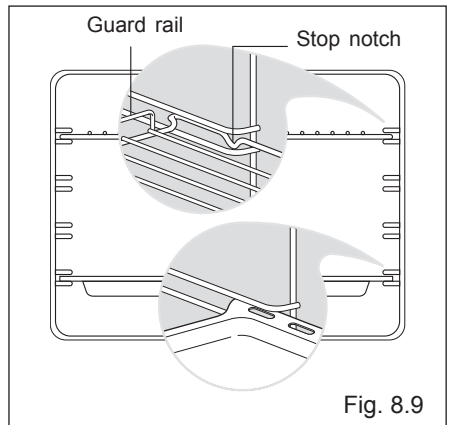
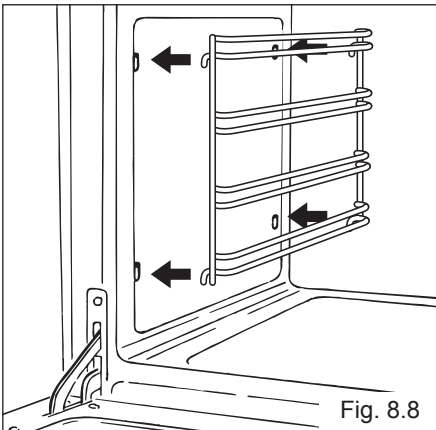

Removing the oven door

The oven door can easily be removed as follows:

- Open the door to the full extent (fig. 8.10a).
- Open the lever “A” completely on the left and right hinges (fig. 8.10b).
- Hold the door as shown in fig. 8.10.
- Gently close the door (fig. 8.10c) until left and right hinge levers “A” are hooked to part “B” of the door (fig. 8.10b).
- Withdraw the hinge hooks from their location following arrow “C” (fig. 8.10d).
- Rest the door on a soft surface.
- To replace the door, repeat the above steps in reverse order.

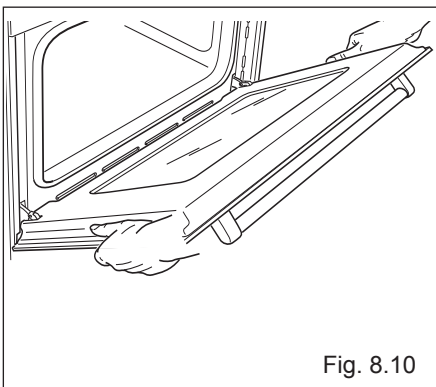
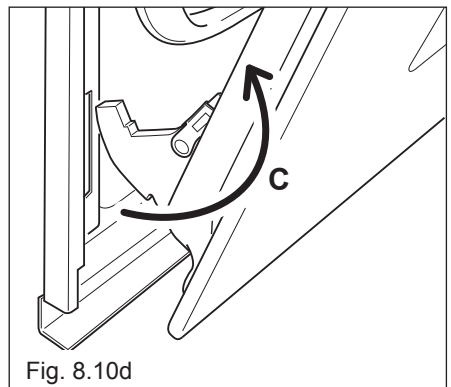
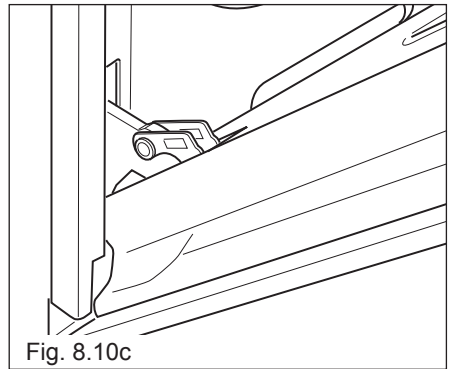
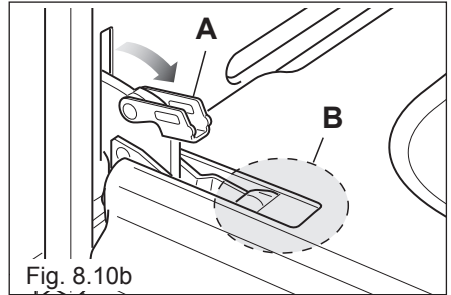
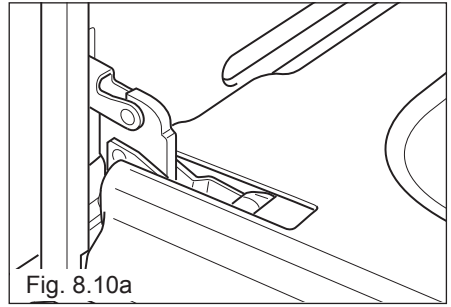

Helpful Advice

Trouble shooting

Problem

Food too brown but not cooked.

Remedy

Turn down the oven temperature slightly and cook a little longer

Problem

Food cooked but not brown enough.

Remedy

Increase temperature.

Problem

Food baking unevenly.

Remedy

1. The temperature may be slightly high turn it down
2. Position the food in the centre of the shelves rather than towards the sides of the oven.
3. Rotate the food a half turn in the oven.
4. Try pre-heating the oven for 5-15 minutes prior to baking.

Always remove cooked items as soon as they are ready and continue cooking the under-cooked items until they are completely finished.

Changing the Oven Cavity Light Bulb.

If the oven light falls:

1. Turn off the oven by switching the oven selector to "O", switch off at the cooker point.
2. When the oven is cool, reach back and upwards inside the oven, the bulb is in the top corner.
3. Unscrew the light glass cover, replace the bulb with a new one of the same specification and screw the cover back until it is hand tight.

NOTE: Oven bulb replacement is not covered by your guarantee.

Other bulbs cannot be changed by yourself and should be replaced by an authorised Caple Service Engineer.

Bulbs other than the oven bulb are covered by the guarantee.

IMPORTANT: Cooker get hot. Keep children away from this appliance at all times.

If Your Oven Does Not Work

Before calling a Caple service engineer run through the following checklist.

1. The cooker is connected to the power supply and that the fuse is intact.
2. Make sure the timer control (main oven only) is set to the manual position, and that the oven has not been set inadvertently for an automatic or timed programme.

If you are in any doubt about carrying out these checks, call Caple on 0844 8003830 or email us via service@caple.co.uk.

A charge will be made if the appliance is found to be in working order, or if it has not been installed in accordance with these instructions, or if it is has been used incorrectly.

Caple "Built-in" Service

Should you require service at any time, please contact Caple Service by telephone on 0844 8003830 or email service@caple.co.uk.

Caple have a nationwide service network of engineers who will respond quickly to your call.

Always replace spare parts with genuine **Caple** spares. These are available from authorised **Caple Service Centres** or by mail order (please check contact details at www.caple.co.uk).

When ordering parts always quote the model number and serial number of your appliance.

YOUR GUARANTEE

Caple guarantees all parts of this product for one year from the date of purchase. During that time, should it become necessary Caple engineers will replace or repair all defective parts free of charge, except for parts subject to fair wear and tear, such as lightbulbs.

Parts and the engineers labour costs are chargeable after the first 12 months.

To qualify for benefits under the guarantee, you must be able to provide proof of date of purchase and the appliance must have been supplied, installed and used for domestic purposes only in accordance with Caple instructions.

Consequential losses and accidental damage to the product are not covered by the guarantee.

This guarantee does not affect your statutory or common law rights.

Caple cannot be responsible for the results of using this appliance for any other purposes other than those described in these instructions.

Caple
Fourth Way
Avonmouth
Bristol
BS11 8DW
www.caple.co.uk