



# **CRG902SS**

**Caple Gas 90cm Range - Stainless Steel**

**INSTRUCTION MANUAL**

Thank you for buying your new CAPLE cooker. To ensure that you get the best results from your new CAPLE cooker, we strongly suggest that you read this instruction manual thoroughly before use. This manual contains installation advice, cleaning tips and a cooking guide, as well as other important facts about your CAPLE cooker. If treated with care, your CAPLE appliance should give you years of trouble-free cooking.

**For Spare Parts, Technical Advice  
or Product Service call the  
CAPLE HELPLINE on 0870 241 1142**

(Answerphone outside office hours)

The **CE** marking confirms that the appliance conforms to the following EU directives:

- safety requirements of EEC Directive "Gas" 90/396;
- safety requirements of EEC Directive "Low voltage" 73/23;
- protection requirements of EEC Directive "EMC" 89/336;
- requirements of EEC Directive 93/68.

# Safety Reminders

---

## Instruction Book

This appliance should only be used for its intended purpose as described in these instructions.

Ensure that you fully understand these instructions before operating this appliance.

## Space Requirements

Ensure that the specified ventilation space around the appliance is not obstructed.

## Food Splashes

Always wipe clean the oven after use. Food splashes can carry on cooking next time and may become a fire hazard.

## Hot Surfaces

It is important to remember that the surfaces of cooking appliances get hot during use and retain the heat for some time after switching off.

It is therefore advisable to keep small children away from the appliance.

## The Grill burner

Is exposed, so take great care when placing food in the oven or removing it. Use the grill pan handles or gloves.

**DO NOT** line the oven, grids, trays etc. with aluminium foil as this could adversely affect the heating elements and it could also damage the interior surfaces.

**DO NOT** place flammable materials in the oven or in the storage compartment.

## Faults

Do not continue to use this appliance if it appears to be faulty.

## After Use

After use, ensure that the hob knobs are in position ● (off), and close the main gas delivery valve or the gas cylinder valve.

Switch the oven controls off.

Always switch off at the isolating switch before cleaning the appliance, or attempting any maintenance task, or when not in use for long periods (when on holiday).

## CAPLE Service

To ensure the continued safe and efficient operation of this appliance, we recommend that any servicing or repairs are carried out only by an authorised CAPLE SERVICE ENGINEER.

# 1 - Electrical Installation

## For your safety please read the following information:

This appliance must be installed by a qualified technician according with the current local regulations and in compliance with the manufacturer instructions.

This appliance is supplied with a moulded 13 amp three pin mains plug with a 3 amp fuse fitted. Should the fuse require replacement, it must be replaced with a fuse rated at 3 amp and approved by ASTA or BSI to BS 1362.

The plug contains a removable fuse cover that must be refitted when the fuse is replaced. In the event of the fuse cover being lost or damaged, the plug must not be used until a replacement cover has been obtained.

Replacement fuse covers can be purchased from your nearest electrical dealer and must be the same colour as the original.

IF THE MOULDED MAINS PLUG IS UNSUITABLE FOR THE SOCKET OUTLET IN YOUR HOME OR IS REMOVED FOR ANY OTHER REASON, THEN THE FUSE SHOULD BE REMOVED AND THE CUT OFF PLUG DISPOSED OF SAFELY TO PREVENT THE HAZARD OF ELECTRIC SHOCK.

THERE IS A DANGER OF ELECTRICAL SHOCK IF THE CUT OFF PLUG IS INSERTED INTO ANY 13 AMP SOCKET OUTLET.

If a replacement plug is to be fitted, please observe the wiring code shown overleaf.

## Warning! This appliance must be earthed

A properly earthed three pin plug (fused at 3 amps, to BS 1362 ASTA approved) must be used.

As the colours of the wires in the mains lead of this appliance may not correspond with the coloured markings identifying the terminals in your plug, proceed as follows.

The wire which is coloured GREEN & YELLOW must be connected to the terminal in the plug which is marked with letter "E" or by the Earth symbol or coloured GREEN & YELLOW.

The wire which is coloured BLUE must be connected to the terminal which is marked with the letter "N" or coloured BLACK.

The wire which is coloured BROWN must be connected to the terminal which is marked with the letter "L" or coloured RED.

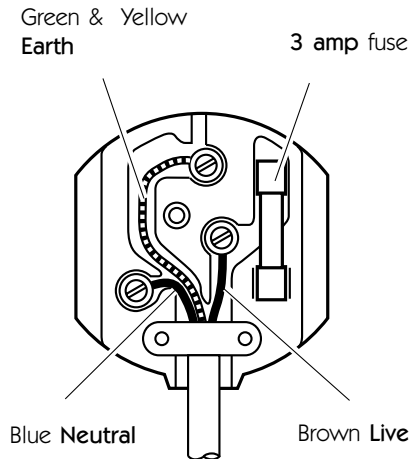

Fig. 1.1

## Replacing the supply cable

The supply cable must be replaced by a cable of the same sort as that fitted to the appliance.

# FOR THE INSTALLER

## 2 - Location

The cooker must be installed by a qualified technician and in compliance with local safety standards.

This cookers has class “2/1” overheating protection so that it can be installed next to a cabinet.

If the cooker is installed adjacent to furniture which is higher than the gas hob cooktop, a gap of at least 50 mm must be left between the side of the cooker and the furniture. The furniture walls adjacent to the cooker must be made of material resistant to heat.

The veneered syntetical material and the glue used must be resistant to a temperature of 90°C in order to avoid ungluing or deformations.

The cooker may be located in a kitchen, a kitchen/diner or bed-sitting room but not in a room containing a bath or shower.

Curtains must not be fitted immediatly behind appliance or within 500 mm of the sides.

It is essential that the cooker is positioned as stated below.

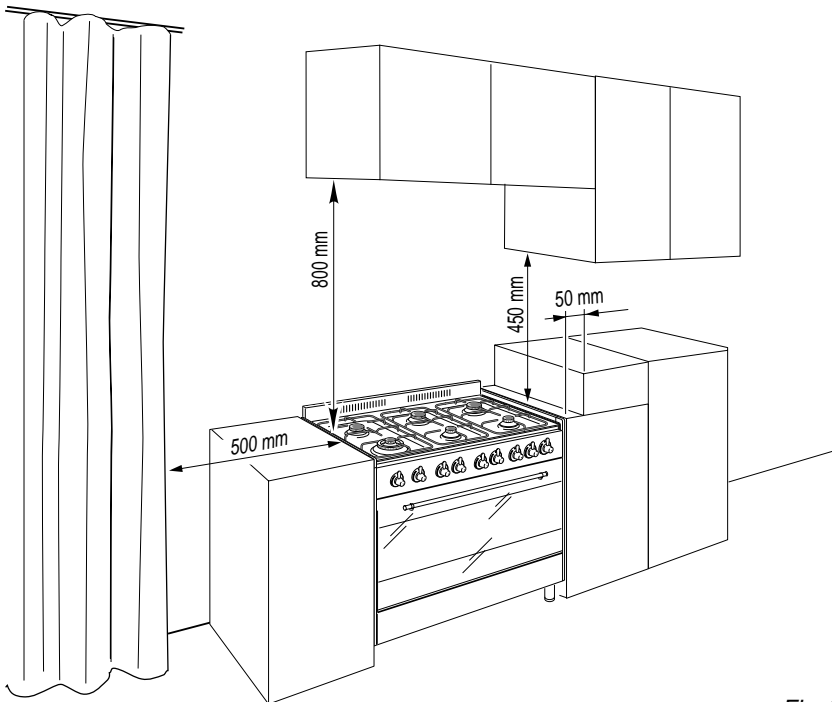
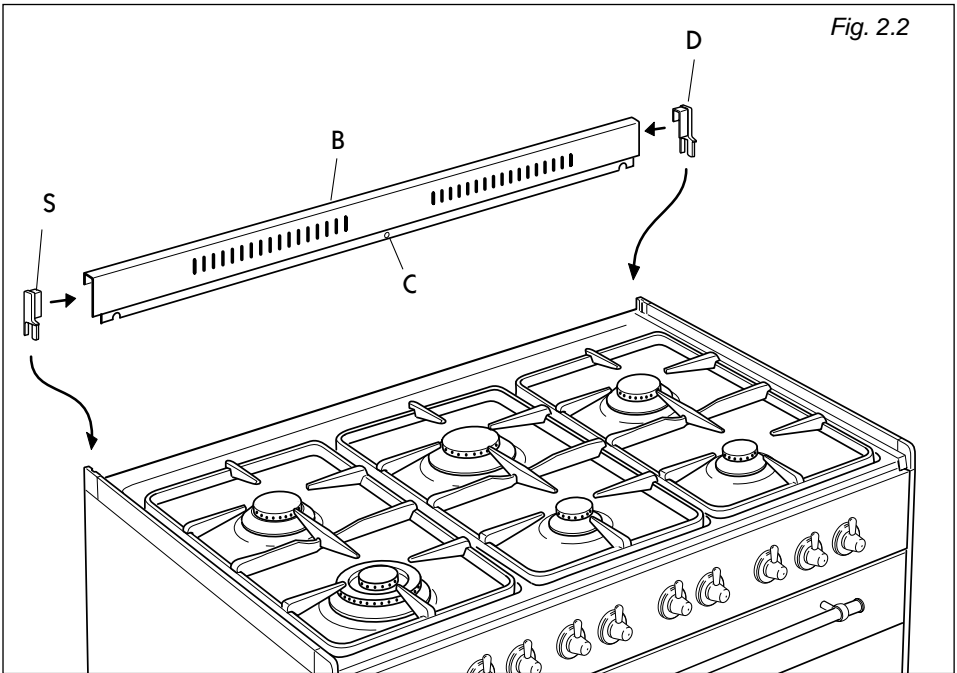

Fig. 2.1 5

## ASSEMBLING THE BACKGUARD

1. Insert the side supports S and D into the backguard B (see fig. 2.2)
2. Insert the backguard group into the support guides in the cooker
3. The backguard can be removed for cleaning or fixed with a screw through the hole C.



## FITTING THE ADJUSTABLE FEET

- The adjustable feet must be fitted to the base of the cooker before use.  
Rest the rear of the cooker on a piece of the polystyrene packaging exposing the base for the fitting of the feet.  
Fit the 4 legs by screwing them tight into the support base as shown in picture 2.4.

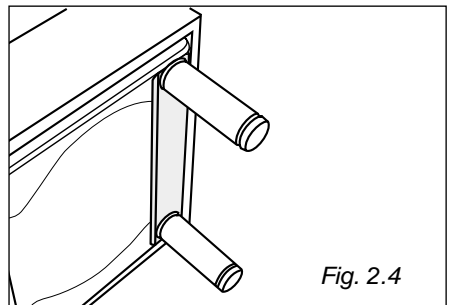
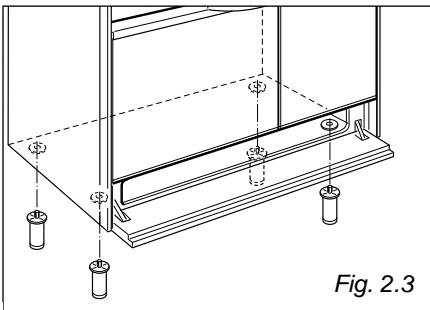

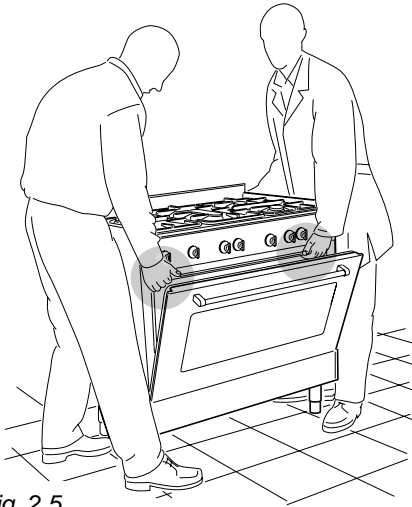

Fig. 2.5

**WARNING**

When raising cooker to upright position always ensure two people carry out this manoeuvre to prevent damage to the adjustable feet (fig. 2.5).

**WARNING**

Be careful! do not lift the cooker by the door handle when raising to the upright position (fig. 2.6).

**WARNING**

When moving cooker to its final position **DO NOT DRAG** (fig. 2.7). Lift feet clear of floor (fig. 2.5).

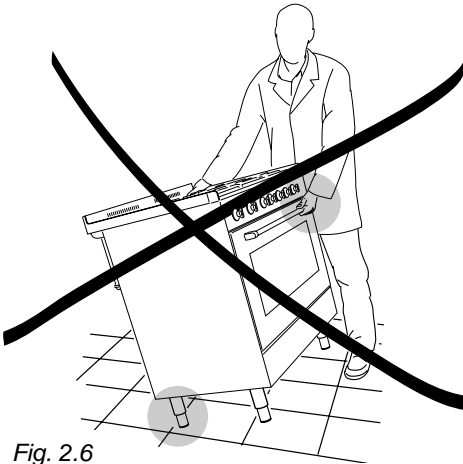

Fig. 2.6

**LEVELLING THE COOKER**

The cooker may be levelled by screwing the lower ends of the feet IN or OUT (fig. 2.8).

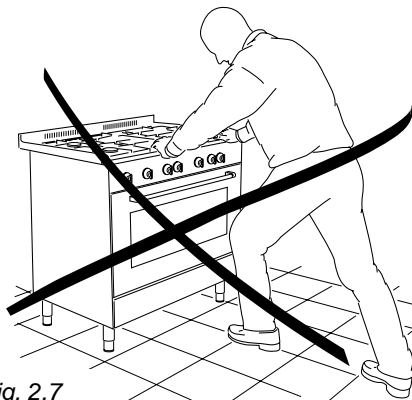

Fig. 2.7

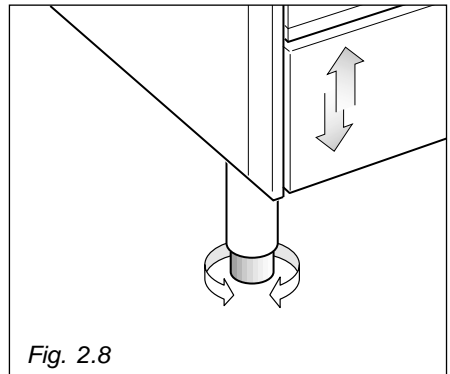

Fig. 2.8

## Provision for ventilation

---

The room containing the cooker should have an air supply in accordance with BS.5540: Part 2: 1989.

All rooms require an openable window or equivalent while some rooms require a permanent vent in addition to the openable window.

The cooker should not be installed in a bed-sitting room, of volume less than 21 m<sup>3</sup>. Where a DOMESTIC COOKER is installed in a room or internal space, that room or internal space shall be provided with a permanent opening which communicates directly with outside air and is sized in accordance with table below. In domestic premises the permanent opening shall be an air vent.

If there are other fuel burning appliances in the same room, BS.5540: Part 2: 1989 should be consulted to determine the requisite air vent requirements.

If the cooker is installed in a cellar or basement, it is advisable to provide an air vent of effective area 100 cm<sup>2</sup>, irrespective of the room volume.

MINIMUM PERMANENT OPENING FREE AREA FOR FLUELESS APPLIANCE						
Type of appliance	Maximum appliance rated input limit	Room volume				Openable window or equivalent also required
		< 5 m <sup>3</sup>	5 m <sup>3</sup> to 10 m <sup>3</sup>	11 m <sup>3</sup> to 20 m <sup>3</sup>	> 20 m <sup>3</sup>	
Domestic oven, hot-plate, grill or any combination thereof.	None	100 cm <sup>2</sup>	50 (*) cm <sup>2</sup>	Nil cm <sup>2</sup>	Nil cm <sup>2</sup>	Yes

(\*) If the room or internal space containing these appliances has a door which opens directly to outside, no permanent opening is required.

# 3 - Gas connection

---

## **GAS INSTALLATION**

### **IMPORTANT NOTE**

This appliance is supplied for use on NATURAL GAS only and cannot be used on any other gas without modification.

This appliance is manufactured for conversion to LPG if required and is supplied with a conversion kit.

The cooker must be installed by a qualified person in accordance with the Gas Safety (Installation and Use) (Amendment) Regulation 1990 and the relevant building/I.E.E. Regulations.

The following British Standards should be used as reference when installing this appliance.

BS6172 1990, BS5440 part 2 1989 and BS6891 1988.

Failure to install the appliance correctly could invalidate any manufacturers warranty and lead to prosecution under the above quoted regulation.

In the UK C.O.R.G.I registered installers are authorised to undertake the installation and service work in compliance with the above regulations.

## **GAS CONNECTION**

The installation of the cooker to Natural Gas or LP Gas must be carried out by a qualified gas engineer. Installers shall take due account of the provisions of the relevant British Standards Code of Practice, the Gas Safety Regulations and the Building Standards (Scotland) (Consolidation) Regulations issued by the Scottish Development Department.

### **INSTALLATION TO NATURAL GAS**

Installation to Natural Gas must conform to the Code of Practice, etc. The supply pressure for Natural Gas is 20 mbar.

### **INSTALLATION TO LP GAS**

This appliance must only be connected to LPG after an LPG conversion kit has been fitted, (see pages from 11 to 17).

When operating on Butane gas a supply pressure of 28-30 mbar is required.

When using Propane gas a supply pressure of 37 mbar is required.

The installation must conform to the relevant British Standards.

Warning: Only a qualified gas engineer, also with technical knowledge of electricity should install the cooker. He should observe the Regulations and Codes of Practice governing such installation of gas cookers.

Note: It is recommended that the gas connection to the cooker is installed with a flexible connecting tube made to BS 5386.

## GAS CONNECTION

The gas supply must be connected to the gas inlet which is located at the left or the right hand rear of the appliance (fig. 3.1).

The pipe does not cross the cooker.

When screwing the connecting tube operate with two spanners (fig. 3.2).

The unused end inlet pipe must be closed with the plug, interposing the gasket.

**After connecting to the mains, check that the coupling are correctly sealed, using soapy solution, but never a flame.**

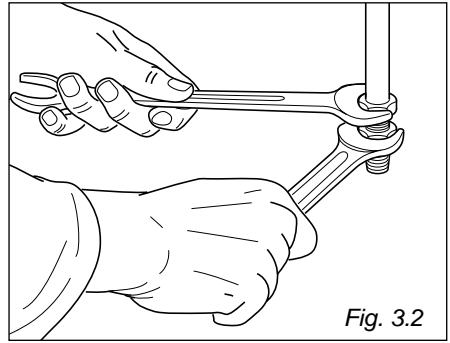

Fig. 3.2

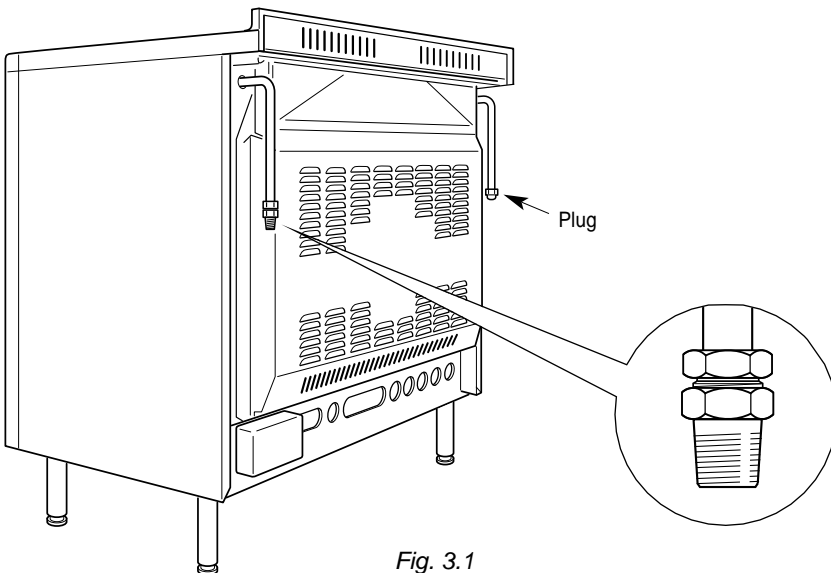

Fig. 3.1

# Conversion to LPG

## Injectors replacement of top burners

To replace the injectors it is necessary to lift the hobtop and proceed as follows:

- Remove pan-supports and burners from the hobtop.
  - Remove the backguard “E”.
  - Unscrew the two screws “B” and remove the sockets (Fig. 3.3).
  - Unscrew the two screws “C” and remove the two side trims and joints pulling upwards.
  - Pull forwards the hobtop to release it, then lift following arrow “D” (Fig. 3.3)
  - Hold the hobtop open by a support.
  - Fully raise the adjusting air tube A (fig. 3.4) in order to easily reach the injector.
  - By an angle 7 spanner, remove injector “J” from its housing and replace it with the correct one depending on the kind of gas (see following table - page 13).
- Each injector can be identified by the engraving of the hole diameter expressed in hundredths of a millimetre.

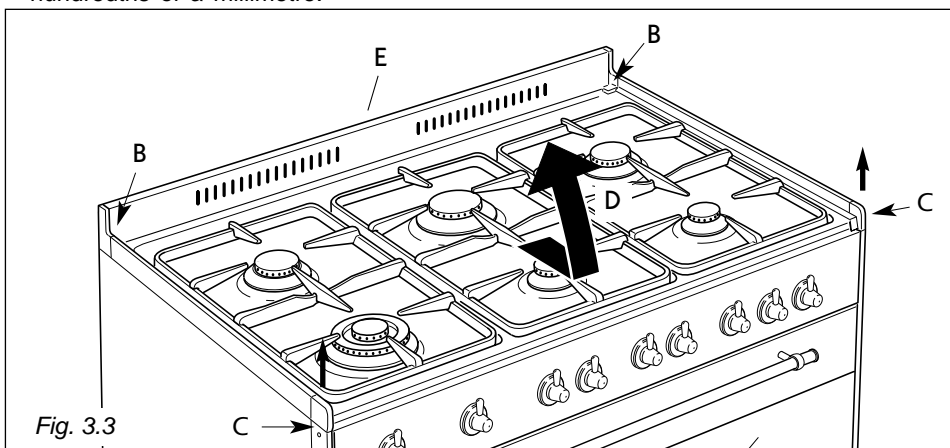

## Adjusting of primary air of the top burners

By operating the screw “M”, reset the air adjuster “A” according to the instructions see “TABLE FOR THE CHOICE OF THE INJECTORS”, where the distance between injector and air adjuster is recommended (in mm).

Before lowering the hob top, set the burners on their sites and light them in order to check whether the flames are correct, as per the specifications given in the next page. In case of uncorrect flame, lift or lower the air adjuster.

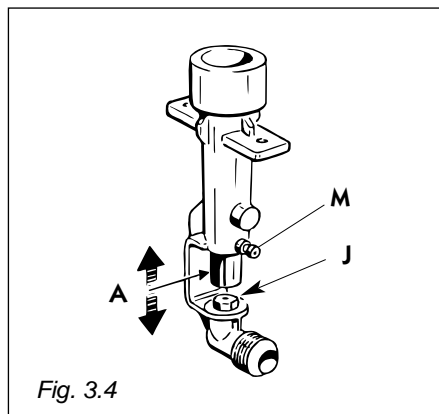

Flame faulty in primary air	Flame correct	Flame with excess primary air
long, yellow and trembling	clear interior blue cone	short and sharp too blue interior cone tending to detach
CAUSE		
air regulating tube, too closed	correct distance of the tube	air regulating tube, too open

## Adjusting of the minimum of the top burners

Considering that in the minimum position the flame must have a length of about 4 mm and must remain lit even with a brusque passage from the maximum position to that of minimum.

The flame adjustment is done in the following way:

- Turn on the burner
- Turn the tap to the MINIMUM position
- Take off the knob
- With a small flat screwdriver turn the screw inside the tap rod to the correct regulation (fig. 3.5).

Normally for LPG, tighten up the regulation screw.

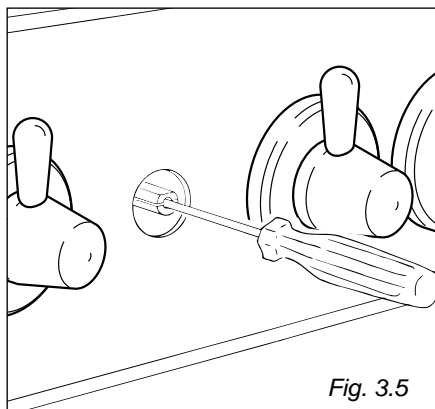

BURNERS	Nominal Power [kW]	Reduced Power [kW]	G 30 - 28-30 mbar G 31 - 37 mbar			G 20 20 mbar		
			By-pass [1/100 mm]	Ø injector [1/100 mm]	Ring opening [mm]	By-pass [1/100 mm]	Ø injector [1/100 mm]	Ring opening [mm]
Auxiliary (A)	1,00	0,30	27	50	3 *	adjustable	72	1 *
Semi-rapid (SR)	1,90	0,38	29	67	5,7 *		100	2 *
Rapid (R2)	2,95	0,60	39	83	fully open *		125	3 *
Double-ring	3,45	0,85	47	92	fully open *		135	5 *
Oven	6,20	1,30	58	120	8 *		180	1,5 *
Grill	4,65	-	-	107	fully open *	-	165	3 *

\* = Reference value

**INCREASE OF AIR NECESSARY FOR GAS COMBUSTION (2 m<sup>3</sup>/h x kW)**

BURNERS	Air necessary for combustion [m <sup>3</sup> /h]
Auxiliary (A)	2,00
Semi-rapid (SR)	3,80
Rapid (R2)	5,90
Double-ring	6,90
Oven	12,40
Grill	9,30

# Oven burner and grill burner replacement of injectors

## a) oven burner

- Lift and remove the lower panel inside the oven.
- Unscrew and remove the burner securing screw A (fig. 3.6).
- Slacken screw B (fig. 3.6).
- Withdraw the burner in the manner shown in figure 8.7, and rest it inside the oven. Take care not to damage the wire to the ignition electrode and the safety valve probe.
- Using a 10 mm box spanner, unscrew the injector (indicated by the arrow in fig. 3.7) and replace with a new injector selected in accordance with the "TABLE FOR THE CHOICE OF THE INJECTORS"; then replace the burner repeating the above steps in reverse order.

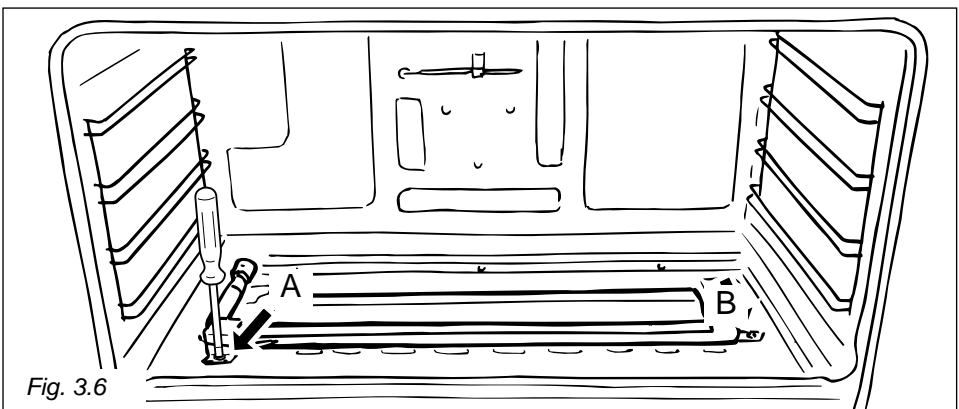
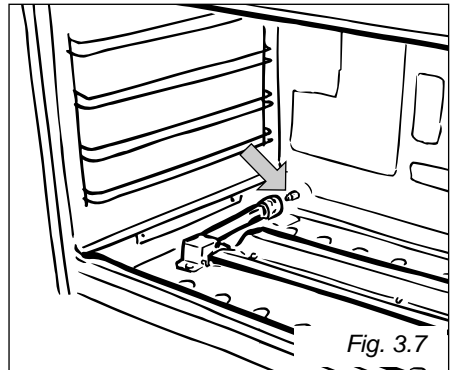

## b) grill burner

- Unscrew and remove the burner securing screw 'C' (fig. 3.8).
- Slacken screw 'D' (fig. 3.8).
- Move the burner in the manner shown in figure 8.9.  
Take care not to damage the wire to the ignition electrode and the safety valve probe.
- Using a 10 mm box spanner, unscrew the injector (indicated by the arrow in fig. 3.9) and replace with a new injector selected in accordance with the "TABLE FOR THE CHOICE OF THE INJECTORS"; then replace the burner repeating the above steps in reverse order.

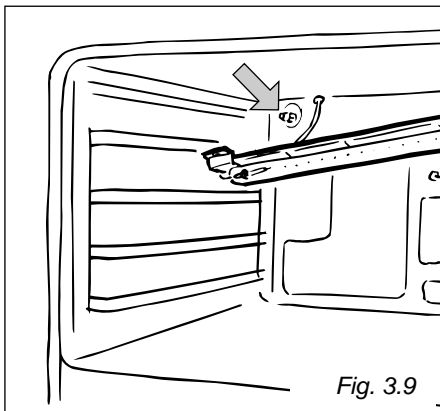

Fig. 3.9

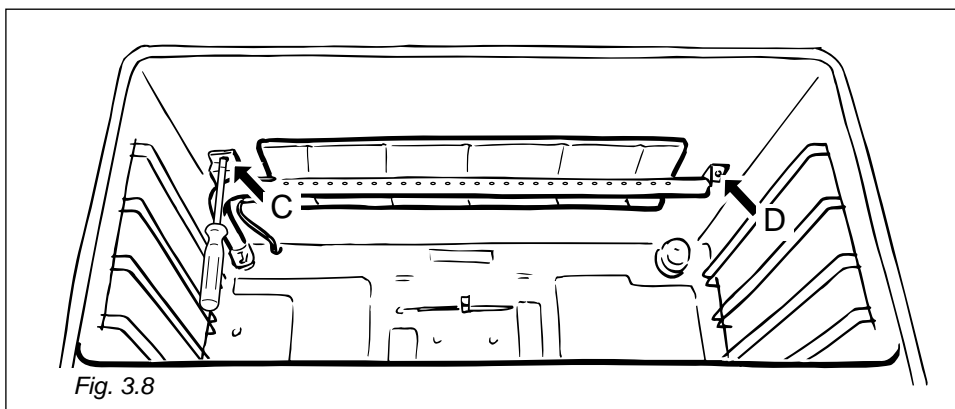

Fig. 3.8

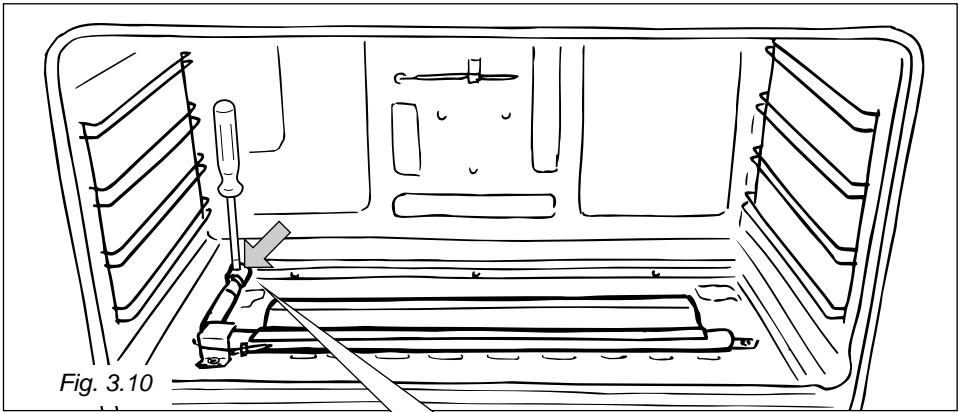

Fig. 3.10

## Regulation of air supply to oven and grill burners

Using a cross-head screwdriver, slacken the screw securing the air flow regulation collar (fig. 3.10 and 3.11) and move the collar forward or backward to increase or reduce the air aperture in accordance with gas type and the indications in the "TABLE FOR THE CHOICE OF THE INJECTORS". Light the burner and check the flame.

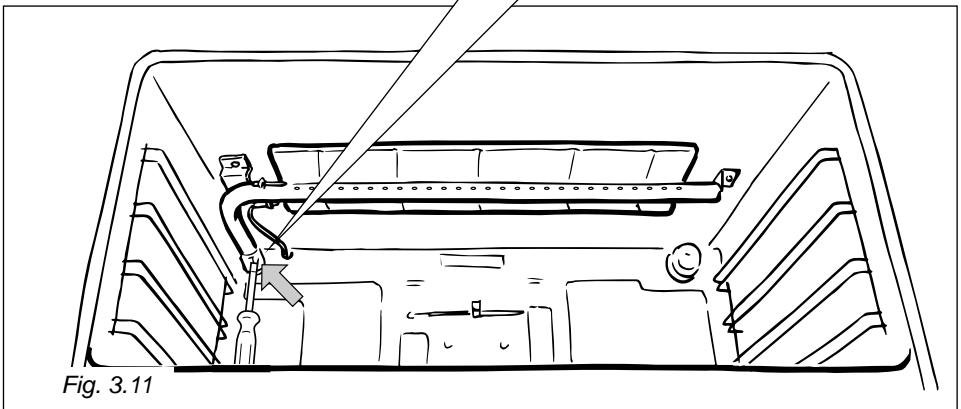
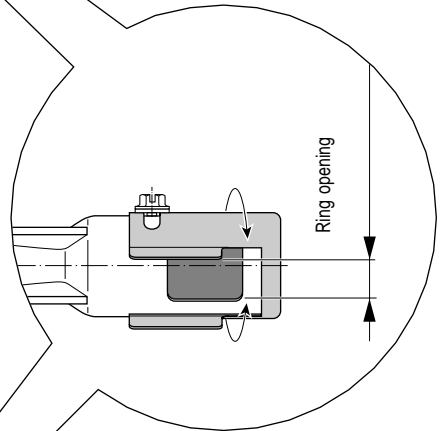

Fig. 3.11

## Adjustment of the oven burner minimum

To be effected only for the oven burner (as the grill burner has an only fixed input) operating on the thermostat as follows:

- Light the oven taking the knob to Max. position.
- remove the knob and by a thin screw-driver (3 mm section - 100 mm long) unscrew of about a half turn the screw by-pass G, passing through the front panel hole (fig. 3.12)
- fit the knob and let the oven heat for 10 minutes, then take the knob to position 150 allowing the thermostat to work under by-pass.
- after further removal of the knob, stop slowly the screw by-pass G (being careful not to turn the knob rod) until the flame reaches 3-4 mm high.

**N.B. For LPG the by-pass screw must be fixed thoroughly.**



Flame correct



Flame faulty in primary air

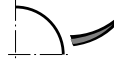

Flame with excess primary air

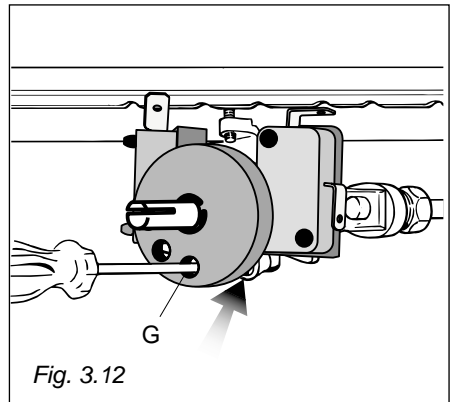

Fig. 3.12

## Lubrication of the gas taps

If the gas tap becomes stiff, it is necessary to dismount it accurately clean it with gasoline and spread a bit of special grease resistant to high temperatures on it.

The operations must be executed by a qualified technician.

# 4 - Features and Technical Data

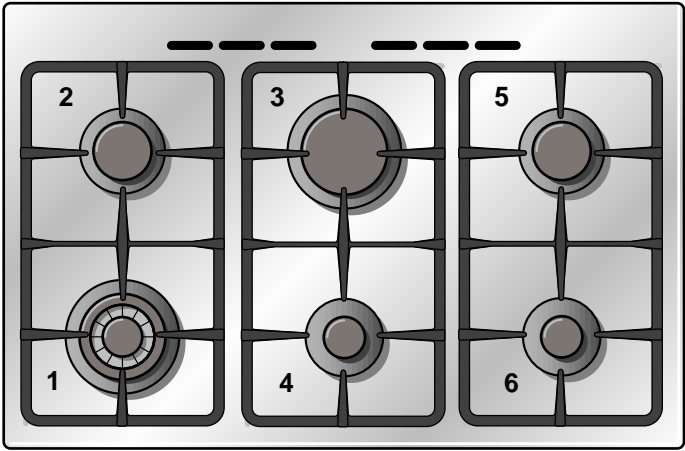

Fig. 4.1

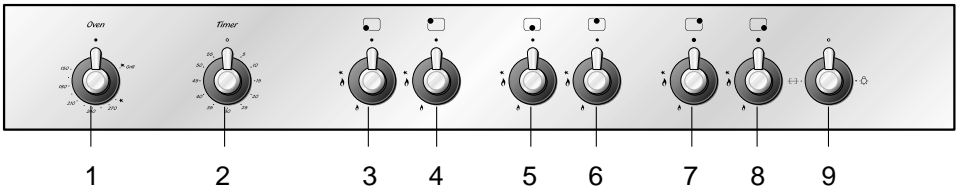

Fig. 4.2

## Cooking hob - (Fig. 4.1)

- |                            |         |
|----------------------------|---------|
| 1. Double-ring burner (PB) | 3,45 kW |
| 2. Semi-rapid burner (SR)  | 1,90 kW |
| 3. Rapid burner (R2)       | 2,95 kW |
| 4. Auxiliary burner (A)    | 1,00 kW |
| 5. Semi-rapid burner (SR)  | 1,90 kW |
| 6. Auxiliary burner (A)    | 1,00 kW |

## Control panel - (Fig. 4.2)



1. Gas oven/gas grill control knob
2. Minute counter
3. Front left burner control knob
4. Rear left burner control knob
5. Front central burner control knob
6. Rear central burner control knob
7. Rear right burner control knob
8. Front right burner control knob
9. Rotisserie/oven light control knob

# How To Use the Hob Burners

---

## Hob burners

Each hob burner is controlled by a separate gas tap operated by a control knob (fig. 4.3) which has 3 positions marked on the control panel, these are:

- Symbol ● : tap closed (burner off)
- Symbol  : High (maximum)
- Symbol  : Low (minimum)

Push in and turn the knob anti-clockwise to the selected position.

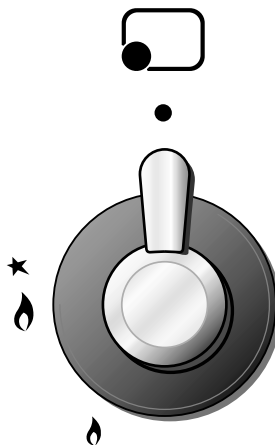
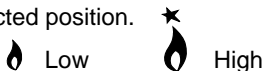

Fig. 4.3

To turn the burner off, fully rotate the knob clockwise to the off position: ●.

The maximum setting of the control tap is for boiling, the minimum setting is for slow cooking and simmering.

All working positions must be chosen between the maximum and minimum setting, never between the maximum setting and the “OFF” position.

## Lighting of the hob burners

To ignite the burner, the following instructions are to be pursued:

- 1) Lightly press and turn the knob anti-clockwise, and make the symbol  printed on the control panel to match with the indicator on the knob (fig. 4.3).
- 2) Press the knob to operate the electric ignition; or, in case of power cut, approach a flame to the burner.
- 3) Adjust the burner according to the power required.

## Electric ignition

The sparks generated by the electrodes close to the burners will ignite the chosen burner. Whenever the lighting of the burners will result difficult due to peculiar conditions of the gas features or supply, it is advised to repeat the ignition with the knob on “minimum” position.

# Choice of burner

---

The burner must be chosen according to the diameter of the pans and energy required.

Burners	Pan diameter
Auxiliary	12 ÷ 16 cm
Semi-rapid	16 ÷ 22 cm
Rapid	20 ÷ 24 cm
Double-ring	up to 30 cm
Wok	max 36 cm

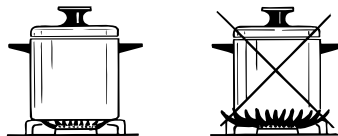

**do not use pans with concave or convex bases**

*Fig. 4.4*

Saucepans with handles which are excessively heavy, in relationship to the weight of the pan, are safer as they are less likely to tip.

Pans which are positioned centrally on burners are more stable than those which are offset.

It is far safer to position the pan handles in such a way that they cannot be accidentally knocked.

When deep fat frying fill the pan only one third full of oil.

**DO NOT** cover the pan with a lid and **DO NOT** leave the pan unattended.

In the unfortunate event of a fire, leave the pan where it is and turn off all controls.

Place a damp cloth or correct fitting lid over the pan to smother the flames.

**DO NOT** use water on the fire.

Leave the pan to cool for at least 30 minutes.

## Correct use of double-ring burner

The flat-bottomed pans are to be placed directly onto the pan-support.  
When using a WOK you need to place the supplied stand in the burner to avoid any faulty operation of the double-ring burner.

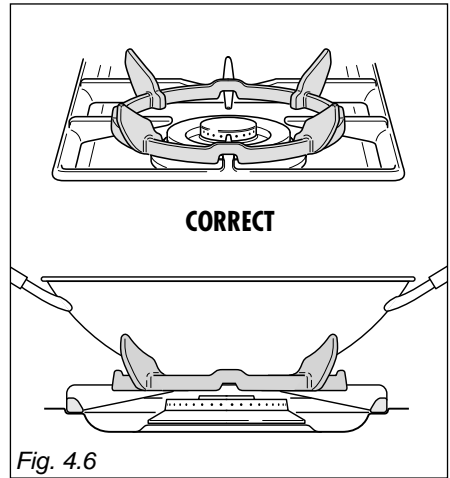
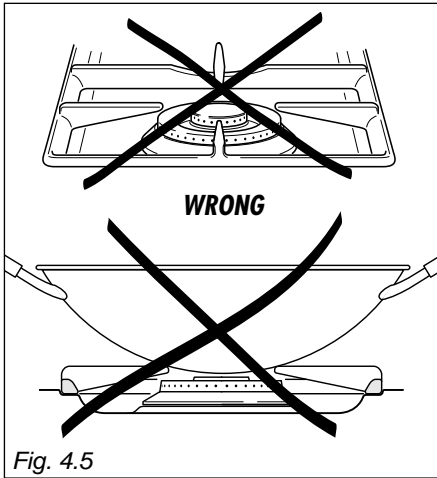

# 5 - Minute counter

---

## Minute counter

The minute counter is a timed acoustic warning device which can be set for a maximum of 60 minutes.

The knob (Fig. 5.1) must be rotated clockwise as far as the 60 minute position and then set to the required time by rotating it anticlockwise.

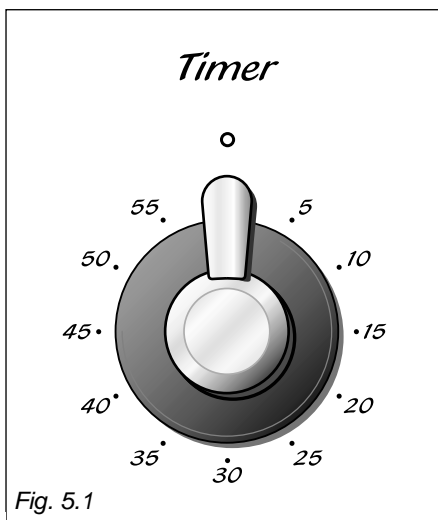

# 6 - How To Use the Gas oven

---

**Attention: the oven door becomes very hot during operation. Keep children away.**

## General features

The oven is furnished completely clean; it is advisable, however, upon first use, to turn the oven on to the maximum temperature (position • ✱) to eliminate possible traces of grease from the oven burner. The same operation should be followed for grill burner.

The gas oven is provided with two burners:

- a) Oven burner, mounted on the lower part of the oven (wattage: 6,20 kW)
- b) Grill burner, mounted on the upper part of the oven (wattage: 4,65 kW).

## Oven burner

It carries out normal “oven cooking”.

The gas flow to the burner is regulated by a thermostat which allow to maintain the oven temperature constant.

The control of the temperature is assured by a thermostatic probe positioned inside the oven.

The probe must be always kept in its housing, in a clean condition, as an incorrect position or encrustment may cause an alteration in the control of the temperature.

## Ignition of the oven burner

The thermostat allows the automatic control of the temperature.

The gas delivery to the oven burner is controlled by a two way thermostatic tap (oven and grill burners) with flame-failure device.

To light the oven burner operate as follow:

- 1) **Open the oven door**
- 2) Lightly press and turn the thermostat knob anti-clockwise to max position “• ✱”.
- 3) Press the knob right down to prime the electric ignition.  
**WARNING: Risk of explosion! The oven door must be open during this operation.**  
In case of power cut, press the knob and immediately approach a lighted match to the opening “A” (fig. 6.3).
- 4) Wait about 10/15 seconds after the burner lighting before releasing the knob (time of priming of the valve).
- 5) Close the oven door slowly and adjust the burner according to the power required.

If the flame extinguishes for any reason, the safety valve will automatically shut off the gas supply to the burner.

To re-light the burner, first turn the oven control knob to position ●, **wait for at least 1 minute and then repeat the lighting procedure.**

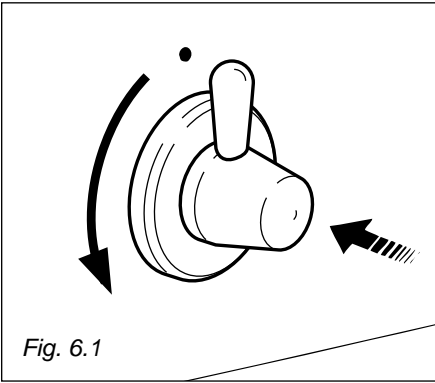

Fig. 6.1

## Oven thermostat

The oven thermostat (fig. 6.2) is marked with numbers, these correspond to the oven temperature, in addition the "OFF" position is shown by the symbol "●".

To choose the required oven temperature (check with the "Oven cooking temperatures"), turn the control knob until its line mark is level with the number required on the control panel (facia).

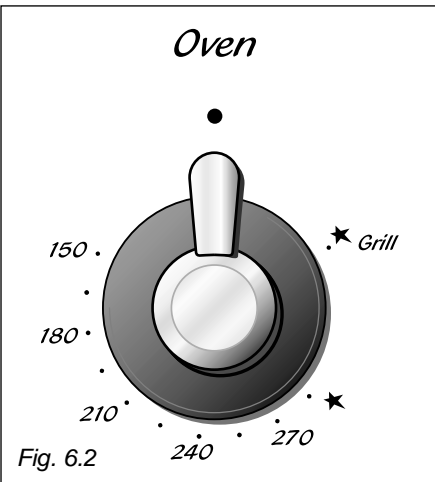

Fig. 6.2

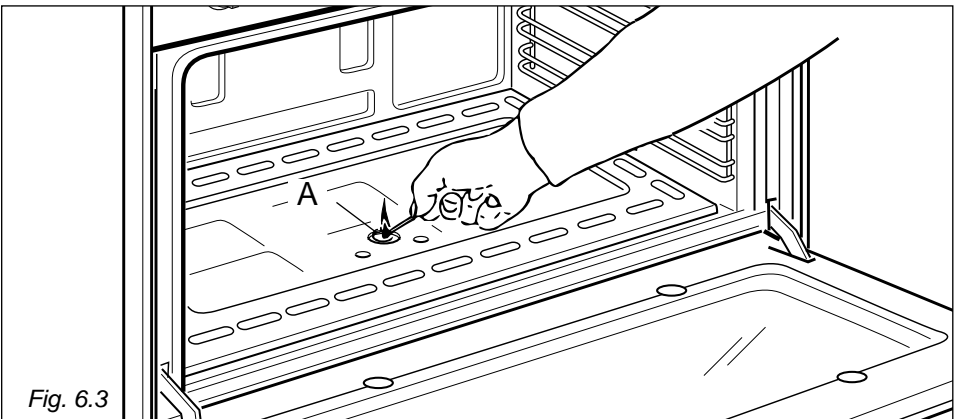

Fig. 6.3

## Oven cooking

Before introducing the food, preheat the oven to the desired temperature.

For a correct preheating operation, it is advisable to remove the tray from the oven and introduce it together with the food, when the oven has reached the desired temperature.

Check the cooking time and turn off the oven 5 minutes before the theoretical time to recuperate the stored heat.

## Cooking examples

Temperatures and times are approximate as they vary depending on the quality and amount of food.

Remember to use ovenproof dishes and to adjust the oven temperature during cooking if necessary.

### DISHES TEMPERATURE

Lasagne	190°
Baked pasta	190°
Pizza	220°
Creole rice	190°
Baked onions	190°
Spinach crêpes	185°
Potatoes baked in milk	185°
Stuffed tomatoes	180°
Cheese soufflé	170°
Roast veal	180°
Grilled veal chops	210°
Chicken breasts with tomato	180°
Grilled chicken - roast chicken	190°
Veal loaf	175°
Roast beef	170°
Fillet of sole	175°
Aromatic hake	170°
Beignets	160°
Ring cake	150°
Plum tart	170°
Jam tartlets	160°
Sponge cake	170°
Sweet dough	160°
Sweet puffs	170°
Plain sponge cake	170°

## Ignition of the grill burner

**Do not grill with oven door closed. Always fit the heat shield supplied with the cooker under the front panel before commencing operations (Fig. 6.6).**

**WARNING.** The heat shield and the oven door reaches a very high temperature whilst in use. Keep children away and allow to cool before removing.

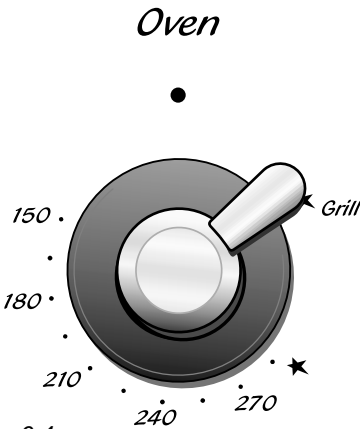



Fig. 6.4

The grill burner generates the infra-red rays for grilling.

To light the grill burner operate as follow:

- 1) **Open the oven door.**
- 2) Lightly press and turn the thermostat knob clockwise to the  **Grill** position (fig. 6.4).
- 3) Press the knob right down to prime the electric ignition.

**WARNING: Risk of explosion! The oven door must be open during this operation.**

In case of power cut, press the knob and put a lighted match to the right and left side of the burner (fig. 6.5).

**Never continue this operation for more than 15 seconds. If the burner has still not ignited, wait for about 1 minute prior to repeating the ignition.**

- 4) Wait about 10/15 seconds after the burner lighting before releasing the knob (time of priming of the valve).
- 5) Half-close the oven door slowly.

If the flame extinguishes for any reason, the safety valve will automatically shut off the gas supply to the burner.

To re-light the burner, first turn the oven control knob to position , wait for at least 1 minute and then repeat the lighting procedure.

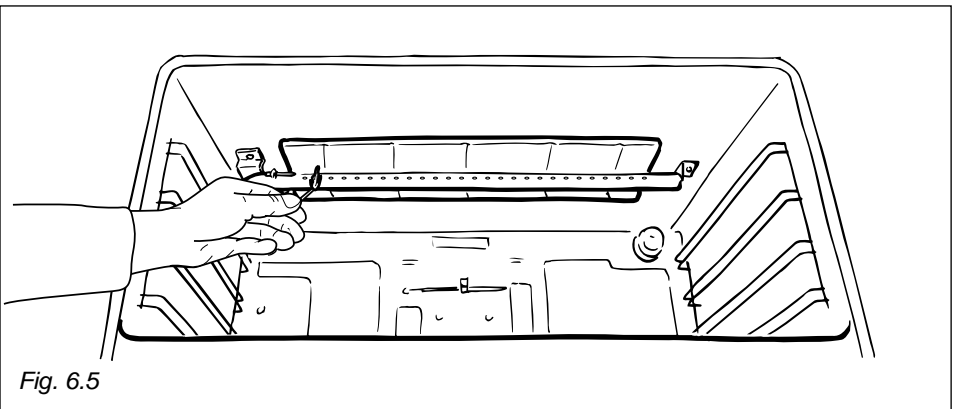

Fig. 6.5

**Notes:**

- The grill burner has only one setting, that is full-on
- It is important that the heat shield is fitted the correct way up, as shown in the figure 6.6.

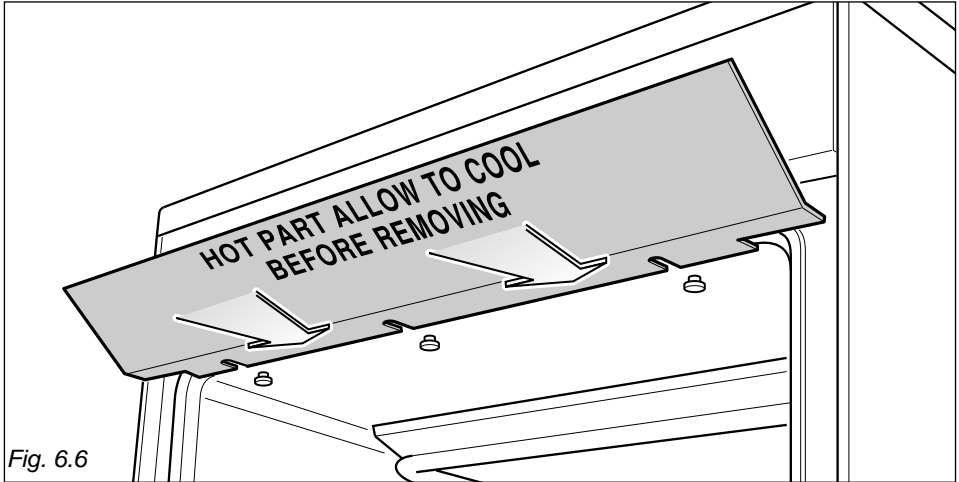

Fig. 6.6

**IMPORTANT WARNING**

For best results when using the grill, place the shelf on the second level and when using the grill pan handle avoid contact with the heat shield which will be **HOT** during use

**Oven light**

The cooker is equipped with a light that illuminates the oven to enable visually controlling the food that is cooking.

This light is controlled by a switch knob (fig. 6.7).

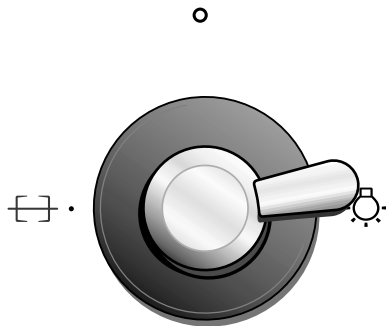

Fig. 6.7

## Rotisserie

This is used for spit roasting under the grill and comprises:

- an electric motor fitted to the rear of the oven
- a stainless steel skewer provided with slide-out heatless handgrip and two sets of adjustable forks
- a skewer support to be fitted in the middle runner.

The rotisserie motor is operated by the knob illustrated in fig. 6.8.

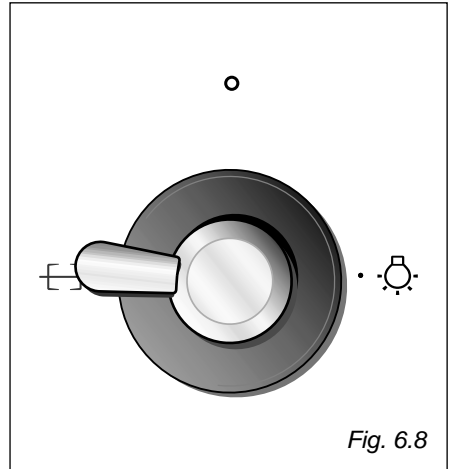

Fig. 6.8

## Use of the rotisserie

- Insert the tray into the lowest rack holder of the oven and insert the rod support into the intermediate rack holders.
- Put the meat to be cooked onto the rod, being careful to secure it in the center with the special forks.
- Insert the rod into the side gear opening “P” (fig. 6.9)
- Remove the grip “H” by turning it to the left.
- Insert completely the rotisserie support; the shaft “S” must be inserted in the spit motor collar “G”.

The rotation direction of the rotisserie can be either clockwise or counter-clockwise.

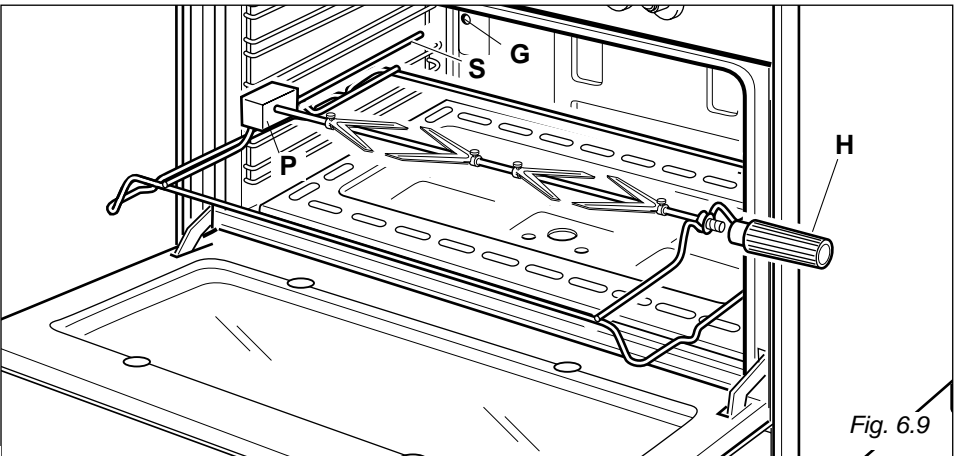

Fig. 6.9

# 7 - Cleaning and Maintenance

---

## **GENERAL ADVICE**

---

- When the appliance is not being used, it is advisable to keep the gas tap closed.
  - Every now and then check to make sure that the flexible tube that connects the gas line or the gas cylinder to the appliance is in perfect condition and eventually substitute it if it shows signs of wearing or damage.
  - The periodical lubrication of the gas taps must be done only by specialized personnel.
  - If a tap becomes stiff, do not force; contact your local Service Centre.
- **Important:**  
**Before any operation of cleaning and maintenance disconnect the appliance from the electrical network.**

### **Attention**

The appliance gets very hot, mainly around the cooking areas. It is very important that children are not left alone in the kitchen when you are cooking.

Do not use a steam cleaner because the moisture can get into the appliance thus make it unsafe.

## Cleaning

All the enamelled parts must be cleaned with a sponge and soapy water or other non-abrasive products.

Dry preferably with a soft cloth.

Acidic substances like lemon juice, tomato sauce, vinegar etc. can damage the enamel if left too long.

## Stainless steel surfaces

The stainless steel front panels on this cooker (facia, oven door, storage compartment) are protected by a finger-print proof lacquer.

To avoid damaging this lacquer, do not clean the stainless steel with abrasive cleaners or abrasive cloths or scouring pads.

**ONLY SOAP/WARM WATER MUST BE USED TO CLEAN THE STAINLESS STEEL SURFACES.**

## Replacing the oven light bulb

**Switch the cooker off at the mains.**

When the oven is cool unscrew and replace the bulb with another one resistant to high temperatures (300°C), voltage 230 V (50 Hz), 15 W, E14.

Note: Oven bulb replacement is not covered by your guarantee.

## Inside of oven

This must be cleaned regularly.

Remove and refit the side runner frames as described on the chapter "Assembly and dismantling of the side runner frames".

With the oven warm, wipe the inside walls with a cloth soaked in very hot soapy water or another suitable product.

The bottom of the oven, side runner frames, tray and rack can be removed and washed.

## Burners

They can be removed and washed only with soapy water.  
Detergents can be used but must not be abrasive or corrosive.  
Do not use abrasive sponges or pads.  
Do not put in dishwasher.

After cleaning or washing, check that burner-caps and burner-heads are dry before placing them in the respective housings.

**Special attention has to be paid in order not to exchange the housing of the small burners shown in fig. 7.1.**

It is absolutely necessary to check the perfect housing of the burner-ring as an incorrect housing may cause serious problems.  
Check also that the electrodes for ignition are always clean in order to ensure a regular spark.

**N.B. To avoid damage to the electric ignition, do not use it when the burners are not in place.**

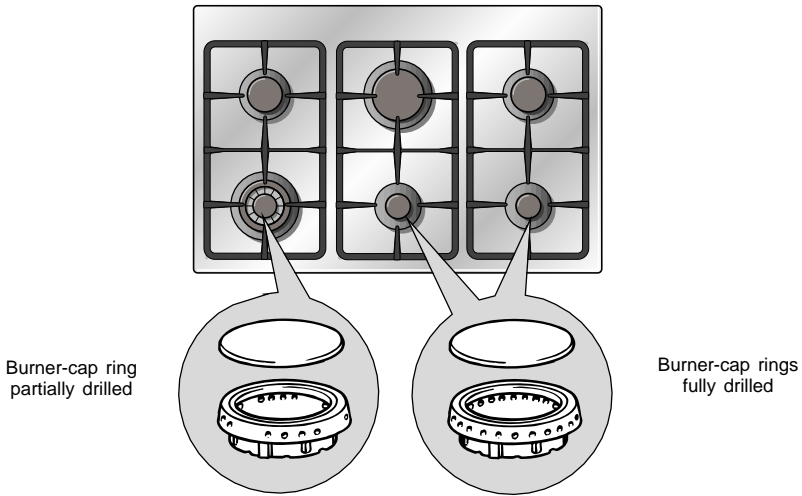

Fig. 7.1

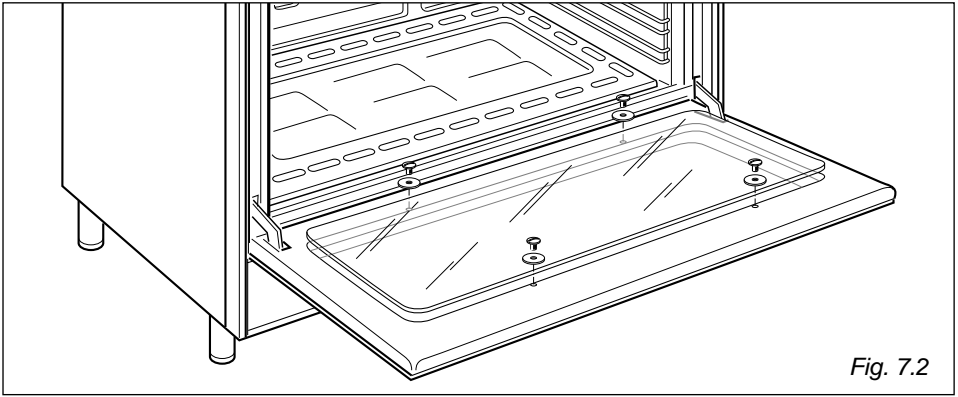

Fig. 7.2

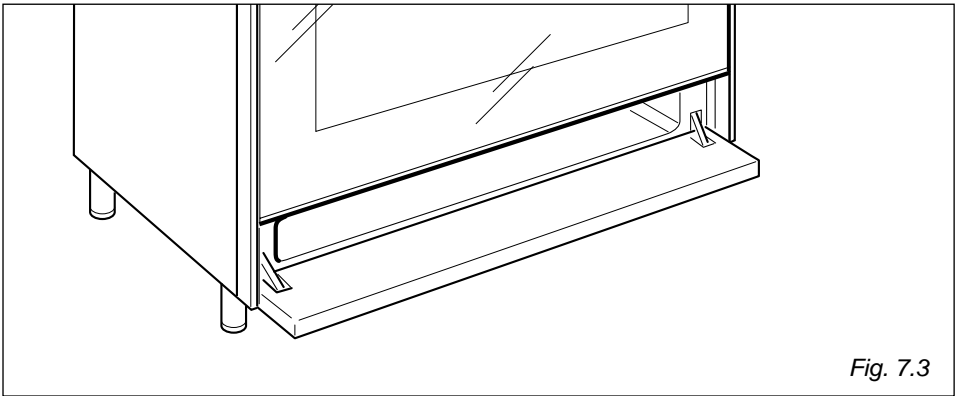

Fig. 7.3

## Oven door

The internal glass panel can be easily removed for cleaning by unscrewing the 4 retaining screws (Fig. 7.2)

## Storage compartment

The storage compartment is accessible through the pivoting panel (fig. 7.3).

**Do not store flammable material in the oven or in the storage compartment.**

## Assembly and dismantling of the side runner frames

- Fit the side runner frames into the holes on the side walls inside the oven (Fig. 7.4).
- Slide the tray and rack into the runners (Fig. 7.5).
- To dismantle, operate in reverse order.

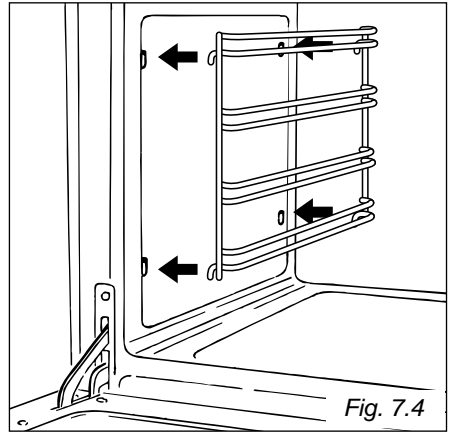

## Oven floor

The oven floor "F" (fig. 7.6) can be easily removed to facilitate cleaning. Remember to replace the floor correctly afterwards. Be careful not to confuse the tray "L" with the oven floor "F".

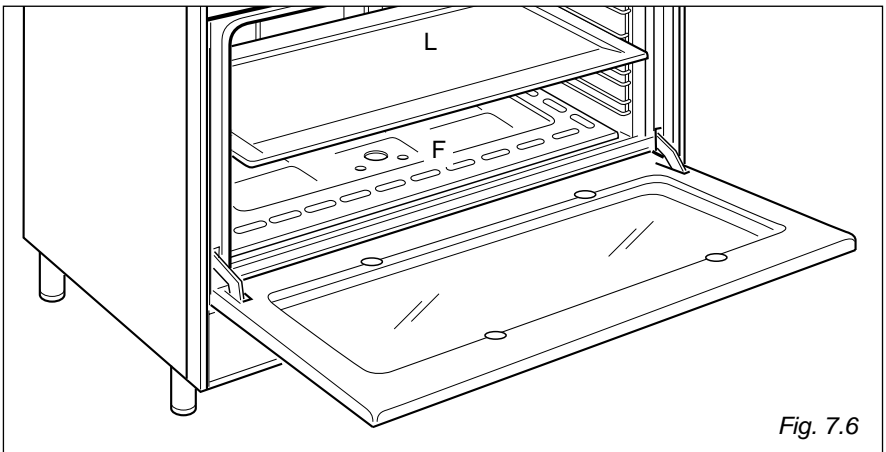
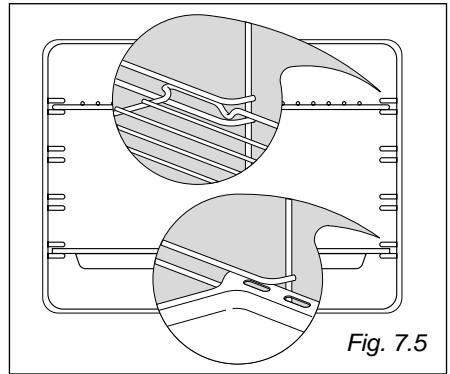

## Removing the oven door

The oven door can easily be removed as follows:

- Open the door to the full extent (fig. 7.7A).
- Attach the retaining rings to the hooks on the left and right hinges (fig. 7.7B).
- Hold the door as shown in fig. 7.7.
- Gently close the door and withdraw the lower hinge pins from their location (fig. 7.7C).
- Withdraw the upper hinge pins from their location (fig. 7.7D).
- Rest the door on a soft surface.
- To replace the door, repeat the above steps in reverse order.

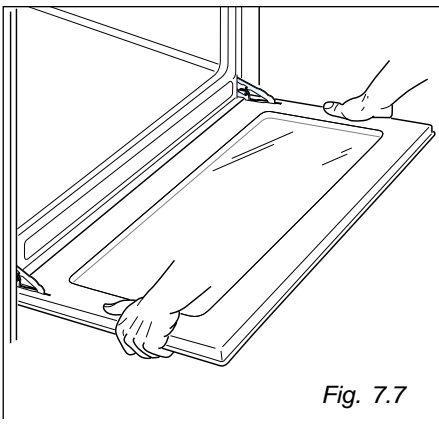
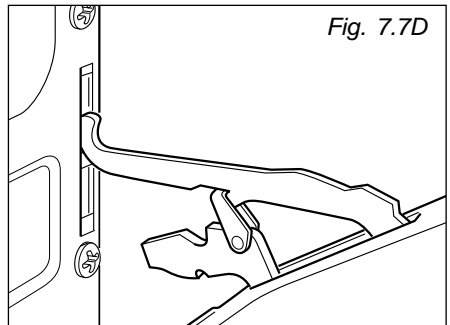
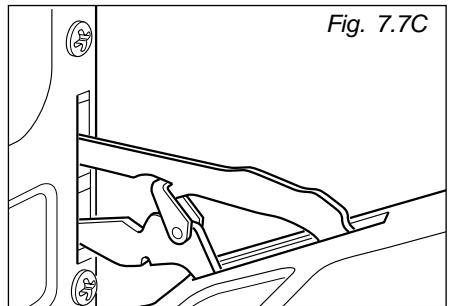
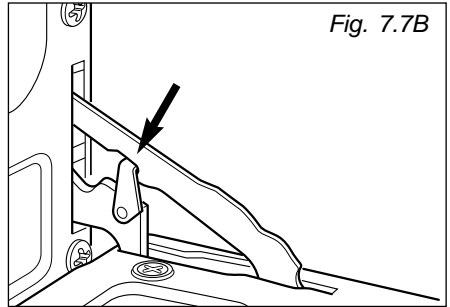
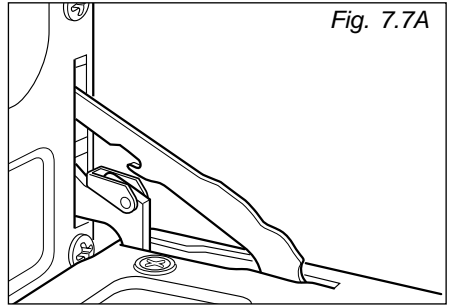

# Helpful Advice

---

## Trouble shooting

### **Problem**

Food too brown but not cooked.

### **Remedy**

Turn down the oven temperature slightly and cook a little longer

### **Problem**

Food cooked but not brown enough.

### **Remedy**

Increase temperature.

### **Problem**

Food baking unevenly.

### **Remedy**

1. The temperature may be slightly high turn it down
2. Position the food in the centre of the shelves rather than towards the sides of the oven.
3. Rotate the food a half turn in the oven.
4. Try pre-heating the oven for 5-15 minutes prior to baking.

Always remove cooked items as soon as they are ready and continue cooking the under-cooked items until they are completely finished.

## Changing the Oven Cavity Light Bulb.

### **If the oven light falls:**

1. Turn off the oven by switching the oven thermostat to “●”, switch off at the cooker point.
2. When the oven is cool, reach back and upwards inside the oven, the bulb is in the top left corner.
3. Unscrew the light glass cover, replace the bulb with a new one of the same specification and screw the cover back until it is hand tight.

**NOTE: Oven bulb replacement is not covered by your guarantee.**

Other bulbs cannot be changed by yourself and should be replaced by an authorised CAPLE Service Engineer.

If you are in any doubt about carrying out these checks, call the **CAPLE Helpline on 0870 241 1142.**

A charge will be made if the appliance is found to be in working order, or if it has not been installed in accordance with these instructions, or if it has been used incorrectly.

## **CAPLE "Built-in" Service**

Should you require service at any time, please contact the **Caple Helpline on 0870 241 1142.**

**Caple** have a nationwide service network of engineers who will respond quickly to your call.

Always replace spare parts with genuine **Caple** spares. These are available from authorised **Caple Service Centres** or by mail order from our **National Service Stores, simply telephone 0870 241 1142.**

When ordering parts always quote the model number and serial number of your appliance.

### **YOUR GUARANTEE**

CAPLE guarantees all parts of this product for one year from the date of purchase. During that time, should it become necessary CAPLE engineers will replace or repair all defective parts free of charge, except for parts subject to fair wear and tear, such as lightbulbs.

Parts and the engineers labour costs are chargeable after the first 12 months.

To qualify for benefits under the guarantee, you must be able to provide proof of date of purchase and the appliance must have been supplied, installed and used for domestic purposes only in accordance with CAPLE instructions.

Consequential losses and accidental damage to the product are not covered by the guarantee.

This guarantee does not affect your statutory or common law rights.

CAPLE cannot be responsible for the results of using this appliance for any other purposes other than those described in these instructions.