



Instruction manual for range cooker

Model code: CR 9227



Contact Caple on 0844 800 3830 or for spare parts www.4caple.co.uk

Thank you for buying your new **Caple** cooker.

To ensure that you get the best results from your new **Caple** cooker, we strongly suggest that you read this instruction manual thoroughly before use.

This manual contains installation advice, cleaning tips and a cooking guide, as well as other important facts about your **Caple** cooker.

If treated with care, your **Caple** appliance should give you years of trouble-free cooking.

For Product Service or Spare Parts
please check contact details at:
www.caple.co.uk

Declaration of **CE** conformity

- This cooker has been designed, constructed and marketed in compliance with:
 - Safety requirements of EU Directive “Low Voltage” 2006/95/EC;
 - Protection requirements of EU Directive “EMC” 2004/108/EC;
 - Requirements of EU Directive 93/68/EEC.
 - Requirements of EU Directive 2011/65/EU.

Important information for correct disposal of the product in accordance with EC directive 2002/96/EC.

At the end of its working life, the product must not be disposed of as urban waste. It must be taken to a special local authority differentiated waste collection centre or to a dealer providing this service.

Disposing of a household appliance separately avoids possible negative consequences for the environment and health deriving from inappropriate disposal and enables the constituent materials to be recovered to obtain significant savings in energy and resources. As a reminder of the need to dispose of household appliances separately, the product is marked with a crossed-out wheeled dustbin.



Important safety precautions and recommendations

IMPORTANT: This appliance is designed and manufactured solely for the cooking of domestic (household) food and is not suitable for any non domestic application and therefore should not be used in a commercial environment.

The appliance guarantee will be void if the appliance is used within a non domestic environment i.e. a semi commercial, commercial or communal environment.

Read the instructions carefully before installing and using the appliance.

- After having unpacked the appliance, check to ensure that it is not damaged and that the oven door closes correctly.
In case of doubt, do not use it and consult your supplier or a professionally qualified technician.
- Packing elements (i.e. plastic bags, polystyrene foam, nails, packing straps, etc.) should not be left around within easy reach of children, as these may cause serious injuries.
- Some appliances are supplied with a protective film on steel and aluminium parts. **This film must be removed before using the appliance.**
- **IMPORTANT:** The use of suitable protective clothing/gloves is recommended when handling or cleaning of this appliance.
- Do not attempt to modify the technical characteristics of the appliance as this may become dangerous to use. The manufacturer declines all responsibility for any inconvenience resulting from the inobservance of this condition.
- Do not operate your appliance by means of an external timer or separate remote-control system.
- Do not carry out cleaning or maintenance operations on the appliance without having previously disconnected it from the electric power supply.
- **WARNING:** Ensure that the appliance is switched off before replacing the oven lamp to avoid the possibility of electric shock.
- Do not use a steam cleaner because the moisture can get into the appliance thus make it unsafe.

- Do not touch the appliance with wet or damp hands (or feet).
- Do not use the appliance whilst in bare feet.
- If you should decide not to use this appliance any longer (or decide to substitute another model), before disposing of it, it is recommended that it be made inoperative in an appropriate manner in accordance to health and environmental protection regulations, ensuring in particular that all potentially hazardous parts be made harmless, especially in relation to children who could play with unused appliances.
- The various components of the appliance are recyclable. Dispose of them in accordance with the regulations in force in your country. If the appliance is to be scrapped, remove the power cord.
- After use, ensure that the knobs are in the off position.
- Children less than 8 years of age shall be kept away unless continuously supervised.
- This appliance can be used by children aged from 8 years and above and persons with reduced physical, sensory or mental capabilities or lack of experience and knowledge if they have been given supervision or instruction concerning use of the appliance in a safe way and understand the hazards involved. Children shall not play with the appliance. Cleaning and user maintenance shall not be made by children without supervision.
- The manufacturer declines all liability for injury to persons or damage to property caused by incorrect or improper use of the appliance.
- **WARNING:** During use the appliance and its accessible parts become hot; they remain hot for some time after use.
 - Care should be taken to avoid touching heating elements (on the hob and inside the oven).
 - The door is hot, use the handle.
 - To avoid burns and scalds, young children should be kept away.
- Make sure that electrical cables connecting other appliances in the proximity of the cooker cannot come into contact with the hob or become entrapped in the oven door.
- **WARNING:** Unattended cooking on a hob with fat or oil can be dangerous and may result in fire. NEVER try to extinguish a fire with water, but switch of the appliance and then cover flame e.g. with a lid or a fire blanket.
- 4 • **WARNING:** Danger of fire: do not store items on the cooking surfaces.

- Do not place or leave empty pans on the glass ceramic hob.
- Do not allow heavy or sharp objects to drop on the glass ceramic hob.
- Do not scratch the hob with sharp objects. Don't use the hob as a work surface.
- **WARNING:** If the hob is cracked or otherwise damaged by falling objects etc., disconnect the appliance from the electrical power supply to avoid the possibility of electric shock and call Customer Service.
- **WARNING:** When correctly installed, your product meets all safety requirements laid down for this type of product category. However special care should be taken around the rear or the underneath of the appliance as these areas are not designed or intended to be touched and may contain sharp or rough edges, that may cause injury.
- **FIRST USE OF THE OVEN** - it is advised to follow these instructions:
 - Furnish the interior of the oven as described at chapter “CLEANING AND MAINTENANCE”.
 - Switch on the empty oven on max to eliminate grease from the heating elements.
 - Disconnect the appliance from the electrical power supply, let the oven cool down and clean the interior of the oven with a cloth soaked in water and neutral detergent; then dry carefully.
- **CAUTION:** Do not use harsh abrasive cleaners or sharp metal scrapers to clean the oven door glass since they can scratch the surface, which may result in shattering of the glass.
- Do not line the oven walls with aluminium foil. Do not place baking trays or the drip tray on the base of the oven chamber.
- **FIRE RISK!** Do not store flammable material in the oven or in the storage compartment.
- Always use oven gloves when removing the shelves and food trays from the oven whilst hot.
- Do not hang towels, dishcloths or other items on the appliance or its handle – as this could be a fire hazard.
- Clean the oven regularly and do not allow fat or oils to build up in the oven base or tray. Remove spillages as soon as they occur.
- Do not stand on the cooker or on the open oven door.
- Always stand back from the appliance when opening the oven door to allow steam and hot air to escape before removing the food.

- **SAFE FOOD HANDLING:** Leave food in the oven for as short a time as possible before and after cooking. This is to avoid contamination by organisms which may cause food poisoning. Take particular care during warmer weather.
- **WARNING:** Taking care NOT to lift the cooker by the door handle.
- **INDUCTION HOBS:**
 - Metallic objects such as knives, forks, spoons and lids should not be placed on the hob surface since they can get hot.
 - Do not use metallic kitchen utensils (e.g. ladles). It is preferable to use plastic or wood kitchen utensils.
 - Please use pans of recommended size (see minimum pan diameter recommended). It is not advisable to use pans smaller than the cooking zone. The pans have to be placed in the centre of the cooking zone.
 - Do not use defective pans or pans with a curved bottom.
 - Please use suitable pans marked for induction cooking.
 - Please keep your distance from the electromagnetic fields by standing 5-10 cm from the cooking zones. When possible use the rear cooking zones.
 - Magnetic objects (e.g. credit cards, floppy disks, memory cards) and electronic instruments (e.g. computers) should not be placed near the induction hob.
 - The heating of magnetic tins is forbidden! Close tins may explode by exceeding pressure while heating. There is a burning risk with open tins as well, because the integrated temperature protection can't work well.
 - **IMPORTANT WARNING:** The induction hob complies with European Standards for domestic cooking appliances. Therefore it should not interfere with other electronic units. Persons with cardiac pacemakers or any other electrical implants must check with their doctor if they can use an induction cooking system (and check any possible interferences with the implants).

1 - Electrical Requirements

**WARNING!
ELECTRICITY CAN BE EXTREMELY DANGEROUS.
THIS APPLIANCE MUST BE EARTHED.**

For your safety please read the following information:

This appliance must be installed by a qualified technician according with the current local regulations and in compliance with the manufacturer instructions.

The appliance must be connected to the electrical network verifying above all that the voltage corresponds to the value indicated on the specifications plate and that the cables section of the electrical plant can bear the load which is also indicated on the plate.

The cooker must be connected directly to the mains placing an omnipolar switch with minimum opening between the contacts of 3 mm between the appliance and the mains.

The power supply cable must not touch the hot parts and must be positioned so that it does not exceed 75°C at any point.

Once the cooker has been installed, the switch must always be accessible.

**The connection of the appliance to earth is mandatory.
The manufacturer declines all responsibility for any inconvenience resulting from the inobservance of this condition.**

Electrical Installation - Wall box connection

This appliance must be connected to a double pole isolating switch (fig. 1.1) and to the terminal block in the cooker (figs. 1.2, 1.3 & 1.4) using the following guide:

- 1) The wire which is coloured brown must be connected to the terminal marked **L** (Live), or coloured Red.
- 2) The wire which is coloured blue must be connected to the terminal marked **N** (Neutral), or coloured Black.
- 3) The wire which is coloured green and yellow must be connected to the terminal marked **E** (Earth) \equiv or coloured Green.

IMPORTANT: These connections must be carried out by a qualified electrical engineer.

IMPORTANT: This cooker must be connected to a suitable double pole control unit adjacent to the cooker.

NO DIVERSITY CAN BE APPLIED TO THIS CONTROL UNIT.

IMPORTANT:
This appliance must be earthed.

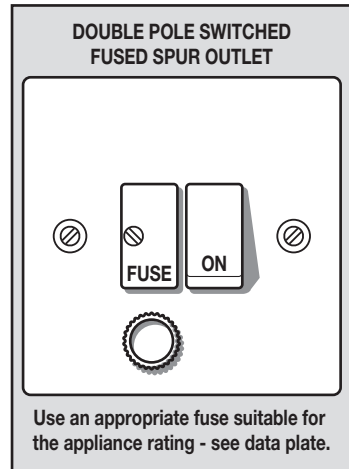

Fig. 1.1

Connecting the feeder cable

To connect the feeder cable to the cooker it is necessary to:

- Remove the two screws that hold shield **A** behind the cooker.
- Open completely the cable clamp **D**.
- Insert the mains cable (type H05RR-F or H05VV-F) of minimum 6 mm² section into the cable clamp **D**.
- Connect the phase and earth cables to terminal **B** according to figure 1.3 and 1.4.
- Pull the feeder cable and block it with the cable clamp **D**.
- Re-mount shield **A**.

N.B. The earth conductor must be left about 3 cm longer than the others.

Feeder cable section “Type H05RR-F or H05VV-F”

230V~

3 x 6 mm² (**)

- (**) – Connection with wall box connection.
- Diversity factor applied.
 - A diversity factor may be applied to the total loading of the cooker only by a suitable qualified person.

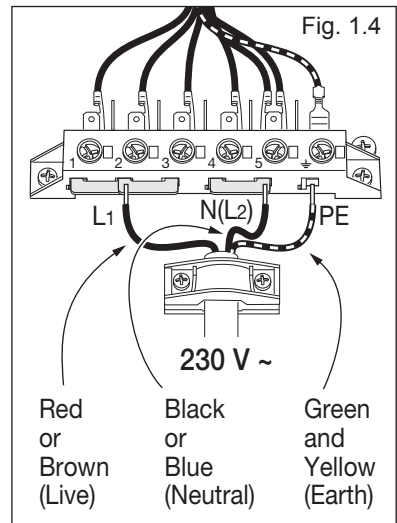
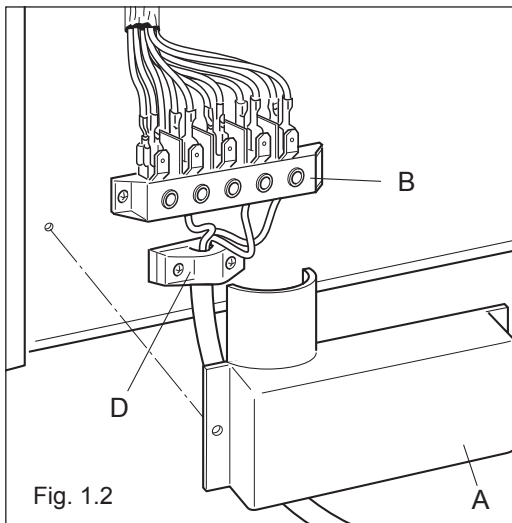
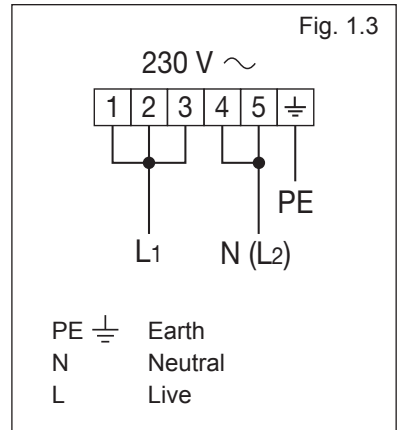

FOR THE INSTALLER

2 - Location

– The appliance should be installed by a qualified electrician in compliance with the laws in force in your country and in observation of the instructions supplied by the manufacturer.

Failure to comply with this condition will render the guarantee invalid.

– Always disconnect the cooker from mains power supply before carrying out any maintenance operations or repairs.

The cooker must be installed no less than 50 mm away from any side wall which exceed the height of the cooktop.

If the cooker is located on a pedestal it is necessary to provide safety measures to prevent falling out.

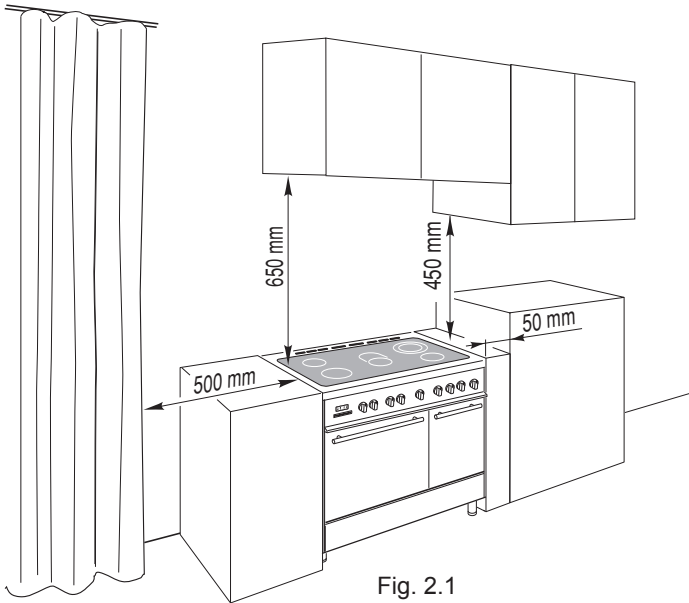

Fig. 2.1

The appliance must be housed in heat resistant units. The walls of the units must be capable of resisting temperatures of 75 °C above room temperature. Do not install the appliance near inflammable materials (eg. curtains).

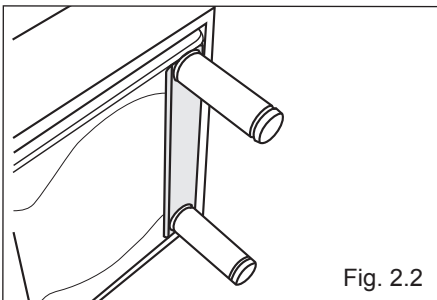

Fig. 2.2

Fitting the adjustable feet

The adjustable feet must be fitted to the base of the cooker before use.

Rest the rear of the cooker on a piece of the polystyrene packaging exposing the base for the fitting of the feet.

Fit the 4 legs by screwing them tight into the support base as shown in picture 2.2.

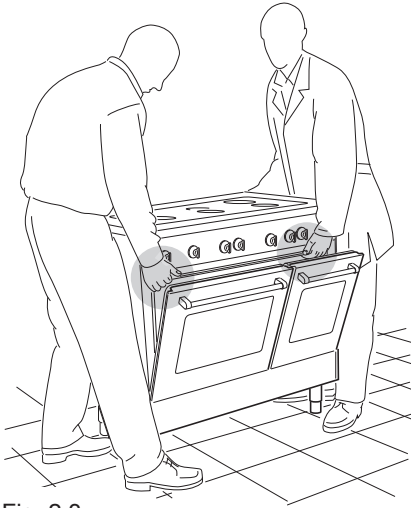

Fig. 2.3

Moving the cooker

WARNING

When raising cooker to upright position always ensure two people carry out this manoeuvre to prevent damage to the adjustable feet (fig. 2.3).

WARNING

Be careful: do not lift the cooker by the door handle when raising to the upright position (fig. 2.4).

WARNING

When moving cooker to its final position **DO NOT DRAG** (fig. 2.5). Lift feet clear of floor (fig. 2.3).

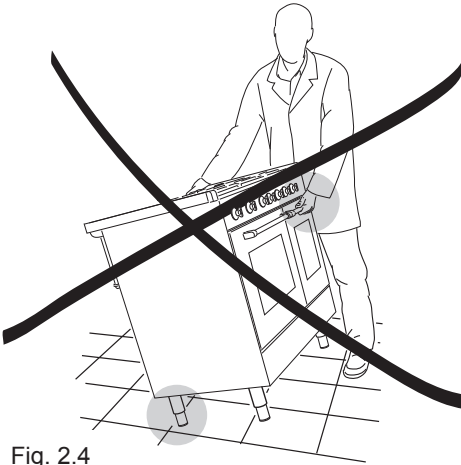

Fig. 2.4

Levelling the cooker

The cooker may be levelled by screwing the lower ends of the feet IN or OUT (fig. 2.6).

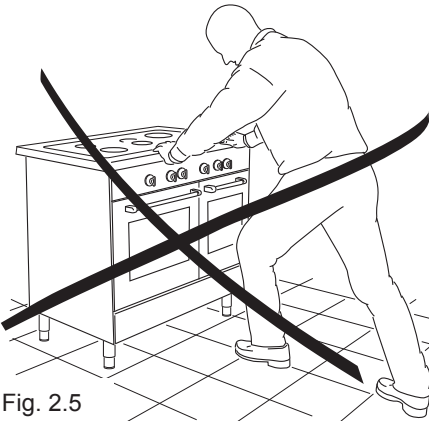

Fig. 2.5

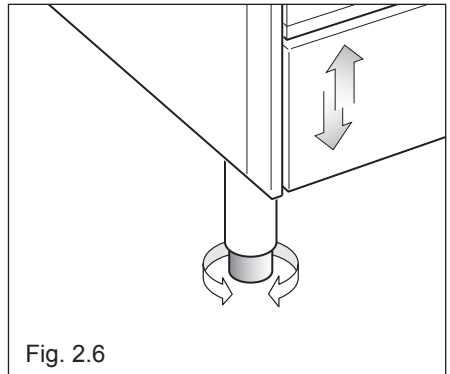

Fig. 2.6

Anti-Tilt Bracket

Important!

To restrain the appliance and prevent it tipping accidentally, fit a bracket to its rear to fix it securely to the wall.

To fit the anti-tilt bracket:

1. After you have located where the cooker is to be positioned, mark on the wall the place where the two screws of the anti-tilt bracket have to be fitted.
Please follow the indications given in fig. 2.7.
2. Drill two 8 mm diameter holes in the wall and insert the plastic plugs supplied.

Important!

Before drilling the holes, check that you will not damage any pipes or electrical wires.

3. Loosely attach the anti-tilt bracket with the two screws supplied.
4. Move the cooker to the wall and adjust the height of the anti-tilt bracket so that it can engage in the slot on the cooker's back, as shown in fig. 2.7.
5. Tighten the screws attaching the anti-tilt bracket.
6. Push the cooker against the wall so that the anti-tilt bracket is fully inserted in the slot on the cooker's back.

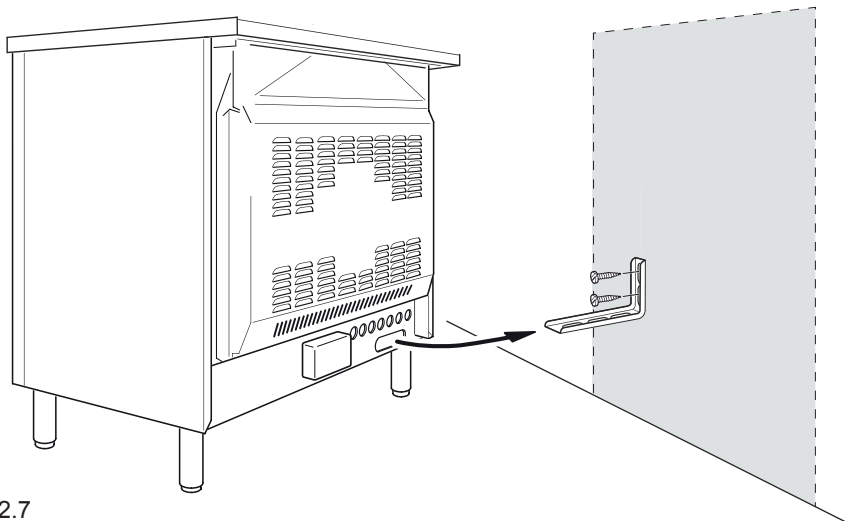

12 Fig. 2.7

3 - Features and Technical Data



Fig. 3.1

Vitroc ceramic cooking hob - (Fig. 3.1)

- | | | |
|--|-------------|-------------|
| 1. 3 circuit radiant cooking zone | Ø 180 | 1700 W |
| 2. 3 circuit radiant cooking zone | Ø 145 | 1200 W |
| 3. Oval cooking zone | Ø 140 x 250 | 1800/1000 W |
| 4. Double cooking zone | Ø 210/120 | 2100/700 W |
| 5. 3 circuit radiant cooking zone | Ø 145 | 1200 W |
| 6. Cooking zone residual heat indicators | | |

NOTE

When the hob temperature is above 60 °C, the corresponding indicator light 6 (Fig. 3.1) will come on to indicate that the hob is hot.

Attention: Do not use the ceramic hob if the glass surface is broken or cracked in any way. Please disconnect the appliance from the mains and contact the After-Sales service.

Control Panel

Fig. 3.2

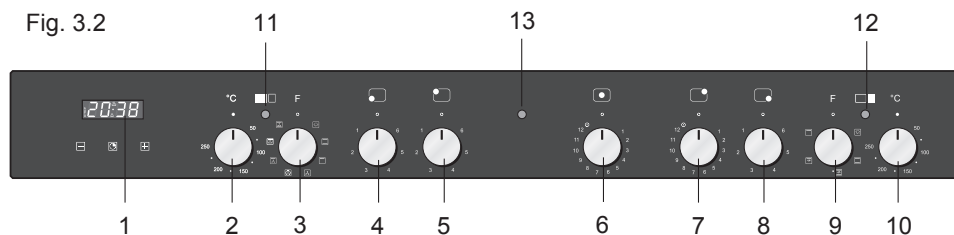

Control panel - Controls description - (Fig. 3.2)

1. Clock and timer with “Touch-Control” keys (main oven only)
2. Multifunction main oven thermostat knob (left oven)
3. Multifunction main oven switch knob (left oven)
4. Front left cooking zone control knob
5. Rear left cooking zone control knob
6. Central cooking zone control knob
7. Rear right cooking zone control knob
8. Front right cooking zone control knob
9. Conventional oven switch knob (right oven)
10. Conventional oven thermostat knob (right oven)

Pilot lamps:

11. Main oven thermostat indicator light (left oven)
12. Conventional oven thermostat indicator light (right oven)
13. Ceramic hob ON indicator light

Please note: This appliance incorporates a safety cooling fan which you will hear operating whenever the oven or grill are in use. This fan is to reduce the external temperature of the appliance and cool the internal components.

How To Use the Cooking Hob

The ceramic surface of the hob allows a fast transmission of heat in the vertical direction, from the heating elements underneath the ceramic glass to the pans set on it.

The heat does not spread in the horizontal direction, so that the glass stays “cool” at only a few centimeters from the cooking plate.

The 5 cooking zones are shown by painted disks on the ceramic surface.

IMPORTANT NOTE:

The heating elements incorporate a thermolimiter that switches the element ON/OFF during all the settings to protect the ceramic glass from overheating. The use of incorrect pans and/or wrong pan positioning will cause the temperature limiter to operate more frequently, resulting in a reduction of cooking performance.

3 circuit radiant zones

Incorporating 3 heating elements (fig. 3.4) you can control and light up all together or separately by a 6 position switch (fig. 3.3).

Reaches the working temperature in a very short time.

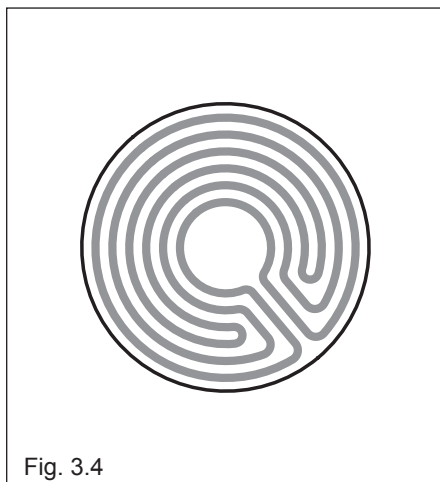



Double and oval radiant zones

The heating element is formed of a coil of resistant material which reaches the working temperature quickly. Operation of the cooking zone is controlled by a continuous energy regulator from 1 to 12 (maximum temperature) (fig. 3.5).

To turn on **both zones of the double element**, turn the double element knob fully clockwise to the position .

To reduce the heat of the full double element, turn its knob anticlockwise to setting 12 or lower. Adjust the heat during cooking as necessary.

Note: if you leave the knob at the  position, the full double element will remain at the highest heat setting.

To **return to using only the inner zone of the double element**, first turn the knob to the  (off) position (you should feel a click) and then clockwise to a setting from 1 to 12.

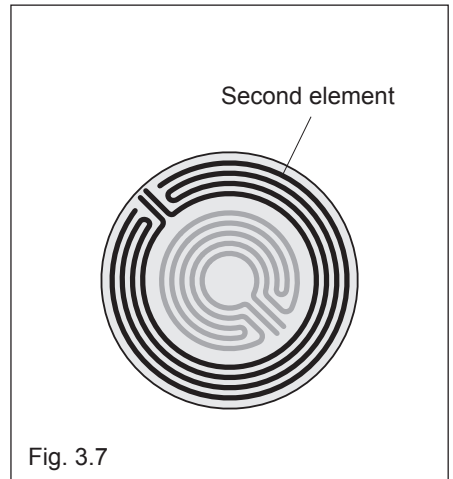
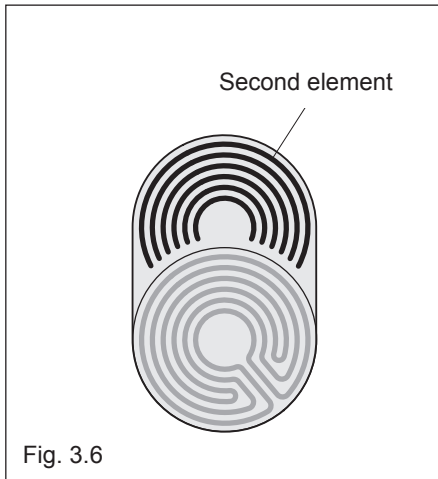

Cooking hints

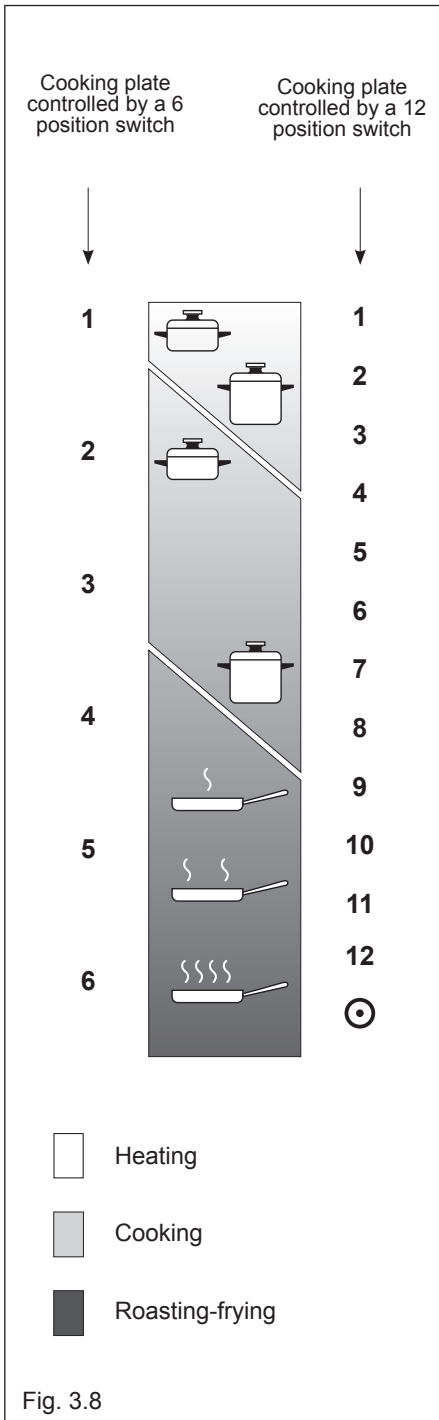

Fig. 3.8

Knob setting		Type of cooking
0	0	Switched OFF
1	1	For melting operations (butter, chocolate).
2	2	
2	2 3 4	To keep food hot and to heat small quantities of liquid (sauces, eggs).
3	4 5 6	To heat bigger quantities; to whip creams and sauces. (vegetables, fruits, soups).
3 4	6 7	Slow boiling, i.e.: boiled meats, spaghetti, soups, continuous steam cooking of roasts, stews, potatoes.
4	7 8	For every kind of frying, cutlets, uncovered cooking, i.e.: risotto.
4 5	8 9 10	Browning of meats, roasted potatoes, fried fish, omelettes, and for boiling large quantities of water.
6	11 12	Fast frying, grilled steaks, etc.
	⊙	Switching on the second element (Double and oval radiant plate only)

After a short period of use, experience will teach you which setting is the right one for your needs.

Residual heat indicator

The hob also features 5 warning lights which are connected to the corresponding plates.

When the temperature of a cooking plate is above 60 °C, the relevant warning light will also light up to warn of heat on the surface of the hob.

This light also stay on after the cooking plate has been switched off to show that the hob surface is still hot.

This residual heat will lasts for a long time after the cooking plate has been switched off.

During this time you should avoid touching the hob surface over the cooking area.

Please pay special attention to ensure that children are not allowed near the hob.

The light will switch off automatically as soon as the surface temperature of the cooking plate falls below 60°C.

Caution!

The cooker becomes very hot during operation.

Keep children well out of reach.

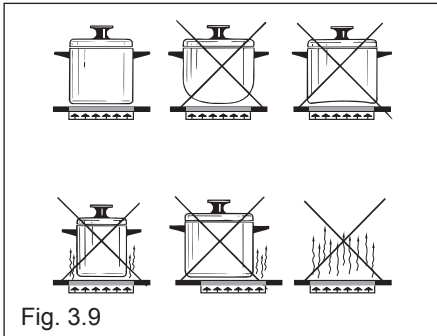

**DO NOT USE GLASSWARE ON CERAMIC HOBS.
DO NOT USE PANS WITH ROUGH CIRCULAR
MACHINED BASE.**

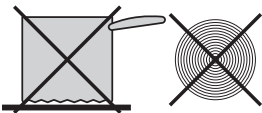

Cooking hints:

– To reduce the cooking time, you can turn the control knob to the max when you switch the plate on.

After a short time you can set the control knob to the position required for cooking.

– You should only use pots and pans with flat bases (pans with the test mark for glass-ceramic hobs are available from specialist shops).

The diameter of the pan should match that of the cooking plate (or be slightly bigger) to make the most of the energy.

– Since the cooking surface will stays hot for a certain time after the plate has been switched off, you can switch it off 5 or 10 minutes before the end of the cooking.

The residual heat of the hob will complete the cooking.

– To save electricity, use pan lids whenever possible.

– Never cook the food directly on the glass ceramic hob, but in special pans or containers.

– **Do not scratch the cooktop with cutting or sharp objects.**

Do not use the glass ceramic surface as a work surface.

DEEP FAT FRYING

For safety purposes when deep fat frying, do not fill the pan more than one third full of oil.

DO NOT cover the pan with a lid and **DO NOT** leave the pan unattended.

In the unfortunate event of a fire, leave the pan where it is and turn off the control knobs.

Place a damp cloth or lid over the pan to smother the flames. Leave the pan to cool for at least 30minutes before moving the pan.

DO NOT USE WATER ON THE FIRE.

Safety hints:

- Before you switch the hob on, make sure you know which knob controls the required cooking plate. We advise you to set the pan over the cooking plate before switching it on. Remove the pan after you have switched the cooking plate off.
- Do not use pots and pans with rough bases (pay attention to cookware made of cast-iron). Rough bases can damage (scratch) the glass surface of the hob. Make sure that the pan bottom of the pan is dry and clean.
- Pots with aluminium bottoms may leave silver streaks or spots on the hob.
- Do not leave wet or damp lids on the hob.
- The glass-ceramic surface and pans must be clean. Carefully remove any food debris (especially containing sugar), dirt etc. with the aid of a cleansing agent.
- Pan handles should never stand out beyond the kitchen worktop, as there is a great danger of knocking the pan over.
This will also ensure that children cannot reach them.
- **Do not use the hob if the glass surface is broken or cracked in any way. Please disconnect the hob from the mains and contact the after-sales service.**
- Do not lean over the cooking plate when in use.
- Do not lay cooking foil or plastic materials on the ceramic surface when it is hot.
- Remember that the surface remains hot for a long time (about 30 min.) after the cooking plate has been switched off.
- Follow the cleaning instructions carefully.

Do not use the glass surface for storage.

Cleaning the hob

Before you begin cleaning make sure that the appliance is switched off.

Remove spillages and other types of incrustations.

Dust or food particles can be removed with a damp cloth.

If you use a detergent, please make sure that it is not abrasive or scouring. Abrasive or scouring powders can damage the glass surface of the hob.

All traces of the cleaner must be removed with a damp cloth.

Do not put articles on the hob which can melt: i.e plastic, aluminium foil, sugar, sugar syrup mixtures etc.

If any of these products items have melted on the ceramic surface, you should remove it immediately (when the surface is still hot) by using a scraper to avoid any permanent damage to the surface of the hob.

Avoid using a knife or other sharp utensils since these can damage the ceramic.

Do not use steel wool or an abrasive sponge which could scratch the surface permanently.

ATTENTION: MOST IMPORTANT!

If cleaning the glass ceramic hob using a special scraper tool take extra care to avoid damaging to the seal at the edges of the glass ceramic surface.

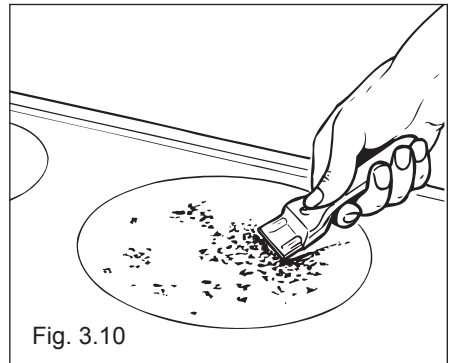





Fig. 3.10

4 - Clock and timer with “Touch-Control” keys

(left main oven only)



keys

 and  Touched simultaneously
(for more than 2 seconds):

- setting the clock;
- setting the timer volume (by touching once, along with the  key);
- to cancel automatic cooking at any time.



Function selection (touched for more than 2 seconds):

- setting the clock (only after first connection or after a power failure);
- timer;
- automatic cooking “*dur*” (duration) - how long the food will take to cook (by touching the  key again);
- automatic cooking “*End*” - the time you would like the oven turns off (by touching the  key two more times);



Increases the number shown on the display



Decreases the number shown on the display



Fig. 4.1

Illuminated symbols:

AUTO *flashing* - automatic cooking completed, oven in automatic position but not set

AUTO *steady illumination* - oven set for automatic cooking, cooking still not taking place

 *flashing* - timer being set

 *steady illumination* - timer in operation

 *steady illumination* - oven set for manual cooking

 and **AUTO** *AUTO flashing* - automatic cooking being set



 and **AUTO** *steady illumination* - oven set for automatic cooking, cooking taking place.

“TOUCH-CONTROL” keys



The “touch-control” keys shall be operated by the fingers (just by touching the key). When using touch controls it is best to use the ball of your finger rather than the tip.

The keys are automatically deactivated:





- 8 seconds after the last selection; the deactivation is indicated by an acoustic signal (“beep”).

To reactivate just touch the “” key or the “” and “” keys (simultaneously) for more than 2 seconds.

Setting the clock

When first connected, or after a power failure, the digits and “**AUTO**” will shown on the display. To set the clock, touch the “” key, for more than 2 seconds, and then the “” or “” keys.

Important: the oven does not operate, in manual cooking, without first having set the clock.

To set the clock, with the appliance already connected, touch the “” and “” keys simultaneously (for more than 2 seconds), then “” or “” keys.

Important:







- **changing the time will delete any automatic program;**
- **after setting the clock, the oven starts to operate in the selected function (manual cooking). The “” symbol is steady illuminated.**





Using the timer

You can use the timer at any time, even when the oven is not in use.

The timer does not turn the oven off.

The timer can be set for up to 23 hours and 59 minutes.

- To set the timer, touch the “” key for more than 2 seconds (the “” symbol flashes), than the “” or “” keys.
- After about 8 seconds an acoustic signal (“beep”) will sound confirming the regulation (“” symbol steady illuminated).
- To check the remaining time touch the “” key for more than 2 seconds. If the remaining time is more than a minute the display will show hours and minutes; if less than a minute the display will show seconds.
- When the time is up, the timer will beep.

Touch the touch the “” key, for more then 2 seconds, to turn it off; or press the “” or “” key to stop the beep and than the “” key, for more than 2 seconds, to deactivate the “” symbol flashing on the display.

- Turn off the oven manually (function and thermostat knobs in the off position) if the manual cooking has been completed.

Setting the timer volume

You can select from three volume levels.

- Touch the “+” and “-” keys simultaneously for more than 2 seconds.
- Touch the “🔊” key; you can read on the display the current timer volume (“*ton1*”, “*ton2*” or “*ton3*”).
- Touch the “-” key to listen or change the timer volume.
- Timer volume activated: the last displayed.
- After about 8 seconds an acoustic signal (“*beep*”) will sound confirming the volume setting; then the time of day will be displayed.

Automatic cooking

Use automatic cooking to automatically turn the oven on, cook, and then turn the oven off.

1. Check the clock shows the correct time.
2. Select the function and temperature (function and temperature knobs). The oven will come on.
3. Decide how long the food will take to cook, allowing time for preheating if necessary.
4. Touch the “🔊” key for more than 2 seconds and then touch again. “*dur*” will show (duration). Using the “+” and “-” keys, set the cooking time.
5. Decide the time you would like the oven to turn off; touch the “🔊” key for more than 2 seconds and then touch it two times again. “*End*” will show. Using the “+” and “-” keys, set the cooking time.

Note: while “*dur*” is displayed you can change to “*End*” just by touching one time the “🔊” key (within 8 seconds from the last selection).

If there is time to wait before cooking starts, the current time of day and “**AUTO**” will show in the clock display. The oven will switch off but is now set for automatic cooking. If you are already at home to turn the oven on and only want the oven to turn off automatically, start cooking as normal, then follow step 4 or step 5 to set a time to stop the oven.

When automatic cooking starts, “🔥” will be displayed and the oven will turn on.

- To see the remaining cook time, follow step 4 up to display “*dur*” (duration).
- To see the set stop time, follow step 5 up to display “*End*”.
- To cancel automatic cooking at any time, touch the “+” and “-” keys simultaneously (for more than 2 seconds) and turn the temperature and function knobs to the off position.

When the stop time is reached, the oven will turn off, the timer will beep and “**AUTO**” will flash:

- Touch any key to stop the beeping.
- Touch the “🔊” key, for more than 2 seconds, to return the oven to the manual mode (“🔥” symbol steady illuminated on the display).
- Turn the temperature and function knobs to the off position.

Attention: after a power failure any automatic program is deleted. Turn off the oven manually.

6 - Multifunction main oven (left oven)

Attention: the oven door becomes very hot during operation. Keep children away.



General features

As its name indicates, this is an oven that presents particular features from an operational point of view.

In fact, it is possible to insert 7 different programs to satisfy every cooking need. The 7 positions, thermostatically controlled, are obtained by 4 heating elements which are:

- Bottom element 1200 W
- Top element 1000 W
- Grill element 2000 W
- Circular element 2200 W

Note:

Upon first use, it is advisable to operate the oven for 30 minutes in the position  and for another 30 minutes at the maximum temperature (thermostat knob on position 250) in the positions  and , to eliminate possible traces of grease on the heating elements.

Clean the oven and accessories with warm water and washing-up liquid.

WARNING:

The door is hot, use the handle.

During use the appliance becomes hot. Care should be taken to avoid touching heating elements inside the oven.

OPERATING PRINCIPLES

Heating and cooking in the MULTI-FUNCTION oven are obtained in the following ways:

a. by normal convection

The heat is produced by the upper and lower heating elements.

b. by forced convection

A fan sucks in the air contained in the oven muffle, which sends it through the circular heating element and then sends it back through the muffle. Before the hot air is sucked back again by the fan to repeat the described cycle, it envelops the food in the oven, provoking a complete and rapid cooking.

It is possible to cook several dishes simultaneously.

c. by semi-forced convection

The heat produced by the upper and lower heating elements is distributed throughout the oven by the fan.

d. by radiation

The heat is irradiated by the infra red grill element.

e. by radiation and ventilation

The irradiated heat from the infra red grill element is distributed throughout the oven by the fan.

f. by ventilation

The food is defrosted by using the fan only function without heat.

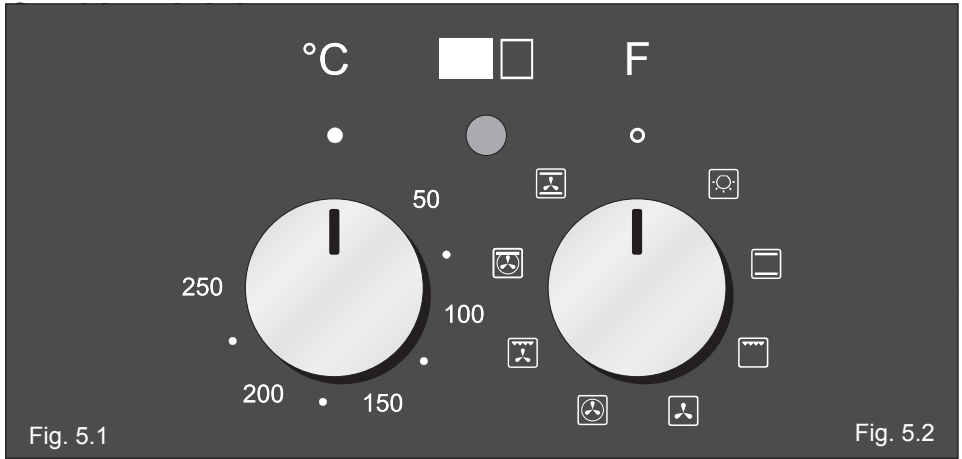

Thermostat knob (fig. 5.1)

This only sets the cooking temperature and does not switch the oven on. Rotate clockwise until the required temperature is reached (**from 50 to 250°C**). The oven thermostat indicator light will illuminate when the oven is switched on and turns off when the oven reaches the correct temperature. The light will cycle on and off during cooking.

Function selector knob (fig. 5.2)

Rotate the knob clockwise to set the oven for one of the following functions:



Oven light

By setting the knob to this position, only the oven light comes on. It remains on in all the cooking modes.



Traditional convection cooking

The upper and lower heating elements are switched on. The heat is diffused by natural convection and the temperature must be regulated between 50° C and 250° C with the thermostat knob.

It is necessary to preheat the oven before introducing the foods to be cooked.

Recommended for:

For foods which require the same cooking temperature both internally and externally, i. e. roasts, spare ribs, meringue, etc.



Grilling

The infra-red heating element is switched on. The heat is diffused by radiation. Use with the **oven door closed** and the thermostat knob to between **50°** and **225°C** for **max 15** minutes, then to position **175°C**.

Note: It is recommended that you do not grill for longer than 30 minutes at any one time.

Attention: the oven door becomes very hot during operation. Keep children away. For correct use see chapter "USE OF THE GRILL".

Recommended for:

Intense grilling action for cooking with a broiler; browning, crisping, "au gratin", toasting, etc.



Defrosting frozen foods

Only the oven fan is on.

To be used with the thermostat knob on "●" because the other positions have no effect. The defrosting is done by simple ventilation without heat.

Recommended for:

To rapidly defrost frozen foods; 1 kilogram requires about one hour.

The defrosting times vary according to the quantity and type of foods to be defrosted.



Hot air cooking

The circular element and the fan are on.

The heat is diffused by forced convection and the temperature must be regulated between 50° and 250 °C with the thermostat knob.

It is not necessary to preheat the oven.

Recommended for:

For foods that must be well done on the outside and tender or rare on the inside, i. e. lasagna, lamb, roast beef, whole fish, etc.



Ventilated grill cooking

The infra-red ray grill and the fan are on.

The heat is mainly diffused by radiation and the fan then distributes it throughout the oven. The temperature must be regulated between 50° and 175 °C **for max 30 minutes**, with the thermostat knob.

It is necessary to preheat the oven for about 5 minutes.

Use with the oven door closed.

Attention: the oven door becomes very hot during operation.

Keep children away.

For correct use see chapter “GRILLING AND “AU GRATIN”.

Recommended for:

For grill cooking when a fast outside browning is necessary to keep the juices in, i. e. veal steak, steak, hamburger, etc.



Maintaining temperature after cooking or slowly heating foods

The upper element and the circular element connected in series, are switched on; also the fan is on.

The heat is diffused by forced convection with the most heat being produced by the upper element.

The temperature must be regulated between 50° and 140 °C with the thermostat knob.

Recommended for:

To keep foods hot after cooking. To slowly heat already cooked foods.



Convection cooking with ventilation

The upper and lower heating elements and the fan turn on.

The heat coming from the top and bottom is diffused by forced convection.

The temperature must be regulated between 50° and 250 °C with the thermostat knob.

Recommended for:

For foods of large volume and quantity which require the same internal and external degree of cooking; for ie: rolled roasts, turkey, legs, cakes, etc.

Cooking Advice

Sterilization

Sterilization of foods to be conserved, in full and hermetically sealed jars, is done in the following way:

- a. Set the switch to position .
- b. Set the thermostat knob to position 185 °C and preheat the oven.
- c. Fill the dripping pan with hot water.
- d. Set the jars onto the dripping pan making sure they do not touch each other and the door and set the thermostat knob to position 135 °C.

When sterilization has begun, that is, when the contents of the jars start to bubble, turn off the oven and let cool.

Regeneration

Set the switch to position  and the thermostat knob to position 150° C. Bread becomes fragrant again if wet with a few drops of water and put into the oven for about 10 minutes at the highest temperature.

Roasting

To obtain classical roasting, it is necessary to remember:

- that it is advisable to maintain a temperature between 180 and 200 °C.
- that the cooking time depends on the quantity and the type of foods.

Grilling and “au gratin”

Set the switch to position . Set the thermostat to position 175 °C and after having preheated the oven, simply place the food on the shelf.

Close the door and let the oven operate with the thermostat on, until grilling is complete. Adding a few dabs of butter before the end of the cooking time gives the golden “au gratin” effect.

Note: It is recommended that you do not grill for longer than 30 minutes at any one time.

ATTENTION: the oven door becomes very hot during operation. Keep children away.

Simultaneous cooking of different foods

The MULTI-FUNCTION oven set on position  and  gives simultaneous heterogeneous cooking of different foods.

Different foods such as fish, cake and meat can be cooked together without mixing the smells and flavours.

This is possible since the fats and vapors are oxidized while passing through the electrical element and therefore are not deposited onto the foods.

The only precautions to follow are:

- The cooking temperatures of the different foods must be as close to as possible, with a maximum difference of 20° - 25 °C.
- The introduction of the different dishes in the oven must be done at different times in relation to the cooking times of each one.

The time and energy saved with this type of cooking is obvious.

Use of the grill

Preheat the oven for about 5 minutes.

Introduce the food to be cooked, positioning the rack as close to the grill as possible.

The drip pan should be placed under the rack to catch the cooking juices and fats.

Grilling with the oven door closed.

Do not grill for longer than 30 minutes at any one time.

Caution: the oven door becomes very hot during operation.

Keep children well out of reach.

Oven cooking

Before introducing the food, preheat the oven to the desired temperature.

For a correct preheating operation, it is advisable to remove the tray from the oven and introduce it together with the food, when the oven has reached the desired temperature.

Check the cooking time and turn off the oven 5 minutes before the theoretical time to recuperate the stored heat.



6 - Conventional oven (right oven)

General features

The conventional oven is provided with 3 heating elements which are:

- Top element 643 W
- Bottom element 735 W
- Grill element 1332 W

NOTE:

Upon first use, it is advisable to operate the oven for 30 minutes in the position  and for another 30 minutes at the maximum temperature (thermostat knob on position 250) in the position  to eliminate possible traces of grease on the heating elements.

Operating principles

Heating and cooking in the CONVENTIONAL oven are obtained in the following ways:

a. by natural convection

The heat is produced by the upper and lower heating elements.

b. by radiation

The heat is radiated by the infra red grill element.

WARNING:

The door is hot, use the handle.

During use the appliance becomes hot. Care should be taken to avoid touching heating elements inside the oven.

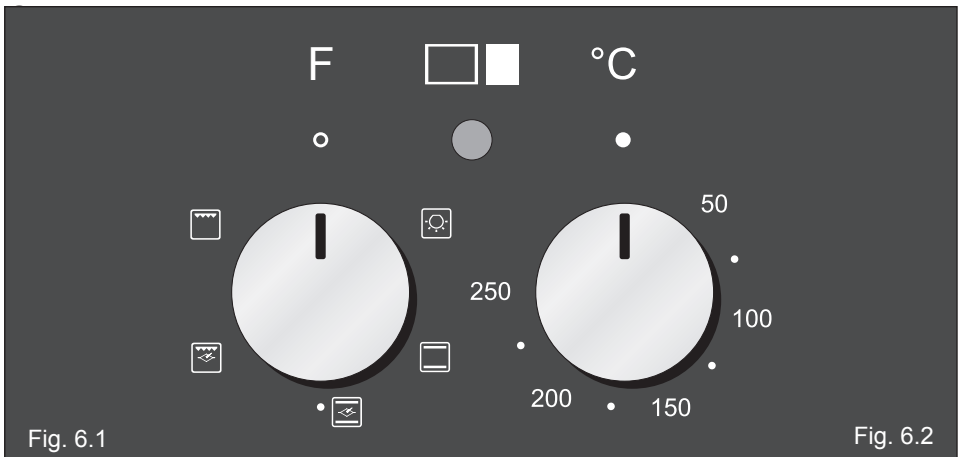

Fig. 6.1

Fig. 6.2

Thermostat knob (fig. 6.2)

This only sets the cooking temperature and does not switch the oven on. Rotate clockwise until the required temperature is reached (**from 50 to 250°C**).

The oven thermostat indicator light will illuminate when the oven is switched on and turns off when the oven reaches the correct temperature.

The light will cycle on and off during cooking.

Function selector knob (fig. 6.1)

Rotate the knob clockwise to set the oven for one of the following functions.



Oven light

By setting the knob to this position, only the oven light comes on. It remains on in all the cooking modes.



Traditional convection cooking

The upper and lower heating elements come on.

The heat is dispersed by natural convection and the temperature must be set to between 50° and 250°C via the thermostat knob. The oven must be preheated before cooking.

In the  position the rotisserie motor come on for cooking with the rotisserie.

Recommended for:

Food that requires the same degree of cooking both inside and out, for example roasts, spare pork ribs, meringues etc.



Traditional grilling

The infrared electrical resistance comes on.

The heat is diffused by radiation.

Use with the oven door **closed** and the thermostat knob to position 225°C for 15 minutes then to 175°C.

In the  position the rotisserie motor come on for cooking with the rotisserie.

For cooking hints, see the chapter “**USE OF THE GRILL**”.

Recommended for:

Intense grilling, browning, cooking au gratin and toasting etc.

It is recommended that you do not grill for longer than 30 minutes at any one time.

Attention: the oven door becomes very hot during operation.

Keep children away.

Use of the grill

Switch the grill on, setting the two knobs:

- Function selector to  or  position.
- Thermostat selector to position **225°C** for 15 minutes then to **175°C**.

Leave to warm up for approximately 5 minutes with the door **closed**.

Place the food inside positioning the rack as near as possible to the grill.

Insert the drip pan under the rack to collect the cooking juices.

Grilling with the oven door closed and do not for longer than 30 minutes at any one time.

Attention: the oven door becomes very hot during operation.

Keep children away.

Rotisserie

The oven is equipped with a rotisserie.

This device is made up of:

- an electrical motor mounted on the rear part of the oven
- a stainless steel rod, equipped with a detachable athermic grip and 2 recordable forks
- a rod support to be inserted into the central rack holders of the oven.

Use of the rotisserie

- Insert the dripping pan into the lowest rack holders of the oven and insert the rod support into the intermediate rack holders.
- Put the meat to be cooked onto the rod, being careful to secure it in the center with the special forks.
- Insert the rod into the motor opening and rest it onto the support of the spit collar; then remove the grip by turning it to the left.

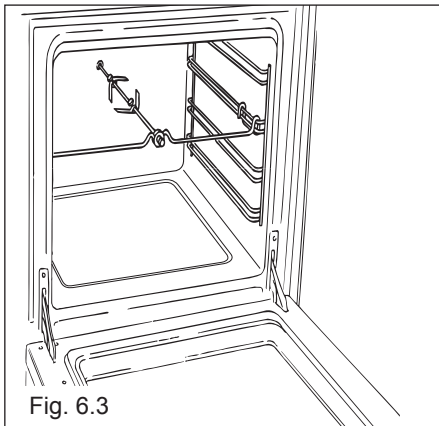

Fig. 6.3

The rotation direction of the rotisserie can be either clockwise or counter-clockwise.

Recommended cooking temperature

Food	°C	°F	Gas Mark	Shelf Position*	Cooking Time (approx)
CAKES					
Victoria sandwich	190	375	5	2 or 3	20-25 mins
Small cakes/buns	190	375	5	1 and 2	15-20 mins
Maidera cake	180	350	4	2 or 3	20 mins
Fruit cake	170	325	3	3	1¼ hours
Rich fruit cake	150	300	2	3 or 4	2½ hours
Scones	225	425	8-9	2	8-10 mins
PASTRY					
Puff	225	425	8-9	2	10-20 mins
Short crust	200	400	6	2	20-30 mins
Plate tarts	200-210	400-410	6	1 or 2	30-35 mins
Quiches and flans	200-210	400-410	6	1 or 2	40-45 mins
YEAST					
Bread loaf	225	425	7-8	2	35-55 mins
Bread rolls	220	425	7	1 or 2	15-20 mins
Pizza dough	230	450	8	2	20 mins
ROAST MEAT					
Beef – Medium	190	375	5	2 or 3	20 mins/lb + 20 mins
Lamb	190	375	5	2 or 3	25-30 mins/b + 25 mins
Pork	190-200	375-400	5-7	2 or 3	30 mins/lb + 30 mins
Veal	190	375	5	2 or 3	30 mins/b + 30 mins
Chicken	190	375	5	2 or 3	30 mins/b + 30 mins
Turkey up to 10lb	180	350	4	2 or 3	18-20 mins/b + 20 mins
Stews/casseroles	150-170	300-325	2-3	2 or 3	1½ 2 hours

N.B. For fan ovens reduce the temperature by 10-20°C. For any dish taking one hour or over to cook, reduce the cooking time by 10 minutes per hour.

* Shelf positions have been counted from the top of the oven to the base. A fan oven creates more even temperature throughout, therefore the shelf positions are not as critical.

7 - Cleaning and Maintenance

General advice

IMPORTANT

Before any operation of cleaning and maintenance disconnect the appliance from the electrical network.

– Do not use cleaning products with a chlorine or acidic base.

– **Important:**

the use of suitable protective clothing/gloves is recommended when handling or cleaning of this appliance.

WARNING

When correctly installed, your product meets all safety requirements laid down for this type of product category. However special care should be taken around the rear or the underneath of the appliance as these areas are not designed or intended to be touched and may contain sharp or rough edges, that may cause injury.

Spillage

Any spillage should be dealt with as soon as possible to prevent it becoming burnt on.

Vitroc ceramic cooking hob

– See page 19.

Attention

The appliance gets very hot, mainly around the cooking areas. It is very important that children are not left alone in the kitchen when you are cooking.

Do not use a steam cleaner because the moisture can get into the appliance thus make it unsafe.

Enamelled parts

All the enamelled parts must be cleaned with a sponge and soapy water or other non-abrasive products.

Dry preferably with a microfibre or soft cloth.

Acidic substances like lemon juice, tomato sauce, vinegar etc. can damage the enamel if left too long.

Stainless steel, aluminium parts and silk-screen printed surfaces

Clean using an appropriate product. Always dry thoroughly.

IMPORTANT: these parts must be cleaned very carefully to avoid scratching and abrasion. You are advised to use a soft cloth and neutral soap.

CAUTION: Do not use abrasive substances or non-neutral detergents as these will irreparably damage the surface.

Replacing the oven light bulb

Switch the cooker off at the mains.

When the oven is cool unscrew and replace the bulb with another one resistant to high temperatures (300°C), voltage 230 V (50 Hz), E14 and same power (check watt power as stamped in the bulb itself) of the replaced bulb.

Note: Oven bulb replacement is not covered by your guarantee.

Glass control panel

Clean using an appropriate product.

Always dry thoroughly.

Do not use harsh abrasive cleaners or sharp metal scrapers to clean the control panel since they can scratch the surface, which may result in shattering of the glass.

Inside of ovens

The oven should always be cleaned after use when it has cooled down.

The cavity should be cleaned using a mild detergent solution and warm water.

Suitable proprietary chemical cleaners may be used after first consulting with the manufacturers recommendations and testing a small sample of the oven cavity. Abrasive cleaning agents or scouring pads/cloths should not be used on the cavity surface.

- **NOTE:** The manufacturers of this appliance will accept no responsibility for damage caused by chemical or abrasive cleaning.

Attention: Do not store flammable material in the ovens.

Let the oven cool down and pay special attention no to touch the hot heating elements inside the oven cavity.

Assembly and dismantling of the side runner frames

- Fit the side runner frames into the holes on the side walls inside the oven (Fig. 7.1).
- Slide into the guides, the shelf and the tray (fig. 7.2).
- The rack must be fitted so that the safety notch, which stops it sliding out, faces the inside of the oven; the guard rail shall be at the back.
- To dismantle, operate in reverse order.

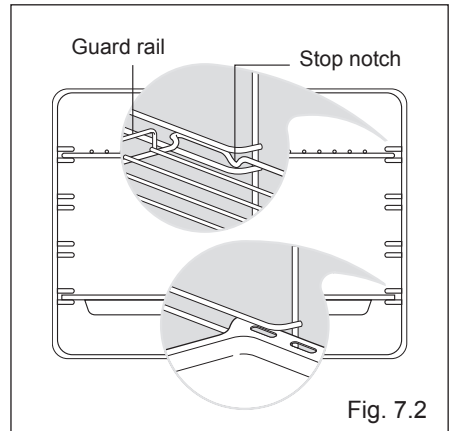
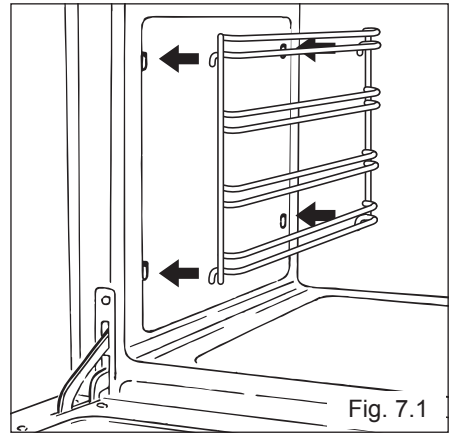

Storage compartment

The storage compartment is accessible through the pivoting panel (fig. 7.3).

Do not store flammable material in the ovens or in the storage compartment.

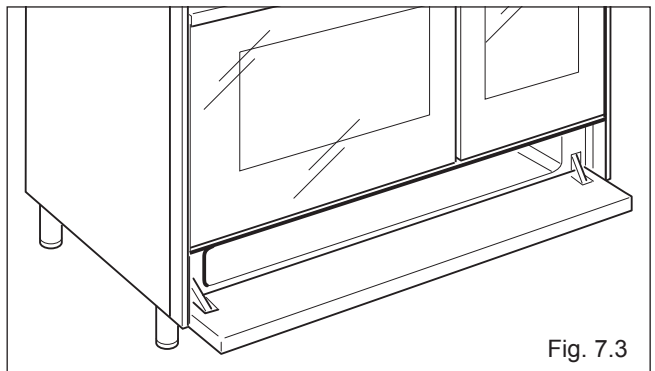

Removing the oven door

The oven door can easily be removed as follows:

- Open the door to the full extent (fig. 7.4a).
- Open the lever “A” completely on the left and right hinges (fig. 7.4b).
- Hold the door as shown in fig. 7.4d.
- Gently close the door (fig. 7.4c) until left and right hinge levers “A” are hooked to part “B” of the door (fig. 7.4b).
- Withdraw the hinge hooks from their location following arrow “C” (fig. 7.4e).
- Rest the door on a soft surface.

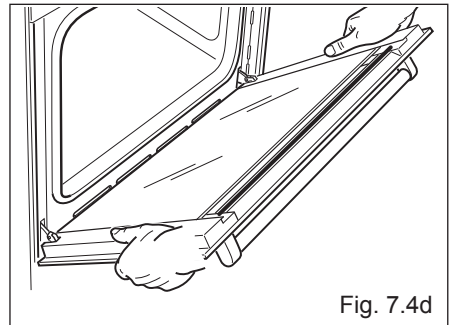
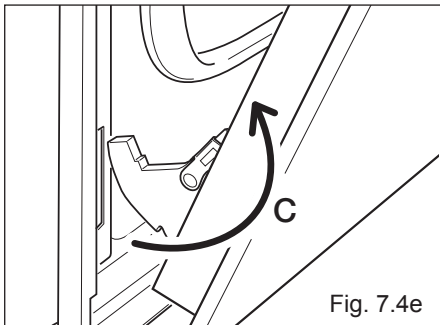
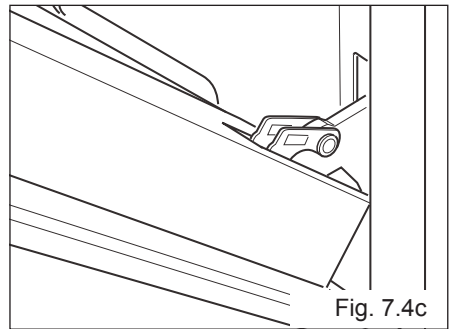
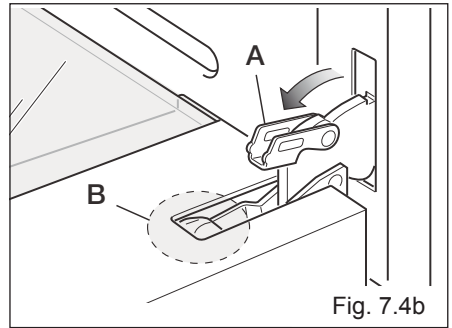
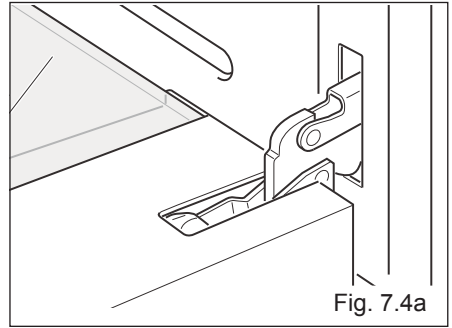

Oven doors - removing the inner pane of glass

The inner pane of glass can easily be removed for cleaning.

Removing the inner pane

- Open the door to the full extent (Fig. 7.4a).
- Open the lever “A” completely on the left and right hinges (Fig. 7.4b).
- Hold the door as shown in Fig. 7.4d.
- Gently close the door (fig. 7.4c) until left and right hinge levers “A” are hooked to part “B” of the door (fig. 7.4b).
- Gently pull out the inner pane of glass (fig. 7.5a).
- Clean the glass with an appropriate cleaner.
- Dry thoroughly, and place the pane on a soft surface.
- Now you can also clean the inside of the outer glass.

Do not use harsh abrasive cleaners or sharp metal scrapers to clean the panes of glass since they can scratch the surface, which may result in shattering of the glass.

Reassembling the inner pane

- Make sure the door is locked open (see fig. 7.4b).
- Check the correct positioning of the no.4 (four) silicon rubbers “D” (fig. 7.5b).
- Check that you are holding the pane the correct way. You should be able to read the wording on it as it faces you.
- Insert the inner pane in the left “E” and right “F” side guides (fig. 7.5c) and gently let it slide up to the retainers “H” (fig. 7.5d).
- Unlock the oven door by opening it completely and closing the lever “A” on the left and right hinges (fig. 7.4a).

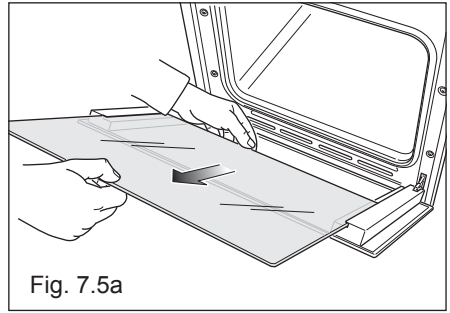

Fig. 7.5a

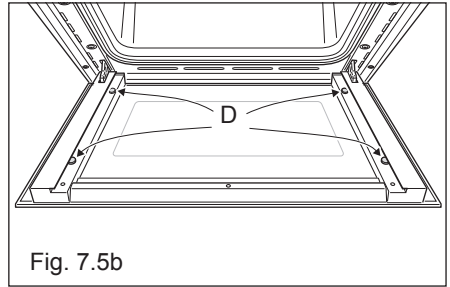

Fig. 7.5b

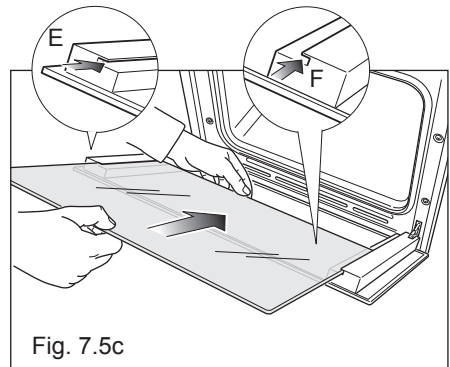

Fig. 7.5c

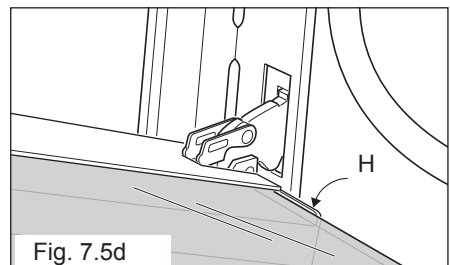
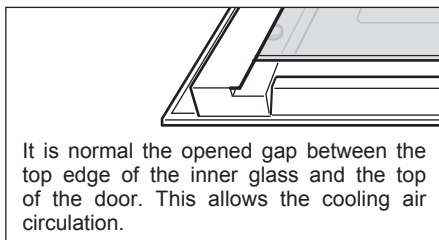

Fig. 7.5d

Helpful Advice

Trouble shooting

Problem

Food too brown but not cooked.

Remedy

Turn down the oven temperature slightly and cook a little longer

Problem

Food cooked but not brown enough.

Remedy

Increase temperature.

Problem

Food baking unevenly.

Remedy

1. The temperature may be slightly high turn it down
2. Position the food in the centre of the shelves rather than towards the sides of the oven.
3. Rotate the food a half turn in the oven.
4. Try pre-heating the oven for 5-15 minutes prior to baking.

Always remove cooked items as soon as they are ready and continue cooking the under-cooked items until they are completely finished.

Changing the Oven Cavity Light Bulb.

If the oven light falls:

1. Turn off the oven by switching the oven selector to "O", switch off at the cooker point.
2. When the oven is cool, reach back and upwards inside the oven, the bulb is in the top corner.
3. Unscrew the light glass cover, replace the bulb with a new one of the same specification and screw the cover back until it is hand tight.

NOTE: Oven bulb replacement is not covered by your guarantee.

Other bulbs cannot be changed by yourself and should be replaced by an authorised Caple Service Engineer.

Bulbs other than the oven bulb are covered by the guarantee.

IMPORTANT: Cooker get hot. Keep children away from this appliance at all times.

If Your Oven Does Not Work

Before calling a Caple service engineer run through the following checklist.

1. The cooker is connected to the power supply and that the fuse is intact.
2. Make sure the timer control (main oven only) is set to the manual position, and that the oven has not been set inadvertently for an automatic or timed programme.

If you are in any doubt about carrying out these checks, call Caple on 0844 8003830 or email us via service@caple.co.uk.

A charge will be made if the appliance is found to be in working order, or if it has not been installed in accordance with these instructions, or if it has been used incorrectly.

Caple “Built-in” Service

Should you require service at any time, please contact Caple Service by telephone on 0844 8003830 or email service@caple.co.uk.

Caple have a nationwide service network of engineers who will respond quickly to your call.

Always replace spare parts with genuine **Caple** spares. These are available from authorised **Caple Service Centres** or by mail order (please check contact details at www.caple.co.uk).

When ordering parts always quote the model number and serial number of your appliance.

YOUR GUARANTEE

Caple guarantees all parts of this product for one year from the date of purchase. During that time, should it become necessary Caple engineers will replace or repair all defective parts free of charge, except for parts subject to fair wear and tear, such as lightbulbs.

Parts and the engineers labour costs are chargeable after the first 12 months.

To qualify for benefits under the guarantee, you must be able to provide proof of date of purchase and the appliance must have been supplied, installed and used for domestic purposes only in accordance with Caple instructions.

Consequential losses and accidental damage to the product are not covered by the guarantee.

This guarantee does not affect your statutory or common law rights.

Caple cannot be responsible for the results of using this appliance for any other purposes other than those described in these instructions.

Caple
Fourth Way
Avonmouth
Bristol
BS11 8DW
www.caple.co.uk