



CR903SS

Caple 900mm 2 Cavity Range

INSTRUCTION MANUAL

Thank you for buying your new CAPLE cooker. To ensure that you get the best results from your new CAPLE cooker, we strongly suggest that you read this instruction manual thoroughly before use. This manual contains installation advice, cleaning tips and a cooking guide, as well as other important facts about your CAPLE cooker. If treated with care, your CAPLE appliance should give you years of trouble-free cooking.

**For Spare Parts, Technical Advice
or Product Service call the
CAPLE HELPLINE on 0870 241 1142**

(Answerphone outside office hours)

The **CE** marking confirms that the appliance conforms to the following EU directives:

- safety requirements of EEC Directive "Gas" 90/396;
- safety requirements of EEC Directive "Low voltage" 73/23;
- protection requirements of EEC Directive "EMC" 89/336;
- requirements of EEC Directive 93/68.

Safety Reminders

Instruction Book

This appliance should only be used for its intended purpose as described in these instructions.

Ensure that you fully understand these instructions before operating this appliance.

Space Requirements

Ensure that the specified ventilation space around the appliance is not obstructed.

Food Splashes

Always wipe clean the oven after use. Food splashes can carry on cooking next time and may become a fire hazard.

Hot Surfaces

It is important to remember that the surfaces of cooking appliances get hot during use and retain the heat for some time after switching off.

It is therefore advisable to keep small children away from the appliance.

The Grill and Top oven element

are exposed, so take great care when placing food in the oven or removing it. Use the grill pan handles or gloves.

DO NOT line the oven, grids, trays etc. with aluminium foil as this could adversely affect the heating elements and it could also damage the interior surfaces.

DO NOT place flammable materials in the oven or in the storage compartment.

Faults

Do not continue to use this appliance if it appears to be faulty.

After Use

After use, ensure that the hob knobs are in position ● (off), and close the main gas delivery valve or the gas cylinder valve.

Switch the oven controls off.

Always switch off at the isolating switch before cleaning the appliance, or attempting any maintenance task, or when not in use for long periods (when on holiday).

CAPLE Service

To ensure the continued safe and efficient operation of this appliance, we recommend that any servicing or repairs are carried out only by an authorised CAPLE SERVICE ENGINEER.

Electrical Requirements

WARNING!
ELECTRICITY CAN BE EXTREMELY DANGEROUS.
THIS APPLIANCE MUST BE EARTHED.

For your safety please read the following information:

This appliance must be installed by a qualified technician according with the current local regulations and in compliance with the manufacturer instructions.

The appliance must be connected to the electrical network verifying above all that the voltage corresponds to the value indicated on the specifications plate and that the cables section of the electrical plant can bear the load which is also indicated on the plate.

The cooker must be connected directly to the mains placing an omnipolar switch with minimum opening between the contacts of 3 mm between the appliance and the mains.

The power supply cable must not touch the hot parts and must be positioned so that it does not exceed 75°C at any point.

Once the cooker has been installed, the switch or socket must always be accessible.

Before effecting any intervention on the electrical parts the appliance must be disconnected from the network.

1 - Electrical Installation - Wall box connection

This appliance must be connected to a double pole isolating switch (fig. 1.1) and to the terminal block in the cooker (figs. 1.2 & 1.3) using the following guide:

- 1) The wire which is coloured brown must be connected to the terminal marked **L** (Live), or coloured Red.
- 2) The wire which is coloured blue must be connected to the terminal marked **N** (Neutral), or coloured Black.
- 3) The wire which is coloured green and yellow must be connected to the terminal marked **E** (Earth) \equiv or coloured Green.

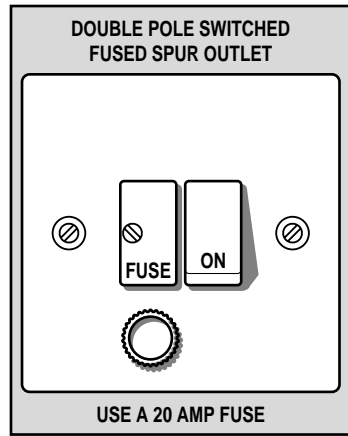

Fig. 1.1

IMPORTANT: These connections must be carried out by a qualified electrical engineer.

CONNECTING FEEDER CABLE

To connect the feeder cable to the cooker it is necessary to:

- Remove the screw that hold shield “A” behind the cooker (fig. 1.2).
- Insert the feeder cable of the suitable section (as described in the next chapter) into the cable clamp “D”.
- Connect the phase and earth cables to the terminal block “B” according to the diagram in figure 1.3.
- Pull the feeder cable and block it with cable clamp “D”.
- Re-mount shield “A”.

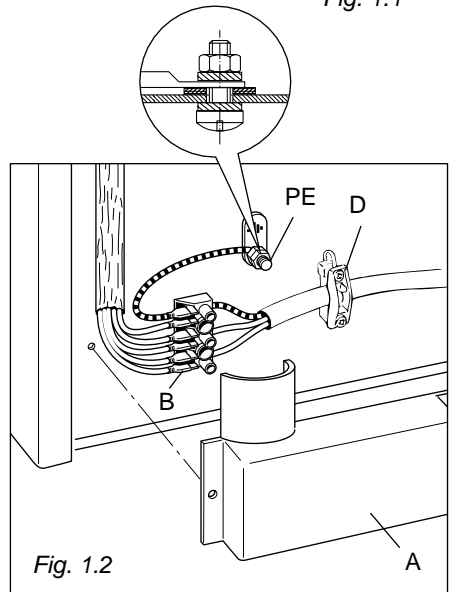

Fig. 1.2

FEEDER CABLE SECTION type H05RR-F

230 V ~ 3 x 2,5 mm² (**)

(**) – Connection with wall box connection.

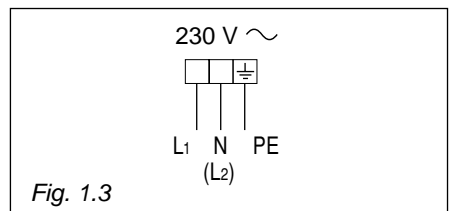

Fig. 1.3

FOR THE INSTALLER

2 - Location

The cooker must be installed by a qualified technician and in compliance with local safety standards.

This cookers has class “2/1” overheating protection so that it can be installed next to a cabinet.

If the cooker is installed adjacent to furniture which is higher than the gas hob cooktop, a gap of at least 50 mm must be left between the side of the cooker and the furniture. The furniture walls adjacent to the cooker must be made of material resistant to heat.

The veneered syntetical material and the glue used must be resistant to a temperature of 90°C in order to avoid ungluing or deformations.

The cooker may be located in a kitchen, a kitchen/diner or bed-sitting room but not in a room containing a bath or shower.

Curtains must not be fitted immediatly behind appliance or within 500 mm of the sides.

It is essential that the cooker is positioned as stated below.

If the cooker is located on a pedestal it is necessary to provide safety measures to prevent falling out.

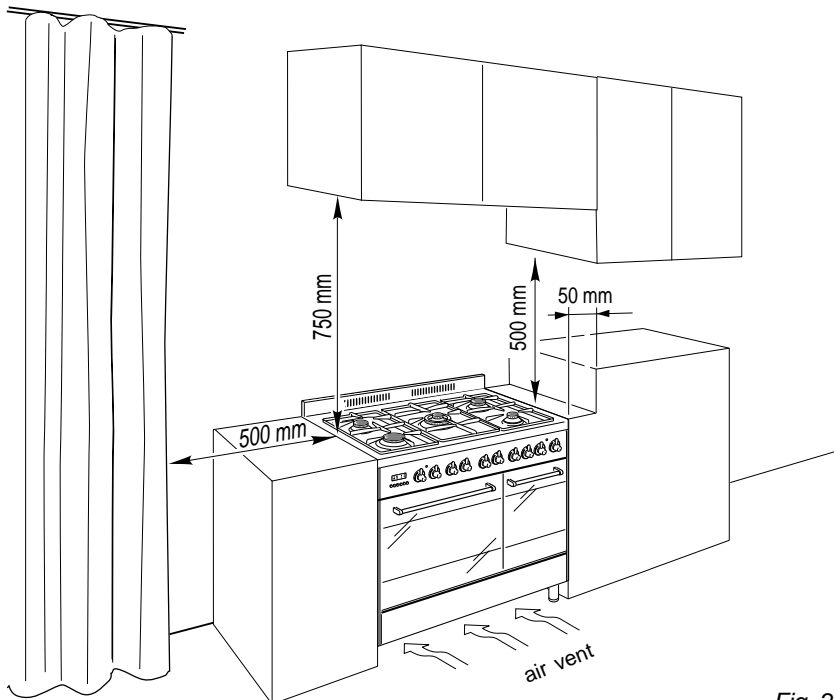

Fig. 2.1

Backguard

Before installing the cooker, assemble the backguard "C" (fig. 2.2).

1. The backguard "C" can be found packed at the rear of the cooker.
2. Before assembling remove any protective film/adhesive tape.
3. Remove the two spacers "A" and the screw "B" from the rear of the cooktop.
4. Assemble the backguard as shown in figure 2.2 and fix it by screwing the central screw "B" and the spacers "A".

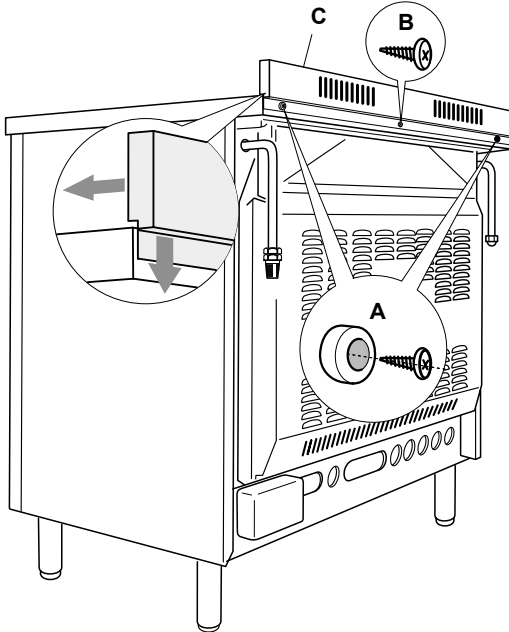

Fig. 2.2

Fitting the adjustable feet

The adjustable feet must be fitted to the base of the cooker before use.

Rest the rear of the cooker on a piece of the polystyrene packaging exposing the base for the fitting of the feet.

Fit the 4 legs by screwing them tight into the support base as shown in picture 2.4.

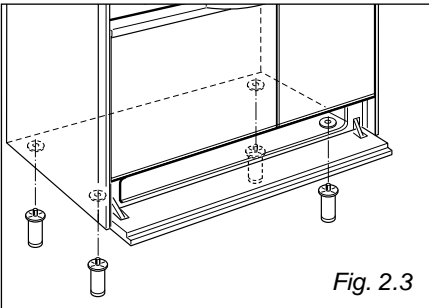

Fig. 2.3

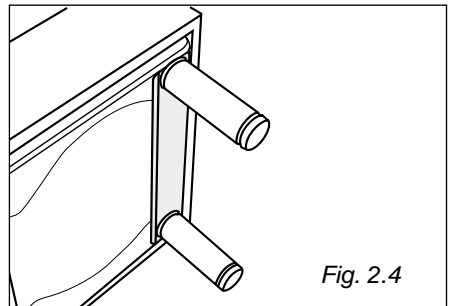

Fig. 2.4

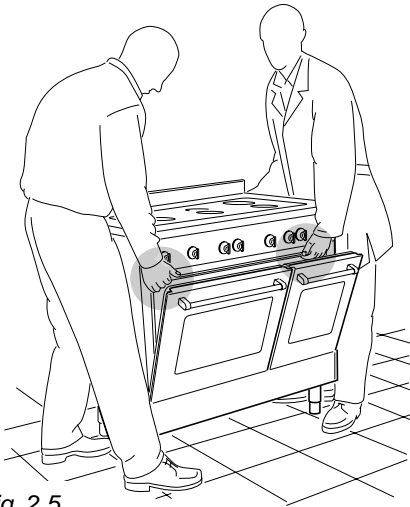

Fig. 2.5

WARNING

When raising cooker to upright position always ensure two people carry out this manoeuvre to prevent damage to the adjustable feet (fig. 2.5).

WARNING

Be careful! do not lift the cooker by the door handle when raising to the upright position (fig. 2.6).

WARNING

When moving cooker to its final position **DO NOT DRAG** (fig. 2.7). Lift feet clear of floor (fig. 2.5).

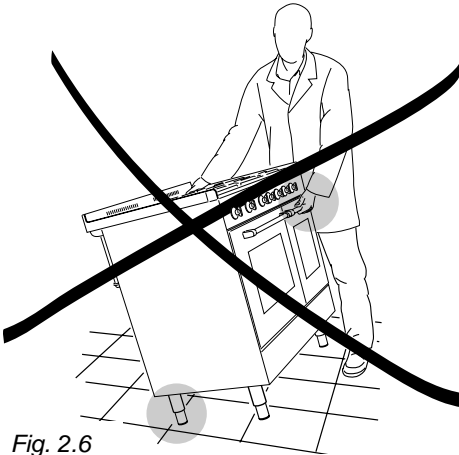

Fig. 2.6

Levelling the cooker

The cooker may be levelled by screwing the lower ends of the feet IN or OUT (fig. 2.8).

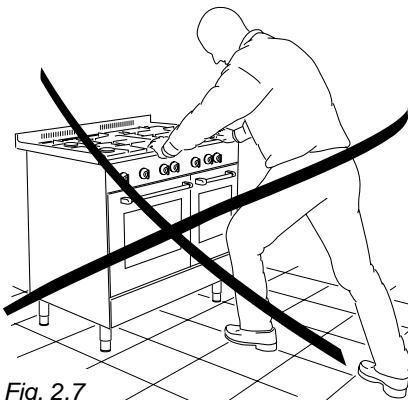

Fig. 2.7

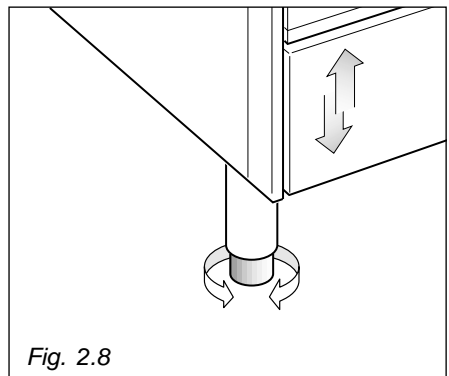

Fig. 2.8

Provision for ventilation

The room containing the cooker should have an air supply in accordance with BS.5540: Part 2: 1989.

All rooms require an openable window or equivalent while some rooms require a permanent vent in addition to the openable window.

The cooker should not be installed in a bed-sitting room, of volume less than 21 m³. Where a DOMESTIC COOKER is installed in a room or internal space, that room or internal space shall be provided with a permanent opening which communicates directly with outside air and is sized in accordance with table below. In domestic premises the permanent opening shall be an air vent.

If there are other fuel burning appliances in the same room, BS.5540: Part 2: 1989 should be consulted to determine the requisite air vent requirements.

If the cooker is installed in a cellar or basement, it is advisable to provide an air vent of effective area 100 cm², irrespective of the room volume.

MINIMUM PERMANENT OPENING FREE AREA FOR FLUELESS APPLIANCE						
Type of appliance	Maximum appliance rated input limit	Room volume				Openable window or equivalent also required
		< 5 m ³	5 m ³ to 10 m ³	11 m ³ to 20 m ³	> 20 m ³	
Domestic oven, hot-plate, grill or any combination thereof.	None	100 cm ²	50 (*) cm ²	Nil cm ²	Nil cm ²	Yes

(*) If the room or internal space containing these appliances has a door which opens directly to outside, no permanent opening is required.

3 - Gas connection

GAS INSTALLATION

IMPORTANT NOTE

This appliance is supplied for use on NATURAL GAS only and cannot be used on any other gas without modification.

This appliance is manufactured for conversion to LPG if required and is supplied with a conversion kit.

The cooker must be installed by a qualified person in accordance with the Gas Safety (Installation and Use) (Amendment) Regulation 1990 and the relevant building/I.E.E. Regulations.

The following British Standards should be used as reference when installing this appliance.

BS6172 1990, BS5440 part 2 1989 and BS6891 1988.

Failure to install the appliance correctly could invalidate any manufacturers warranty and lead to prosecution under the above quoted regulation.

In the UK C.O.R.G.I registered installers are authorised to undertake the installation and service work in compliance with the above regulations.

GAS CONNECTION

The installation of the cooker to Natural Gas or LP Gas must be carried out by a qualified gas engineer. Installers shall take due account of the provisions of the relevant British Standards Code of Practice, the Gas Safety Regulations and the Building Standards (Scotland) (Consolidation) Regulations issued by the Scottish Development Department.

INSTALLATION TO NATURAL GAS

Installation to Natural Gas must conform to the Code of Practice, etc. The supply pressure for Natural Gas is 20 mbar.

INSTALLATION TO LP GAS

This appliance must only be connected to LPG after an LPG conversion kit has been fitted, (see pages from 12 to 14). When operating on Butane gas a supply pressure of 28-30 mbar is required. When using Propane gas a supply pressure of 37 mbar is required. The installation must conform to the relevant British Standards.

Warning: Only a qualified gas engineer, also with technical knowledge of electricity should install the cooker. He should observe the Regulations and Codes of Practice governing such installation of gas cookers.

Note: It is recommended that the gas connection to the cooker is installed with a flexible connecting tube made to BS 5386.

GAS CONNECTION

The gas supply must be connected to the gas inlet which is located at the left or the right hand rear of the appliance (fig. 3.1).

The pipe does not cross the cooker.

When screwing the connecting tube operate with two spanners (fig. 3.2).

The unused end inlet pipe must be closed with the plug, interposing the gasket.

After connecting to the mains, check that the coupling are correctly sealed, using soapy solution, but never a flame.

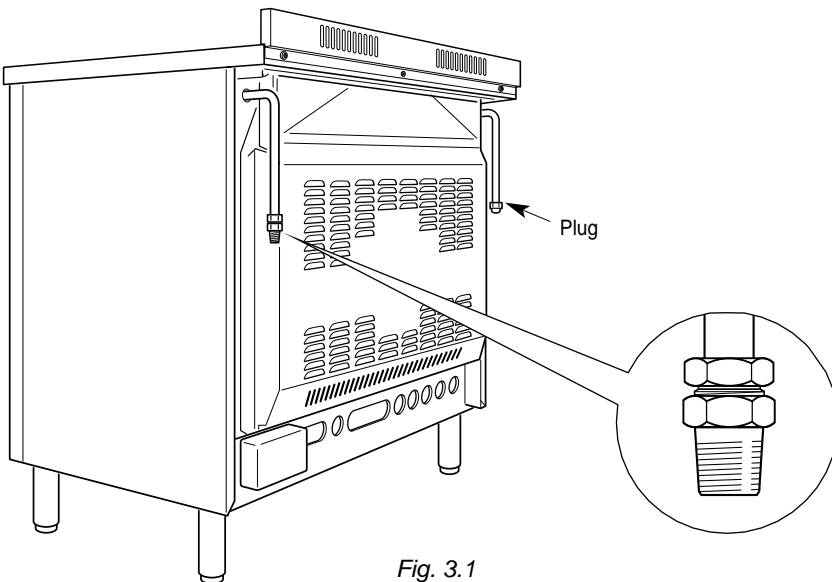
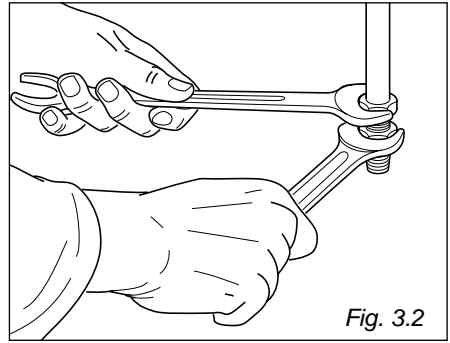

Conversion to LPG

Conversion procedure INJECTORS REPLACEMENT

Select the injectors to be replaced according to the "Table for the choice of the injectors" (page 14).

To replace the injectors proceed as follows:

- Remove pan supports and burners from the cooktop.
- Using a wrench, substitute the nozzle injectors "J" (fig. 3.3, 3.4) with those most suitable for the kind of gas for which it is to be used.

The burners are conceived in such a way so as not to require the regulation of the primary air.

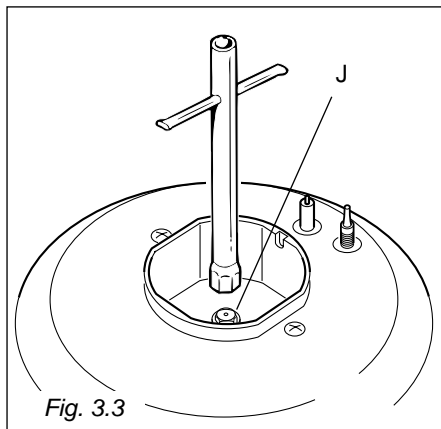

MINIMUM BURNER SETTING ADJUSTMENT

In the minimum position the flame must have a length of about 4 mm and must remain lit even when turned quickly from the maximum position to minimum.

The flame adjustment is done in the following way:

- Turn on the burner
- Turn the tap to the MINIMUM position
- Take off the knob
- With a small flat screwdriver turn the screw inside the tap rod to the correct regulation (fig. 3.5).

Normally for G30/G31, the regulation screw is tightened up.

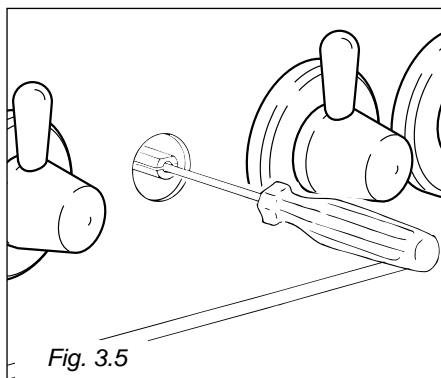
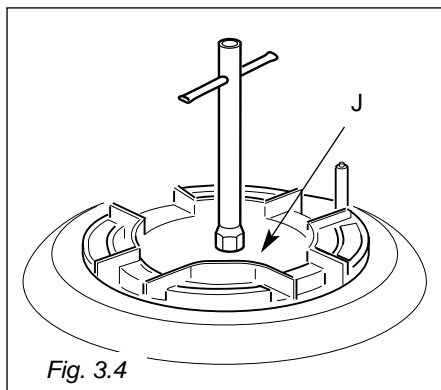

BURNERS	Nominal Power [kW]	Reduced Power [kW]	G 30 - 28-30 mbar G 31 - 37 mbar		G 20 20 mbar	
			By-pass [1/100 mm]	Ø injector [1/100 mm]	By-pass [1/100 mm]	Ø injector [1/100 mm]
Auxiliary (A)	1,00	0,30	27	50	adjustable	72 (X)
Semi-rapid (SR)	1,75	0,45	32	65		97 (Z)
Rapid (R)	3,00	0,75	42	85		115 (Y)
Triple-ring	3,50	1,50	65	95		135 (T)

INCREASE OF AIR NECESSARY FOR GAS COMBUSTION (2 m³/h x kW)

BURNERS	Air necessary for combustion [m ³ /h]
Auxiliary (A)	2,00
Semi-rapid (SR)	3,50
Rapid (R)	6,00
Triple-ring	7,00

Lubrication of the gas taps

If the gas tap becomes stiff, it is necessary to dismount it accurately clean it with gasoline and spread a bit of special grease resistant to high temperatures on it.

The operations must be executed by a qualified technician.

4 - Features and Technical Data

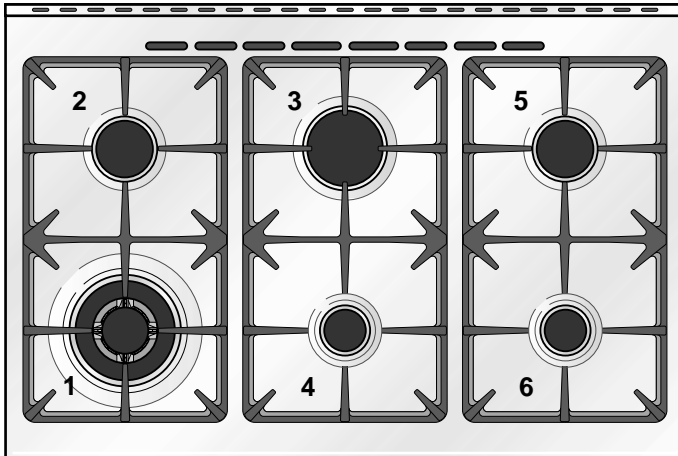

Fig. 4.1

Cooking hob - (Fig. 4.1)

1. Triple-ring burner (PB)	3,50 kW
2. Semi-rapid burner (SR)	1,75 kW
3. Rapid burner (R)	3,00 kW
4. Auxiliary burner (A)	1,00 kW
5. Semi-rapid burner (SR)	1,75 kW
6. Auxiliary burner (A)	1,00 kW

Control Panel

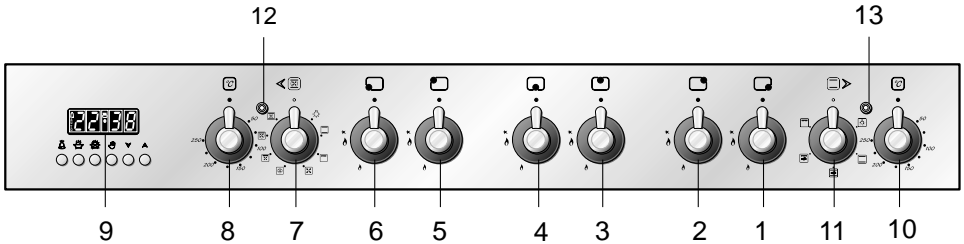

Fig. 4.2

Control panel - (Fig. 4.2)

1. Front right burner control knob
2. Rear right burner control knob
3. Rear central burner control knob
4. Front central burner control knob
5. Rear left burner control knob
6. Front left burner control knob
7. Multifunction main oven switch knob
8. Multifunction main oven thermostat knob
9. Electronic programmer (main oven only)
10. Conventional oven thermostat knob
11. Conventional oven switch knob

Pilot lamps:

12. Main oven thermostat indicator light
13. Conventional oven thermostat indicator light

Please note: This appliance incorporates a safety cooling fan which you will hear operating whenever the oven or grill are in use. This fan is to reduce the external temperature of the appliance and cool the internal components.

How To Use the Hob Burners

Hob burners



Each hob burner is controlled by a separate gas tap operated by a control knob (fig. 4.3) which has 3 positions marked on the knob, these are:

– Symbol ● : tap closed (burner off)

– Symbol  : High (maximum)

– Symbol  : Low (minimum)

Push in and turn the knob anti-clockwise to the selected position.

 Low  High

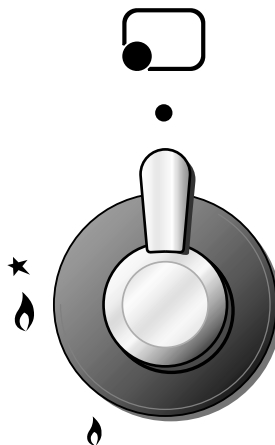

Fig. 4.3

To turn the burner off, fully rotate the knob clockwise to the off position: ●.

The maximum setting of the control tap is for boiling, the minimum setting is for slow cooking and simmering.

All working positions must be chosen between the maximum and minimum setting, never between the maximum setting and the “OFF” position.

Lighting of the hob burners

To ignite the burner, the following instructions are to be pursued:

- 1) Lightly press and turn the knob anti-clockwise, and make the symbol  printed on the control panel to match with the indicator on the knob (fig. 4.3).
- 2) Press the knob to operate the electric ignition; or, in case of power cut, approach a flame to the burner.
- 3) Adjust the burner according to the power required.

Electric ignition

The sparks generated by the electrodes close to the burners will ignite the chosen burner. Whenever the lighting of the burners will result difficult due to peculiar conditions of the gas features or supply, it is advised to repeat the ignition with the knob on “minimum” position.

Choice of burner

The burner must be chosen according to the diameter of the pans and energy required.

Burners	Pan diameter
Auxiliary	12 ÷ 14 cm
Semi-rapid	16 ÷ 24 cm
Rapid	24 ÷ 24 cm
Triple-ring	26 ÷ 28 cm

do not use pans with concave or convex bases

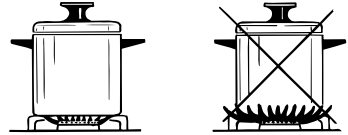

Fig. 4.4

Saucepans with handles which are excessively heavy, in relationship to the weight of the pan, are safer as they are less likely to tip.

Pans which are positioned centrally on burners are more stable than those which are offset.

It is far safer to position the pan handles in such a way that they cannot be accidentally knocked.

When deep fat frying fill the pan only one third full of oil.

DO NOT cover the pan with a lid and **DO NOT** leave the pan unattended.

In the unfortunate event of a fire, leave the pan where it is and turn off all controls.

Place a damp cloth or correct fitting lid over the pan to smother the flames.

DO NOT use water on the fire.

Leave the pan to cool for at least 30 minutes.

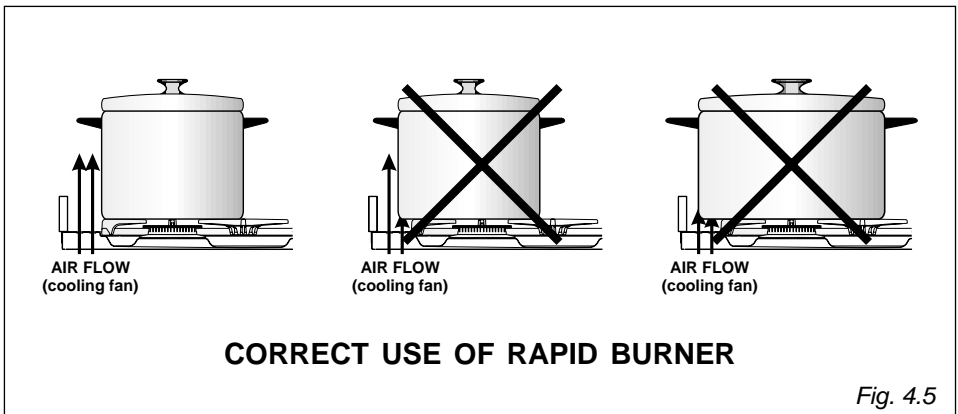
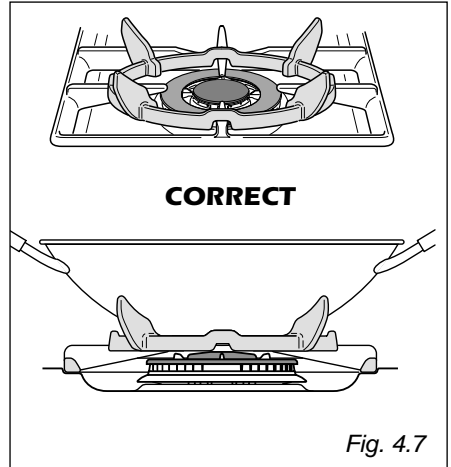
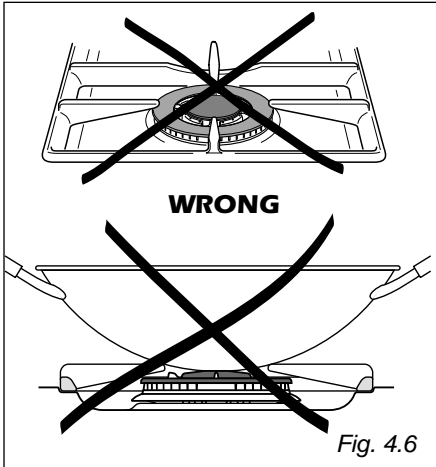

Fig. 4.5

Correct use of triple-ring burner

The flat-bottomed pans are to be placed directly onto the pan-support.

When using a WOK you need to place the supplied stand in the burner to avoid any faulty operation of the triple-ring burner (Fig. 4.6 - 4.7).









5 - Electronic programmer (main oven only)

The electronic programmer is a device which groups together the following functions:

- 24 hours clock with illuminated display
- Timer (up to 23 hours and 59 minutes)
- Program for automatic oven cooking
- Program for semi-automatic oven cooking.



Description of the buttons:

-  Timer
-  Cooking time
-  End of cooking time
-  Manual position and cancellation of the inserted cooking program
-  Advance of the numbers of all programs
-  Turning back of the numbers of all programs and changing the frequency of the audible signal.



Description of the lighted symbols:

AUTO - *flashing* - Programmer in automatic position but not programmed

AUTO - *always lighted* - Programmer in automatic position with program inserted.

-  Automatic cooking taking place
-  Timer in operation
-  and **AUTO** - flashing - Program error.
(The time of day lies between the calculated cooking start and end time).

Note:

Select a function by the respective button and, in 5 seconds, set the required time with the  /  buttons (“one-hand” operation).

A power cut makes the clock go to zero and cancels the set programs.

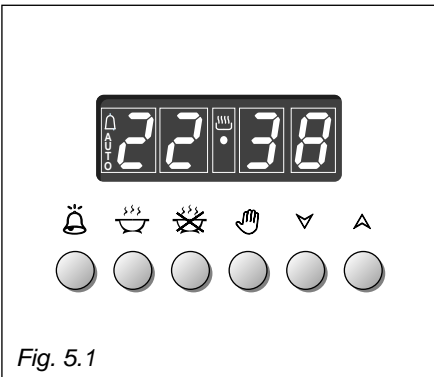

Fig. 5.1

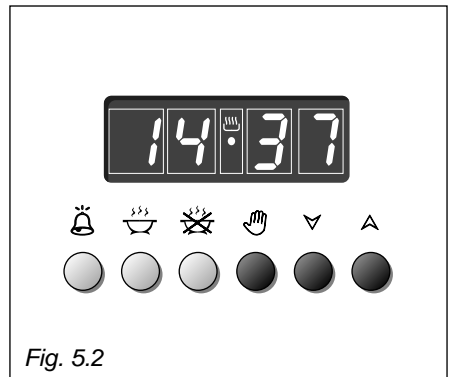









Fig. 5.2

ELECTRONIC CLOCK (fig. 5.2)

The programmer is equipped with an electronic clock with lighted numbers which indicates hours and minutes.



Upon immediate connection of the oven or after a power cut, three zeros will flash on the programmer panel.

To set the hour it is necessary to push the  button and then the  or  button until you have set the exact hour (fig. 5.2).

Another way is to simultaneously push the   two buttons and at the same time push the  or  button.

Nota: Changing the hour button deletes any cooking program.

NORMAL COOKING WITHOUT THE USE OF THE PROGRAMMER

To manually use the oven, that is, without the aid of the programmer, it is necessary to cancel the flashing AUTO by pushing the button  (AUTO will be switched off and the symbol  will go on - Fig. 5.3).



Attention: If the AUTO symbol is steady a cooking program has already been programmed, by pushing the button  you have cancelled of the program and the switched to manual.

If the oven is switch on, you must switch off manually.

ELECTRONIC TIMER

The timer program consists only of a buzzer which may be set for a maximum period of 23 hours and 59 minutes.

If the **AUTO** flashing push the  button.

To set the time, push the  button and the  or  until you obtain the desired time in the panel (fig. 5.4).

Having finished the setting, the clock hour will appear on the panel and the  symbol will be lighted.

The countdown will start immediately and may be seen at any moment on the panel by simply pressing the button .

At the end of the time, the  symbol will be switched off and an intermittent buzzer will go off; this can be stopped by pressing one of any of the buttons.

SETTING THE FREQUENCY OF THE AUDIBLE SIGNAL

The selection from 3 possibilities of sound can be made by pressing the  button.

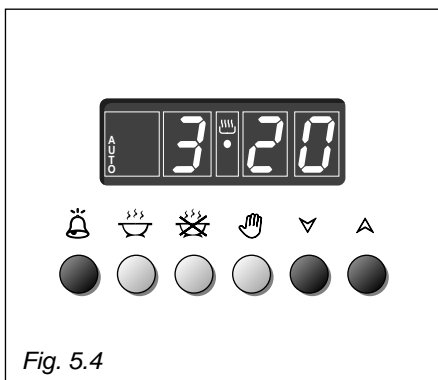
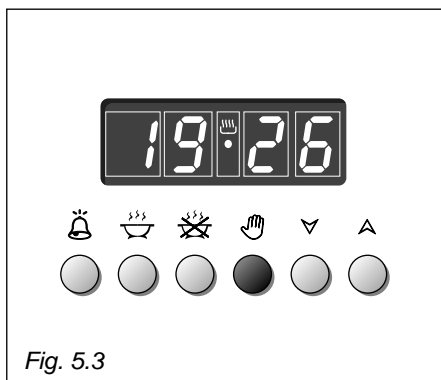









AUTOMATIC OVEN COOKING

To cook food automatically in the oven, it is necessary to:

1. Set the length of the cooking time
2. Set the end of the cooking time
3. Set the temperature and the oven cooking program.

These operations are done in the following way:

1. Set the length of the cooking time by pushing the  button and the  button to advance, or  to go back if you have passed the desired time (fig. 5.5). The **AUTO** and the  symbol will be on.
2. Set the end of the cooking time by pressing the  button (the cooking time already added to the clock time will appear), and the  button (fig. 5.6); if you pass the desired time you may get back by pushing the  button.

After this setting, the  symbol will go off. If after this setting, the **AUTO** flash on the panel and a buzzer gives off, it means there was an error in the programming.

In this case, modify the end of cooking time or the cooking time itself by following again the above mentioned instructions.

3. Set the temperature and the cooking program by using the switch and thermostat knobs of the oven (see specific chapters).

Now the oven is programmed and everything will work automatically, that is the oven will turn on at the right moment to end the cooking at the established hour. During cooking, the  symbol remains on.

By pushing the  button you can see the time that remains until the end of cooking.

The cooking program may be cancelled in any moment by pushing the .

At the end of the cooking time the oven will turn off automatically, the  symbol will turn off, **AUTO** will flash and a buzzer will sound, which can be turned off by pushing any of the buttons.

Turn the switch and thermostat knobs to zero and put the programmer onto "manual" by pushing the .

Attention: A power cut makes the clock go to zero and cancels the set programs.

After a power cut, three zeros will flash on the panel.

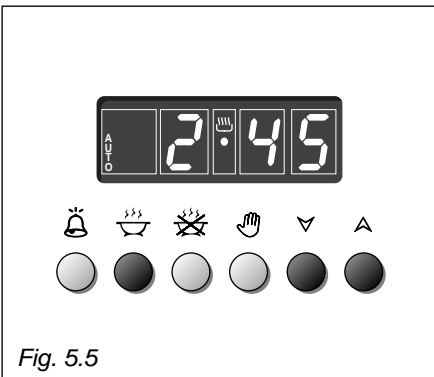

Fig. 5.5

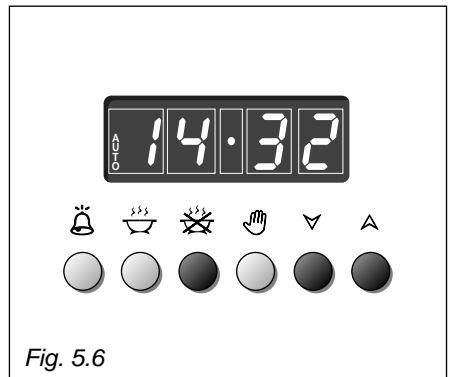







Fig. 5.6

SEMI - AUTOMATIC COOKING

This function is only used to set the **END** of the cooking time of the oven. There are two ways of setting this function.



1. Set the length of the cooking time by pushing the  button and the  button to advance, or  to go backwards (Fig. 5.7). This sets the desired "stop" time.

or

2. Set the end of the cooking time by pushing the  button and the  button to advance, or  to go backwards if you have passed the desired time (Fig. 5.8).

AUTO and the  symbol will be on. Then set the temperature and the cooking program using the oven switch and thermostat knob (see relevant sections for details).

The oven is switched on and it will be switched off automatically at the end of the desired time.

During cooking, the  symbol remains on and by pressing the button  you can see the time that remains till the end of the cooking.

The cooking time can be cancelled at any moment by pushing the  button.

At the end of the cooking, the  symbol will turn off, the **AUTO** will flash and a buzzer will sound.

The buzzer can be cancelled by pressing any of the buttons.

Turn the switch and thermostat knobs to zero and reset the programmer back to "manual" by pressing the  button.

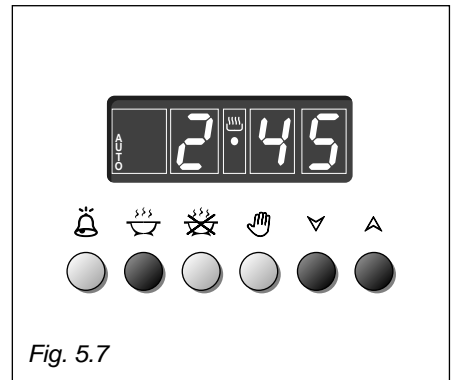

Fig. 5.7

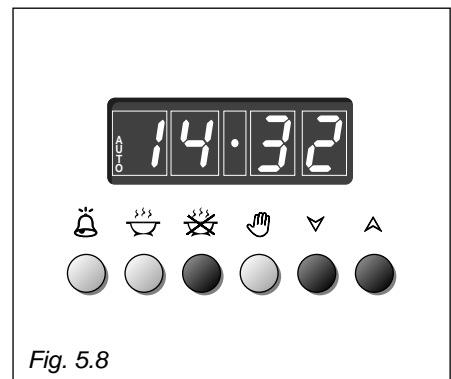

Fig. 5.8

6 - How To Use the Multi-function main oven

Attention: the oven door becomes very hot during operation. Keep children away.



General features

As its name indicates, this is an oven that presents particular features from an operational point of view.

In fact, it is possible to insert 7 different programs to satisfy every cooking need. The 7 positions, thermostatically controlled, are obtained by 4 heating elements which are:

– Bottom element	1400 W
– Top element	1000 W
– Grill element	2000 W
– Circular element	2500 W
– Fan motor	25 W
– Oven lamp	15 W

NOTE:

Upon first use, it is advisable to operate the oven for 30 minutes in the position  and for another 30 minutes at the maximum temperature (thermostat knob on position 250) in the positions  and , to eliminate possible traces of grease on the heating elements.

Clean the oven and accessories with warm water and washing-up liquid.

WARNING:

The door is hot use the handle.

OPERATING PRINCIPLES

Heating and cooking in the MULTI-FUNCTION oven are obtained in the following ways:

a. by normal convection

The heat is produced by the upper and lower heating elements.

b. by forced convection

A fan sucks in the air contained in the oven muffle, which sends it through the circular heating element and then sends it back through the muffle. Before the hot air is sucked back again by the fan to repeat the described cycle, it envelops the food in the oven, provoking a complete and rapid cooking.

It is possible to cook several dishes simultaneously.

c. by semi-forced convection

The heat produced by the upper and lower heating elements is distributed throughout the oven by the fan.

d. by radiation

The heat is irradiated by the infra red grill element.

e. by radiation and ventilation

The irradiated heat from the infra red grill element is distributed throughout the oven by the fan.

f. by ventilation

The food is defrosted by using the fan only function without heat.

Thermostat knob (fig. 6.1)

To turn on the heating elements of the oven, set the switch knob on the desired program and the thermostat knob onto the desired temperature.

To set the temperature, it is necessary to make the knob lever meet the chosen number.

The elements will turn on or off automatically according to the energy need which is determined by the thermostat.

The operation of the heating elements is signalled by a light on the control panel.

Function selector knob (fig. 6.2)

Rotate the knob clockwise to set the oven for one of the following functions:



Oven light

By turning the knob onto this setting we light the oven cavity (15 W). The oven remains alight while any of the functions is on.



Traditional convection cooking

The upper and lower heating elements are switched on. The heat is diffused by natural convection and the temperature must be regulated between 50° C and 250° C with the thermostat knob.

It is necessary to preheat the oven before introducing the foods to be cooked.

Recommended for:

For foods which require the same cooking temperature both internally and externally, i. e. roasts, spare ribs, meringue, etc.

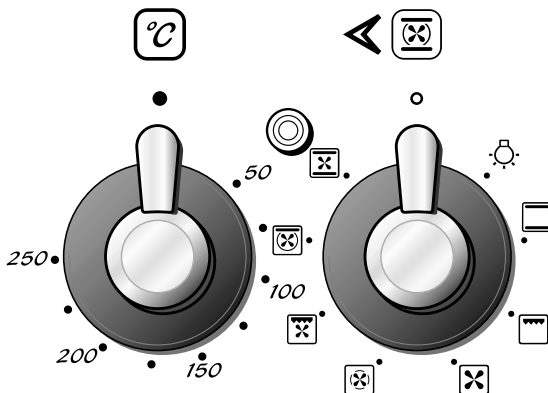

Fig. 6.1

Fig. 6.2



Grilling

The infra-red heating element is switched on. The heat is diffused by radiation.

Use with the **oven door closed** and the thermostat knob to between **50°** and **250°C** for **max 15** minutes, then to position **175°C**.

Note: It is recommended that you do not grill for longer than 30 minutes at any one time.

Attention: the oven door becomes very hot during operation. Keep children away.

For correct use see chapter "USE OF THE GRILL".

Recommended for:

Intense grilling action for cooking with a broiler; browning, crisping, "au gratin", toasting, etc.



Hot air cooking

The circular element and the fan are on. The heat is diffused by forced convection and the temperature must be regulated between 50° and 250 °C with the thermostat knob.

It is not necessary to preheat the oven.

Recommended for:

For foods that must be well done on the outside and tender or rare on the inside, i. e. lasagna, lamb, roast beef, whole fish, etc.



Defrosting frozen foods

Only the oven fan is on.

To be used with the thermostat knob on "●" because the other positions have no effect. The defrosting is done by simple ventilation without heat.

Recommended for:

To rapidly defrost frozen foods; 1 kilogram requires about one hour.

The defrosting times vary according to the quantity and type of foods to be defrosted.



Ventilated grill cooking

The infra-red ray grill and the fan are on. The heat is mainly diffused by radiation and the fan then distributes it throughout the oven. The temperature must be regulated between 50° and 175 °C **for max 30 minutes**, with the thermostat knob.

It is necessary to preheat the oven for about 5 minutes.

Use with the oven door closed.

Attention: the oven door becomes very hot during operation.

Keep children away.

For correct use see chapter "GRILLING AND "AU GRATIN".

Recommended for:

For grill cooking when a fast outside browning is necessary to keep the juices in, i. e. veal steak, steak, hamburger, etc.



Maintaining temperature after cooking or slowly heating foods

The upper element and the circular element connected in series, are switched on; also the fan is on.

The heat is diffused by forced convection with the most heat being produced by the upper element.

The temperature must be regulated between 50° and 140 °C with the thermostat knob.

Recommended for:

To keep foods hot after cooking. To slowly heat already cooked foods.



Convection cooking with ventilation

The upper and lower heating elements and the fan turn on.

The heat coming from the top and bottom is diffused by forced convection.

The temperature must be regulated between 50° and 250 °C with the thermostat knob.

Recommended for:

For foods of large volume and quantity which require the same internal and external degree of cooking; for ie: rolled roasts, turkey, legs, cakes, etc.

Cooking Advice

STERILIZATION

Sterilization of foods to be conserved, in full and hermetically sealed jars, is done in the following way:

- Set the switch to position .
- Set the thermostat knob to position 185 °C and preheat the oven.
- Fill the dripping pan with hot water.
- Set the jars onto the dripping pan making sure they do not touch each other and the door and set the thermostat knob to position 135 °C.

When sterilization has begun, that is, when the contents of the jars start to bubble, turn off the oven and let cool.

Regeneration

Set the switch to position  and the thermostat knob to position 150° C.

Bread becomes fragrant again if wet with a few drops of water and put into the oven for about 10 minutes at the highest temperature.

Roasting

To obtain classical roasting, it is necessary to remember:

- that it is advisable to maintain a temperature between 180 and 200 °C.
- that the cooking time depends on the quantity and the type of foods.

Grilling and “au gratin”

Set the switch to position .

Set the thermostat to position 175 °C and after having preheated the oven, simply place the food on the shelf.



Close the door and let the oven operate with the thermostat on, until grilling is complete.

Adding a few dabs of butter before the end of the cooking time gives the golden “au gratin” effect.

Note: It is recommended that you do not grill for longer than 30 minutes at any one time.

ATTENTION: the oven door becomes very hot during operation. Keep children away.

Simultaneous cooking of different foods

The MULTI-FUNCTION oven set on position  and  gives simultaneous heterogeneous cooking of different foods. Different foods such as fish, cake and meat can be cooked together without mixing the smells and flavours.

This is possible since the fats and vapors are oxidized while passing through the electrical element and therefore are not deposited onto the foods.

The only precautions to follow are:

- The cooking temperatures of the different foods must be as close to as possible, with a maximum difference of 20° - 25 °C.
- The introduction of the different dishes in the oven must be done at different times in relation to the cooking times of each one.

The time and energy saved with this type of cooking is obvious.

Use of the grill

Preheat the oven for about 5 minutes.

Introduce the food to be cooked, positioning the rack as close to the grill as possible.

The drip pan should be placed under the rack to catch the cooking juices and fats.

Grilling with the oven door closed.

Do not grill for longer than 30 minutes at any one time.

Caution: the oven door becomes very hot during operation.

Keep children well out of reach.

Oven cooking

Before introducing the food, preheat the oven to the desired temperature.

For a correct preheating operation, it is advisable to remove the tray from the oven and introduce it together with the food, when the oven has reached the desired temperature.

Check the cooking time and turn off the oven 5 minutes before the theoretical time to recuperate the stored heat.



7 - How To Use the Conventional oven

General features

The conventional oven is provided with 3 heating elements which are:

- Top element 700 W
- Bottom element 800 W
- Grill element 1600 W

NOTE:

Upon first use, it is advisable to operate the oven for 30 minutes in the position  and for another 30 minutes at the maximum temperature (thermostat knob on position 250) in the position  to eliminate possible traces of grease on the heating elements.

WARNING:

The door is hot, use the handle.

Thermostat (Fig. 7.2)

This only sets the cooking temperature and does not switch the oven on. Rotate clockwise until the required temperature is reached (from 50 to 250°C). The light above the function selector will illuminate when the oven is switched on and turns off when the oven reaches the correct temperature. The light will cycle on and off during cooking in line with the oven temperature.

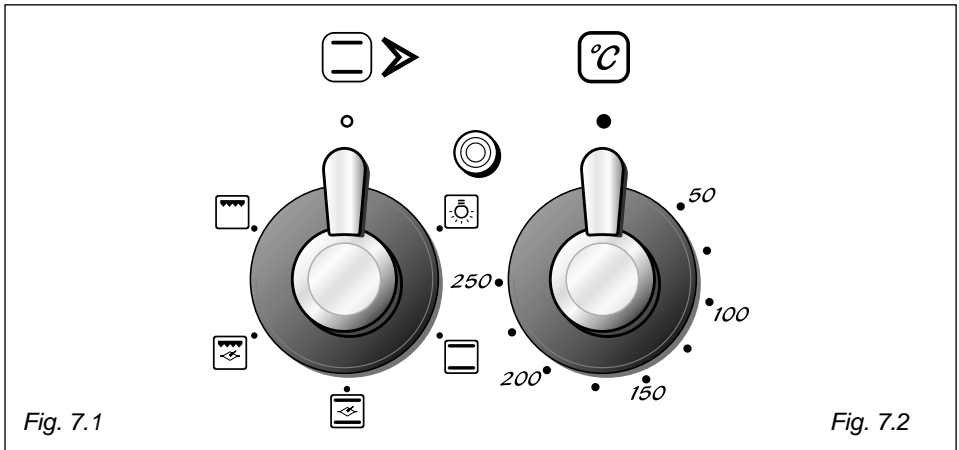

Function selector knob (fig. 7.1)

Rotate the knob clockwise to set the oven for one of the following functions.



Oven light

By setting the knob to this position, only the oven light comes on (15 W). It remains on in all the cooking modes.



Traditional convection cooking

The upper and lower heating elements come on.

The heat is dispersed by natural convection and the temperature must be set to between 50° and 250°C via the thermostat knob. The oven must be preheated before cooking.

In the  position the rotisserie motor come on for cooking with the rotisserie.

Recommended for:

Food that requires the same degree of cooking both inside and out, for example roasts, spare pork ribs, meringues etc.



Traditional grilling

The infrared electrical resistance comes on.

The heat is diffused by radiation.

Use with the oven door **closed** and the thermostat knob to position 225°C for 15 minutes then to 175°C.

In the  position the rotisserie motor come on for cooking with the rotisserie.

For cooking hints, see the chapter “**USE OF THE GRILL**”.

Recommended for:

Intense grilling, browning, cooking au gratin and toasting etc.

It is recommended that you do not grill for longer than 30 minutes at any one time.

Attention: the oven door becomes very hot during operation.

Keep children away.

Use of the grill

Switch the grill on, setting the two knobs:

- Function selector to  or  position.
- Thermostat selector to position **225°C** for 15 minutes then to **175°C**.

Leave to warm up for approximately 5 minutes with the door **closed**.

Place the food inside positioning the rack as near as possible to the grill.
Insert the drip pan under the rack to collect the cooking juices.

Grilling with the oven door closed and do not for longer than 30 minutes at any one time.

**Attention: the oven door becomes very hot during operation.
Keep children away.**

Rotisserie

The oven is equipped with a rotisserie.

This device is made up of:

- an electrical motor mounted on the rear part of the oven
- a stainless steel rod, equipped with a detachable athermic grip and 2 recordable forks
- a rod support to be inserted into the central rack holders of the oven.

Use of the rotisserie

- Insert the dripping pan into the lowest rack holders of the oven and insert the rod support into the intermediate rack holders.
- Put the meat to be cooked onto the rod, being careful to secure it in the center with the special forks.
- Insert the rod into the motor opening and rest it onto the support of the spit collar; then remove the grip by turning it to the left.

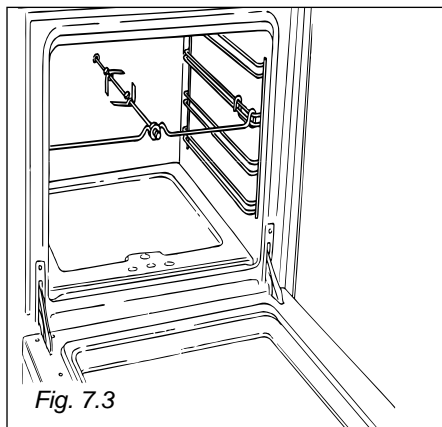

Fig. 7.3

The rotation direction of the rotisserie can be either clockwise or counter-clockwise.

Recommended cooking temperature

Food	°C	°F	Shelf Position*	Cooking Time (approx)
CAKES				
Victoria sandwich	190	375	2 or 3	20-25 mins
Small cakes/buns	190	375	1 and 2	15-20 mins
Maidera cake	180	350	2 or 3	20 mins
Fruit cake	170	325	3	1¾ hours
Rich fruit cake	150	300	3 or 4	2½ hours
Scones	225	425	2	8-10 mins
PASTRY				
Puff	225	425	2	10-20 mins
Short crust	200	400	2	20-30 mins
Plate tarts	200-210	400-410	1 or 2	30-35 mins
Quiches and flans	200-210	400-410	1 or 2	40-45 mins
YEAST				
Bread loaf	225	425	2	35-55 mins
Bread rolls	220	425	1 or 2	15-20 mins
Pizza dough	230	450	2	20 mins
ROAST MEAT				
Beef – Medium	190	375	2 or 3	20 mins/lb + 20 mins
Lamb	190	375	2 or 3	25-30 mins/b + 25 mins
Pork	190-200	375-400	2 or 3	30 mins/lb + 30 mins
Veal	190	375	2 or 3	30 mins/b + 30 mins
Chicken	190	375	2 or 3	30 mins/b + 30 mins
Turkey up to 10lb	180	350	2 or 3	18-20 mins/b + 20 mins
Stews/casseroles	150-170	300-325	2 or 3	1½ 2 hours

N.B. For fan ovens reduce the temperature by 10-20°C. For any dish taking one hour or over to cook, reduce the cooking time by 10 minutes per hour.

* Shelf positions have been counted from the top of the oven to the base. A fan oven creates more even temperature throughout, therefore the shelf positions are not as critical.

8 - Cleaning and Maintenance

GENERAL ADVICE

- When the appliance is not being used, it is advisable to keep the gas tap closed.
 - Every now and then check to make sure that the flexible tube that connects the gas line or the gas cylinder to the appliance is in perfect condition and eventually substitute it if it shows signs of wearing or damage.
 - The periodical lubrication of the gas taps must be done only by specialized personnel.
 - If a tap becomes stiff, do not force; contact your local Service Centre.
- **Important:**
Before any operation of cleaning and maintenance disconnect the appliance from the electrical network.

Attention

The appliance gets very hot, mainly around the cooking areas. It is very important that children are not left alone in the kitchen when you are cooking.

Do not use a steam cleaner because the moisture can get into the appliance thus make it unsafe.

Cleaning

All the enamelled parts must be cleaned with a sponge and soapy water or other non-abrasive products.

Dry preferably with a soft cloth.

Acidic substances like lemon juice, tomato sauce, vinegar etc. can damage the enamel if left too long.

Stainless steel surfaces

The stainless steel front panels on this cooker (facia, oven door, storage compartment) are protected by a finger-print proof lacquer.

To avoid damaging this lacquer, do not clean the stainless steel with abrasive cleaners or abrasive cloths or scouring pads.

ONLY SOAP/WARM WATER MUST BE USED TO CLEAN THE STAINLESS STEEL SURFACES.

Gas tap

If a tap becomes stiff, do not force; contact your local Service Centre.

Flexible tube

From time to time, check the flexible tube connecting the gas supply to the cooker.

It must be always in perfect condition; in case of damage arrange for it to be replaced by a C.O.R.G.I. registered installer.

Cleaning oven parts after use

The oven interior and the chromium plated shelves can be cleaned by damp soapy cloth. Obstinate stains can be removed with nylon scouring pads and gentle, non-abrasive, liquid cleaner. Provided the oven is wiped over immediately after roasting, only the minimum of cleaning should be necessary.

Burners

They can be removed and washed only with soapy water.

Detergents can be used but must not be abrasive or corrosive.

Do not use abrasive sponges or pads.

Do not put in dishwasher.

After each cleaning, make sure that the burner-caps, as well as the burners, have been well wiped off and **CORRECTLY POSITIONED**.

It is essential to check that the burner flame distributor "F" and the cap "C" has been correctly positioned (see fig. 8.1) - failure to do so can cause serious problems.

Check that the electrode "S" (fig. 8.1) is always clean to ensure trouble-free sparking.

Note:

The electrode "S" must be very carefully cleaned.

To avoid damage to the electric ignition do not use it when the burners are not in place.

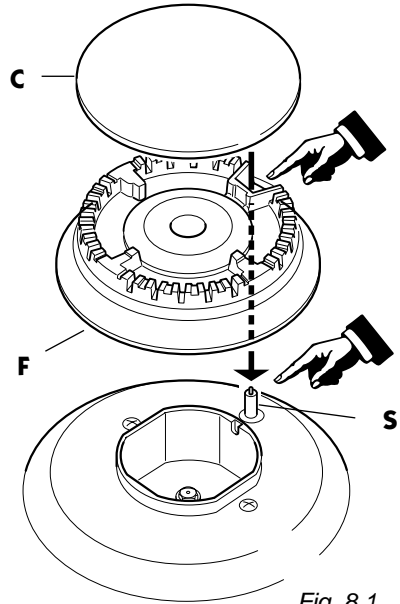

Fig. 8.1

Triple ring burners

The triple ring burner must be correctly positioned (see figs. 8.2-8.3); the burner rib must be entered in their logement as shown by the arrow.

The burner correctly positioned must not rotate (fig. 8.3).

Then position the cap **A** and the ring **B** (fig. 8.3).

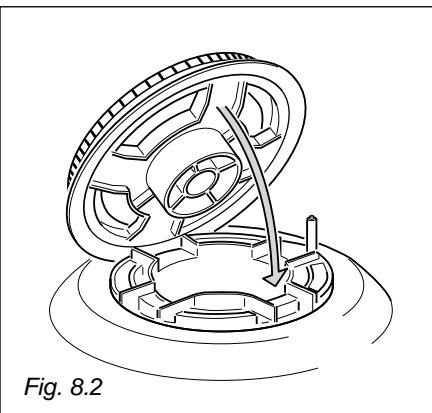

Fig. 8.2

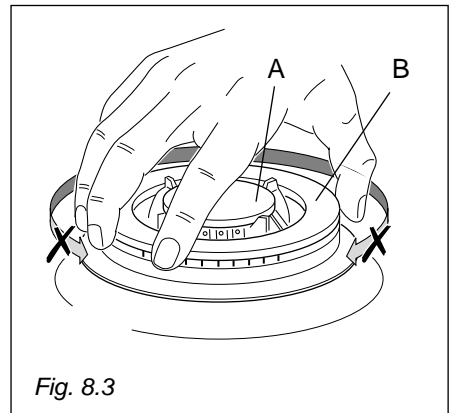
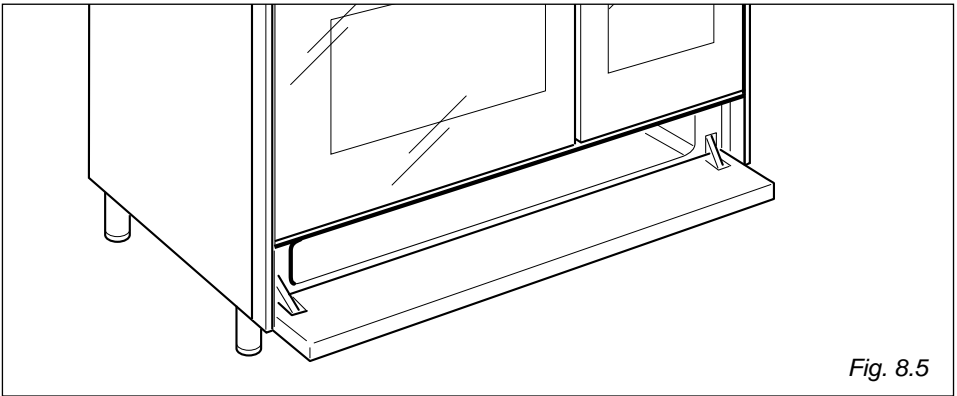
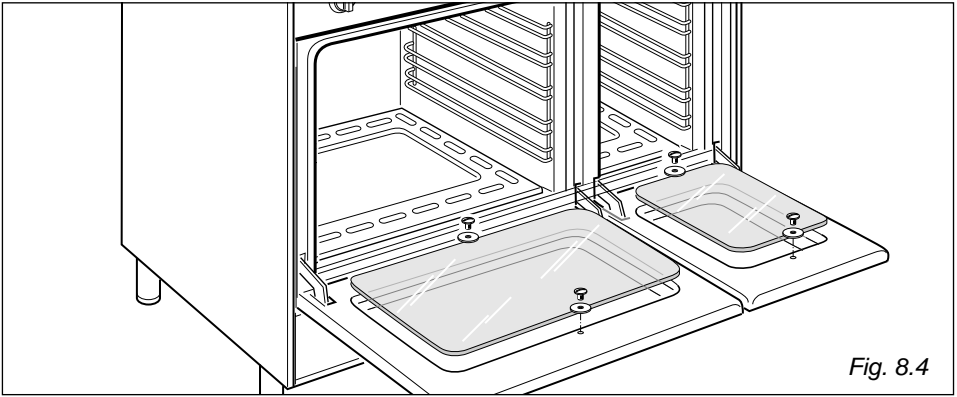

Fig. 8.3



Oven door

The internal glass panel can be easily removed for cleaning by unscrewing the retaining screws (Fig. 8.4)

Storage compartment

The storage compartment is accessible through the pivoting panel (fig. 8.5).

Do not store flammable material in the oven or in the storage compartment.

Replacing the oven light bulb

Switch the cooker off at the mains.

When the oven is cool unscrew and replace the bulb with another one resistant to high temperatures (300°C), voltage 230 V (50 Hz), 15 W, E14.

Note: Oven bulb replacement is not covered by your guarantee.

Assembly and dismantling of the side runner frames

- Fit the side runner frames into the holes on the side walls inside the oven (Fig. 8.6).
- Slide the tray and rack into the runners (Fig. 8.7).
- To dismantle, operate in reverse order.

Inside of oven

This must be cleaned regularly.

Remove and refit the side runner frames as described on the next chapter.

With the oven warm, wipe the inside walls with a cloth soaked in very hot soapy water or another suitable product. Side runner frames, tray and rack can be removed and washed.

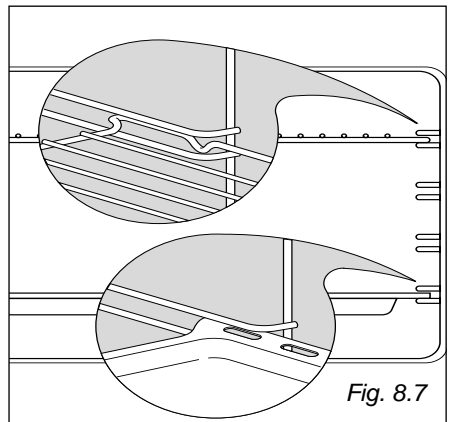
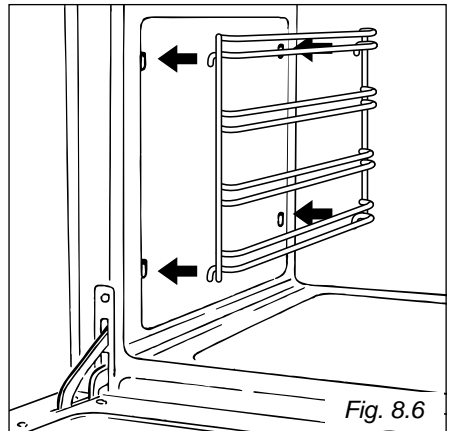

Removing the oven door

The oven door can easily be removed as follows:

- Open the door to the full extent (fig. 8.8A).
- Attach the retaining rings to the hooks on the left and right hinges (fig. 8.8B).
- Hold the door as shown in fig. 8.8.
- Gently close the door and withdraw the lower hinge pins from their location (fig. 8.8C).
- Withdraw the upper hinge pins from their location (fig. 8.8D).
- Rest the door on a soft surface.
- To replace the door, repeat the above steps in reverse order.

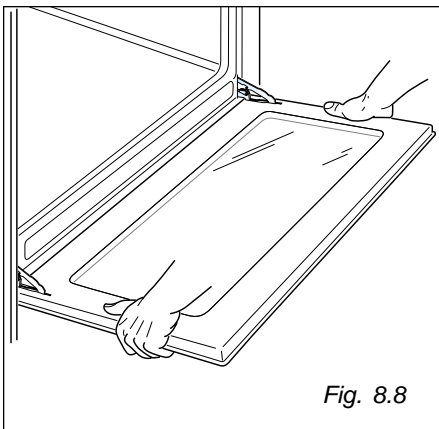
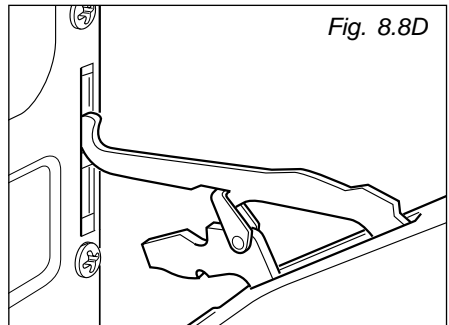
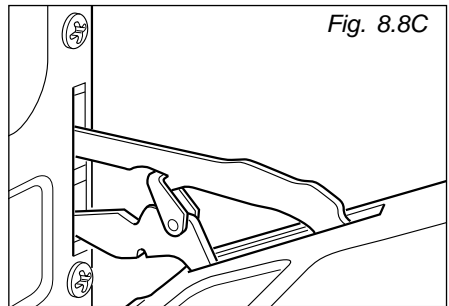
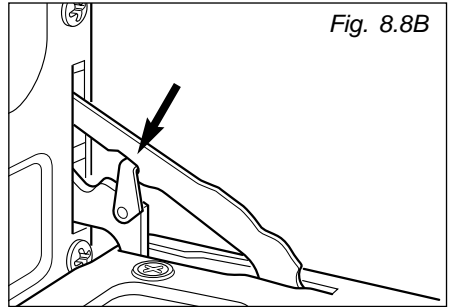
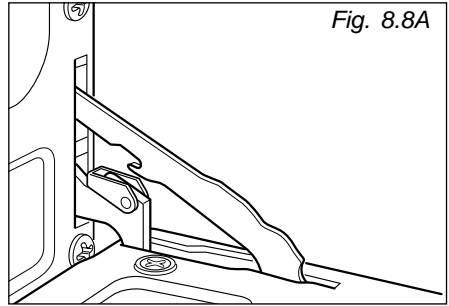

Helpful Advice

Trouble shooting

Problem

Food too brown but not cooked.

Remedy

Turn down the oven temperature slightly and cook a little longer

Problem

Food cooked but not brown enough.

Remedy

Increase temperature.

Problem

Food baking unevenly.

Remedy

1. The temperature may be slightly high turn it down
2. Position the food in the centre of the shelves rather than towards the sides of the oven.
3. Rotate the food a half turn in the oven.
4. Try pre-heating the oven for 5-15 minutes prior to baking.

Always remove cooked items as soon as they are ready and continue cooking the under-cooked items until they are completely finished.

Changing the Oven Cavity Light Bulb.

If the oven light falls:

1. Turn off the oven by switching the oven selector to 0, switch off at the cooker point.
2. When the oven is cool, reach back and upwards inside the oven, the bulb is in the top corner.
3. Unscrew the light glass cover, replace the bulb with a new one of the same specification and screw the cover back until it is hand tight.

NOTE: Oven bulb replacement is not covered by your guarantee.

Other bulbs cannot be changed by yourself and should be replaced by an authorised CAPLE Service Engineer.

Bulbs other than the oven bulb are covered by the guarantee.

IMPORTANT: Ovens get hot. Keep children away from this appliance at all times.

If Your Oven Does Not Work

Before calling a CAPLE service engineer run through the following checklist.

1. The cooker is connected to the power supply and that the fuse is intact.
2. Make sure the timer control (main oven only) is set to the manual position, and that the oven has not been set inadvertently for an automatic or timed programme.

If you are in any doubt about carrying out these checks, call the **CAPLE Helpline on 0870 241 1142.**

A charge will be made if the appliance is found to be in working order, or if it has not been installed in accordance with these instructions, or if it is has been used incorrectly.

CAPLE "Built-in" Service

Should you require service at any time, please contact the **Caple Helpline on 0870 241 1142.**

Caple have a nationwide service network of engineers who will respond quickly to your call.

Always replace spare parts with genuine **Caple** spares. These are available from authorised **Caple Service Centres** or by mail order from our **National Service Stores, simply telephone 0870 241 1142.**

When ordering parts always quote the model number and serial number of your appliance.

YOUR GUARANTEE

CAPLE guarantees all parts of this product for one year from the date of purchase. During that time, should it become necessary CAPLE engineers will replace or repair all defective parts free of charge, except for parts subject to fair wear and tear, such as lightbulbs.

Parts and the engineers labour costs are chargeable after the first 12 months.

To qualify for benefits under the guarantee, you must be able to provide proof of date of purchase and the appliance must have been supplied, installed and used for domestic purposes only in accordance with CAPLE instructions.

Consequential losses and accidental damage to the product are not covered by the guarantee.

This guarantee does not affect your statutory or common law rights.

CAPLE cannot be responsible for the results of using this appliance for any other purposes other than those described in these instructions.