



# **C502M/SS**

**Caple Multi Function Oven  
Stainless Steel**

**INSTRUCTION MANUAL**

Thank you for buying your new CAPLE Cooker. To ensure that you get the best results from your new CAPLE Cooker, we strongly suggest that you read this instruction manual thoroughly before use. This manual contains installation advice, cleaning tips and a cooking guide, as well as other important facts about your CAPLE cooker. If treated with care, your CAPLE appliance should give you years of trouble-free cooking.

**For Spare Parts, Technical Advice  
or Product Service call the  
CAPLE HELPLINE on 0870 241 1142**

(Answerphone outside office hours)

The **CE** marking confirms that the appliance conforms to the following EU directives:

- safety requirements of EEC Directive "Gas" 90/396;
- safety requirements of EEC Directive "Low voltage" 73/23;
- protection requirements of EEC Directive "EMC" 89/336;
- requirements of EEC Directive 93/68.

# Safety Reminders

---

## Instruction Book

This appliance should only be used for its intended purpose as described in these instructions.

Ensure that you fully understand these instructions before operating this appliance.

## Space Requirements

Ensure that the specified ventilation space around the appliance is not obstructed.

## Food Splashes

Always wipe clean the oven after use. Food splashes can carry on cooking next time and may become a fire hazard.

## Hot Surfaces

It is important to remember that the surfaces of cooking appliances get hot during use and retain the heat for some time after switching off.

It is therefore advisable to keep small children away from the appliance.

## The Grill and Top oven element

are exposed, so take great care when placing food in the oven or removing it. Use the grill pan handles or gloves.

**DO NOT** line the oven, grids, trays etc. with aluminium foil as this could adversely affect the heating elements and it could also damage the interior surfaces.

**DO NOT** place flammable materials in the oven or in the drawer.

## Faults

Do not continue to use this appliance if it appears to be faulty.

## After Use

Switch the appliance controls off. Always switch off at the isolating switch before cleaning the appliance, or attempting any maintenance task, or when not in use for long periods (when on holiday).

## CAPLE Service

To ensure the continued safe and efficient operation of this appliance, we recommend that any servicing or repairs are carried out only by an authorised CAPLE SERVICE ENGINEER.

# Electrical Requirements

---

**WARNING!**  
**ELECTRICITY CAN BE EXTREMELY DANGEROUS.**  
**THIS APPLIANCE MUST BE EARTHED.**

## **For your safety please read the following information:**

This appliance must be installed by a qualified technician according with the current local regulations and in compliance with the manufacturer instructions.

This appliance is supplied with a moulded 13 amp three pin mains plug with a 13 amp fuse fitted. Should the fuse require replacement, it must be replaced with a fuse rated at 13 amp and approved by ASTA or BSI to BS 1362.

**IF THE MOULDED MAINS PLUG IS UNSUITABLE FOR THE SOCKET OUTLET IN YOUR HOME OR IS REMOVED FOR ANY OTHER REASON, THEN THE FUSE SHOULD BE REMOVED AND THE CUT OFF PLUG DISPOSED OF SAFELY TO PREVENT THE HAZARD OF ELECTRIC SHOCK.**

**THERE IS A DANGER OF ELECTRICAL SHOCK IF THE CUT OFF PLUG IS INSERTED INTO ANY 13 AMP SOCKET OUTLET.**

If a replacement plug is to be fitted, please observe the wiring code shown below.

A properly earthed three pin plug (fused at 13 amps, to BS 1362 ASTA approved) must be used. As the colours of the wires in the mains lead of this appliance may not correspond with the coloured markings identifying the terminals in your plug, proceed as follows.

The wire which is coloured **GREEN & YELLOW** must be connected to the terminal in the plug which is marked with letter "E" or by the Earth symbol or coloured **GREEN & YELLOW**.

The wire which is coloured **BLUE** must be connected to the terminal which is marked with the letter "N" or coloured **BLACK**.

The wire which is coloured **BROWN** must be connected to the terminal which is marked with the letter "L" or coloured **RED**.

# 1 - Electrical Installation - Wall box connection

This appliance must be connected to a double pole isolating switch (fig. 1.1) and to the terminal block in the cooker (figs. 1.2 & 1.3) using the following guide:

- 1) The wire which is coloured brown must be connected to the terminal marked **L** (Live), or coloured Red.
- 2) The wire which is coloured blue must be connected to the terminal marked **N** (Neutral), or coloured Black.
- 3) The wire which is coloured green and yellow must be connected to the terminal marked **E** (Earth)  $\text{⏏}$  or coloured Green.

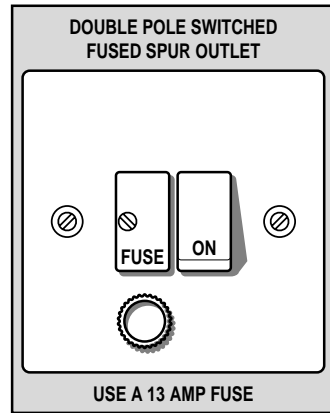

Fig. 1.1

**IMPORTANT:** These connections must be carried out by a qualified electrical engineer.

## CONNECTING FEEDER CABLE

To connect the feeder cable to the cooker it is necessary to:

- Remove the screw that hold shield “A” behind the cooker (fig. 1.2).
- Insert the feeder cable of the suitable section (as described in the next chapter) into the cable clamp “B”.
- Connect the phase and earth cables to the terminal block “B” according to the diagram in figure 3.
- Pull the feeder cable and block it with cable clamp “D”.
- Re-mount shield “A”.

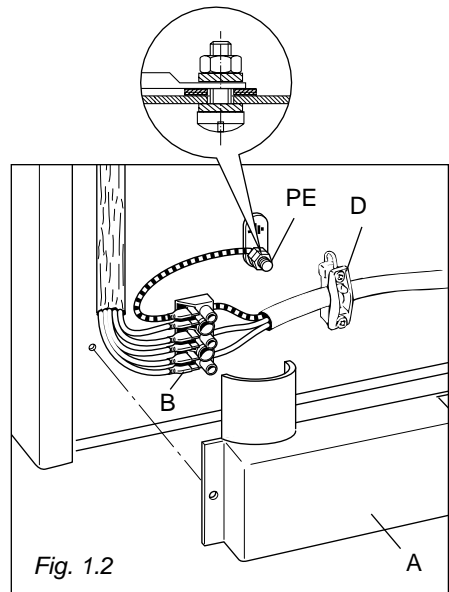

Fig. 1.2

## FEEDER CABLE SECTION type H05VV-F or H05RR-F

230 V  $\sim$  3 x 1,5 mm<sup>2</sup>

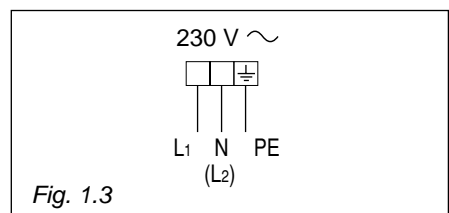

Fig. 1.3

# FOR THE INSTALLER

## 2 - Location

The cooker must be installed by a qualified technician and in compliance with local safety standards.

This cookers has class “2/1” overheating protection so that it can be installed in a cabinet. If the cooker is installed adjacent to furniture which is higher than the cooktop, a gap of at least 50 mm must be left between the side of the cooker and the furniture (fig. 2.1).

The furniture walls adjacent to the cooker must be made of material resistant to heat.

The veneered syntetical material and the glue used must be resistant to a temperature of 120°C in order to avoid ungluing or deformations.

The cooker may be located in a kitchen, a kitchen/diner or bed-sitting room but not in a room containing a bath or shower.

Curtains must not be fitted immediatly behind appliance or within 500 mm of the sides.

It is essential that the cooker is positioned as stated below.

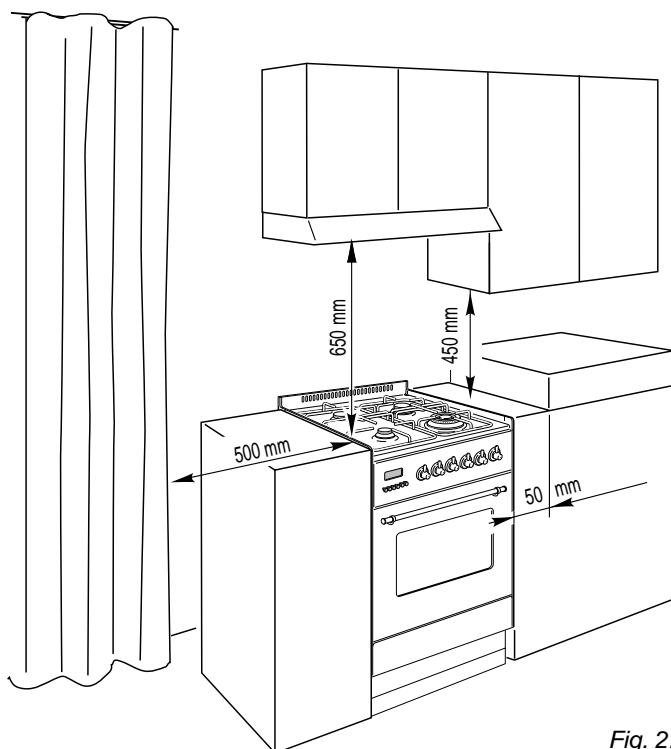

Fig. 2.1

## ASSEMBLING THE BACKGUARD

Before assembling remove any protective film/adhesive tape.

The backguard B and the side supports S and D can be found packed in the drawer.

1. Insert the side supports **S** and **D** into the backguard **B** (see fig. 2.2)
2. Insert the backguard group into the support guides in the cooker
3. The backguard can be removed for cleaning or fixed with a screw through the hole **C**.

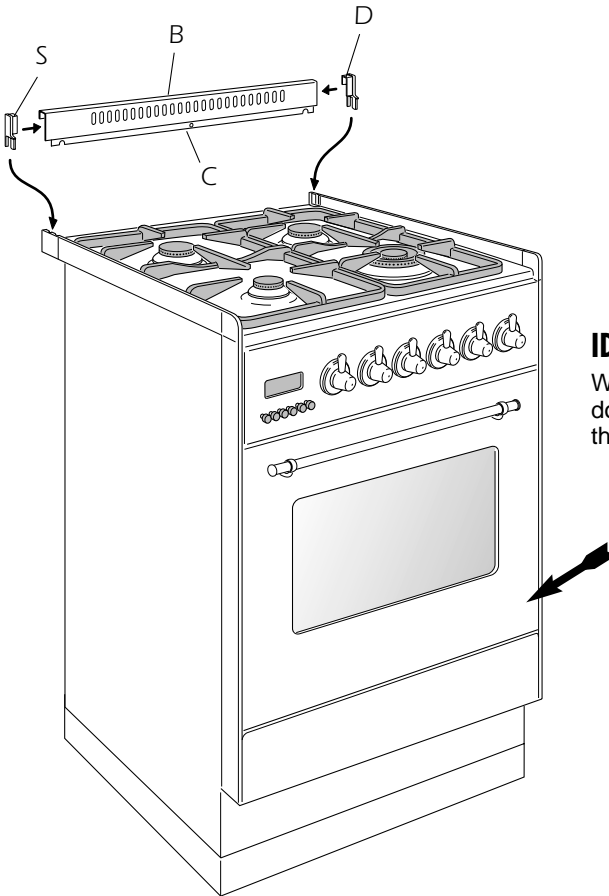

### IDENTIFICATION LABEL

When you open the bottom oven door the identification label is at the bottom right hand side.

Fig. 2.2

## LEVELLING

The cooker is equipped with a 4 levelling feet which must be fitted to the base of the cooker in the following manner:

- Place the cooker on its back as shown in the figure 2.3.
- Screw the 4 leveling feet to the cooker.
- Stand the cooker and levelling it by screwing or unscrewing the feet with a spanner.

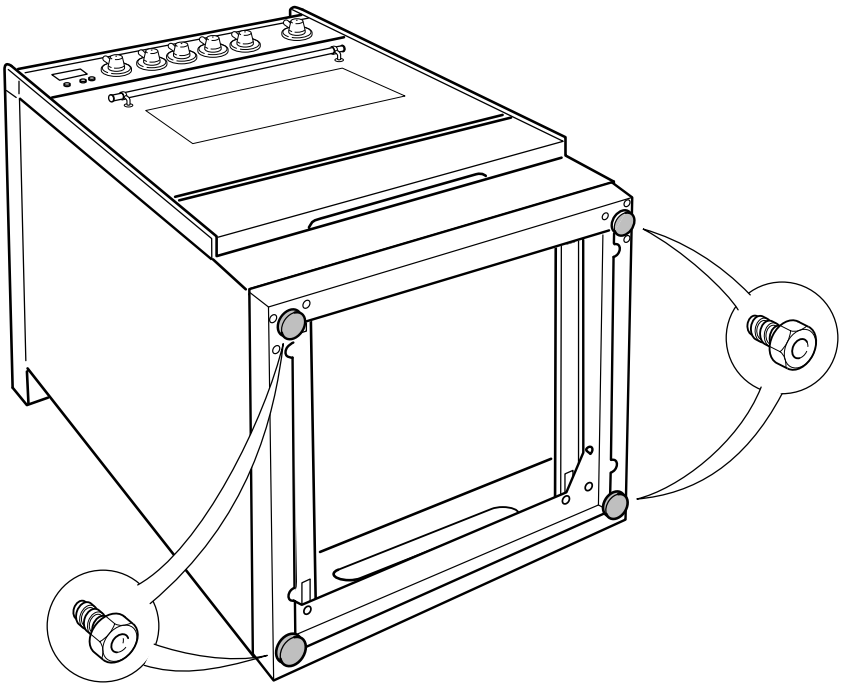

# Provision for ventilation

The room containing the cooker should have an air supply in accordance with BS.5540: Part 2: 1989.

All rooms require an openable window or equivalent while some rooms require a permanent vent in addition to the openable window.

The cooker should not be installed in a bed-sitting room, of volume less than 21 m<sup>3</sup>.

Where a DOMESTIC COOKER is installed in a room or internal space, that room or internal space shall be provided with a permanent opening which communicates directly with outside air and is sized in accordance with table below. In domestic premises the permanent opening shall be an air vent.

If there are other fuel burning appliances in the same room, BS.5540: Part 2: 1989 should be consulted to determine the requisite air vent requirements.

If the cooker is installed in a cellar or basement, it is advisable to provide an air vent of effective area 100 cm<sup>2</sup>, irrespective of the room volume.

MINIMUM PERMANENT OPENING FREE AREA FOR FLUELESS APPLIANCE						
Type of appliance	Maximum appliance rated input limit	Room volume				Openable window or equivalent also required
		< 5 m <sup>3</sup>	5 m <sup>3</sup> to 10 m <sup>3</sup>	11 m <sup>3</sup> to 20 m <sup>3</sup>	> 20 m <sup>3</sup>	
Domestic oven, hotplate, grill or any combination thereof.	None	100 cm <sup>2</sup>	50 (*) cm <sup>2</sup>	Nil cm <sup>2</sup>	Nil cm <sup>2</sup>	Yes

(\*) If the room or internal space containing these appliances has a door which opens directly to outside, no permanent opening is required.

## 3 - Gas connection

---

### **GAS INSTALLATION**

#### **IMPORTANT NOTE**

This appliance is supplied for use on NATURAL GAS only and cannot be used on any other gas without modification.

This appliance is manufactured for conversion to LPG if required and is supplied with a conversion kit.

The cooker must be installed by a qualified person in accordance with the Gas Safety (Installation and Use) (Amendment) Regulation 1990 and the relevant building/I.E.E. Regulations.

The following British Standards should be used as reference when installing this appliance.

BS6172 1990, BS5440 part 2 1989 and BS6891 1988.

Failure to install the appliance correctly could invalidate any manufacturers warranty and lead to prosecution under the above quoted regulation.

In the UK C.O.R.G.I registered installers are authorised to undertake the installation and service work in compliance with the above regulations.

### **GAS CONNECTION**

The installation of the cooker to Natural Gas or LP Gas must be carried out by a qualified gas engineer. Installers shall take due account of the provisions of the relevant British Standards Code of Practice, the Gas Safety Regulations and the Building Standards (Scotland) (Consolidation) Regulations issued by the Scottish Development Department.

#### **INSTALLATION TO NATURAL GAS**

Installation to Natural Gas must conform to the Code of Practice, etc. The supply pressure for Natural Gas is 20 mbar.

#### **INSTALLATION TO LP GAS**

This appliance must only be connected to LPG after an LPG conversion kit has been fitted, (see pages from 11 to 14).

When operating on Butane gas a supply pressure of 28-30 mbar is required.

When using Propane gas a supply pressure of 37 mbar is required.

The installation must conform to the relevant British Standards.

Warning: Only a qualified gas engineer, also with technical knowledge of electricity should install the cooker. He should observe the Regulations and Codes of Practice governing such installation of gas cookers.

Note: It is recommended that the gas connection to the cooker is installed with a flexible connecting tube made to BS 5386.

## GAS CONNECTION

The gas supply must be connected to the gas inlet which is located at the left or the right hand rear of the appliance (fig. 3.1).

The pipe does not cross the cooker.

When screwing the connecting tube operate with two spanners (fig. 3.2).

The unused end inlet pipe must be closed with the plug, interposing the gasket.

After connecting to the mains, check that the coupling are correctly sealed, using soapy solution, but never a flame.

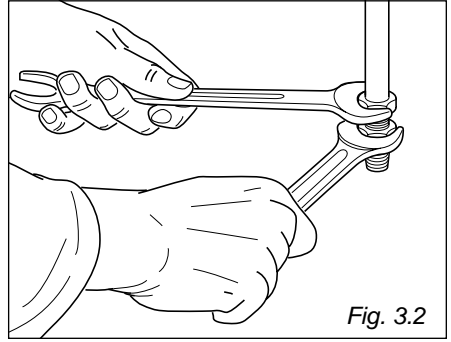

*Fig. 3.2*

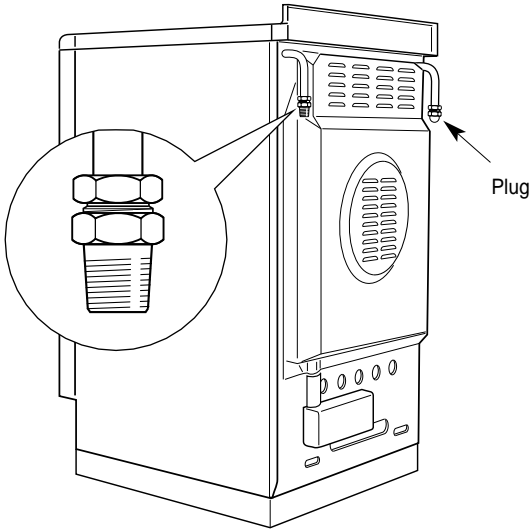

*Fig. 3.1*

# 1 - Injectors replacement of top burners

This appliance is suitable for use with natural gas or LPG (check the “gas type” sticker attached to the appliance).

The nominal gas consumption and injector size details are provided in table at page 15.

To replace the injectors it is necessary to lift the cooktop and proceed as follows:

- Remove the backguard “G” (Fig. 3.3).
- Remove pan supports and burners from the cooktop.
- Unscrew the two screws “B” and remove the sockets (Fig. 3.3).
- Unscrew the two screws “C” and remove the two side trims and joints pulling upwards.
- Pull forwards the hobtop to release it, then lift following arrow “D” (Fig. 3.3).
- Hold the hobtop open by a support (Fig. 3.4).
- Fully raise the adjusting air tube A (fig. 3.5) in order to easily reach the injector.
- Using a 7 mm A/F angled spanner, remove the injector from its housing and replace it one according to the kind of gas (see following tables - page 15).

Flame faulty in primary air	Flame correct	Flame with excess primary air
long, yellow and trembling	clear interior blue cone	short and sharp too blue interior cone tending to detach
CAUSE		
air regulating tube, too closed	correct distance of the tube	air regulating tube, too open

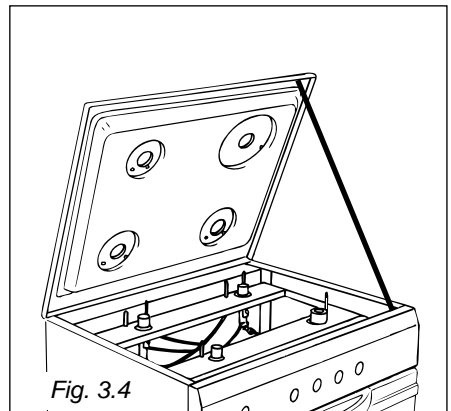
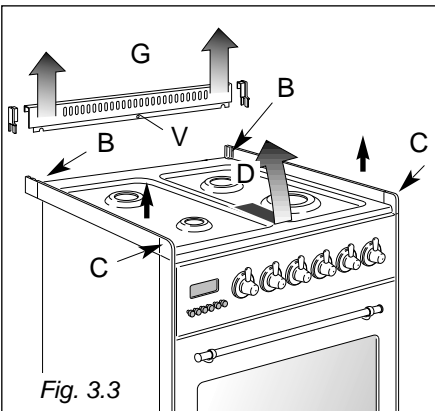

## 2 - Adjusting of primary air of the top burners

By operating the screw “M”, reset the air adjuster “A” according to the instructions see “TABLE FOR THE CHOICE OF THE INJECTORS”, where the distance between injector and air adjuster is recommended (in mm).

Before lowering the hob top, set the burners on their sites and light them in order to check whether the flames are correct, as per the specifications given at page 12.

In case of uncorrect flame, lift or lower the air adjuster.

## 3 - Adjusting of the minimum of the top burners

Considering that in the minimum position the flame must have a length of about 4 mm and must remain lit even with a brusque passage from the maximum position to that of minimum.

The flame adjustment is done in the following way:

- Turn on the burner
- Turn the tap to the MINIMUM position
- Take off the knob
- With a small flat screwdriver turn the screw inside the tap rod to the correct regulation (fig. 3.6).

Normally for LPG, tighten up the regulation screw.

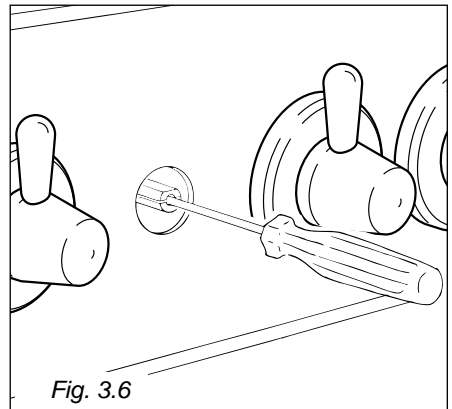
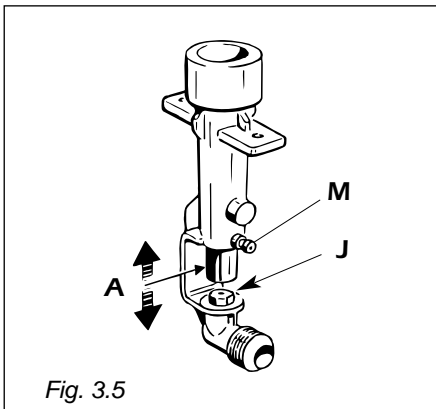

BURNERS	Nominal Power [kW]	Reduced Power [kW]	G 30 - 28-30 mbar G 31 - 37 mbar			G 20 20 mbar		
			By-pass [1/100 mm]	Ø injector [1/100 mm]	Ring opening [mm]	By-pass [1/100 mm]	Ø injector [1/100 mm]	Ring opening [mm]
Auxiliary (A)	1,00	0,30	27	50	3 *	adjustable	72	1 *
Semi-rapid (SR)	1,90	0,38	29	67	5,7 *		100	2 *
Double-ring	3,45	0,85	47	92	fully open *		135	5 *

\* = Reference value

INCREASE OF AIR NECESSARY FOR GAS COMBUSTION (2 m <sup>3</sup> /h x kW)	
BURNERS	Air necessary for combustion [m <sup>3</sup> /h]
Auxiliary (A)	2,00
Semi-rapid (SR)	3,80
Double-ring	6,90

## Lubrication of the gas taps

If the gas tap becomes stiff, it is necessary to dismount it accurately clean it with gasoline and spread a bit of special grease resistant to high temperatures on it.

The operations must be executed by a qualified technician.

## 4 - Features and Technical Data

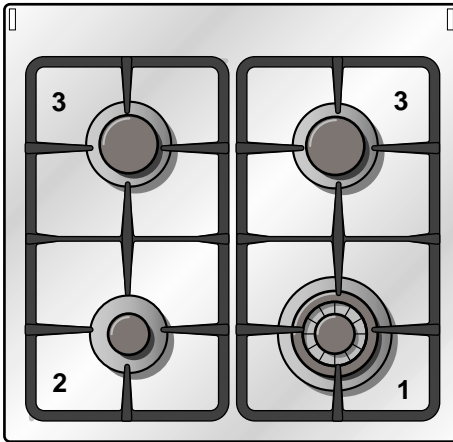

### COOKING HOB - (Fig. 4.1)

- |                            |         |
|----------------------------|---------|
| 1. Double-ring burner (PB) | 3,45 kW |
| 2. Auxiliary burner (A)    | 1,00 kW |
| 3. Semi-rapid burner (SR)  | 1,90 kW |

Fig. 4.1

Fig. 4.2

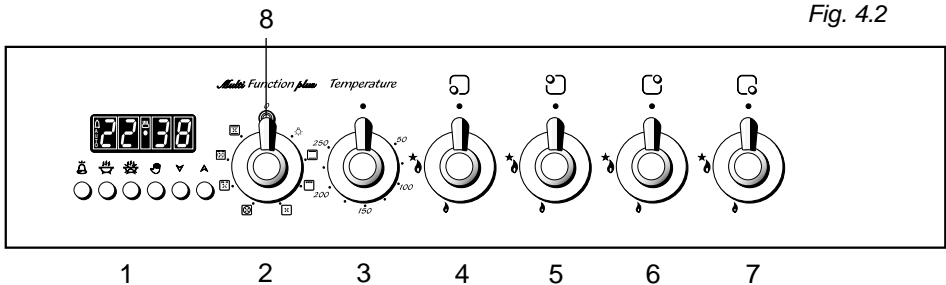

### Control panel - (Fig. 4.2)

1. Digital electronic programmer
2. Multifunction oven switch knob
3. Multifunction oven thermostat knob
4. Front left burner control knob
5. Rear left burner control knob
6. Rear right burner control knob
7. Front right burner control knob
8. Temperature indicator light

# How To Use the Hob Burners

---

## Hob burners



Each hob burner is controlled by a separate gas tap operated by a control knob (fig. 4.3) which has 3 positions marked on the knob, these are:

– Symbol ● : tap closed (burner off)

– Symbol  : High (maximum)

– Symbol  : Low (minimum)

Push in and turn the knob anti-clockwise to the selected position.

 Low       High

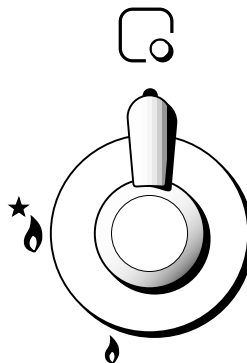

Fig. 4.3

To turn the burner off, fully rotate the knob clockwise to the off position: ●.

The maximum setting of the control tap is for boiling, the minimum setting is for slow cooking and simmering.

All working positions must be chosen between the maximum and minimum setting, never between the maximum setting and the “OFF” position.

## Lighting of the hob burners

To ignite the burner, the following instructions are to be pursued:

- 1) Lightly press and turn the knob anti-clockwise, and make the symbol  printed on the knob to match with the indicator on the control panel (fig. 4.3).
- 2) Press the knob to operate the electric ignition; or, in case of power cut, approach a flame to the burner.
- 3) Adjust the burner according to the power required.

## Electric ignition

The sparks generated by the electrodes close to the burners will ignite the chosen burner. Whenever the lighting of the burners will result difficult due to peculiar conditions of the gas features or supply, it is advised to repeat the ignition with the knob on “minimum” position.

# Choice of burner

---

The burner must be chosen according to the diameter of the pans and energy required.

Burners	Pan diameter
Auxiliary	12 ÷ 16 cm
Semi-rapid	16 ÷ 22 cm
Double-ring	up to 30 cm
Wok	max 36 cm

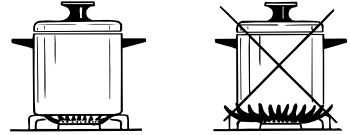

*Fig. 4.4*

Saucepans with handles which are excessively heavy, in relationship to the weight of the pan, are safer as they are less likely to tip.

Pans which are positioned centrally on burners are more stable than those which are off-set.

It is far safer to position the pan handles in such a way that they cannot be accidentally knocked.

When deep fat frying fill the pan only one third full of oil.

**DO NOT** cover the pan with a lid and **DO NOT** leave the pan unattended.

In the unfortunate event of a fire, leave the pan where it is and turn off all controls.

Place a damp cloth or correct fitting lid over the pan to smother the flames.

**DO NOT** use water on the fire.

Leave the pan to cool for at least 30 minutes.

## CORRECT USE OF DOUBLE-RING BURNER

The flat-bottomed pans are to be placed directly onto the pan-support.

When using a WOK you you need to place the supplied stand in the burner to avoid any faulty operation of the double-ring burner.

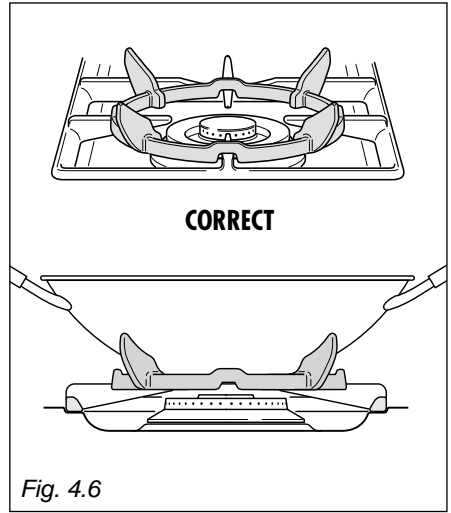
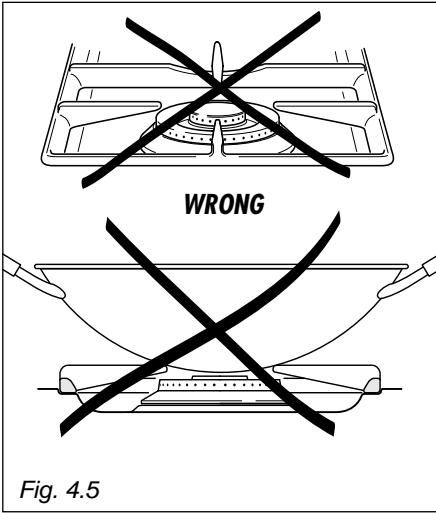

# 6 - How To Use the Multi-function oven

---

**Attention: the oven door becomes very hot during operation. Keep children away.**



As its name indicates, this is an oven that presents particular features from an operational point of view.

In fact, it is possible to insert 7 different programs to satisfy every cooking need. The 7 positions, thermostatically controlled, are obtained by 4 heating elements which are:

– Bottom element	1400 W
– Top element	1000 W
– Grill element	2000 W
– Circular element	2500 W
– Fan motor	25 W
– Oven lamp	15 W

– Usable oven volume 59 dm<sup>3</sup>

## NOTE:

Upon first use, it is advisable to operate the oven for 30 minutes in the position  and for another 15 minutes at the maximum temperature (thermostat knob on position 250) in the positions  and , to eliminate possible traces of grease on the heating elements.

Clean the oven and accessories with warm water and washing-up liquid.

## WARNING:

**The door is hot use the handle.**

## OPERATING PRINCIPLES

Heating and cooking in the MULTI-FUNCTION oven are obtained in the following ways:

### a. by normal convection

The heat is produced by the upper and lower heating elements.

### b. by forced convection

A fan sucks in the air contained in the oven muffle, which sends it through the circular heating element and then sends it back through the muffle. Before the hot air is sucked back again by the fan to repeat the described cycle, it envelops the food in the oven, provoking a complete and rapid cooking.

It is possible to cook several dishes simultaneously.

### c. by semi-forced convection

The heat produced by the upper and lower heating elements is distributed throughout the oven by the fan.

### d. by radiation

The heat is irradiated by the infra red grill element.

### e. by radiation and ventilation

The irradiated heat from the infra red grill element is distributed throughout the oven by the fan.





## GRILLING

The infra-red heating element is switched on. The heat is diffused by radiation. Set the thermostat knob to between 50° and 200°C.

Always grill with the oven door closed.

**Note: It is recommended that you do not grill for longer than 30 minutes at any one time.**

**Attention: the oven door becomes very hot during operation. Keep children away.**

### RECOMMENDED USE:

Intense grilling action for cooking with a broiler; browning, crisping, "au gratin", toasting, etc.



## HOT AIR COOKING

The circular element and the fan are on. The heat is diffused by forced convection and the temperature must be regulated between 50° and 250 °C with the thermostat knob.

It is not necessary to preheat the oven.

### RECOMMENDED USE:

For foods that must be well done on the outside and tender or rare on the inside, i. e. lasagna, lamb, roast beef, whole fish, etc.



## DEFROSTING FROZEN FOODS

Only the oven fan is on.

To be used with the thermostat knob on "●" because the other positions have no effect. The defrosting is done by simple ventilation without heat.

### RECOMMENDED USE:

To rapidly defrost frozen foods; 1 kilogram requires about one hour.

The defrosting times vary according to the quantity and type of foods to be defrosted.



## VENTILATED GRILL COOKING

The infra-red ray grill and the fan are on. The heat is mainly diffused by radiation and the fan then distributes it throughout the oven. The temperature must be regulated between 50° and 175 °C **for max 30 minutes**, with the thermostat knob.

It is necessary to preheat the oven for about 5 minutes.

**Attention: the oven door becomes very hot during operation. Keep children away.**

### RECOMMENDED USE:

For grill cooking when a fast outside browning is necessary to keep the juices in, i. e. veal steak, steak, hamburger, etc.



## MAINTAINING TEMPERATURE AFTER COOKING OR SLOWLY HEATING FOODS

The upper element and the circular element connected in series, are switched on; also the fan is on.

The heat is diffused by forced convection with the most heat being produced by the upper element.

The temperature must be regulated between 50° and 140 °C with the thermostat knob.

### RECOMMENDED USE:

To keep foods hot after cooking. To slowly heat already cooked foods.



## CONVECTION COOKING WITH VENTILATION

The upper and lower heating elements and the fan turn on.

The heat coming from the top and bottom is diffused by forced convection.

The temperature must be regulated between 50° and 250 °C with the thermostat knob.

### RECOMMENDED USE:

For foods of large volume and quantity which require the same internal and external degree of cooking; for ie: rolled roasts, turkey, legs, cakes, etc.

## COOKING ADVICE

### STERILIZATION

Sterilization of foods to be conserved, in full and hermetically sealed jars, is done in the following way:

- a. Set the switch to position
- b. Set the thermostat knob to position 185 °C and preheat the oven.
- c. Fill the dripping pan with hot water.
- d. Set the jars onto the dripping pan making sure they do not touch each other and the door and set the thermostat knob to position 135 °C.

When sterilization has begun, that is, when the contents of the jars start to bubble, turn off the oven and let cool.

### REGENERATION

Set the switch to position

and the thermostat knob to position 150° C. Bread becomes fragrant again if wet with a few drops of water and put into the oven for about 10 minutes at the highest temperature.

## GRILLING AND “AU GRATIN”

Set the switch to position .

Set the thermostat to position 175 °C and after having preheated the oven, simply place the food on the shelf.

Close the door and let the oven operate with the thermostat on, until grilling is complete.

Adding a few dabs of butter before the end of the cooking time gives the golden “au gratin” effect.

**Note: It is recommended that you do not grill for longer than 30 minutes at any one time.**



**ATTENTION: the oven door becomes very hot during operation. Keep children away.**

## ROASTING

To obtain classical roasting, it is necessary to remember:

- that it is advisable to maintain a temperature between 180 and 200 °C.
- that the cooking time depends on the quantity and the type of foods.

## SIMULTANEOUS COOKING OF DIFFERENT FOODS

The MULTI-FUNCTION oven set on position  and  gives simultaneous heterogeneous cooking of different foods.

Different foods such as fish, cake and meat can be cooked together without mixing the smells and flavours.

This is possible since the fats and vapors are oxidized while passing through the electrical element and therefore are not deposited onto the foods.

The only precautions to follow are:

- The cooking temperatures of the different foods must be as close to as possible, with a maximum difference of 20° - 25 °C.
- The introduction of the different dishes in the oven must be done at different times in relation to the cooking times of each one.

The time and energy saved with this type of cooking is obvious.

## USE OF THE GRILL

Preheat the oven for about 5 minutes.

Introduce the food to be cooked, positioning the rack as close to the grill as possible.

The drip pan should be placed under the rack to catch the cooking juices and fats.

**Grilling with the oven door closed.**

**Do not grill for longer than 30 minutes at any one time.**

**CAUTION: the oven door becomes very hot during operation. Keep children well out of reach.**

# Recommended cooking temperature

Food	°C	°F	Gas Mark	Shelf Position*	Cooking Time (approx)
<b>CAKES</b>					
Victoria sandwich	190	375	5	2 or 3	20-25 mins
Small cakes/buns	190	375	5	1 and 2	15-20 mins
Maidera cake	180	350	4	2 or 3	20 mins
Fruit cake	170	325	3	3	1 <sup>3</sup> / <sub>4</sub> hours
Rich fruit cake	150	300	2	3 or 4	2 <sup>1</sup> / <sub>2</sub> hours
Scones	225	425	8-9	2	8-10 mins
<b>PASTRY</b>					
Puff	225	425	8-9	2	10-20 mins
Short crust	200	400	6	2	20-30 mins
Plate tarts	200-210	400-410	6	1 or 2	30-35 mins
Quiches and flans	200-210	400-410	6	1 or 2	40-45 mins
<b>YEAST</b>					
Bread loaf	225	425	7-8	2	35-55 mins
Bread rolls	220	425	7	1 or 2	15-20 mins
Pizza dough	230	450	8	2	20 mins
<b>ROAST MEAT</b>					
Beef – Medium	190	375	5	2 or 3	20 mins/lb + 20 mins
Lamb	190	375	5	2 or 3	25-30 mins/b + 25 mins
Pork	190-200	375-400	5-7	2 or 3	30 mins/lb + 30 mins
Veal	190	375	5	2 or 3	30 mins/b + 30 mins
Chicken	190	375	5	2 or 3	30 mins/b + 30 mins
Turkey up to 10lb	180	350	4	2 or 3	18-20 mins/b + 20 mins
Stews/casseroles	150-170	300-325	2-3	2 or 3	1 <sup>1</sup> / <sub>2</sub> 2 hours

**N.B.** For fan ovens reduce the temperature by 10-20°C. For any dish taking one hour or over to cook, reduce the cooking time by 10 minutes per hour.







\* Shelf positions have been counted from the top of the oven to the base. A fan oven creates more even temperature throughout, therefore the shelf positions are not as critical.

# 7 - Electronic programmer

The electronic programmer is a device which groups together the following functions:

- 24 hours clock with illuminated display
- Timer (up to 23 hours and 59 minutes)
- Program for automatic oven cooking
- Program for semi-automatic oven cooking.

## Description of the buttons:

-  Timer
-  Cooking time
-  End of cooking time
-  Manual position and cancellation of the inserted cooking program
-  Advance of the numbers of all programs
-  Turning back of the numbers of all programs and changing the frequency of the audible signal.



Automatic cooking taking place





Timer in operation



and **AUTO** - flashing - Program error.

(The time of day lies between the calculated cooking start and end time).

## Note:

Select a function by the respective button and, in 5 seconds, set the required time with the  /  buttons ("one-hand" operation).

A power cut makes the clock go to zero and cancels the set programs.

## Description of the lighted symbols:

**AUTO** - *flashing* - Programmer in automatic position but not programmed

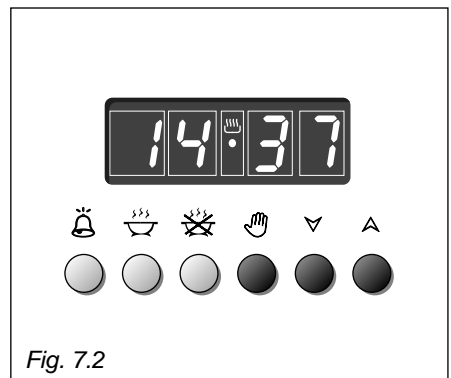
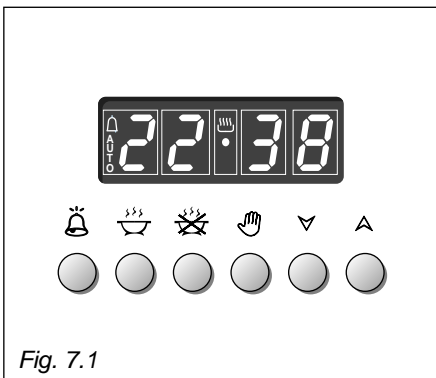

**AUTO** - *always lighted* - Programmer in automatic position with program inserted.







## ELECTRONIC CLOCK (fig. 7.2)

The programmer is equipped with an electronic clock with lighted numbers which indicates hours and minutes.



Upon immediate connection of the oven or after a power cut, three zeros will flash on the programmer panel.

To set the hour it is necessary to push the  button and then the  or  button until you have set the exact hour (fig. 7.2).

Another way is to simultaneously push the   two buttons and at the same time push the  or  button.

**Nota:** Changing the hour button deletes any cooking program.

## NORMAL COOKING WITHOUT THE USE OF THE PROGRAMMER

To manually use the oven, that is, without the aid of the programmer, it is necessary to cancel the flashing AUTO by pushing the button  (AUTO will be switched off and the symbol  will go on - Fig. 7.3).

**Attention:** If the **AUTO** symbol is steady a cooking program has already been programmed, by pushing the button  you have cancelled of the program and the switched to manual.

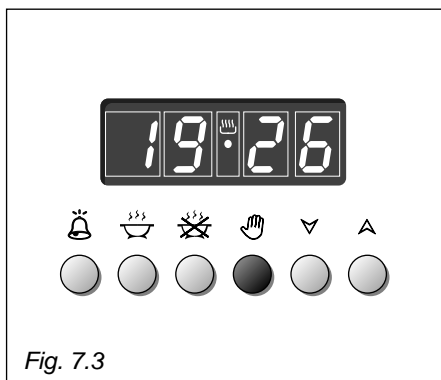

If the oven is switch on, you must switch off manually.





## ELECTRONIC TIMER

The timer program consists only of a buzzer which may be set for a maximum period of 23 hours and 59 minutes.

If the **AUTO** flashing push the  button.

To set the time, push the  button and the  or  until you obtain the desired time in the panel (fig. 7.4).

Having finished the setting, the clock hour will appear on the panel and the  symbol will be lighted.

The countdown will start immediately and may be seen at any moment on the panel by simply pressing the button .

At the end of the time, the  symbol will be switched off and an intermittent buzzer will go off; this can be stopped by pressing one of any of the buttons.

## SETTING THE FREQUENCY OF THE AUDIBLE SIGNAL

The selection from 3 possibilities of sound can be made by pressing the  button.

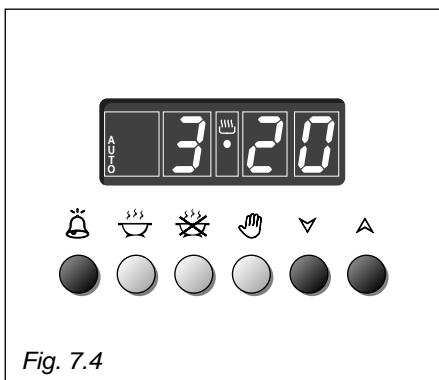









## AUTOMATIC OVEN COOKING

To cook food automatically in the oven, it is necessary to:

1. Set the length of the cooking time
2. Set the end of the cooking time
3. Set the temperature and the oven cooking program.

These operations are done in the following way:

1. Set the length of the cooking time by pushing the  button and the  button to advance, or  to go back if you have passed the desired time (fig. 7.5). The **AUTO** and the  symbol will be on.
2. Set the end of the cooking time by pressing the  button (the cooking time already added to the clock time will appear), and the  button (fig. 7.6); if you pass the desired time you may get back by pushing the  button.

After this setting, the  symbol will go off. If after this setting, the **AUTO** flash on the panel and a buzzer gives off, it means there was an error in the programming.

In this case, modify the end of cooking time or the cooking time itself by following again the above mentioned instructions.

3. Set the temperature and the cooking program by using the switch and thermostat knobs of the oven (see specific chapters).

Now the oven is programmed and everything will work automatically, that is the oven will turn on at the right moment to end the cooking at the established hour. During cooking, the  symbol remains on.

By pushing the  button you can see the time that remains until the end of cooking.

The cooking program may be cancelled in any moment by pushing .

At the end of the cooking time the oven will turn off automatically, the  symbol will turn off, **AUTO** will flash and a buzzer will sound, which can be turned off by pushing any of the buttons.

Turn the switch and thermostat knobs to zero and put the programmer onto “manual” by pressing the .

**Attention:** A power cut makes the clock go to zero and cancels the set programs.

After a power cut, three zeros will flash on the panel.

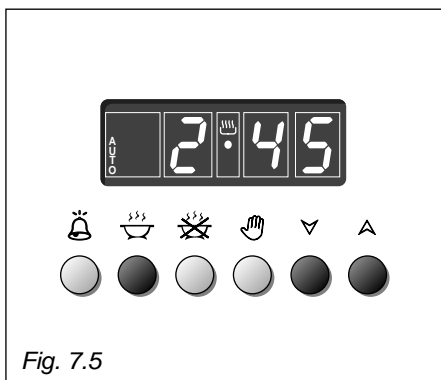

Fig. 7.5

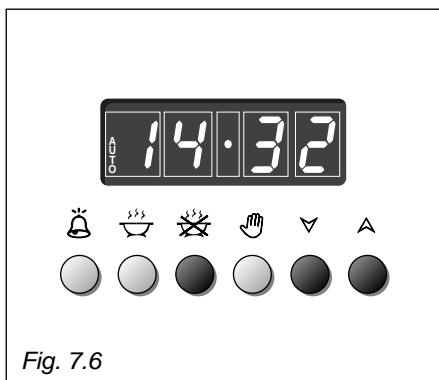





Fig. 7.6



## SEMI - AUTOMATIC COOKING

This function is only used to set the **END** of the cooking time of the oven. There are two ways of setting this function.

1. Set the length of the cooking time by pushing the  button and the 

button to advance, or  to go backwards (Fig. 7.7). This sets the desired "stop" time.



or

2. Set the end of the cooking time by pushing the  button and the 

button to advance, or  to go backwards if you have passed the desired time (Fig. 7.8).

**AUTO** and the  symbol will be on. Then set the temperature and the cooking program using the oven switch and thermostat knob (see relevant sections for details).

The oven is switched on and it will be switched off automatically at the end of the desired time.

During cooking, the  symbol remains on and by pressing the button  you can see the time that remains till the end of the cooking.

**The cooking time can be cancelled at any moment by pushing the  button.**

At the end of the cooking, the  symbol will turn off, the **AUTO** will flash and a buzzer will sound.

The buzzer can be cancelled by pressing any of the buttons.

Turn the switch and thermostat knobs to zero and reset the programmer back to "manual" by pressing the  button.

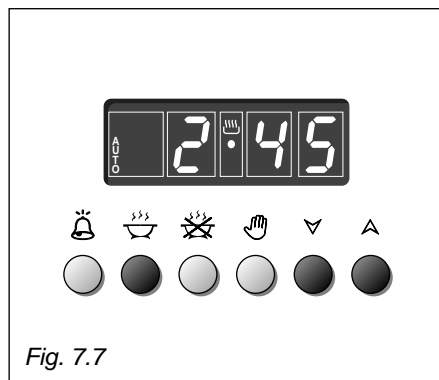

Fig. 7.7

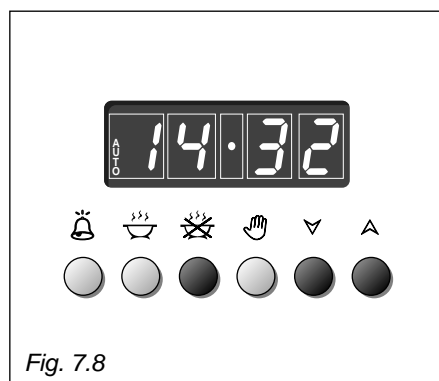

Fig. 7.8

# 8 - Cleaning and Maintenance

---

## **GENERAL ADVICE**

---

- When the appliance is not being used, it is advisable to keep the gas tap closed.
  - Every now and then check to make sure that the flexible tube that connects the gas line or the gas cylinder to the appliance is in perfect condition and eventually substitute it if it shows signs of wearing or damage.
  - The periodical lubrication of the gas taps must be done only by specialized personnel.
  - If a tap becomes stiff, do not force; contact your local Service Centre.
- **Important:**  
**Before any operation of cleaning and maintenance disconnect the appliance from the electrical network.**

### **Attention**

The appliance gets very hot, mainly around the cooking areas. It is very important that children are not left alone in the kitchen when you are cooking.

Do not use a steam cleaner because the moisture can get into the appliance thus make it unsafe.

## CLEANING

All the enamelled parts must be cleaned with a sponge and soapy water or other non-abrasive products.

Dry preferably with a soft cloth.

Acidic substances like lemon juice, tomato sauce, vinegar etc. can damage the enamel if left too long.

## STAINLESS STEEL SURFACES

The stainless steel front panels on this cooker (facia, oven door, drawer or storage compartment) are protected by a finger-print proof lacquer.

To avoid damaging this lacquer, do not clean the stainless steel with abrasive cleaners or abrasive cloths or scouring pads.

**ONLY SOAP/WARM WATER MUST BE USED TO CLEAN THE STAINLESS STEEL SURFACES.**

## OVEN DOOR AND DRAWER

The internal glass of the oven door can be easily removed for cleaning by unscrewing the two lateral fixing screws (fig. 8.2).

The drawer (fig. 8.3) comes out like a normal drawer.

**Attention: Do not store flammable material in the oven, or the accessory drawer.**

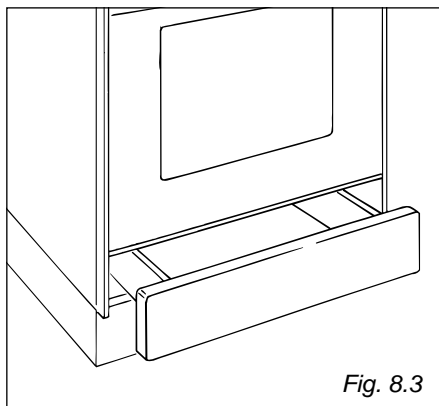
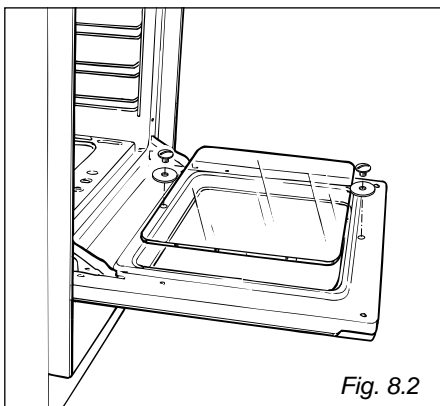

## INSIDE OF OVEN

This must be cleaned regularly. Remove and refit the side runner frames as described on the next chapter. With the oven warm, wipe the inside walls with a cloth soaked in very hot soapy water or another suitable product. Side runner frames, tray and rack can be removed and washed.

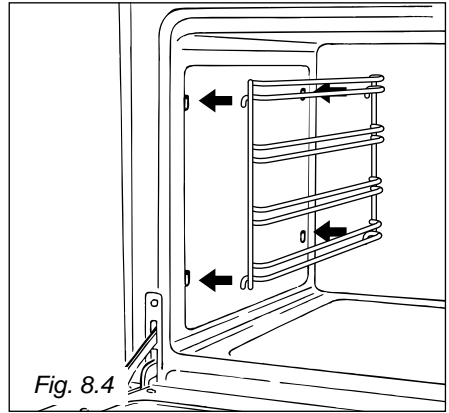





Fig. 8.4

## USING THE OVEN FOR THE FIRST TIME

- Slide in the wire racks on the oven wall as in Fig. 8.4.
- Position the shelf and tray as per Fig. 8.5.
- To eliminate possible traces of grease it is necessary to pre-heat the oven at the maximum temperature.
  - For 60 minutes in the  position, for 30 minutes in the  position and for another 15 minutes in the  position.

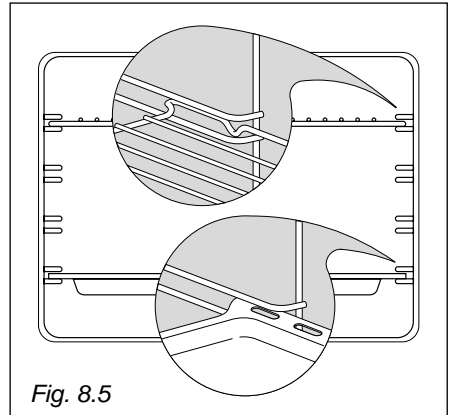

Fig. 8.5

## BURNERS

They can be removed and washed only with soapy water.  
Detergents can be used but must not be abrasive or corrosive.  
Do not use abrasive sponges or pads.  
Do not put in dishwasher.

After each cleaning, make sure that the burner-caps, as well as the burners, have been well wiped off and **CORRECTLY POSITIONED**.

It is essential to check the correct position of the burner-caps as the least displacement from the housing may cause serious problems.

**Special attention has to be paid in order not to exchange the housing of the two small burners shown in fig. 8.6. The burner caps can be interchangeable.**

It is absolutely necessary to check the perfect housing of the burner-ring as an incorrect housing may cause serious problems.

Check also that the electrodes for ignition are always clean in order to ensure a regular spark.

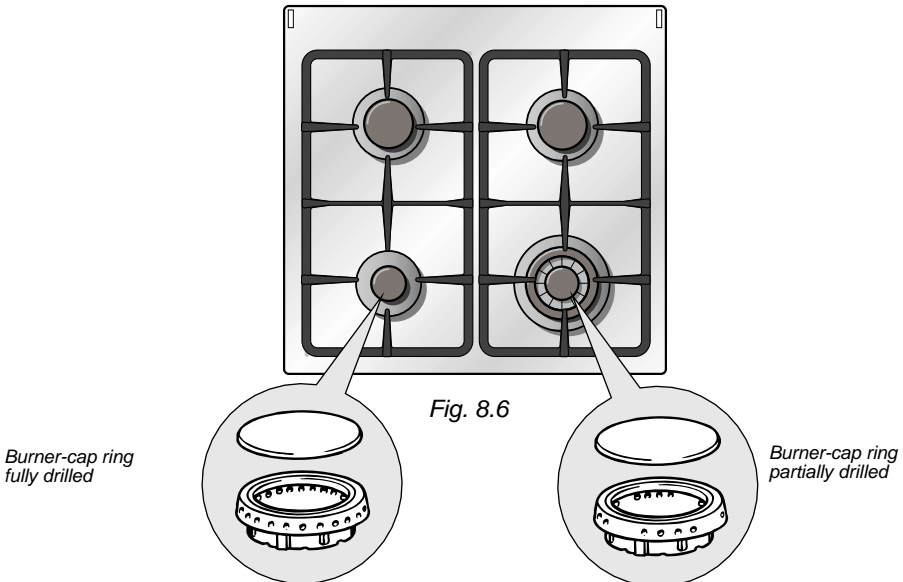

## REPLACING THE OVEN LIGHT BULB

**Switch the oven off at the mains.**

When the oven is cool unscrew and replace the bulb with another one resistant to high temperatures (300°C), voltage 230 V (50 Hz), 15 W, E14.

Note: Oven bulb replacement is not covered by your guarantee.

# Type A

## REMOVING THE OVEN DOOR

The oven door can easily be removed as follows:

- Open the door to the full extent (fig. 8.7A).
- Attach the retaining rings to the hooks on the left and right hinges (fig. 8.7B).
- Hold the door as shown in fig. 8.7.
- Gently close the door and withdraw the lower hinge pins from their location (fig. 8.7C).
- Withdraw the upper hinge pins from their location (fig. 8.7D).
- Rest the door on a soft surface.
- To replace the door, repeat the above steps in reverse order.

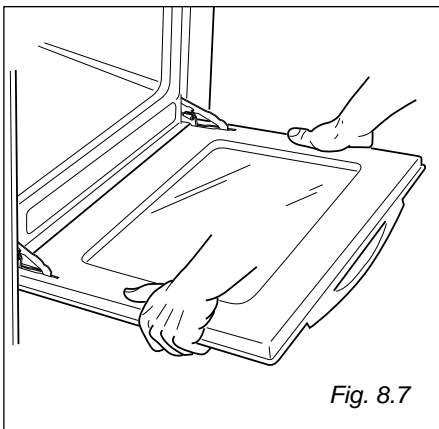
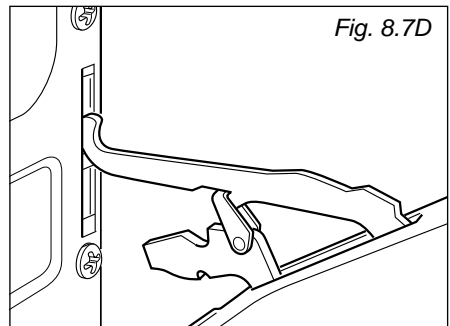
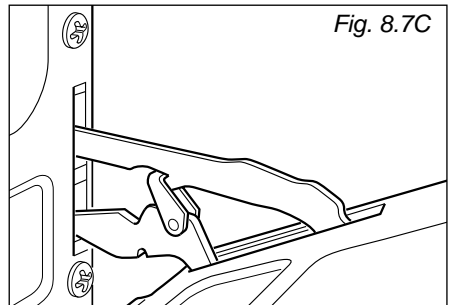
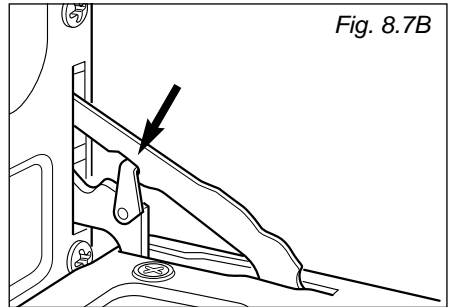
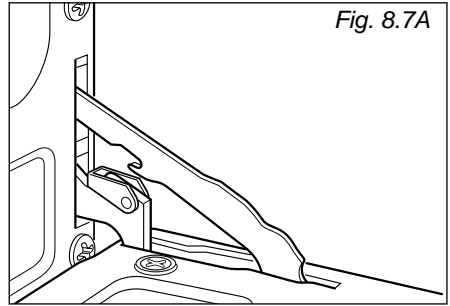

# Type B

## DISMANTLING THE DOOR

Please operate as follows:

- Open the door completely.
- Push down the lever “L” and, keeping it in this position, slowly close the door in order to block the hinge.
- Grip the door (as indicated in fig. 8.9) and, while closing it, release the two hinges as shown in fig. 8.10.

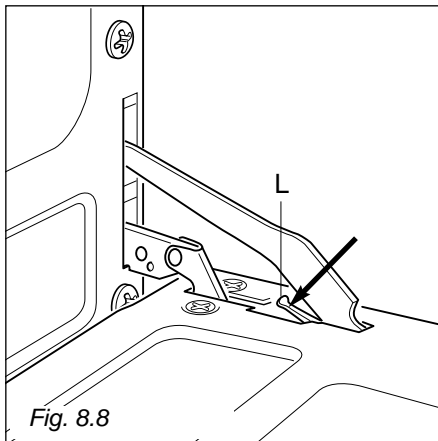

## DOOR ASSEMBLY

- Grip the door with your hands placed near the hinges and raise the levers “H” with your forefingers (fig. 8.10)
- Insert the hinges in their position until levers “H” are hooked.
- Open the door completely to obtain the release of levers “L”.

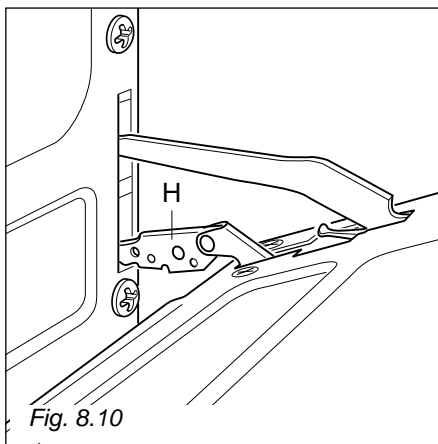
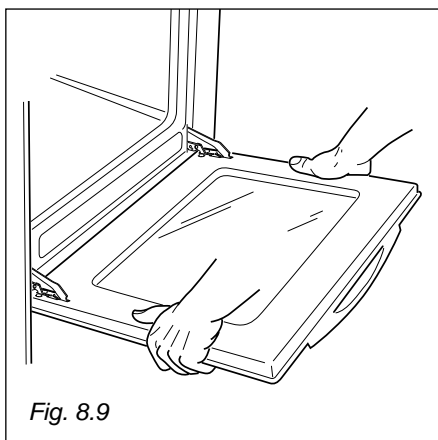

# Helpful Advice

---

## Trouble shooting

### Problem

Food too brown but not cooked.

### Remedy

Turn down the oven temperature slightly and cook a little longer

### Problem

Food cooked but not brown enough.

### Remedy

Increase temperature.

### Problem

Food baking unevenly.

### Remedy

1. The temperature may be slightly high turn it down
2. Position the food in the centre of the shelves rather than towards the sides of the oven.
3. Rotate the food a half turn in the oven.
4. Try pre-heating the oven for 5-15 minutes prior to baking.

Always remove cooked items as soon as they are ready and continue cooking the under-cooked items until they are completely finished.

## Changing the Oven Cavity Light Bulb.

### If the oven light falls:

1. Turn off the oven by switching the oven selector to 0, switch off at the cooker point.
2. When the oven is cool, reach back and upwards inside the oven, the bulb is in the top left corner.
3. Unscrew the light glass cover, replace the bulb with a new one of the same specification and screw the cover back until it is hand tight.

**NOTE: Oven bulb replacement is not covered by your guarantee.**

Other bulbs cannot be changed by yourself and should be replaced by an authorised CAPLE Service Engineer.

Bulbs other than the oven bulb are covered by the guarantee.

**IMPORTANT: Ovens get hot. Keep children away from this appliance at all times.**

## SAFETY PRECAUTIONS

**During use the oven door glass becomes hot.**

In the presence of children, in order to avoid contact with the hot door, a third internal glass should be mounted.

This third internal glass is supplied on request as an optional (not included in price).

Please contact your retailer or the After-Sales Service, indicating the model bought.

### If Your Oven Does Not Work

Before calling a CAPLE service engineer run through the following checklist.

1. The oven is connected to the power supply and that the fuse is intact.
2. Make sure the timer control is set to the manual position, and that the oven has not been set inadvertently for an automatic or timed programme.

If you are in any doubt about carrying out these checks, call the **CAPLE Helpline on 0870 241 1142.**

A charge will be made if the appliance is found to be in working order, or if it has not been installed in accordance with these instructions, or if it has been used incorrectly.

## **CAPLE "Built-in" Service**

Should you require service at any time, please contact the **Caple Helpline on 0870 241 1142**.

**Caple** have a nationwide service network of engineers who will respond quickly to your call.

Always replace spare parts with genuine **Caple** spares. These are available from authorised **Caple Service Centres** or by mail order from our **National Service Stores, simply telephone 0870 241 1142**.

When ordering parts always quote the model number and serial number of your appliance.

### **YOUR GUARANTEE**

CAPLE guarantees all parts of this product for one year from the date of purchase. During that time, should it become necessary CAPLE engineers will replace or repair all defective parts free of charge, except for parts subject to fair wear and tear, such as lightbulbs.

Parts and the engineers labour costs are chargeable after the first 12 months.

To qualify for benefits under the guarantee, you must be able to provide proof of date of purchase and the appliance must have been supplied, installed and used for domestic purposes only in accordance with CAPLE instructions.

Consequential losses and accidental damage to the product are not covered by the guarantee.

This guarantee does not affect your statutory or common law rights.

CAPLE cannot be responsible for the results of using this appliance for any other purposes other than those described in these instructions.