



Instruction manual for electric double oven

Model code: C3400



Contact Caple on 0844 800 3830 or for spare parts www.4caple.co.uk

Thank you for buying your new CAPLE Double Oven. To ensure that you get the best results from your new CAPLE oven, we strongly suggest that you read this instruction manual thoroughly before use. This manual contains installation advice, cleaning tips and a cooking guide, as well as other important facts about your CAPLE oven. If treated with care, your CAPLE oven should give you years of trouble-free cooking.

For Product Service or Spare Parts
please check contact details at:
www.caple.co.uk

DECLARATION OF CE CONFORMITY

- This double oven has been designed to be used only for cooking. Any other use (such as heating a room) is improper and dangerous.
- This double oven has been designed, constructed, and marketed in compliance with:
 - safety requirements of EU Directive “Low voltage” 2006/95/EC
 - safety requirements of EU Directive “EMC” 2004/108/EC;
 - requirements of EU Directive 93/68/EEC.



BEFORE USING FOR THE FIRST TIME

- Read the instructions carefully before installing and using the appliance.
- After unpacking the appliance, check that it is not damaged. In case of doubt, do not use the appliance and contact your supplier or a qualified engineer.
- Remove all the packing materials (i.e. plastic bags, polystyrene foam, etc.) and do not leave it around within easy reach of children, as these may cause serious injuries. The packaging materials are recyclable.
- Do not attempt to modify the technical characteristics of the appliance, as it may become dangerous to use.
- The appliance should be installed and all the electrical connections made by a qualified engineer in compliance with local regulations in force and following the manufacturer's instructions.

IMPORTANT PRECAUTIONS AND RECOMMENDATIONS FOR USE OF ELECTRICAL APPLIANCES

Use of any electrical appliance implies the necessity to follow a series of fundamental rules. In particular:

- never touch the appliance with wet hands or feet;
- do not operate the appliance barefooted;
- do not allow children or disabled people to use the appliance without your supervision.

The manufacturer cannot be held responsible for any damages caused by improper, incorrect or unreasonable use of the appliance.

Important information for correct disposal of the product in accordance with ec directive 2002/96/EC.

At the end of its working life, the product must not be disposed of as urban waste. It must be taken to a special local authority differentiated waste collection centre or to a dealer providing this service.

Disposing of a household appliance separately avoids possible negative consequences for the environment and health deriving from inappropriate disposal and enables the constituent materials to be recovered to obtain significant savings in energy and resources. As a reminder of the need to dispose of household appliances separately, the product is marked with a crossed-out wheeled dustbin.

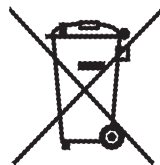

Important precautions and recommendations

- Do not carry out any cleaning or maintenance without first disconnecting the appliance from the electrical supply.
- During and after use of the double oven, certain parts will become very hot. Do not touch hot parts.
- After use always ensure that the control knobs are in the **OFF** position (“O” or “●”).
- Keep children away from the double oven during use.
- Household appliances are not intended to be played with by children.
- Children, or persons with a disability which limits their ability to use the appliance, should have a responsible person to instruct them in its use. The instructor should be satisfied that they can use the appliance without danger to themselves or their surroundings.

- **WARNING**

When correctly installed, your product meets all safety requirements laid down for this type of product category. However special care should be taken around the rear or the underneath of the appliance as these areas are not designed or intended to be touched and may contain sharp or rough edges, that may cause injury.

- **Fire Risk!** Do not store inflammable materials inside the ovens.
- Always use oven gloves when removing the shelves and food trays from the oven whilst hot.
- Do not line the oven walls with aluminium foil. Do not place baking trays or the drip tray on the base of the oven chamber.
- Clean the ovens regularly and do not allow fat or oils to build up in the oven base or trays. Remove spillages as soon as they occur.
- Always stand back from the oven when opening the oven door to allow steam and hot air to escape before removing the food.
- Do not hang towels, dishcloths or other items on the oven or its handles – as this could be a fire hazard.
- Make sure that electrical cords connecting other appliances in the proximity cannot become entrapped in the oven doors.
- Before disposing of an unwanted appliance, it is recommended that it is made inoperative and that all potentially hazardous parts are made harmless.
- **Important:** This appliance has been designed for domestic use only. The appliance is **NOT** suitable for use within a semi-commercial, commercial or communal environment.
- **Safe food handling:** leave food in the oven for as short a time as possible before and after cooking. This is to avoid contamination by organisms which may cause food poisoning. Take particular care during warmer weather.
- Do not operate your appliance by means of an external timer or separate remote-control system.

USING THE DOUBLE OVEN FOR THE FIRST TIME

You are advised to carry out the following operations:

- Assemble the interior of the oven as described under the heading “Cleaning and maintenance”
- Switch the empty oven ON at maximum temperature for about two hours to eliminate traces of grease and smell from the components.
- Let the oven cool down, switch off the electrical supply, then clean the inside of the oven with a cloth soaked in water and neutral detergent and dry thoroughly.

USING THE PRESS-AND-TURN CONTROL KNOBS

The control knobs are flush-mounted in the control panel.

Use them as follows:

- a. Press lightly on the knob (figure A);
- b. The knob will extend outwards as illustrated in figure B.
- c. Turn the knob to the required position (figure C).
- d. When you have finished cooking, turn the knob back to the **OFF** position (“O” or “●”) and press it (figure D) so that it stays flush with the control panel again (figure F).

IMPORTANT:

Never press down the knob when it is not in the OFF position (figure E).

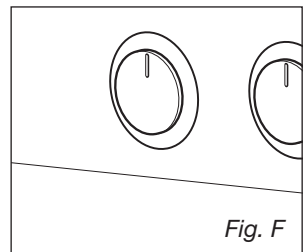
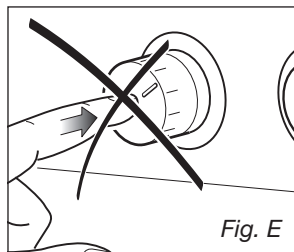
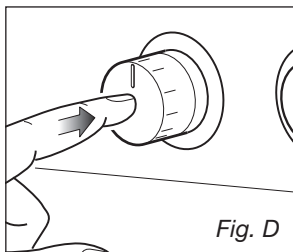
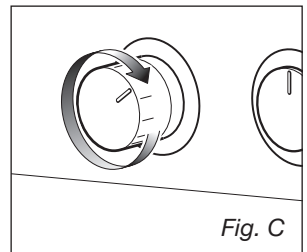
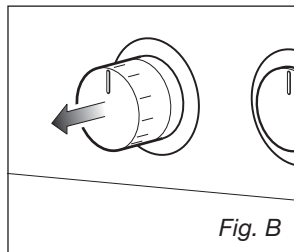
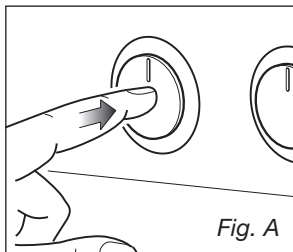

1 - Electrical Requirements

WARNING!
ELECTRICITY CAN BE EXTREMELY DANGEROUS.
THIS APPLIANCE MUST BE EARTHED.

For your safety please read the following information:

- The connection to the electrical network must be carried out by qualified personnel and must be according to existing norms.
- The appliance must be connected to the electrical network verifying above all that the voltage corresponds to the value indicated on the specifications plate and that the cables section of the electrical plant can bear the load which is also indicated on the plate.
- The appliance can be connected directly to the mains placing an omnipolar switch with minimum opening between the contacts of 3 mm between the appliance and the mains.
- The power supply cable must not touch the hot parts and must be positioned so that it does not exceed 75°C at any point.
- Once the appliance has been installed, the switch must always be accessible.
- If the power supply cable is damaged it must be substituted by a suitable cable.

Before effecting any intervention on the electrical parts the appliance must be disconnected from the network.

IMPORTANT: this double oven must be connected to a suitable double pole control unit adjacent to the oven.

NO DIVERSITY CAN BE APPLIED TO THIS CONTROL UNIT.

FEEDER CABLE SECTION

Type H05RR-F or H05VV-F

230 V ~ 3 x 2,5 mm² (**)

(**) – Connection to wall-mounting distribution panel.

The connection of the appliance to the grounding unit is mandatory.
The manufacturer declines every responsibility for any inconvenience resulting from the inobservance of this condition.

CONNECTING THE DOUBLE OVEN MAINS CABLE

IMPORTANT: This oven must be connected to the mains power supply only by a suitably qualified person.

- Unscrew the screw A securing the cover plate B behind the oven (fig. 1.1).
- Remove the cover plate B.
- Remove the screws C from the cable clamp (fig. 1.2).
- Insert the mains cable (type H05RR-F or H05VV-F - 3x2,5 mm² section) into the cable protector P.
- Connect the phase and earth cables to the mains terminal connection block D.

	EARTH
	NEUTRAL
	LIVE

- Refit the cable clamp so that it clamps the outer sleeving of the cable, and screw the screws C.
- Refit the cover plate B and fix it with the screw A.

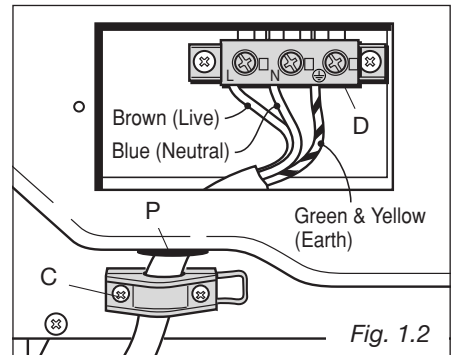
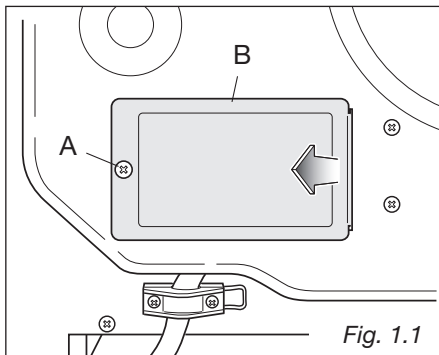

WARNING: This appliance must be earthed

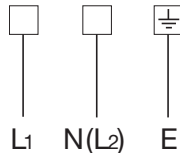

If the supply cord is damaged, it must be replaced by a qualified technician in order to avoid a hazard.

FOR THE INSTALLER

IMPORTANT

**The appliance shall be installed by a QUALIFIED INSTALLATION TECHNICIAN.
The appliance must be installed in compliance with regulations in force.**

The double oven is designed to fit into a cabinet of 600 mm width.

The double oven can be built in the kitchen units, but you must ensure that it is properly ventilated.

Lift the appliance into position onto the shelf, taking care NOT to lift it by the door handles.

If you open the oven doors, you will see some screw holes.

The oven should then be secured to the housing by fitting screws into these holes.

Remember the housing should not be free standing but be secured to the wall and/or adjacent fittings.

WARNING

- We would point out that the adhesive which bonds the plastic laminate to the furniture must withstand temperatures not less than 150° C to avoid delamination.
- **The appliance must be housed in heat resistant units.**
- **The walls of the units must be capable of resisting temperatures of 75 °C above room temperature.**
- **Taking care NOT to lift the oven by the door handles.**

WARNING

When correctly installed, your product meets all safety requirements laid down for this type of product category.

However special care should be taken around the rear or the underneath of the appliance as these areas are not designed or intended to be touched and may contain sharp or rough edges, that may cause injury.

2 - Location

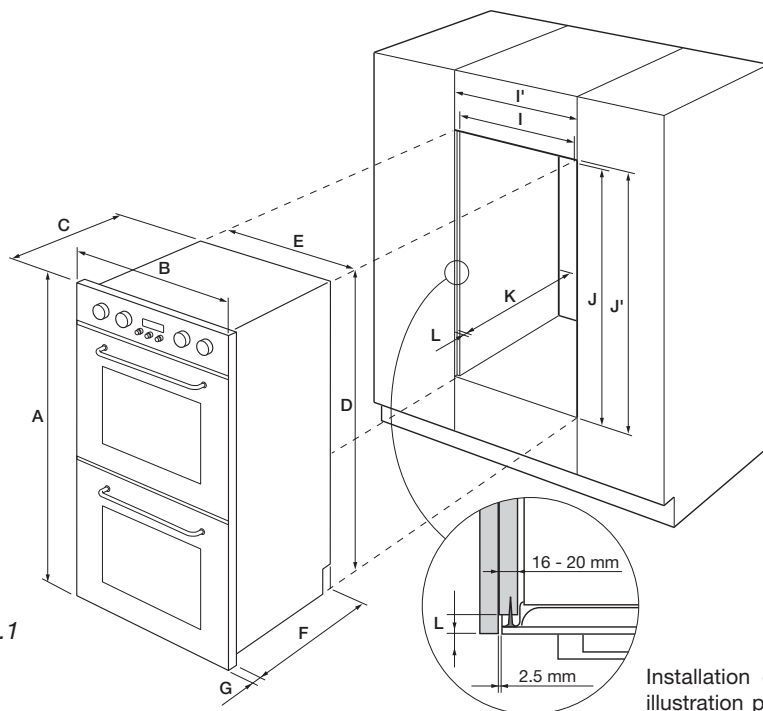

Fig. 2.1

Installation diagrams for illustration purposes only

Product and cabinetry dimensions (mm)

A	overall height* of product	1077
B	overall width of product	595
C	overall depth of product (excluding handle and knobs)	567
D	height of chassis	1057
E	width of chassis	556
F	depth of chassis	545
G	depth of oven frame and control panel (=distance between front of chassis and front of oven door, excl. knobs)	22
I	minimum inside width of cavity	560
I'	overall width of cavity	600
J	inside height of cavity	1065
J'	overall height of cavity	1082
K	minimum inside depth of cavity	550
L	flush fitting cabinetry clearance	22

* All height measurements include mounted feet.

FIXING THE OVEN

Introduce the oven into the furniture opening and fix it with screws (not supplied) as figure 2.2. It is essential that the oven rests on a surface which will support its weight, as the screw fixing is only complementary.

Note

It is essential that when installing your oven adequate air circulation is allowed for within the installation.

Inadequate air circulation may greatly impair the performance of your oven and may effect adjacent cabinets due to an increase in temperature.

Caution

Do not lift this oven by the door handles.

Adjust the hinges of furniture doors adjacent to the oven to allow a 4-5 mm gap between the furniture door and the oven frame.

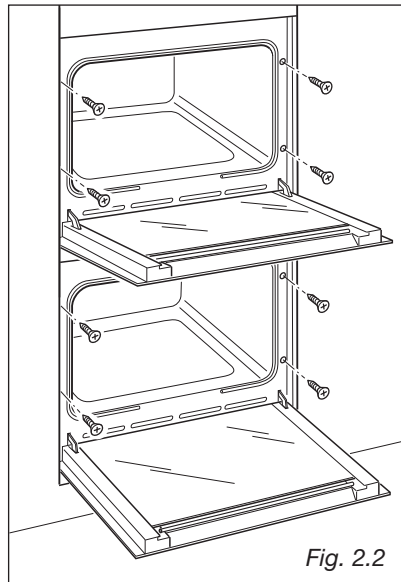

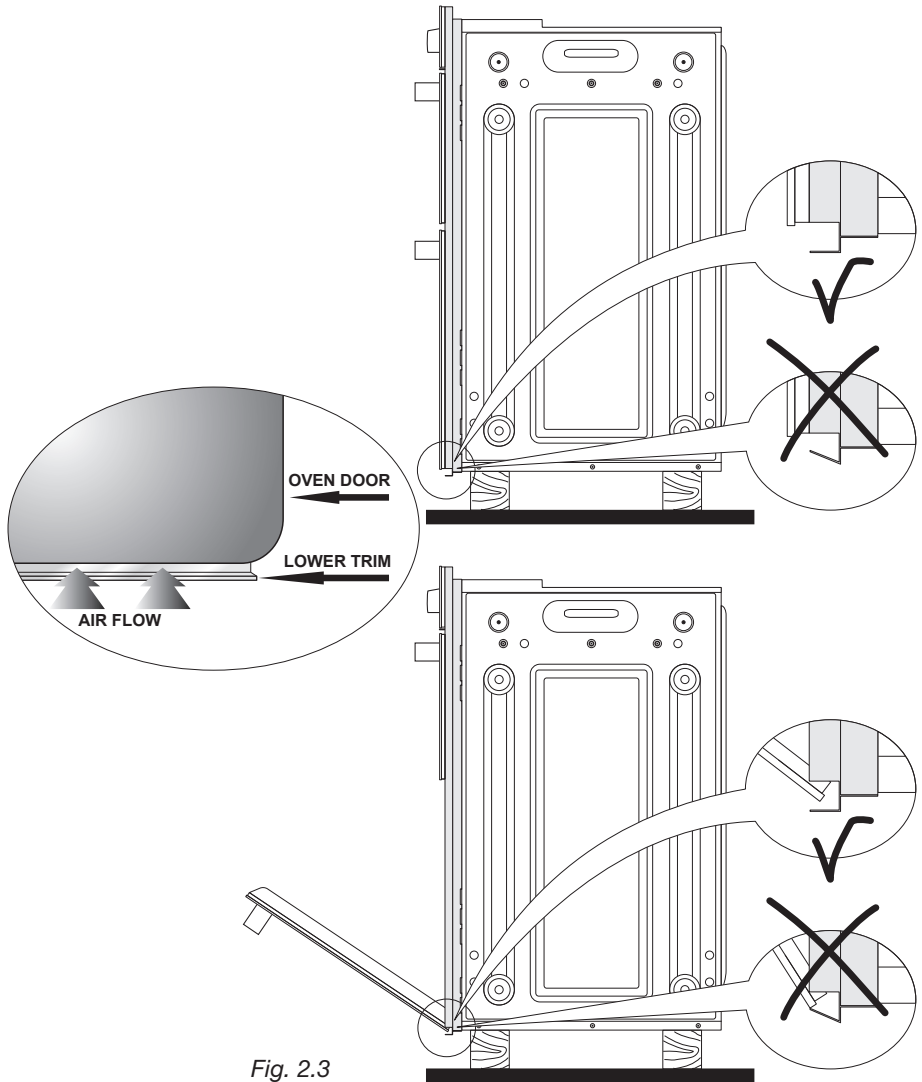

Fig. 2.3

IMPORTANT:

To avoid damage to the lower trim please note the following instructions.

The lower trim is designed to allow for good air circulation and the correct opening of the oven door.

To ensure the trim is not damaged due to the appliance being placed on the floor, the appliance should be suitably supported as in above illustrations.

After installation the appliance door should be slowly opened to ensure no damage has occurred.

No responsibility for lower trim damage will be accepted if these instructions have not been followed.

3 - Control panel

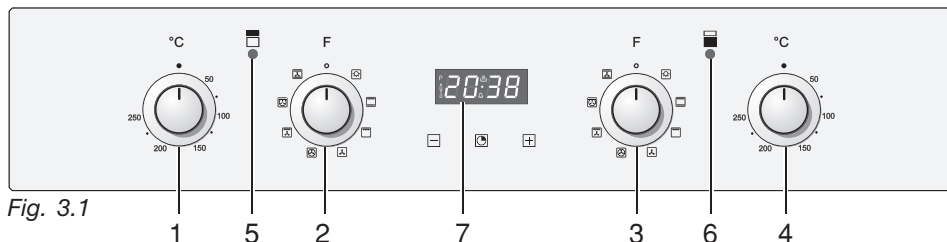

Fig. 3.1

CONTROL PANELS DESCRIPTION

1. Oven temperature knob (Top oven)
2. Oven function selector knob (Top oven)
3. Oven function selector knob (Bottom oven)
4. Oven temperature knob (Bottom oven)
5. Top oven temperature indicator light
6. Bottom oven temperature indicator light
7. Clock and timer with “Touch-Control” keys (Top oven only)

NOTE: Your appliance has been fitted with a cooling fan to achieve optimum efficiency of the controls and to ensure lower surface temperatures are maintained.

The cooling fan motor switches ON/OFF depending on temperature.

Depending on cooking temperatures and times, the cooling fan may run on even after appliance oven has been switched off. The duration of this time is dependent on previous cooking temperature and duration.

4 - Multifunction Top & Bottom Ovens

Attention: The oven door becomes very hot during operation. Keep children away.



GENERAL FEATURES

The multifunction oven can be programmed for 7 different functions to satisfy every cooking need.

The 7 positions are thermostatically controlled and are obtained by a combination of 4 heating elements which are:

- Lower element 1300 W
- Upper element 1000 W
- Grill element 2000 W
- Circular element 2200 W

NOTE:

Before using for the first time, it is advisable to operate the oven at the maximum temperature for 60 minutes in the position  and  to eliminate possible traces of grease on the heating elements. Repeat the operation for another 15 minutes with the grill element on as explained in the GRILLING and USE OF THE GRILL section.

WARNING:

The door is hot, use the handle.

During use the appliance becomes hot. Care should be taken to avoid touching heating elements inside the oven.

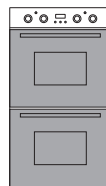

OPERATING PRINCIPLES

Heating and cooking in the MULTIFUNCTION oven are obtained in the following ways:

a. by normal convection

The heat is produced by the upper and lower heating elements.

b. by forced convection

A fan sucks in the air contained in the oven, which circulates it through the circular heating element and then forced back into the oven by the fan. Before the hot air is sucked back again by the fan to repeat the described cycle, it envelops the food in the oven, provoking a complete and rapid cooking. It is possible to cook several dishes simultaneously.

c. by semi-forced convection

The heat produced by the upper and lower heating elements is distributed throughout the oven by the fan.

d. by radiation

The heat is radiated by the infra red grill element.

e. by radiation and ventilation

The radiated heat from the infra red grill element is distributed throughout the oven by the fan.

f. by ventilation

The food is defrosted by using the fan only function without heat.

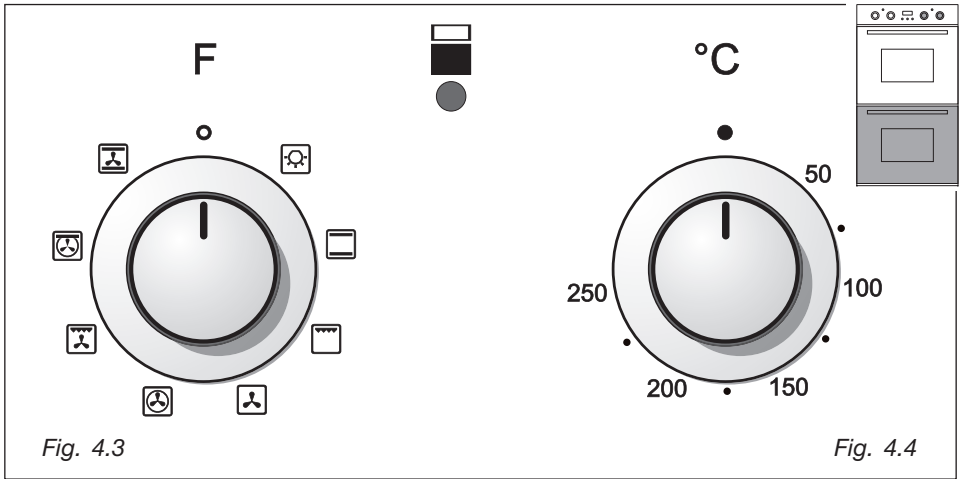
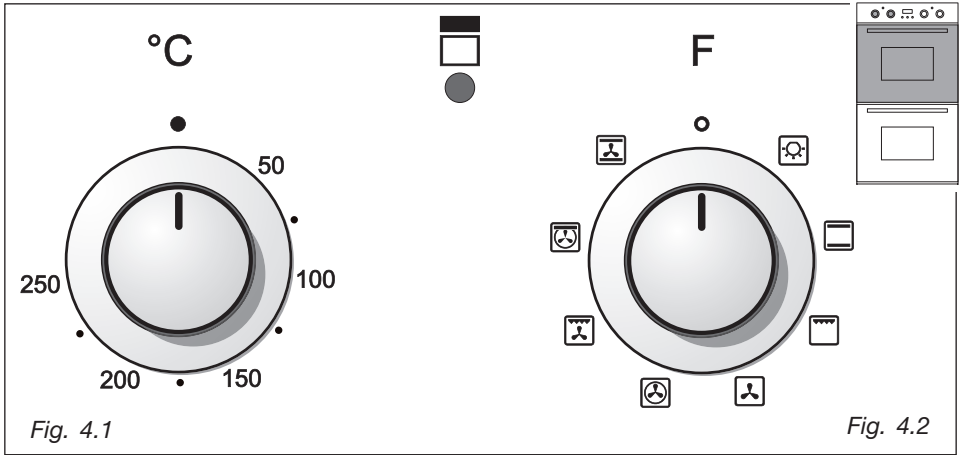

THERMOSTAT KNOB (figs. 4.1 - 4.4)

To turn on the heating elements of the oven, set function selector knob to the required position and the thermostat knob to the desired temperature. The elements will turn on or off automatically which is determined by the thermostat. The operation of the heating elements is signalled by a light placed on the control panel.

FUNCTION SELECTOR KNOB (fig. 4.2 - 4.3)

Rotate the knob clockwise to set the oven to one of the following functions:



OVEN LIGHT

By turning the function selector knob to this setting, the oven light will illuminate in the oven cavity.

The oven light will operate on all selected functions.



TRADITIONAL CONVECTION COOKING

The upper and lower heating elements are switched on.

The heat is diffused by natural convection and the temperature must be regulated between 50°C and the maximum position with the thermostat knob.

It is necessary to preheat the oven before introducing the foods to be cooked.

Recommended for:

For foods which require the same cooking temperature both internally and externally, i. e. roasts, spare ribs, meringue, etc.



GRILLING

The infra-red heating element is switched on. The heat is diffused by radiation.

Use with the oven door **closed** and the thermostat knob must be regulated between **50°C** and **225°C maximum**.

For correct use see chapter "USE OF THE GRILL".

Recommended for:

Intense grilling action for cooking with the broiler; browning, crisping, "au gratin", toasting, etc.



DEFROSTING FROZEN FOODS

Only the oven fan is on.

To be used with the thermostat knob in the off "●" position because the other positions have no effect.

The defrosting is done by simple ventilation without heat.

Recommended for:

To rapidly defrost frozen foods; 1 kilogram requires about one hour.

The defrosting times vary according to the quantity and type of foods to be defrosted. 15



HOT AIR COOKING

The circular element and the fan are on.

The heat is diffused by forced convection and the temperature must be regulated between 50°C and the maximum position with the thermostat knob.

It is not necessary to preheat the oven.

Recommended for:

For foods that must be well done on the outside and tender or rare on the inside, i. e. lasagna, lamb, roast beef, whole fish, etc.



VENTILATED GRILL COOKING

The infra-red grill and the fan are on.

The heat is mainly diffused by radiation and the fan then distributes it throughout the oven.

The temperature must be regulated between **50°C and 225°C maximum** with the thermostat knob. It is necessary to preheat the oven for about 5 minutes.

For correct use see chapter "GRILLING AND AU GRATIN".

Always grill with the oven door closed.

Recommended for:

For grill cooking when a fast outside browning is necessary to keep the juices in, i. e. veal steak, steak, hamburger, etc.



MAINTAINING TEMPERATURE COOKING OR SLOWLY HEATING FOODS

The upper element and the circular element connected in series, are switched on; also the fan is on. The heat is diffused by forced convection with the most part being produced by the upper element.

The temperature must be regulated between 50° and 140 °C with the thermostat knob.

Recommended for:

To keep foods hot after cooking.

To slowly heat already cooked foods.



CONVECTION COOKING WITH VENTILATION

The upper and lower heating elements and the fan turn on.

The heat coming from the top and bottom is diffused by forced convection.

The temperature must be regulated between 50°C and the maximum position with the thermostat knob.

Recommended for:

For foods of large volume and quantity which require the same internal and external degree of cooking; for ex: rolled roasts, turkey, legs, cakes, etc.

Cooking Advice

STERILIZATION

Sterilization of foods to be conserved, in full and hermetically sealed jars, is done in the following way:

- a. Set the switch to position 
- b. Set the thermostat knob to position 175 °C and preheat the oven.
- c. Fill the dripping pan with hot water.
- d. Set the jars onto the dripping pan making sure they do not touch each other and the door and set the thermostat knob to position 125 °C.

When sterilization has begun, that is, when the contents of the jars start to bubble, turn off the oven and let cool.

REGENERATION

Set the switch to position  and the thermostat knob to position 150° C. Bread becomes fragrant again if wet with a few drops of water and put into the oven for about 10 minutes.

ROASTING

To obtain classical roasting, it is necessary to remember:

- that it is advisable to maintain a temperature between 180 and 200 °C.
- that the cooking time depends on the quantity and the type of foods.

COOKING DIFFERENT DISHES AT THE SAME TIME

With the function selector in position , the ventilated oven allows you to cook different types of food at the same time.

Fish, cakes and meat can be cooked together without the smells and flavours mixing. The only precautions required are the following:

- The cooking temperatures must be as close as possible with a maximum difference of 20° - 25°C between the different foods.
- Different dishes must be placed in the oven at different times according to the cooking time required for each one. This type of cooking obviously provides a considerable saving on time and energy.

GRILLING AND “AU GRATIN”

Grilling may be done by selecting grill+fan setting  with the function selector knob, because the hot air completely envelops the food that is to be cooked.

Set the thermostat knob **between 50°C and 225°C maximum** and after having pre-heated the oven, simply place the food on the grid.

Close the door and let the oven operate until grilling is done.

Adding a few dabs of butter before the end of the cooking time gives the golden “au gratin” effect.

Grilling with the oven door closed.

It is recommended that you do not grill for longer than 30 minutes at any one time.

Attention: the oven door becomes very hot during operation.

Keep children away.

USE OF THE GRILL

Set the function selector knob to position  and the thermostat knob **between 50°C and 225°C maximum**.

Leave to warm up for approximately 5 minutes with the door **closed**.

Introduce the food to be cooked, positioning the rack as close to the grill as possible.

The dripping pan should be placed under the rack to catch the cooking juices and fats.

Always grill with the oven door closed.

Grilling with the oven door closed and not for longer than 30 minutes at any one time.

Attention: the oven door becomes very hot during operation.

Keep children away.

OVEN COOKING

Before introducing the food, preheat the oven to the desired temperature.

For a correct preheating operation, it is advisable to remove the tray from the oven and introduce it together with the food, when the oven has reached the desired temperature.

Check the cooking time and turn off the oven 5 minutes before the theoretical time to recuperate the stored heat.

Recommended cooking temperature

Food	°C	°F	Gas Mark	Shelf Position*	Cooking Time (approx)
CAKES					
Victoria sandwich	190	375	5	2 or 3	20-25 mins
Small cakes/buns	190	375	5	1 and 2	15-20 mins
Maidera cake	180	350	4	2 or 3	20 mins
Fruit cake	170	325	3	3	1 ³ / ₄ hours
Rich fruit cake	150	300	2	3 or 4	2 ¹ / ₂ hours
Scones	225	425	8-9	2	8-10 mins
PASTRY					
Puff	225	425	8-9	2	10-20 mins
Short crust	200	400	6	2	20-30 mins
Plate tarts	200-210	400-410	6	1 or 2	30-35 mins
Quiches and flans	200-210	400-410	6	1 or 2	40-45 mins
YEAST					
Bread loaf	225	425	7-8	2	35-55 mins
Bread rolls	220	425	7	1 or 2	15-20 mins
Pizza dough	230	450	8	2	20 mins
ROAST MEAT					
Beef – Medium	190	375	5	2 or 3	20 mins/lb + 20 mins
Lamb	190	375	5	2 or 3	25-30 mins/b + 25 mins
Pork	190-200	375-400	5-7	2 or 3	30 mins/lb + 30 mins
Veal	190	375	5	2 or 3	30 mins/b + 30 mins
Chicken	190	375	5	2 or 3	30 mins/b + 30 mins
Turkey up to 10lb	180	350	4	2 or 3	18-20 mins/b + 20 mins
Stews/casseroles	150-170	300-325	2-3	2 or 3	1 ¹ / ₂ 2 hours

N.B. For fan ovens reduce the temperature by 10-20°C. For any dish taking one hour or over to cook, reduce the cooking time by 10 minutes per hour.

* Shelf positions have been counted from the top of the oven to the base. A fan oven creates more even temperature throughout, therefore the shelf positions are not as critical.

5 - Clock and Timer with “Touch Control” Keys

Top oven only

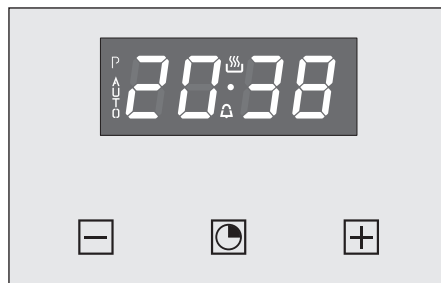
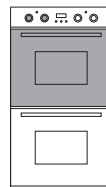

Fig. 5.1

Keys:	
and	<p>Touched simultaneously (for more than 2 seconds):</p> <ul style="list-style-type: none"> • setting the clock; • setting the timer volume (by touching once, along with the “” key); • to cancel automatic cooking at any time.
	<p>Function selection (touched for more than 2 seconds):</p> <ul style="list-style-type: none"> • setting the clock (only after first connection or after a power failure); • timer; • automatic cooking “dur” (duration) - how long the food will take to cook (by touching the “” key again); • automatic cooking “End” - the time you would like the oven turns off (by touching the “” key two more times);
	Increases the number shown on the display
	Decreases the number shown on the display



Illuminated symbols:		
AUTO	<i>flashing</i>	Automatic cooking completed, oven in automatic position but not set
AUTO	<i>steady illumination</i>	Oven set for automatic cooking, cooking still not taking place
	<i>flashing</i>	Timer being set
	<i>steady illumination</i>	Timer in operation
	<i>steady illumination</i>	Oven set for manual cooking
and AUTO	<i>AUTO flashing</i>	Automatic cooking being set
and AUTO	<i>steady illumination</i>	Oven set for automatic cooking, cooking taking place

“TOUCH-CONTROL” KEYS

The “touch-control” keys shall be operated by the fingers (just by touching the key). When using touch controls it is best to use the ball of your finger rather than the tip.



The keys are automatically deactivated:

- 8 seconds after the last selection; the deactivation is indicated by an acoustic signal (“beep”).





To reactivate just touch the “” key or the “” and “” keys (simultaneously) for more than 2 seconds./

SETTING THE CLOCK

When first connected, or after a power failure, the digits and “” will shown on the display.

To set the clock, touch the “” key, for more than 2 seconds, and then the “” or “” keys.

Important: the oven does not operate, in manual cooking, without first having set the clock.

To set the clock, with the appliance already connected, touch the “” and “” keys simultaneously (for more than 2 seconds), then “” or “” keys.

Important:







- **changing the time will delete any automatic program;**
- **after setting the clock, the oven starts to operate in the selected function (manual cooking). The “” symbol is steady illuminated.**





USING THE TIMER

You can use the timer at any time, even when the oven is not in use.

The timer does not turn the oven off.

The timer can be set for up to 23 hours and 59 minutes.

- To set the timer, touch the “” key for more than 2 seconds (the “” symbol flashes), than the “” or “” keys.
- After about 8 seconds an acoustic signal (“beep”) will sound confirming the regulation (“” symbol steady illuminated).
- To check the remaining time touch the “” key for more than 2 seconds. If the remaining time is more than a minute the display will show hours and minutes; if less than a minute the display will show seconds.
- When the time is up, the timer will beep.

Touch the “” key , for more then 2 seconds, to turn it off; or press the “” or “” key to stop the beep and than the “” key, for more than 2 seconds, to deactivate the “” symbol flashing on the display.

- Turn off the oven manually (function and thermostat knobs in the off position) if the manual cooking has been completed.

SETTING THE TIMER VOLUME

You can select from three volume levels.

- Touch the “+” and “-” keys simultaneously for more than 2 seconds.
- Touch the “🔊” key; you can read on the display the current timer volume (“ton1”, “ton2” or “ton3”).
- Touch the “-” key to listen or change the timer volume.
- Timer volume activated: the last displayed.
- After about 8 seconds an acoustic signal (“beep”) will sound confirming the volume setting; then the time of day will be displayed.

AUTOMATIC COOKING

Use automatic cooking to automatically turn the oven on, cook, and then turn the oven off.

1. Check the clock shows the correct time.
2. Select the function and temperature (function and temperature knobs). The oven will come on.
3. Decide how long the food will take to cook, allowing time for preheating if necessary.
4. Touch the “🔊” key for more than 2 seconds and then touch again. “dur” will show (duration). Using the “+” and “-” keys, set the cooking time.
5. Decide the time you would like the oven to turn off; touch the “🔊” key for more than 2 seconds and then touch it two times again. “End” will show. Using the “+” and “-” keys, set the cooking time.

Note: while “dur” is displayed you can change to “End” just by touching one time the “🔊” key (within 8 seconds from the last selection).

If there is time to wait before cooking starts, the current time of day and “AUTO” will show in the clock display. The oven will switch off but is now set for automatic cooking.

If you are already at home to turn the oven on and only want the oven to turn off automatically, start cooking as normal, then follow step 4 or step 5 to set a time to stop the oven.

When automatic cooking starts, “🔊” will be displayed and the oven will turn on.

- To see the remaining cook time, follow step 4 up to display “dur” (duration).
- To see the set stop time, follow step 5 up to display “End”.
- To cancel automatic cooking at any time, touch the “+” and “-” keys simultaneously (for more than 2 seconds) and turn the temperature and function knobs to the off position.

When the stop time is reached, the oven will turn off, the timer will beep and “AUTO” will flash:

- Touch any key to stop the beeping.
- Touch the “🔊” key, for more than 2 seconds, to return the oven to the manual mode (“🔊” symbol steady illuminated on the display).
- Turn the temperature and function knobs to the off position.

Attention: after a power failure any automatic program is deleted. Turn off the oven manually.

6 - Cleaning and Maintenance

GENERAL ADVICE

Important:

Before any operation of cleaning and maintenance disconnect the appliance from the electrical supply.

It is advisable to clean when the appliance is cold and especially for cleaning the enamelled parts.

Avoid leaving alkaline or acidic substances (lemon juice, vinegar, etc.) on the surfaces. Avoid using cleaning products with a chlorine or acidic base.

WARNING

When correctly installed, your product meets all safety requirements laid down for this type of product category. However special care should be taken around the rear or the underneath of the appliance as these areas are not designed or intended to be touched and may contain sharp or rough edges, that may cause injury.

INSIDE OF OVEN

The oven should always be cleaned after use when it has cooled down.

The cavity should be cleaned using a mild detergent solution and warm water.

Suitable proprietary chemical cleaners may be used after first consulting with the manufacturers recommendations and testing a small sample of the oven cavity.

Abrasive cleaning agents or scouring pads/cloths should not be used on the cavity surface.

NOTE: The manufacturers of this appliance will accept no responsibility for damage caused by chemical or abrasive cleaning.

Let the oven cool down and pay special attention no to touch the hot heating elements inside the oven cavity.

ENAMELLED PARTS

All the enamelled parts must be cleaned with a sponge and soapy water only or other non-abrasive products.

Dry preferably with a microfibre or soft cloth.

Do not use a steam cleaner because the moisture can get into the appliance thus make it unsafe.

Do not store flammable material in the ovens.

Do not use harsh abrasive cleaners or sharp metal scrapers to clean the oven door glass since they can scratch the surface, which may result in shattering of the glass.

STAINLESS STEEL SURFACES, ALUMINIUM PARTS AND PAINTED OR SILK-SCREEN PRINTED SURFACES

Clean using an appropriate product. Always dry thoroughly.

IMPORTANT: these parts must be cleaned very carefully to avoid scratching and abrasion. You are advised to use a soft cloth and neutral soap.

GLASS CONTROL PANEL

Clean using an appropriate product.

Always dry thoroughly.

Do not use harsh abrasive cleaners or sharp metal scrapers to clean the control panel since they can scratch the surface, which may result in shattering of the glass.

OVEN FITTING OUT

- Assemble the wire racks to the oven walls using the 2 screws (Fig. 6.1).
- Slide in, on the guides, the shelf and the tray (fig. 6.2).
The shelf must be fitted so that the safety catch, which stops it sliding out, faces the inside of the oven.
- To dismantle, operate in reverse order.

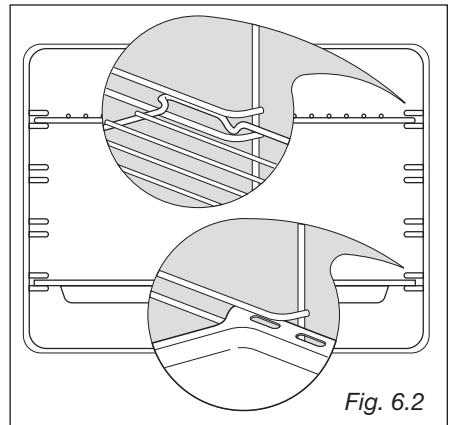
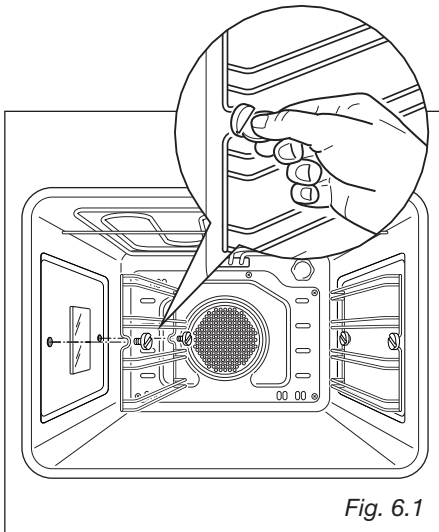

TELESCOPIC SLIDING SHELF SUPPORTS

The telescopic sliding shelf supports make it safer and easier to insert and remove the oven shelves and trays. They stop when they are pulled out to the maximum position.

Important! When fitting the sliding shelf supports, make sure that you fit:

- The slides to the top wire of a rack. They do not fit on the lower wire.
- The slides so that they run out towards the oven door.
- Both sides of each pair of shelf slides.
- Both sides on the same level.

To fix the sliding shelf support onto the side racks:

- Screw the side racks onto the oven wall (Fig. 6.1).
- Fit the sliding shelf support onto the top wire of a rack and press (Fig. 6.3). You will hear a click as the safety locks clip over the wire.

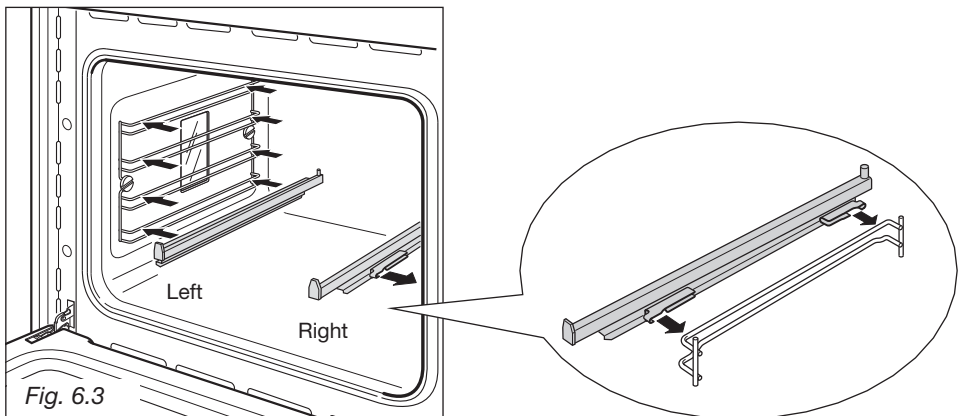

To remove the telescopic sliding shelf supports:

- Remove the side racks by unscrewing the fixing screws (Fig. 6.4).
- Lay down the telescopic sliding shelf support and side racks, with the telescopic sliding shelf support underneath.
- Find the safety locks. These are the tabs that clip over the wire of the side rack (arrow 1 in Fig. 6.5).
- Pull the safety locks away from the wire to release the wire (arrow 2 in Fig. 6.5).

Cleaning the sliding shelf supports

- Wipe the supports with a damp cloth and a mild detergent only.
- Do not wash them in the dishwasher, immerse them in soapy water, or use oven cleaner on them.

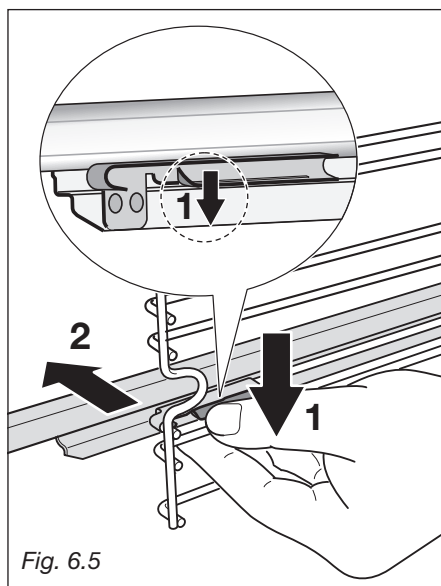
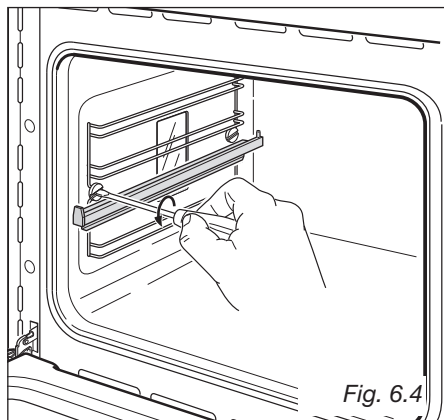

REPLACING THE OVEN LAMPS

WARNING: Ensure the appliance is switched off before replacing the lamp to avoid the possibility of electric shock.

- Let the oven cavity and the heating elements to cool down;
- Switch off the electrical supply;

REAR LAMP:

- Remove the protective cover **C** (fig. 6.6);
- Unscrew and replace the bulb **B** with a new one suitable for high temperatures (300°C) having the following specifications: 220-240V, E14 and same power (check watt power as stamped in the bulb itself) of the replaced bulb.
- Refit the protective cover;

LEFT LAMP:

- Remove the left wire rack by unscrewing the fixing screws.
- Press down from the top the protective cover **A** (fig. 6.6) and remove it by rotating on the lower side. **IMPORTANT:** never use screwdrivers or other utensils to remove the cover **A**. This could damage the enamel of the oven or the lampholder. Operate only by hands.
- Unscrew and replace the bulb **B** with a new one suitable for high temperatures (300°C) having the following specifications: 220-240V, E14 and same power (check watt power as stamped in the bulb itself) of the replaced bulb.
- Refit the protective cover **A** operating in reverse order. **ATTENTION:** the notch in the inner edge of the cover must be oriented toward the lamp.
- Assemble the left wire rack.

Note: Oven bulb replacement is not covered by your guarantee.

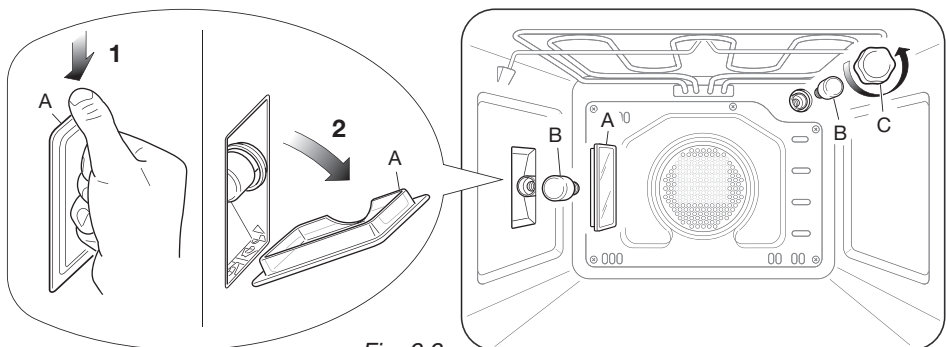
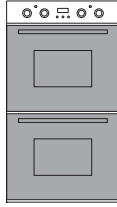

Fig. 6.6

REMOVING THE OVEN DOORS



The oven doors can easily be removed as follows:

- Open the door to the full extent (fig. 6.7a).
- Open the lever **A** completely on the left and right hinges (fig. 6.7b).
- Hold the door as shown in fig. 6.7.
- Gently close the door (fig. 6.7c) until left and right hinge levers **A** are hooked to part **B** of the door (fig. 6.7b).
- Withdraw the hinge hooks from their location following arrow **C** (fig. 6.7d).
- Rest the door on a soft surface.
- To replace the door, repeat the above steps in reverse order.

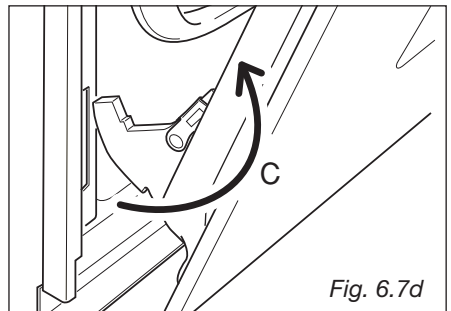
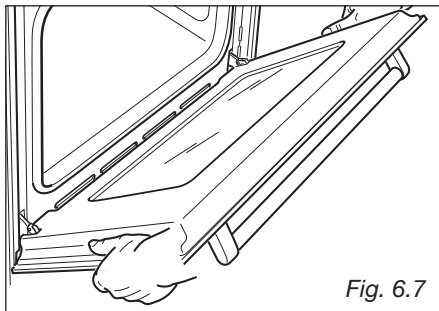
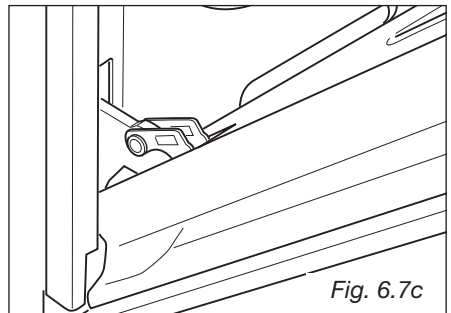
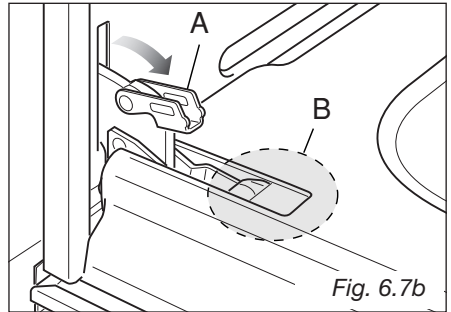
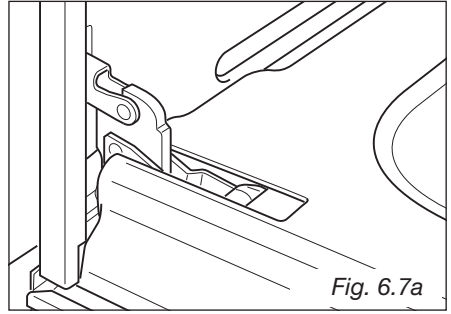

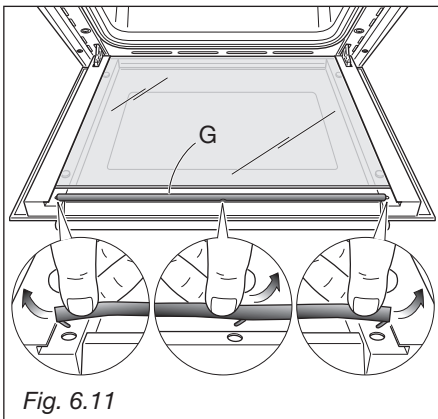
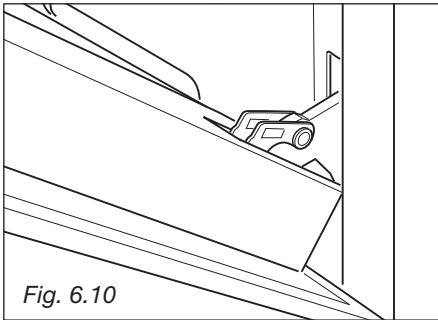
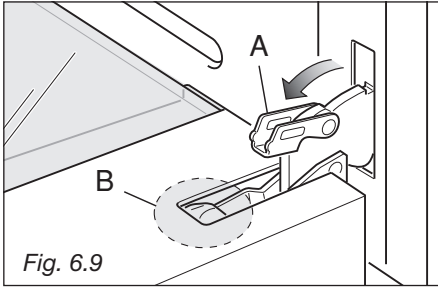
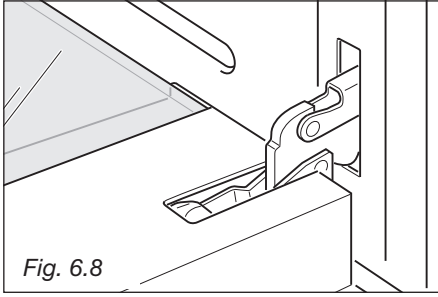

MODELS WITH REMOVABLE INNER PANE OF GLASS

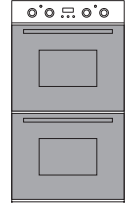

REMOVING THE INNER PANE

To clean the inner pane of the oven doors on both sides operate as follows:

- Open the door to the full extent (fig. 6.8).
- Open the lever **A** completely on the left and right hinges (fig. 6.9).
- Gently close the door (fig. 6.10) until left and right hinge levers **A** are hooked to part **B** of the door (fig. 6.9).
- **Top oven door only:** Remove the seal **G** by unhooking the no. 3 fixing hooks (fig. 6.11).
- Gently pull out the inner pane of glass (fig. 6.12).
- Clean the glass with an appropriate cleaner. Dry thoroughly, and place on a soft surface.
- Now you can also clean the inside of the outer glass.

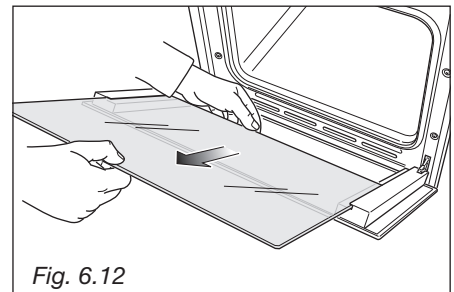

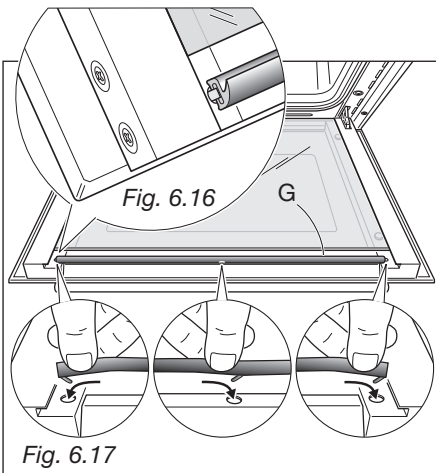
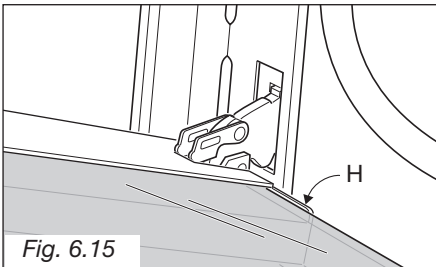
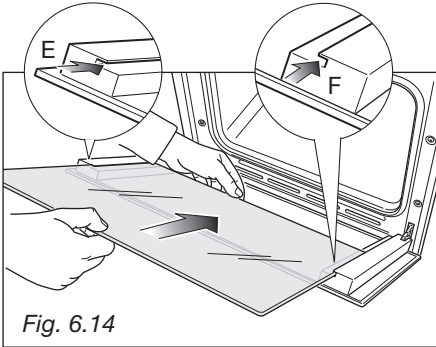
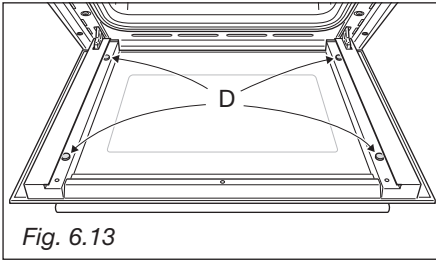

REASSEMBLING THE INNER PANE

To reassemble the inner pane of the oven doors operate as follows:

- Make sure the door is locked open (see fig. 6.10).
- Check the correct positioning of the no. 4 (four) silicon rubbers **D** (fig. 6.13).
- Check that you are holding the pane the correct way. You should be able to read the wording on it as it faces you.
- Insert the inner pane in the left **E** and right **F** side guides (fig. 6.14) and gently let it slide up to the retainers **H** (fig. 6.15).
- Top oven door only: Reassemble the seal **G** in the correct way (fig. 6.16) by hooking the no. 3 fixing hooks in the proper holes (fig. 6.17).
- Open completely the oven door and close the lever **A** on the left and right hinges (fig. 6.18).

IMPORTANT NOTE: pay attention not to exchange the inner panes of the top and bottom door. The inner pane of the top door is smaller than the inner pane of the bottom door.

The top oven door has a sealed gasket in the top part.

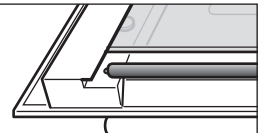

It is normal the opened gap between the top edge of the inner pane and the sealed gasket. This allows the cooling air circulation.

The bottom oven door has not a sealed gasket in the top part.

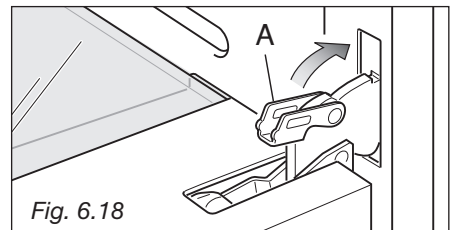
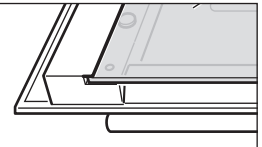

Helpful Advice

Trouble shooting

Problem

Food too brown but not cooked.

Remedy

Turn down the oven temperature slightly and cook a little longer.

Problem

Food cooked but not brown enough.

Remedy

Increase temperature.

Problem

Food baking unevenly.

Remedy

1. The temperature may be slightly high turn it down.
2. Position the food in the centre of the shelves rather than towards the sides of the oven.
3. Rotate the food a half turn in the oven.
4. Try pre-heating the oven for 5-15 minutes prior to baking.

Always remove cooked items as soon as they are ready and continue cooking the under-cooked items until they are completely finished.

Changing the Oven Cavity Light Bulb.

If the oven light falls:

1. Before carrying out any work on the electrical parts of the appliance, the appliance must first be disconnected from the electrical supply.
2. When the oven is cool, replace the bulb operating as indicated at page no.27.

NOTE: Oven bulb replacement is not covered by your guarantee.

Other bulbs cannot be changed by yourself and should be replaced by an authorised CAPLE Service Engineer. Bulbs other than the oven bulb are covered by the guarantee.

IMPORTANT: Oven gets hot. Keep children away from this appliance at all times.

If you are in any doubt about carrying out these checks, call the **CAPLE Helpline**.

Please check contact details at **www.caple.co.uk**.

A charge will be made if the appliance is found to be in working order, or if it has not been installed in accordance with these instructions, or if it has been used incorrectly.

CAPLE “Built-in” Service

Should you require service at any time, please contact the **Caple Helpline**. Please check contact details at **www.caple.co.uk**.

Caple have a nationwide service network of engineers who will respond quickly to your call.

Always replace spare parts with genuine **Caple** spares. These are available from authorised **Caple Service Centres** or by mail order (please check contact details at **www.caple.co.uk**).

When ordering parts always quote the model number and serial number of your appliance.

YOUR GUARANTEE

CAPLE guarantees all parts of this product for one year from the date of purchase. During that time, should it become necessary CAPLE engineers will replace or repair all defective parts free of charge, except for parts subject to fair wear and tear, such as lightbulbs.

Parts and the engineers labour costs are chargeable after the first 12 months.

To qualify for benefits under the guarantee, you must be able to provide proof of date of purchase and the appliance must have been supplied, installed and used for domestic purposes only in accordance with CAPLE instructions.

Consequential losses and accidental damage to the product are not covered by the guarantee.

This guarantee does not affect your statutory or common law rights.

CAPLE cannot be responsible for the results of using this appliance for any other purposes other than those described in these instructions.

