



C308SS

**Caple Double Multi Function Oven
Stainless Steel**



TECHNICAL INFORMATION

C 308 SS

FUM0CP006X

tav. 1

cat. 18.F2926

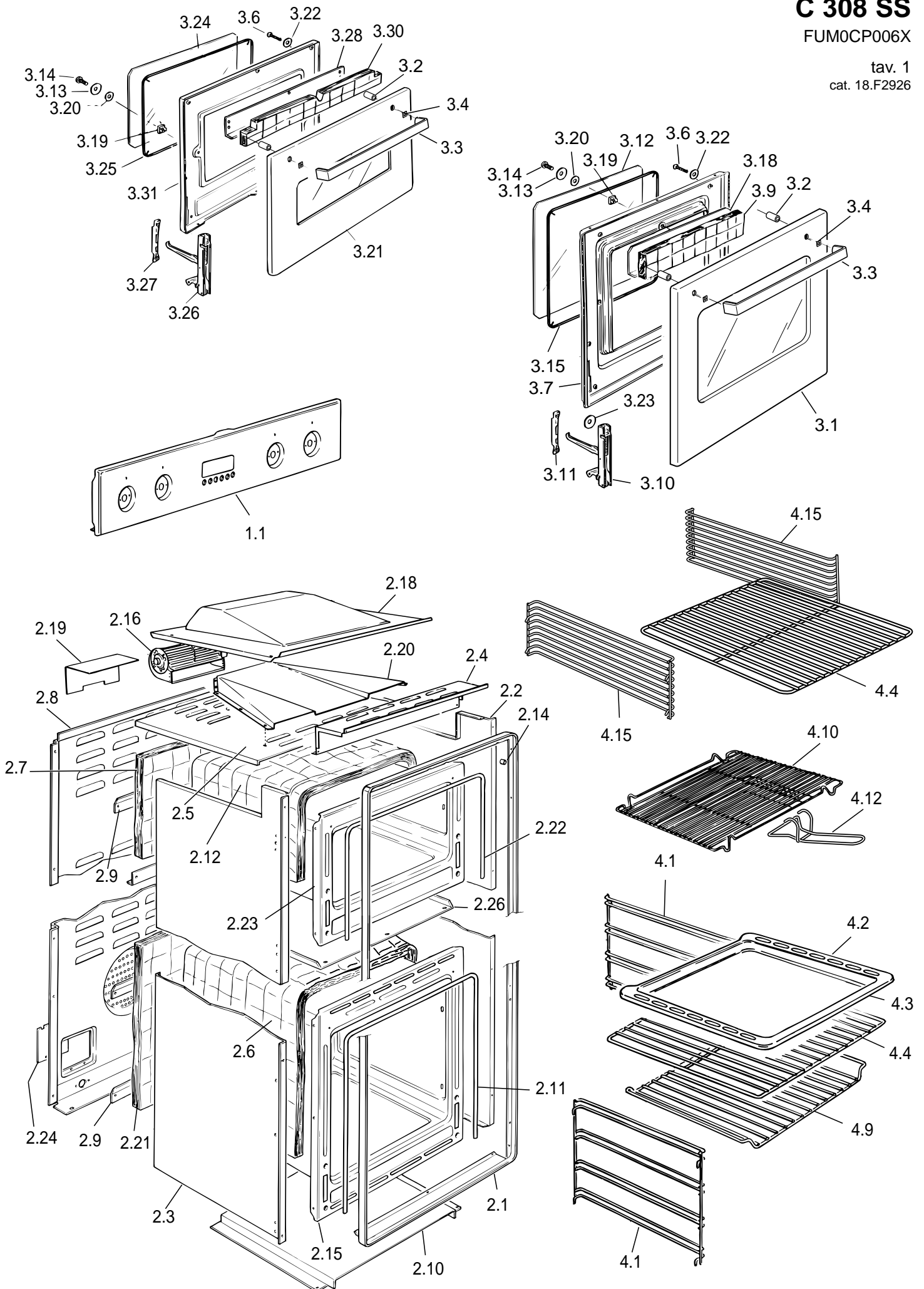

REF.	CODE	DESCRIPTION
1.1	35F741SYCP	Control panel
2.1	083225067	Trim surround
2.2	411UM02	Right side panel
2.3	411UM03	Left side panel
2.4	411FG03	Control panel shelter
2.5	421FG01Z	Upper shelter
2.6	030092.1	Bottom oven insulation
2.7	030065	Top oven rear insulation
2.8	411UM01.1	Rear panel
2.9	4216003Z	Insulation cross-piece
2.10	411F706	Bottom panel
2.11	053039	Bottom oven seal
2.12	030066.1	Top oven insulation
2.14	085019	Spacer
2.15	450UM1EM11	Bottom oven cube
2.16	079017	Tangential fan 220/240
2.18	411FG07	Upper shelter
2.19	411F715	Upper air conveyor
2.20	411F716	Air conveyor
2.21	030045	Bottom oven rear insulation
2.22	053052	Top oven seal
2.23	450UM1ES14	Top oven cube
2.24	51BUM01	Shield
2.26	411UM04	Shelter
3.1	032F71016F	Outer glass
3.2	085084	Sleeve
3.3	037228061	Handle
3.4	103734080	Plaque
3.6	001030	Screw
3.7	373FF715K	Bottom oven door skin
3.9	030057	Bottom oven door insulation
3.10	063103	Bottom oven hinge (male)
3.11	063025	Bottom oven hinge (female)
3.12	0311000.1T	Bottom oven inner glass
3.13	103205	Inner glass washer
3.14	001214	Screw
3.15	053084	Bottom oven glass seal
3.18	411F729	Bottom oven insulation support
3.19	214021	Nut with clips
3.20	003035	Silicone washer
3.21	032UM1614V	Top oven outer glass
3.22	003041	Washer
3.24	0311086.1T	Top oven inner glass
3.25	053086	Top oven glass seal
3.26	063065	Top oven hinge (male)
3.27	063066	Top oven hinge (female)
3.28	411UM05	Top oven insulation support
3.30	030064	Top oven door insulation
3.31	373FUM04K	Top oven door skin
4.1	217291	Shelf support
4.2	48B6101K	Oven tray
4.4	217270.1	Wire shelf
4.9	217271	Wire shelf
4.10	217397	Grill-pan grid
4.12	037144	Grill-pan grid handle
4.15	217503	Shelf support

C 308 SS

FUM0CP006X

tav. 2
cat. 18.F2926

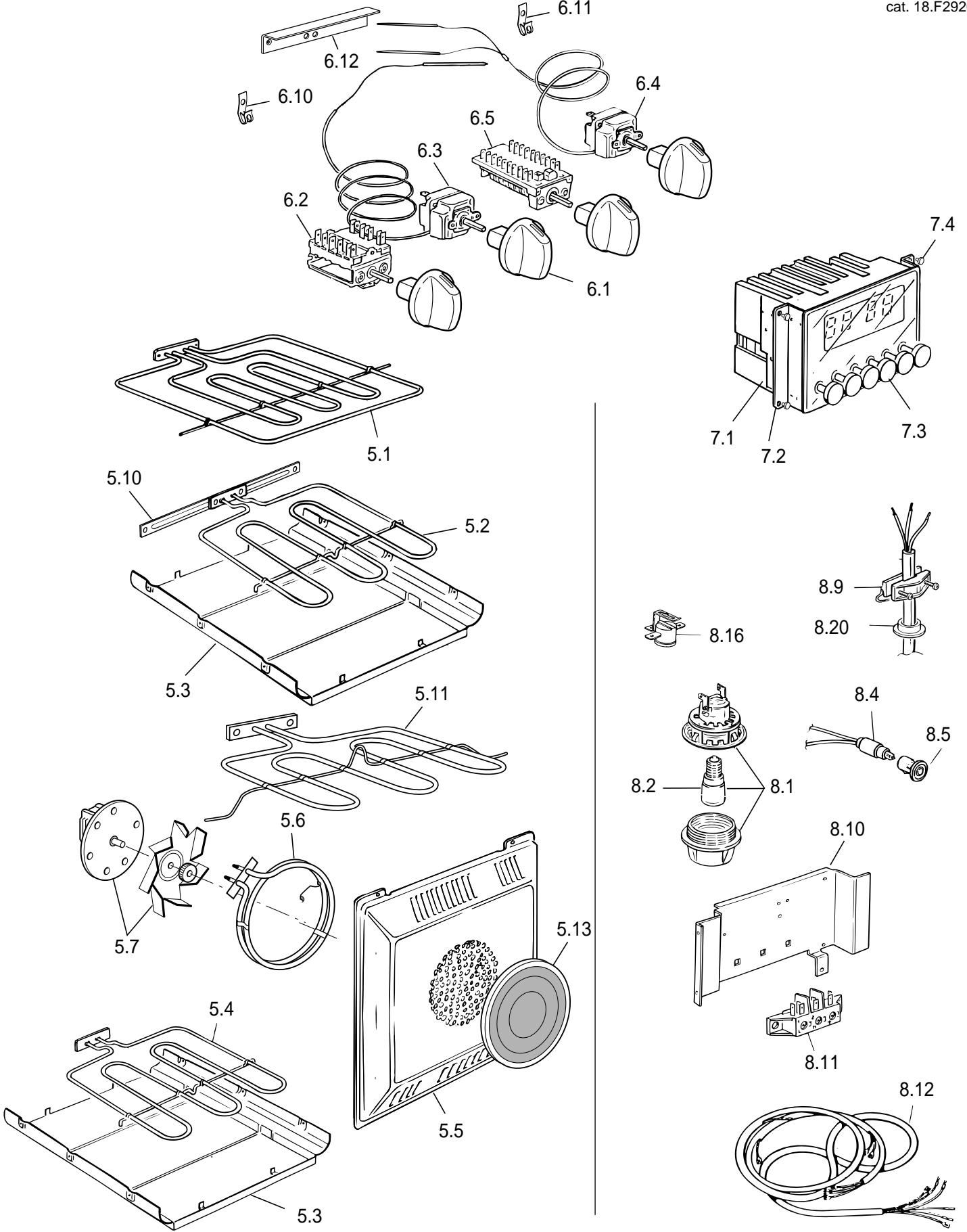

REF.	CODE	DESCRIPTION
5.1	062072004	Top grill element - 230 V
5.2	062058004A	Top oven bottom element - 230 V
5.3	421F701Z	Element shelter
5.4	062058004	Bottom element - 230 V
5.5	47AN601K	Fan diffuser
5.6	062057004	Fan element - 230 V
5.7	079008001F	Fan motor - 220/240 V
5.10	094207	Bottom element fixing bar
5.11	062079004	Grill element - 230 V
5.13	103085	Filter
6.1	218G00X332	Control knob
6.2	050040.1	Switch
6.3	066072	Thermostat
6.4	066078	Thermostat
6.5	050028	Switch
6.10	213023	Clip
6.11	213025	Clip
6.12	094289	Bulb thermostat protection
7.1	074041	Electronic programmer
7.2	094120	Electronic programmer chassis
7.3	103271080	Button
7.4	040011	Rubber
8.1	072004	Lamp holder
8.2	073013001	Lamp
8.4	073038.2	Control lamp L=200
8.5	0730135	Control lamp cover (Red)
8.9	052008	Wire fastener
8.10	094162	Terminal bracket
8.11	051038	Terminal block
8.12	1131350	Wiring
8.16	066057	Cut-off thermostat 140°
=	066073	Cut-off thermostat 150°
=	066080	Cut-off thermostat 55°
8.20	052007	Anti-shock
-	1102115	Instruction booklet

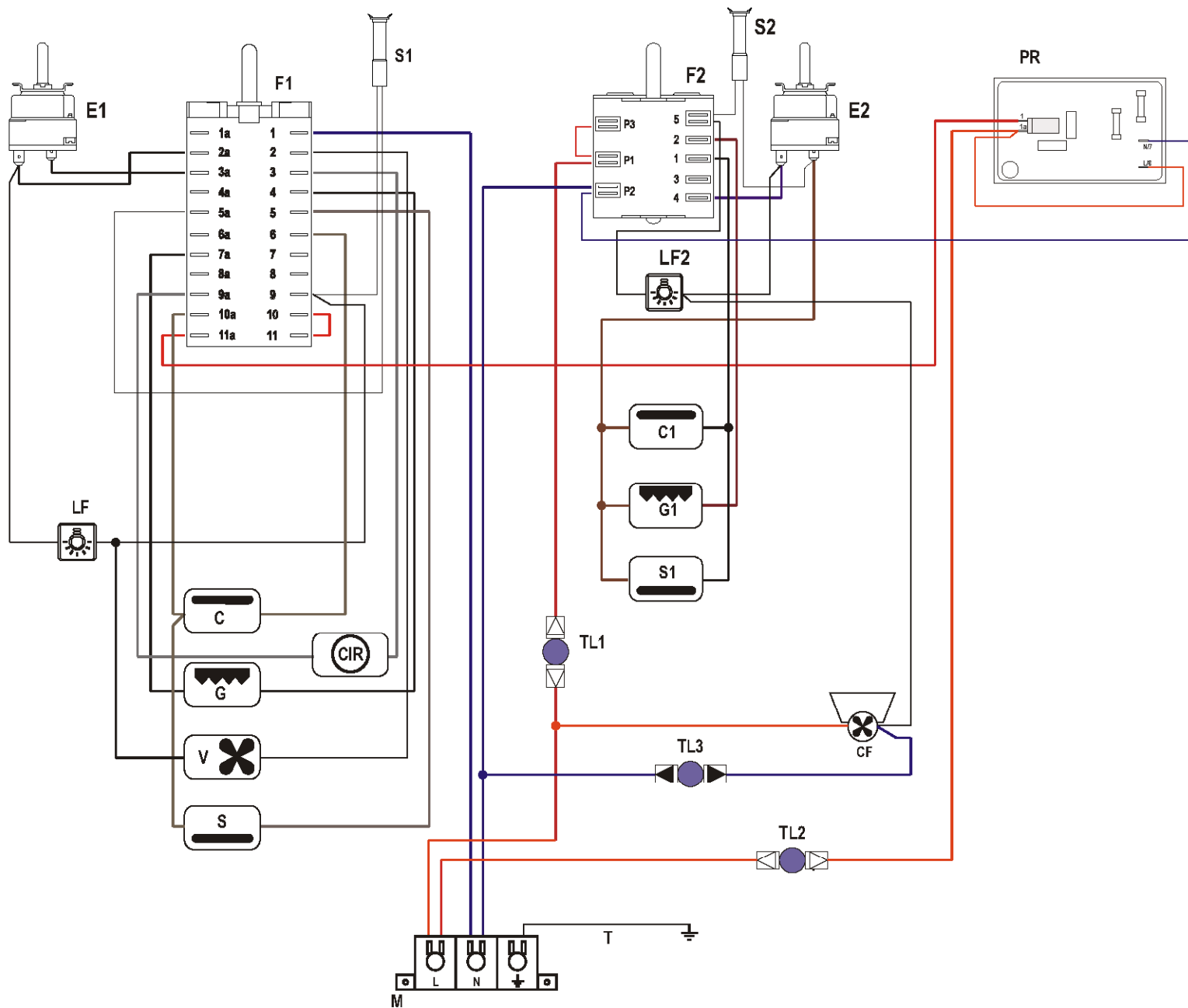

ELECTRIC DIAGRAM KEY

- TOP OVEN**
 F2 Oven switch
 E2 Oven thermostat
 S2 Thermostat pilot lamp
 LF2 Oven lamp
 C1 Top element
 G1 Grill element
 S1 Bottom element
 TL1 Thermal overload
- BOTTOM OVEN**
 F1 Oven switch
 E1 Oven thermostat
 S1 Thermostat pilot lamp
 PR Oven programmer 1P
 LF Oven lamp
 C Top element
 G Grill element
 V Fan
 S Bottom element
 CIR Circular element
 TL2 Thermal overload
- CF Cooling fan
 TL3 Thermal overload
 M Terminal block
 T Earth connection



C308SS

Caple Double Multi Function Oven
 Stainless Steel

TYPE 1- VALID FROM 1ST PRODUCTION TO AUGUST 2004 (PRODUCTION DATE)111

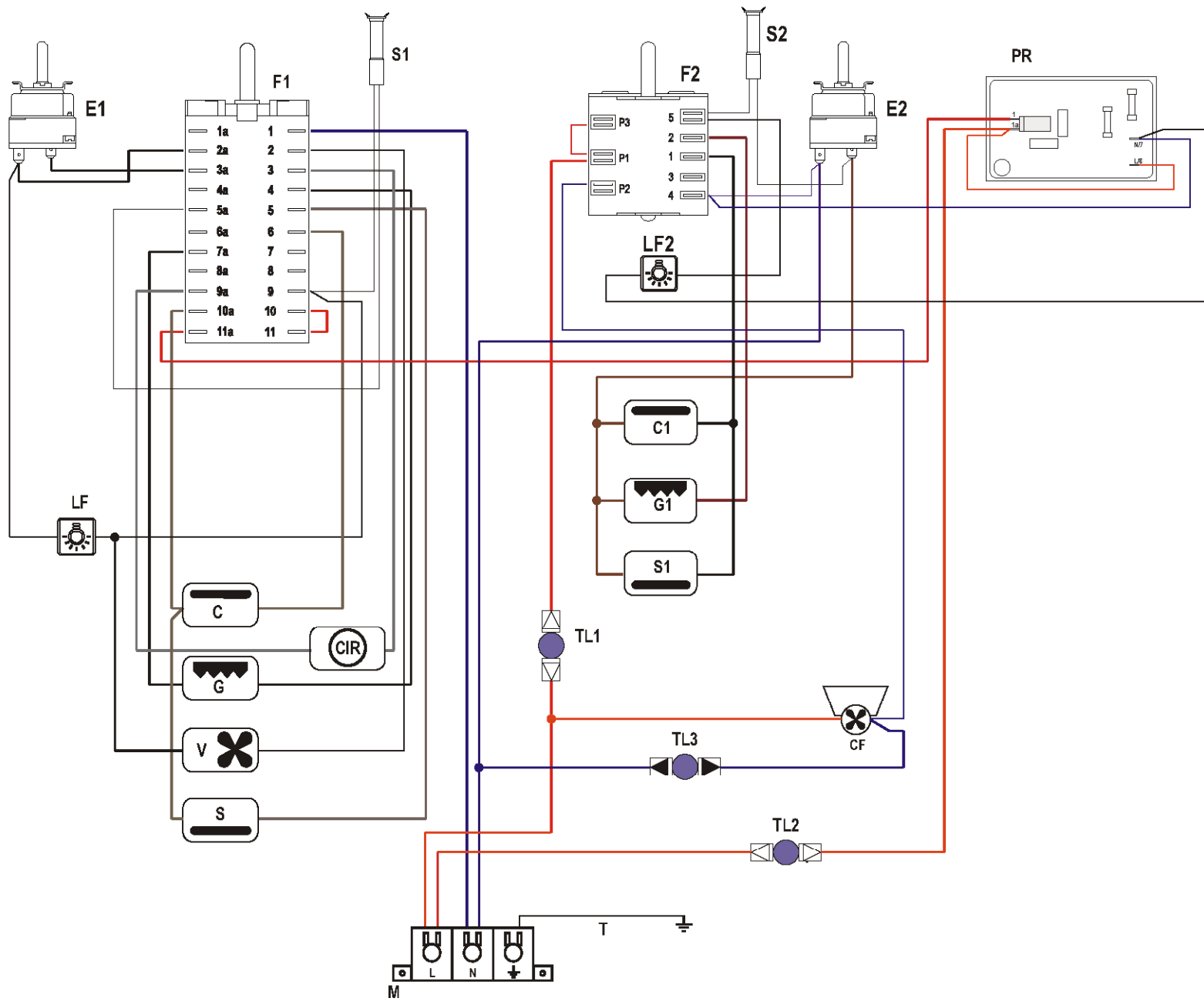

ELECTRIC DIAGRAM KEY

- TOP OVEN**
 F2 Oven switch
 E2 Oven thermostat
 S2 Thermostat pilot lamp
 LF2 Oven lamp
 C1 Top element
 G1 Grill element
 S1 Bottom element
 TL1 Thermal overload

- BOTTOM OVEN**
 F1 Oven switch
 E1 Oven thermostat
 S1 Thermostat pilot lamp
 PR Oven programmer 1P
 LF Oven lamp
 C Top element
 G Grill element
 V Fan
 S Bottom element
 CIR Circular element
 TL2 Thermal overload

- CF Cooling fan
 TL3 Thermal overload
 M Terminal block
 T Earth connection



C308SS

Caple Double Multi Function Oven
 Stainless Steel

TYPE 2 - VALID TILL SEPTEMBER 2004