



C302W

Caple Double D.L Fan Oven White



TECHNICAL INFORMATION

C 302 W

FUM0CP007W

tav. 1

cat. 18.F2924

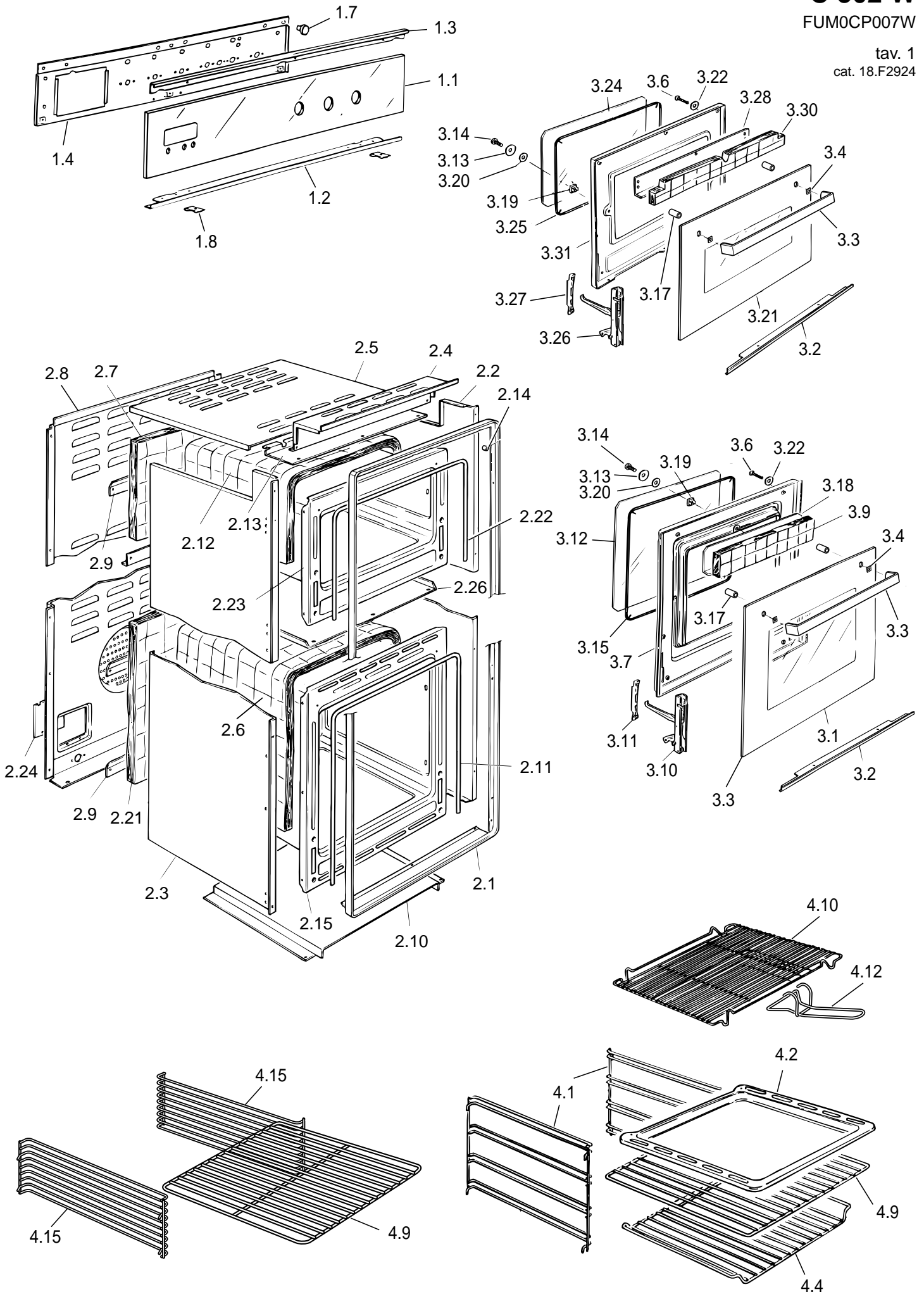

REF.	CODE	DESCRIPTION
1.1	0312255	Glass fascia panel
1.2	083093035	Lower retainer trim
1.3	083188035	Upper retainer trim
1.4	35MF70204	Interior control panel
1.7	040011	Glass spacer
1.8	213007	Clip
2.1	083225035	Trim surround
2.2	411UM02	Right side panel
2.3	411UM03	Left side panel
2.4	411F711	Control panel shelter
2.5	411UM06	Upper shelter
2.6	030092.1	Bottom oven insulation
2.7	030065	Bottom oven rear insulation
2.8	411UM01.1	Rear panel
2.9	4216003Z	Insulation cross-piece
2.10	411F706	Bottom panel
2.11	053039	Bottom oven seal
2.12	030066.1	Top oven insulation
2.13	421UM01Z	Lower switch shelter
2.14	085019	Spacer
2.15	450UM1EV11	Bottom oven cube
2.21	030028	Top oven rear insulation
2.22	053052	Top oven seal
2.23	450UM1ES11	Top oven cube
2.24	51BUM01	Shield
2.26	411UM04	Shelter
3.1	0311838	Outer glass
3.2	083186035	Lower retainer trim
3.3	037228035	Handle
3.4	103734035	Plaque
3.6	001108	Screw
3.7	373FF704K	Bottom oven door skin
3.9	030057	Bottom oven door insulation
3.10	063035	Bottom oven hinge (male)
3.11	063025	Bottom oven hinge (female)
3.12	0311000.1T	Bottom oven inner glass
3.13	103205	Inner glass washer
3.14	001214	Screw
3.15	053084	Bottom oven glass seal
3.17	085071	Sleeve
3.18	411F729	Bottom oven insulation support
3.19	214021	Nut with clips
3.20	003035	Silicone washer
3.21	0312256	Top oven outer glass
3.22	003030	Washer
3.24	0311086.1T	Top oven inner glass
3.25	053086	Top oven glass seal
3.26	063065	Top oven hinge (male)
3.27	063066	Top oven hinge (female)
3.28	411UM05	Top oven insulation support
3.30	030064	Top oven door insulation
3.31	373FUM02K	Top oven door skin
4.1	217291	Shelf support
4.2	48B6101K	Oven tray
4.4	217271	Wire shelf
4.9	217270.1	Wire shelf
4.10	217397	Grill-pan grid
4.12	037144	Grill-pan grid handle
4.15	217503	Shelf support

C 302 W

FUM0CP007W

tav. 2
cat. 18.F2924

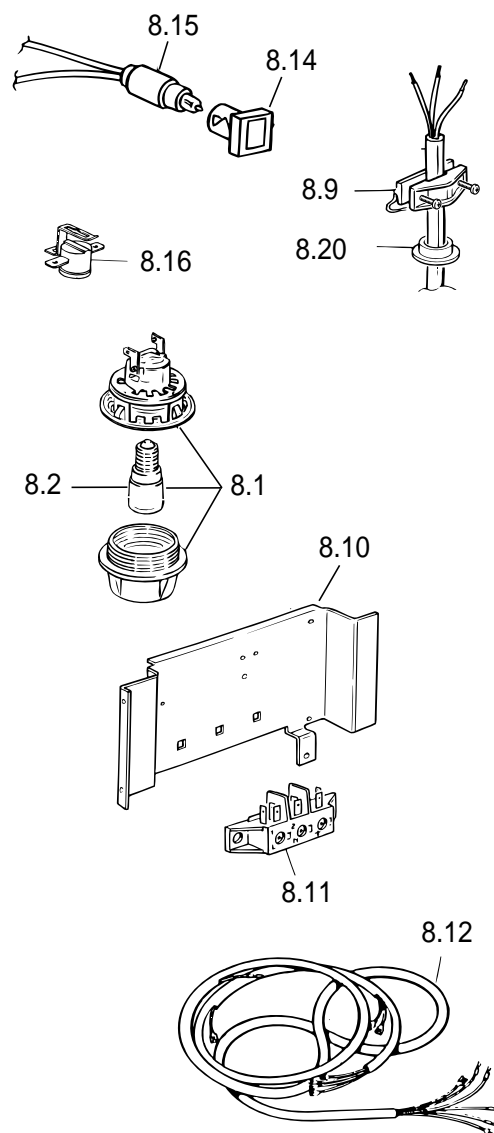
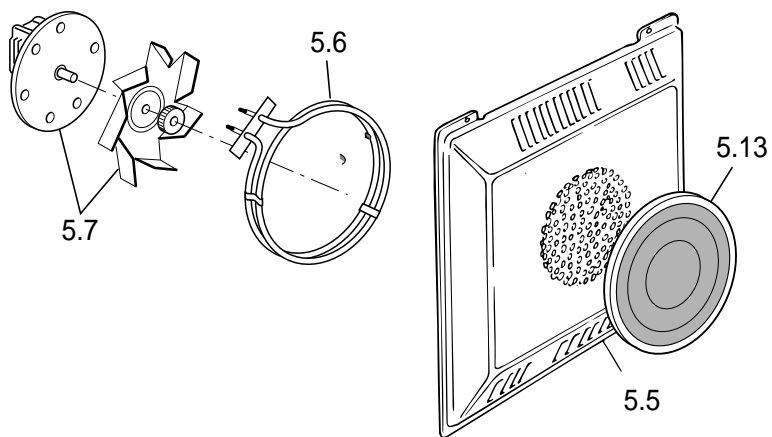
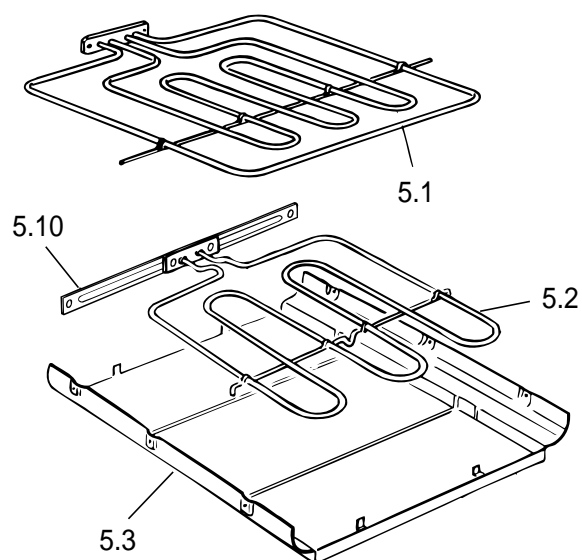
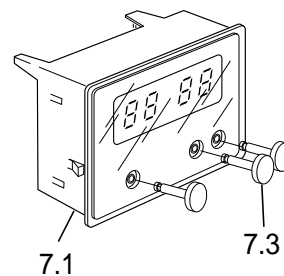
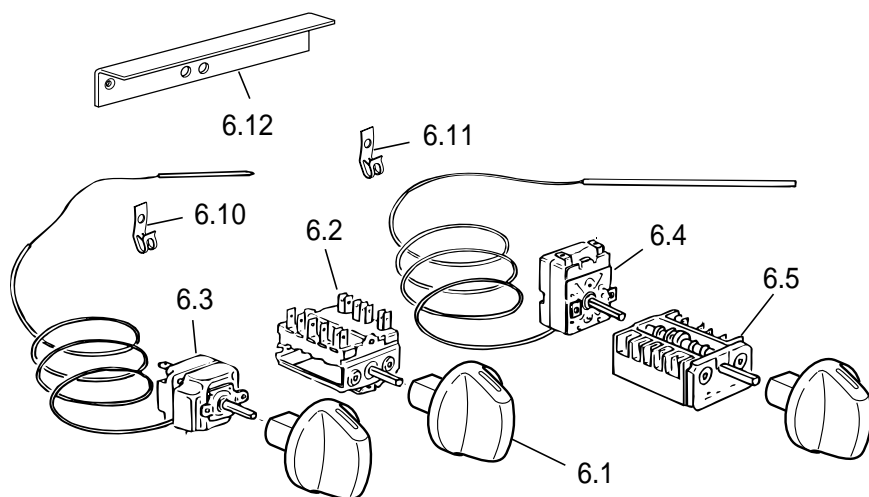

REF.	CODE	DESCRIPTION
5.1	062072004	Top grill element - 230 V
5.2	062058004A	Top oven bottom element - 230 V
5.3	421F701Z	Element shelter
5.5	47AN601K	Fan diffuser
5.6	062057004	Fan element - 230 V
5.7	079008001F	Fan motor - 220/240 V
5.10	094207	Bottom element fixing bar
5.13	103085	Filter
6.1	218G006338	Switch knob
6.2	050040.1	Switch
6.3	066072	Thermostat
6.4	066078	Thermostat
6.5	050045	Switch
6.10	213023	Clip
6.11	213015	Clip
6.12	094289	Bulb thermostat protection
7.1	074055	Electronic programmer
7.3	103271035	Button (White)
8.1	072004	Lamp holder
8.2	073013001	Lamp
8.9	052008	Wire fastener
8.10	094162	Terminal bracket
8.11	051038	Terminal block
8.12	1131282	Wiring
8.14	073030	Control lamp cover (Red)
8.15	073031	Control lamp L=200
8.16	066057	Cut-off thermostat 140°
=	066073	Cut-off thermostat 150°
8.20	052007	Anti-shock
-	1102115	Instruction booklet

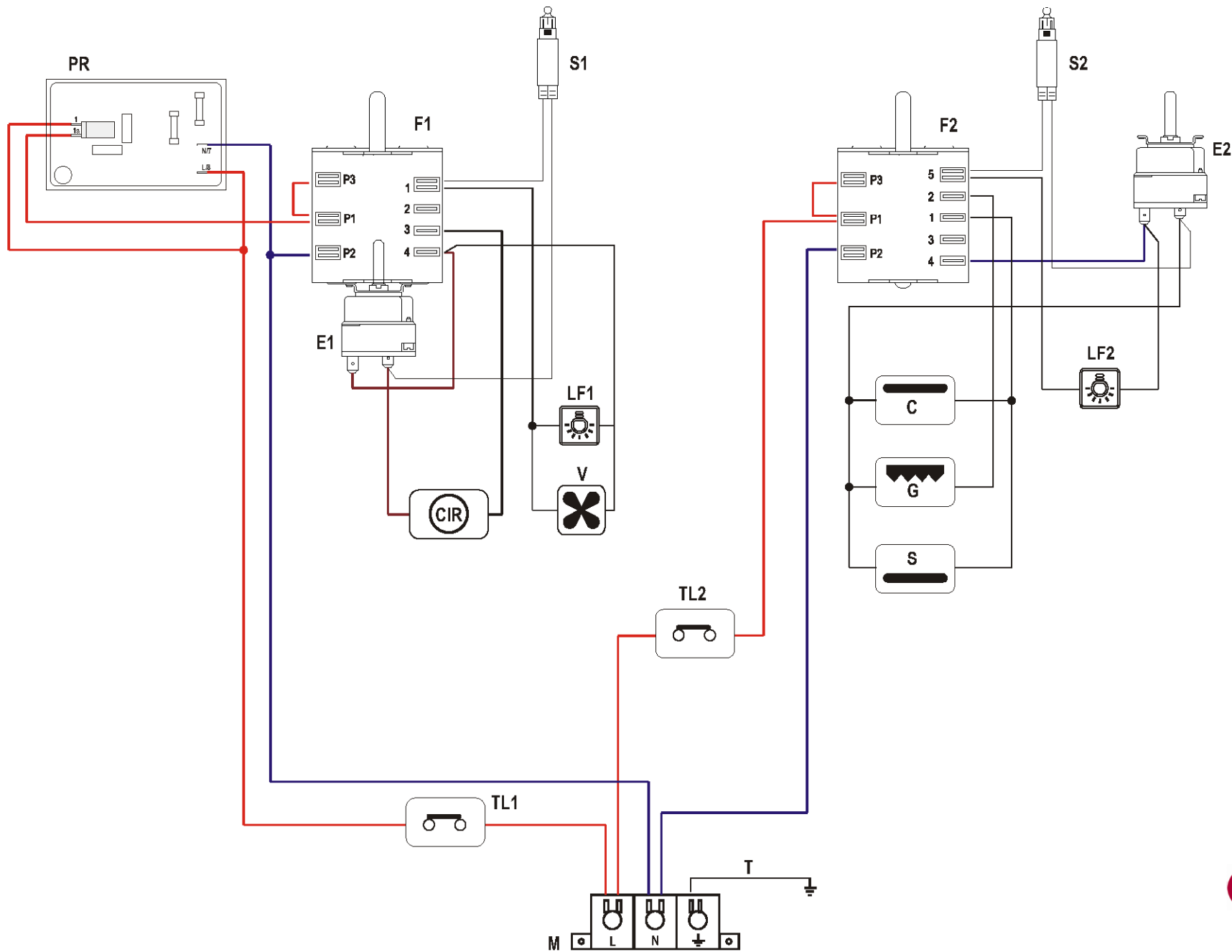

ELECTRIC DIAGRAM KEY

TOP OVEN

- F2 Oven switch
- E2 Oven thermostat
- LF2 Oven lamp
- S2 Thermostat pilot lamp
- C Top element
- G Grill element
- S Bottom element
- TL2 Thermal overload

BOTTOM OVEN

- F1 Oven switch
- E1 Oven thermostat
- LF1 Oven lamp
- PR Programmer
- S1 Thermostat pilot lamp
- CIR Circular element
- V Fan
- TL1 Thermal overload
- M Terminal block
- T Earth connection



C302W

Caple Double D.L Fan Oven White