

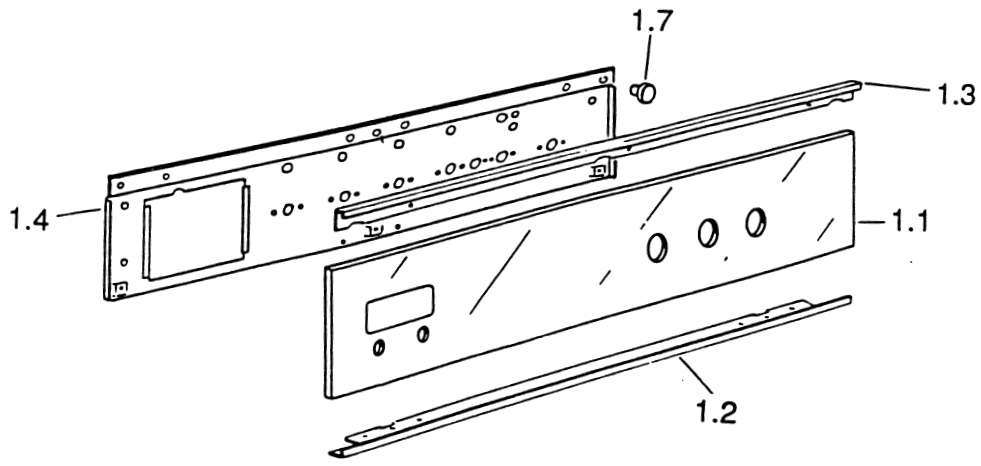

C300F/B

Caple Double D.L. Fan Oven Brown

TECHNICAL INFORMATION



3/1.F

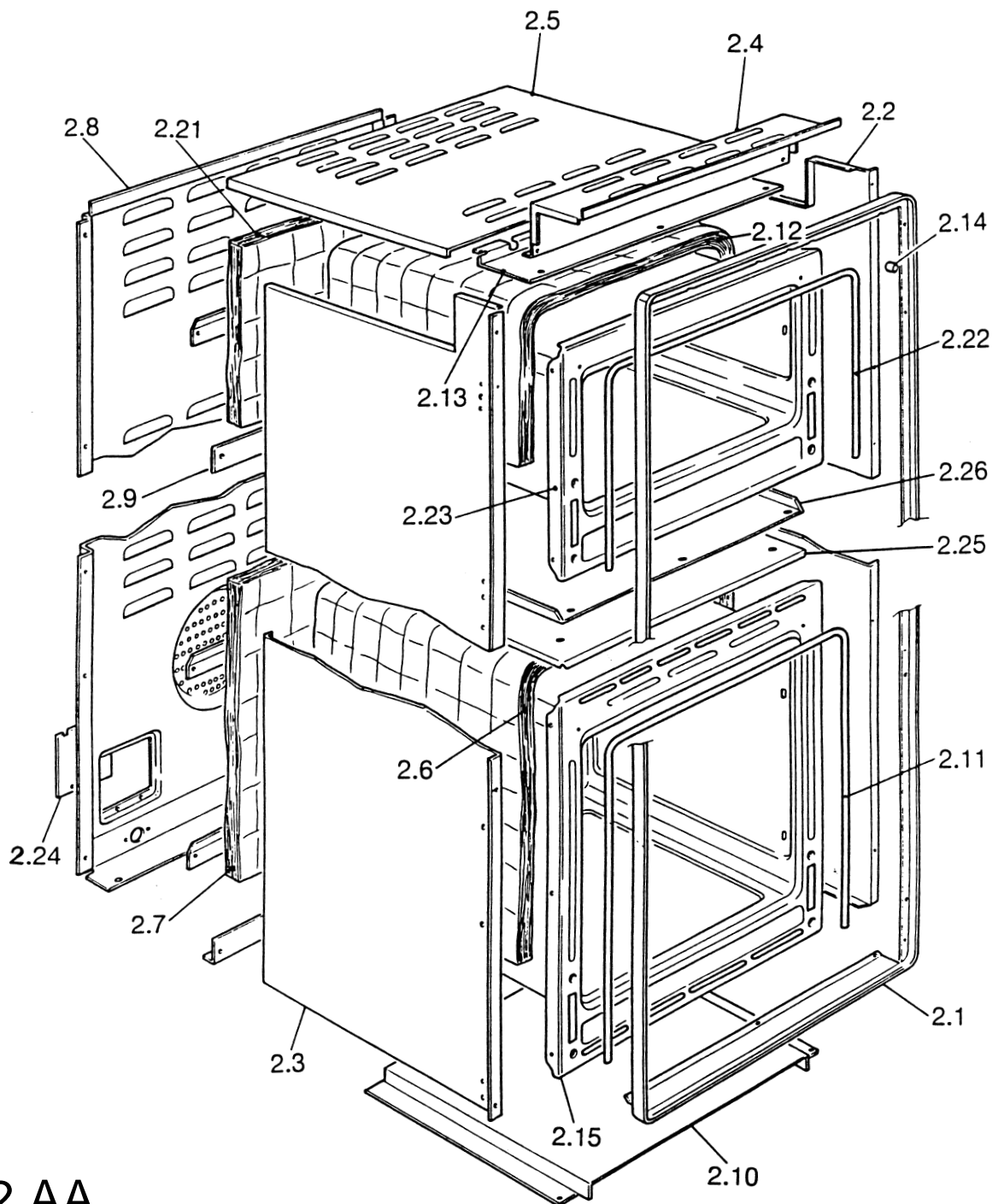

3/2.AA

CONTROL PANEL AND BODY
OVENS: mod. C 300F/W, C 300F/B

Ref. Table: 3/1.F

<u>REF.</u>	<u>CODE</u>	<u>DESCRIPTION</u>
1.1	0311422	Glass fascia panel - Mod. W
=	0311423	Glass fascia panel - Mod. B
1.2	083093021	Lower retainer trim - (Brown)
=	083093035	Lower retainer trim - (White)
1.3	083188021	Upper retainer trim - (Brown)
=	083188035	Upper retainer trim - (White)
1.4	35MF70203	Interior control panel
1.7	040011	Glass spacer

Ref. Table: 3/2.AA

<u>REF.</u>	<u>CODE</u>	<u>DESCRIPTION</u>
2.1	083225035	Trim surround (White)
=	083225021	Trim surround (Brown)
2.2	411UM02	Right side panel
2.3	411UM03	Left side panel
2.4	411F711	Control panel shelter
2.5	411UM06	Upper shelter
2.6	030092.1	Bottom oven insulation
2.7	030028	Bottom oven rear insulation
2.8	411UM01	Rear panel
2.9	4216003Z	Insulation cross-piece
2.10	411F706	Bottom panel
2.11	053039	Bottom oven seal
2.12	030066	Top oven insulation
2.13	421UM01Z	Lower switch shelter
2.14	085019	Spacer
2.15	450UM1EV11	Bottom oven cube
2.21	030065	Top oven rear insulation
2.22	053052	Top oven seal
2.23	450UM1ES11	Top oven cube
2.24	51BUM01	Shield
2.25	421FG01Z	Top oven element shelter
2.26	411UM04	Shelter

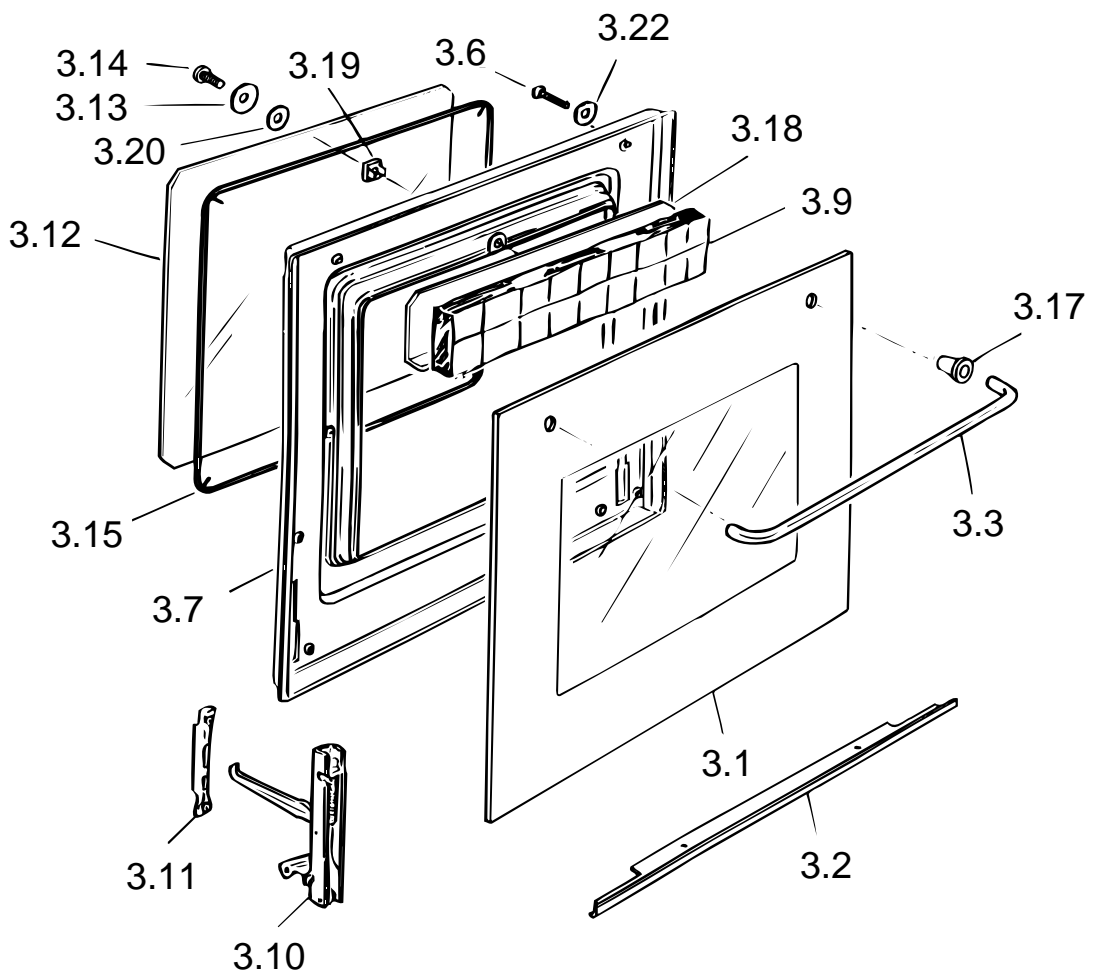
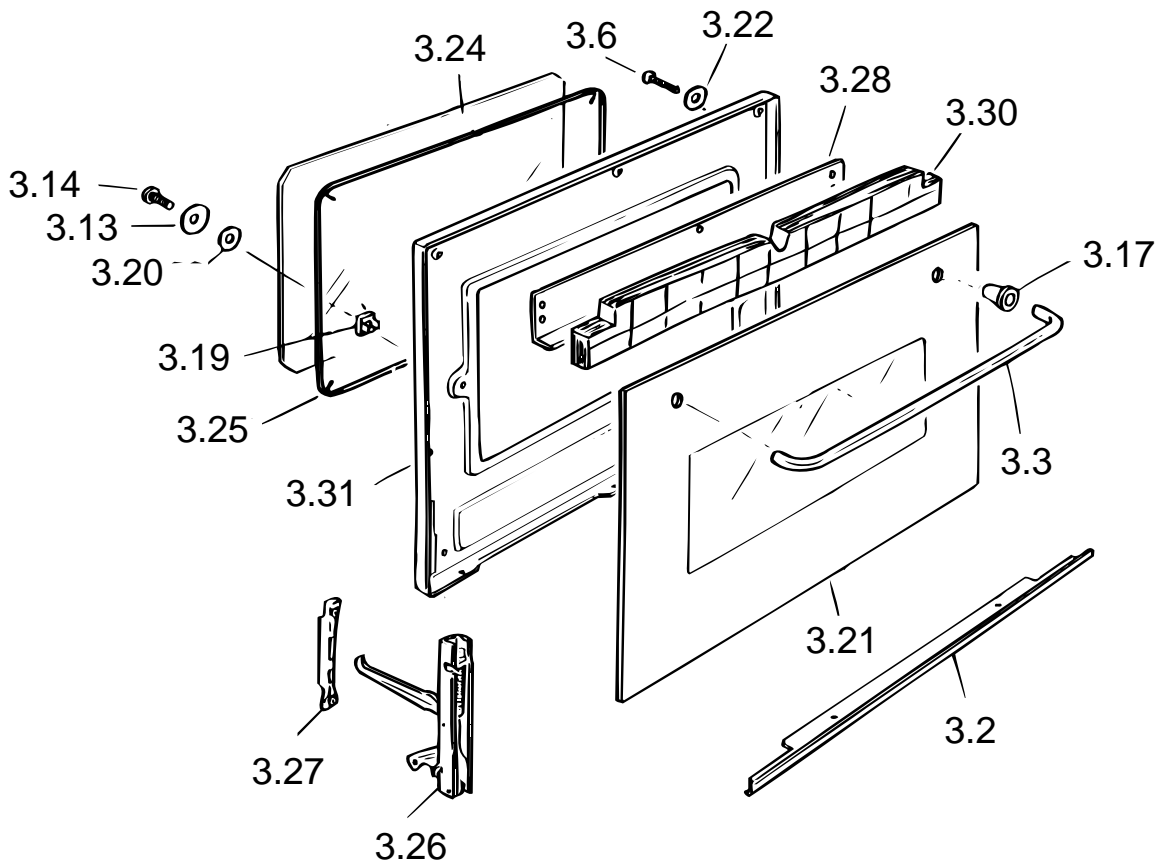

3/3.SB

OVEN DOOR

OVENS: mod. C 300F/W, C 300F/B

Ref. Table: 3/3.SB

<u>REF.</u>	<u>CODE</u>	<u>DESCRIPTION</u>
3.1	0311360	Bottom oven outer glass - Mod. W
=	0311362	Bottom oven outer glass - Mod. B
3.2	083186035	Lower retainer trim (White)
=	083186021	Lower retainer trim (Brown)
3.3	037128035	Handle (White)
=	037128021	Handle (Brown)
3.6	001105	Screw
3.7	373FF704K	Bottom oven door skin
3.9	030057	Bottom oven door insulation
3.10	063053	Bottom oven hinge (male)
3.11	063025	Bottom oven hinge (female)
3.12	0311000.1T	Bottom oven inner glass
3.13	103205	Inner glass washer
3.14	001024	Screw
3.15	053084	Bottom oven glass seal
3.17	085028021	Sleeve - Mod. W
=	085028035	Sleeve - Mod. B
3.18	411F729	Bottom oven insulation support
3.19	214021	Nut with clips
3.20	003035	Silicone washer
3.21	0311361	Top oven outer glass - Mod. W
=	0311363	Top oven outer glass - Mod. B
3.22	003041	Washer
3.24	0311086.1T	Top oven inner glass
3.25	053086	Top oven glass seal
3.26	063065	Top oven hinge (male)
3.27	063066	Top oven hinge (female)
3.28	411UM05	Top oven insulation support
3.30	030064	Top oven door insulation
3.31	373FUM02K	Top oven door skin

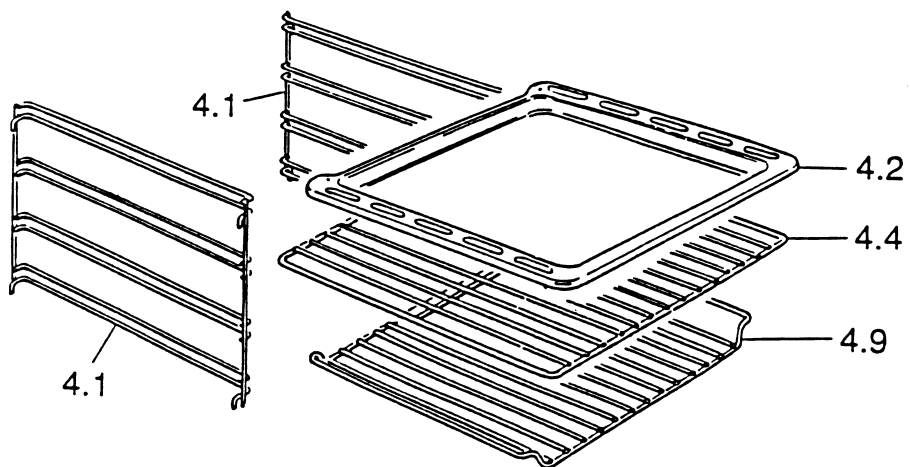
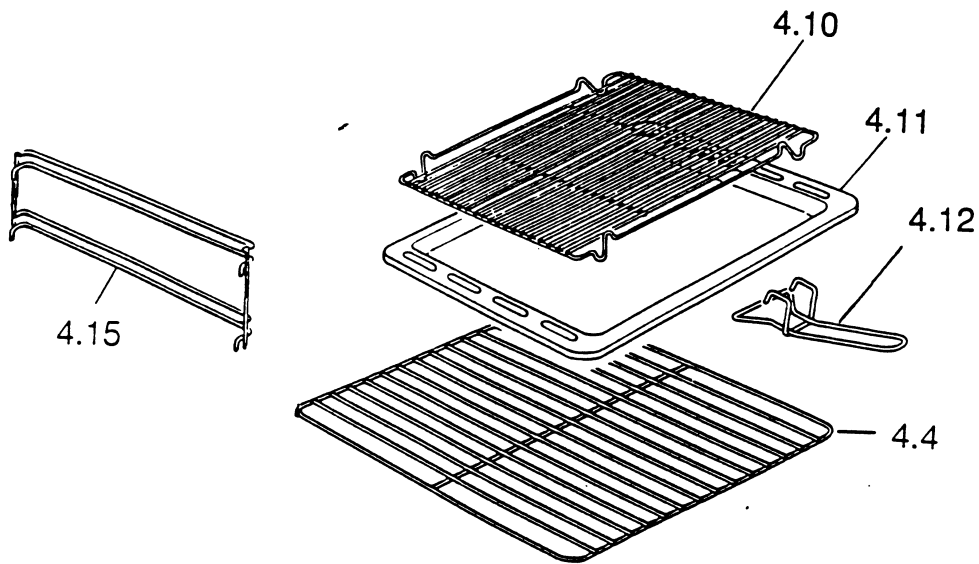

3/4.B

OVEN EQUIPMENT**OVENS: mod. C 300F/W, C 300F/B**

Ref. Table: 3/4.B

<u>REF.</u>	<u>CODE</u>	<u>DESCRIPTION</u>
4.1	217291	Shelf support
4.2	48B6101K	Oven tray
4.4	217270.1	Wire shelf
4.9	217271	Wire shelf
4.10	217385	Grill-pan grid
4.11	48B5102K	Grill-pan
4.12	037144	Grill-pan grid handle
4.15	217367	Shelf support

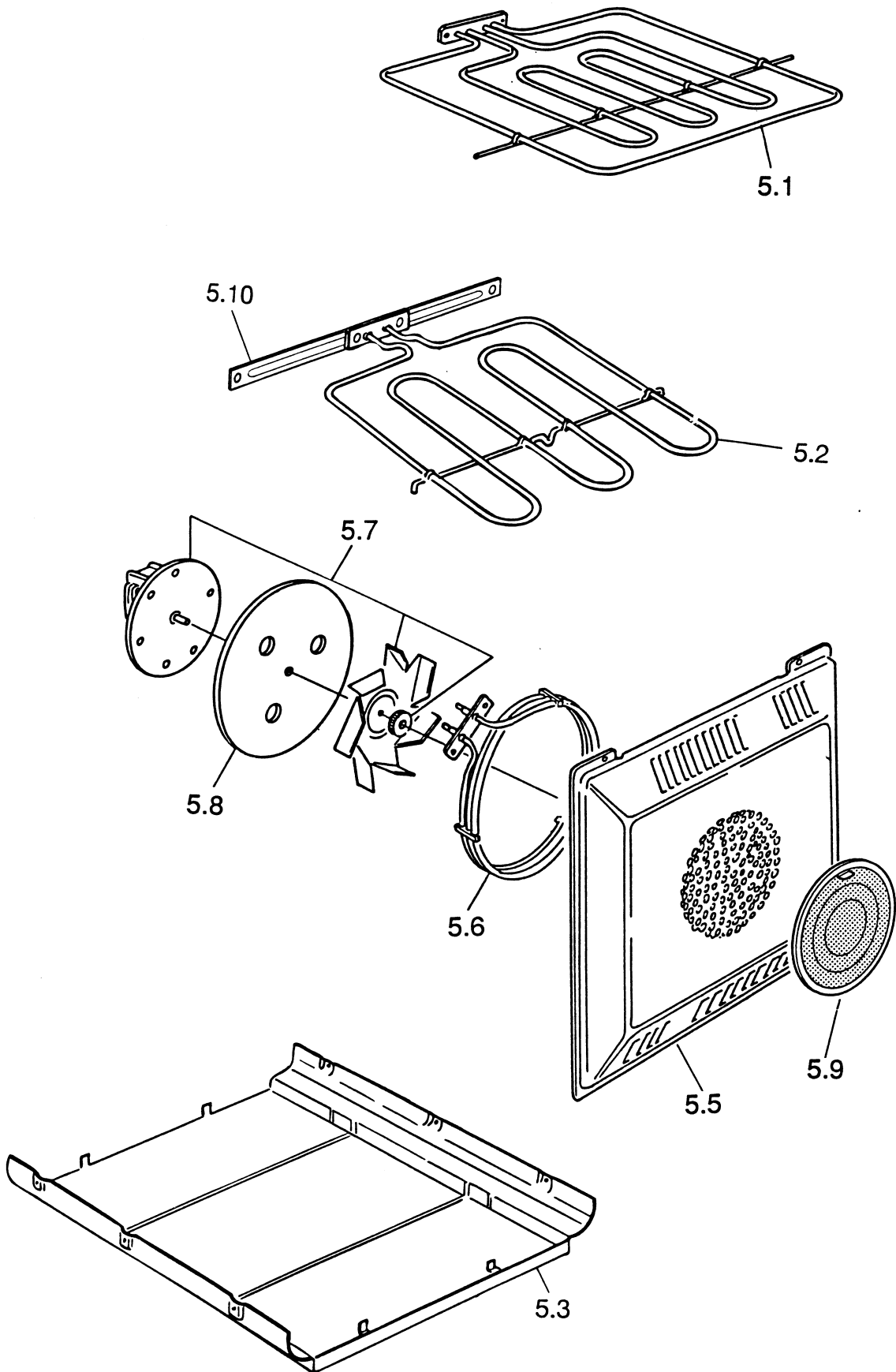

3/5.A

CONVECTION AND FAN OVENS
OVENS: mod. C 300F/W, C 300F/B

Ref. Table: 3/5.A

<u>REF.</u>	<u>CODE</u>	<u>DESCRIPTION</u>
5.1	062072004	Top + grill element - 230 V
5.2	062058004A	Bottom element - 230 V
5.3	421F701Z	Element shelter
5.5	47AN601K	Fan diffuser
5.6	062057004	Fan element - 230 V
5.7	079008001F	Fan motor - 220/240 V
5.8	039036	Fan motor insulation
5.9	103085	Filter
5.10	094207	Bottom element fixing bar

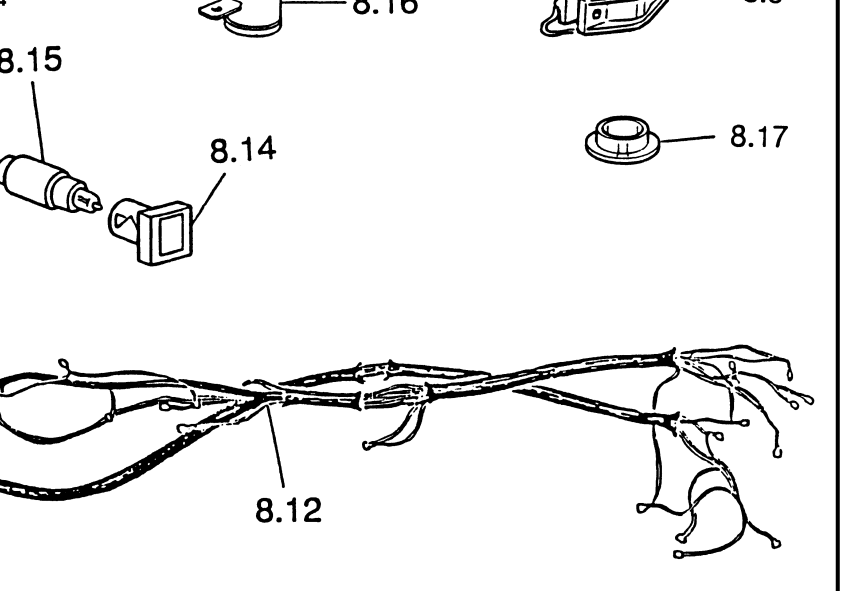
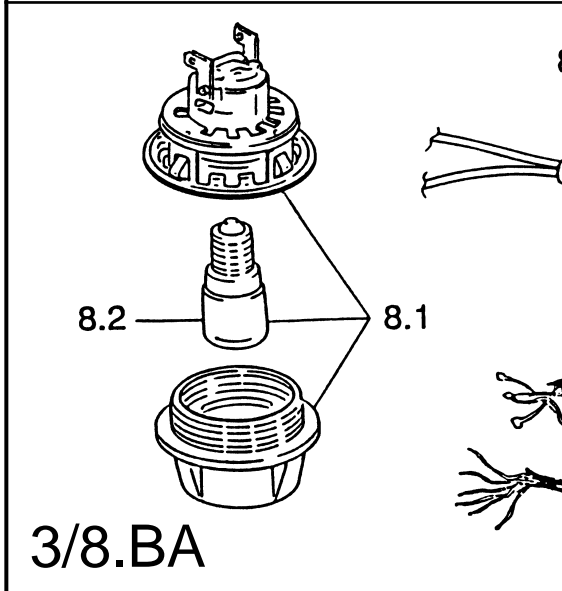
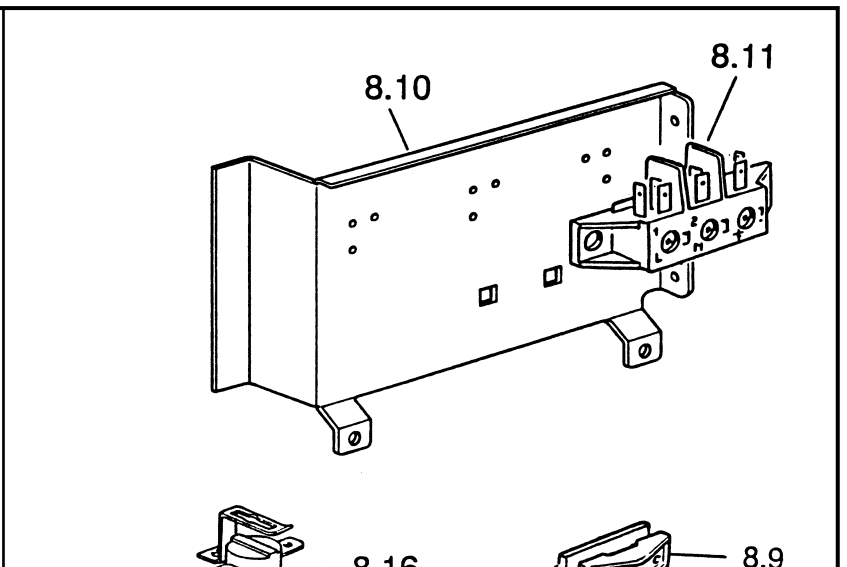
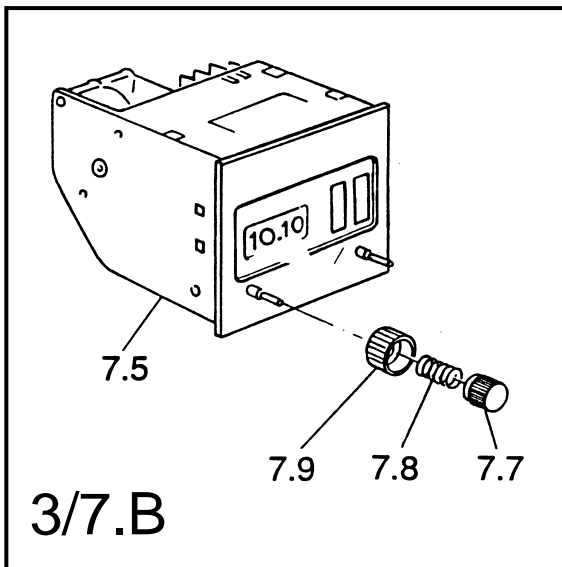
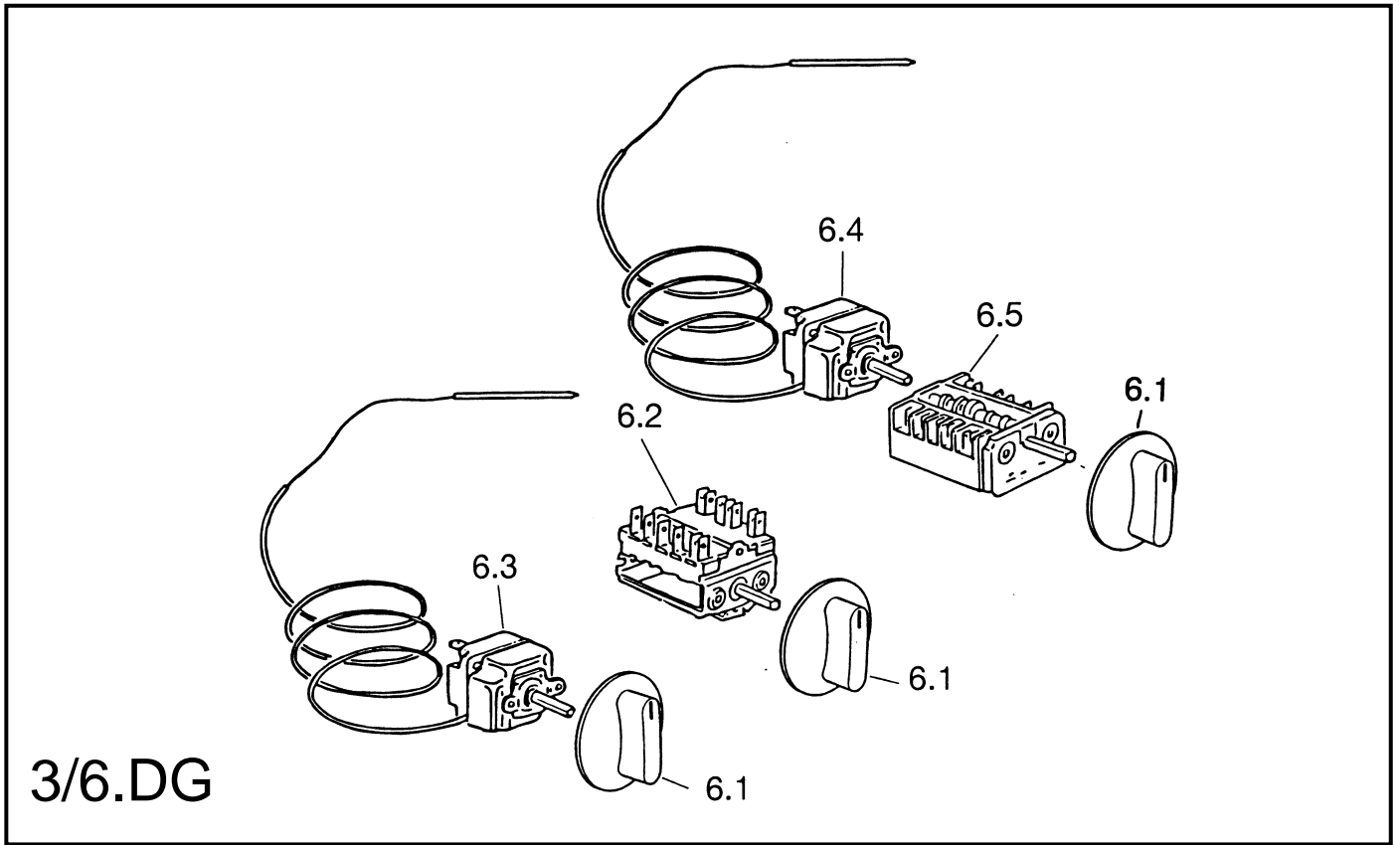

SWITCHES & THERMOSTATS

OVENS: mod. C 300F/W, C 300F/B

Ref. Table: 3/6.DG

<u>REF.</u>	<u>CODE</u>	<u>DESCRIPTION</u>
6.1	218A003102	Control knob (White)
=	218P004102	Control knob (Brown)
6.2	050040.1	Switch
6.3	066072	Thermostat
6.4	066078	Thermostat
6.5	050045	Switch

ELECTRIC PROGRAMMER

OVENS: mod. C 300F/W, C 300F/B

Ref. Table: 3/7.B

<u>REF.</u>	<u>CODE</u>	<u>DESCRIPTION</u>
7.5	074013	Electric programmer
7.7	2180003094	Programmer knob (White)
=	2180001094	Programmer knob (Brown)
7.8	035025	Knob spring
7.9	103076003	Knob ring (White)
=	103076001	Knob ring (Brown)

ELECTRICAL EQUIPMENT

OVENS: mod. C 300F/W, C 300F/B

Ref. Table: 3/8.BA

<u>REF.</u>	<u>CODE</u>	<u>DESCRIPTION</u>
8.1	072004	Lamp holder
8.2	073013001	Lamp
8.9	052008	Wire fastener
8.10	094162	Terminal bracket
8.11	051038	Terminal block
8.12	113739	Wiring
8.14	073030	Control lamp cover (Red)
8.15	073031	Control lamp (rectangular)
8.16	066057	Cut-off thermostat
8.17	052007	Anti-shock
—	110922	Instruction booklet

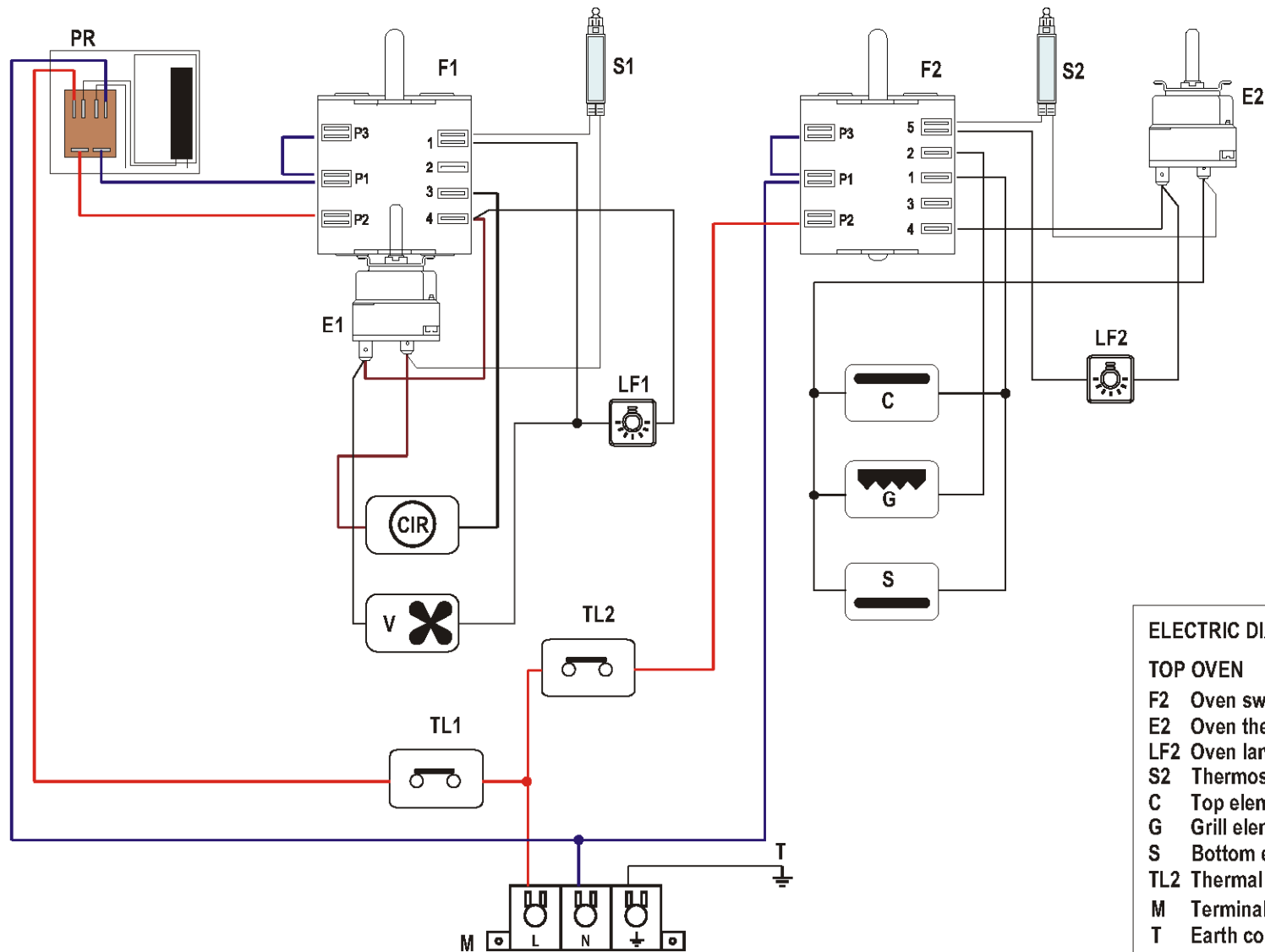

Top oven switch diagram F2

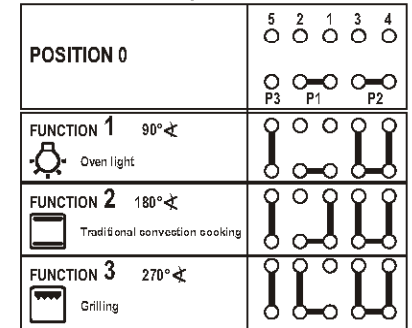

Bottom main oven diagram F1

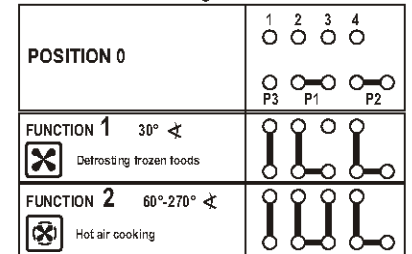

ELECTRIC DIAGRAM KEY

TOP OVEN

- F2 Oven switch
- E2 Oven thermostat
- LF2 Oven lamp
- S2 Thermostat pilot lamp
- C Top element
- G Grill element
- S Bottom element
- TL2 Thermal overload
- M Terminal block
- T Earth connection

BOTTOM OVEN

- F1 Oven switch
- E1 Oven thermostat
- LF1 Oven lamp
- PR Programmer
- S1 Thermostat pilot lamp
- CIR Circular element
- V Fan
- TL1 Thermal overload



C300F/B

Caple Double D.L. Fan Oven Brown